



# The Advanced Virgo monolithic fused silica suspension



P. Puppo<sup>3</sup> for the monolithic suspension team  
*INFN Roma*





# Monolithic suspensions of the Advanced Virgo Mirror

- Double pendulum system;
- 40 kg mirror suspended with fused silica fibers;
- new wire clamping with the upper stage, silica-steel interface at the level of the upper stage;
- new ears and wire upper and lower T-clamps;

## Upper Clamps

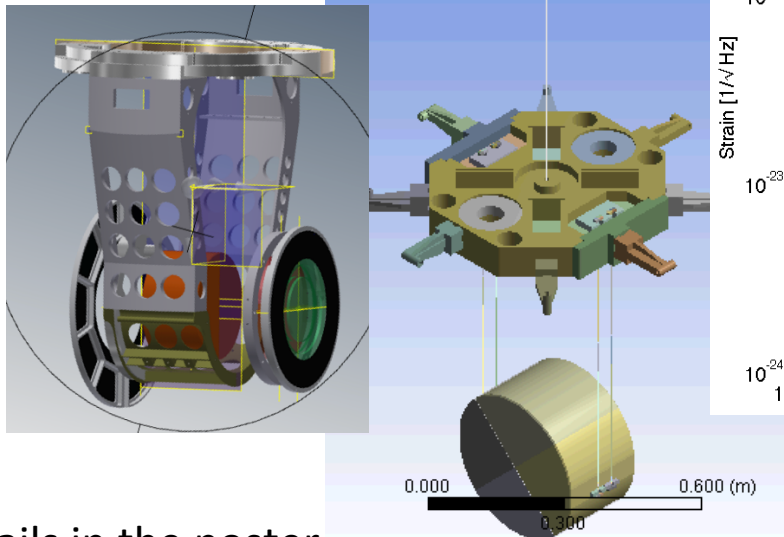
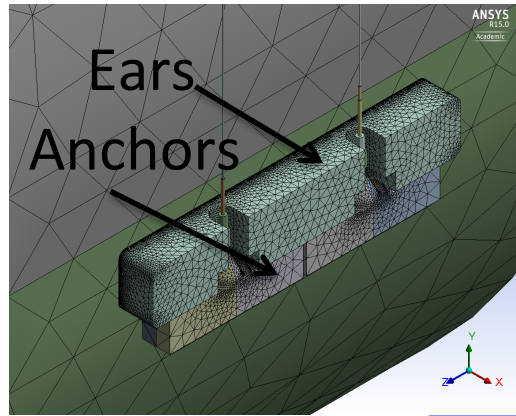
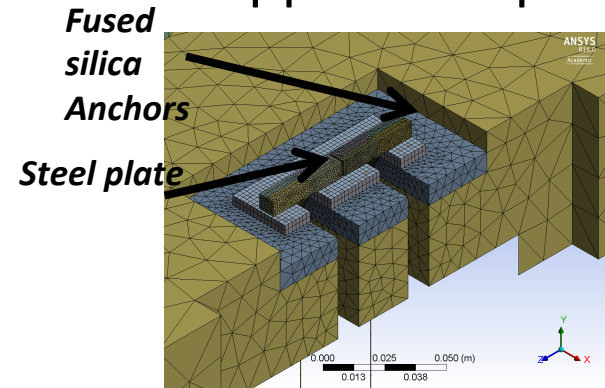

Details in the poster

## Thermal Noise Calculation with FEM

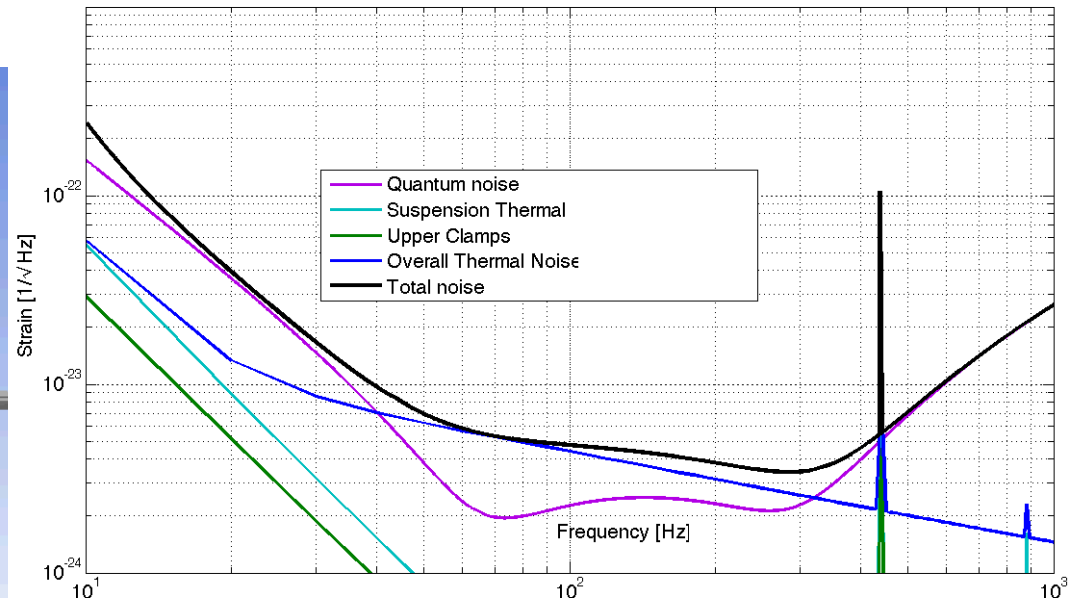

The mirror and suspension thermal noise calculated with FEM (blue) is compared with the Advanced Virgo sensitivity curve (black).