

*Transversity 2014 Closing Remarks:
Moving Forward in the Era of
Quantitative QCD*

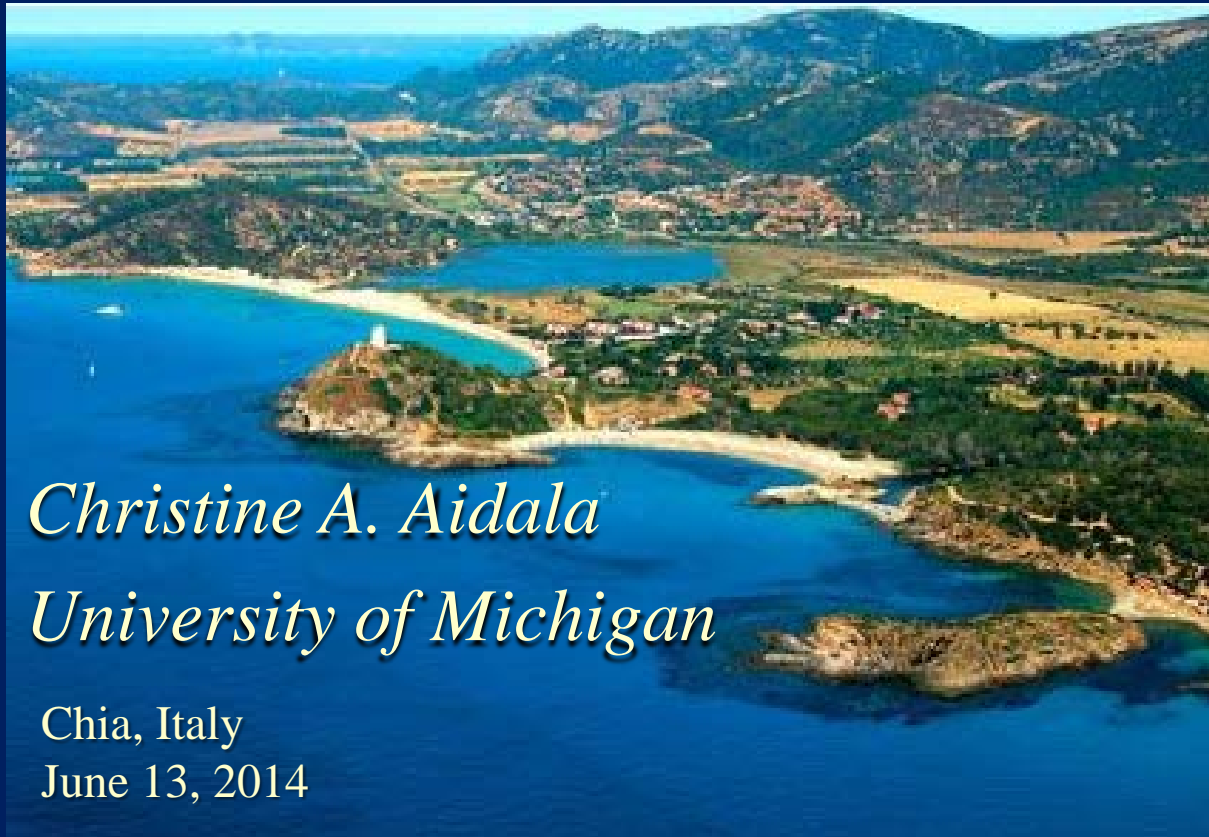

*Christine A. Aidala
University of Michigan*

Chia, Italy
June 13, 2014



QCD: How far have we come?

“You can’t anticipate all the things nature will do with that Lagrangian.”

– L. Bland



- Three-decade period after initial birth of QCD dedicated to “discovery and development”
→ Symbolic closure: Nobel prize 2004 - Gross, Politzer, Wilczek for asymptotic freedom

*Now early years of
second phase:
quantitative QCD!*



Advancing into the era of quantitative QCD: Theory has been forging ahead!

- In perturbative QCD, since 1990s starting to consider detailed internal QCD dynamics that parts with traditional parton model ways of looking at hadrons—and perform phenomenological calculations using these new ideas/tools!
E.g.:
 - Various *resummation* techniques
 - *Non-linear* evolution at small momentum fractions
 - *Non-collinearity* of partons with parent hadron
 - *Spatial* distributions of partons in hadrons
- Non-perturbative methods:
 - Lattice QCD less and less limited by computing resources—since 2010 starting to perform calculations at the physical pion mass (after 36 years!). Plus recent new ideas on how to calculate previously intractable quantities.
 - AdS/CFT “gauge-string duality” an exciting recent development as first fundamentally new handle to try to tackle QCD in decades!



Advancing into the era of quantitative QCD: Theory has been forging ahead!

- In perturbative QCD, since 1990s started to explore QCD dynamics that parts with traditional hadrons—and perform phenomenological ideas/tools!

E.g.:

- Various *resummation* techniques
 - *Non-linear* evolution at small momenta
 - *Non-collinearity* of partons with partons
 - *Spatial* distributions of partons in hadrons
- Non-perturbative methods:
 - Lattice QCD less and less limited by computing resources—since 2010 starting to perform calculations at the physical pion mass (after 36 years!). Plus recent new ideas on how to calculate previously intractable quantities.
 - AdS/CFT “gauge-string duality” an exciting recent development as first fundamentally new handle to try to tackle QCD in decades!

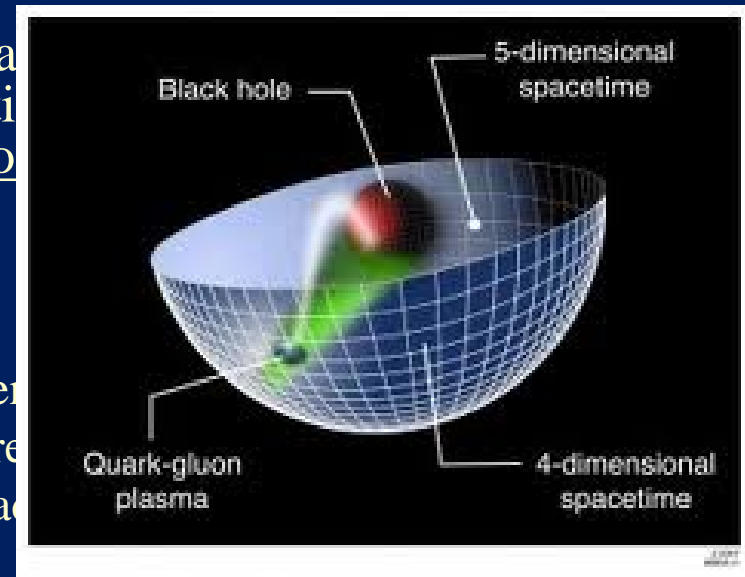

Effective field theories

- QCD exhibits different behavior at different scales—effective field theories are useful approximations within these different regimes
 - Color Glass Condensate – high energies, high densities
 - Soft-Collinear Effective Theory – new insights into performing complicated perturbative calculations very quickly
 - Heavy Quark Effective Theory, Non-Relativistic QCD, . . .
 - Many effective theories for nonperturbative QCD – chiral symmetry breaking, . . .



Example: Threshold resummation to extend pQCD to lower energies

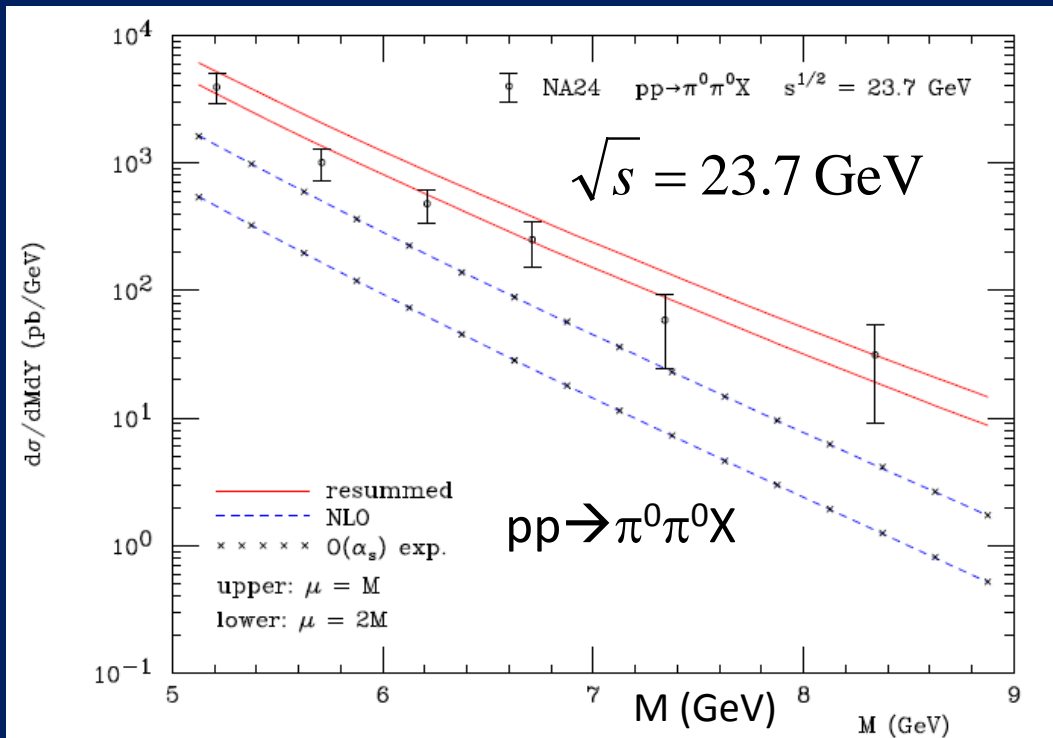

For observables with two different scales, sum logs of their ratio to all orders

Almeida, Sterman, Vogelsang PRD80, 074016 (2009)



Example: Phenomenological applications of a non-linear gluon saturation regime at low x

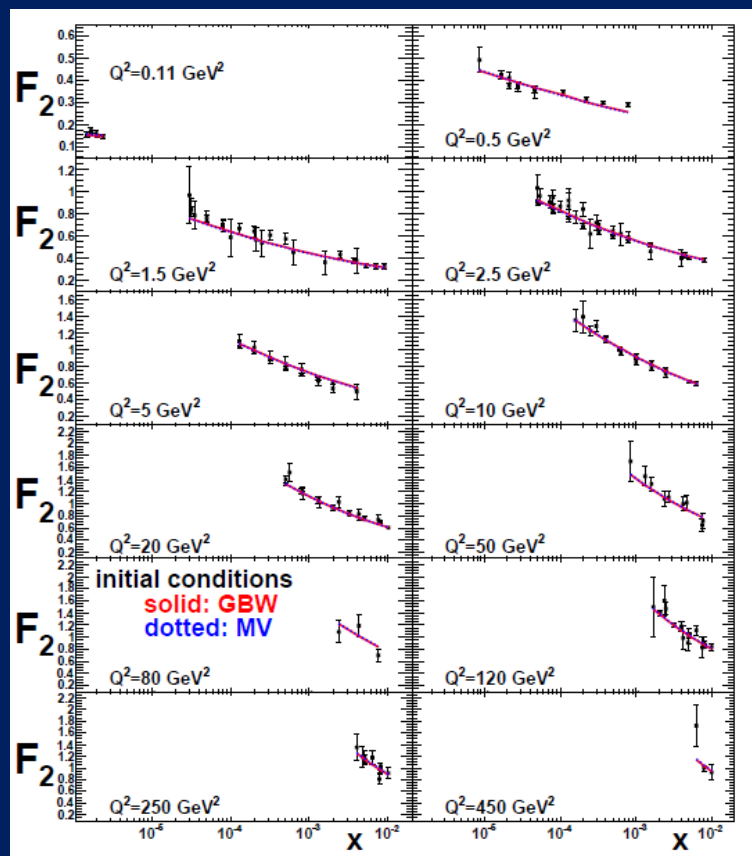

Fits to proton structure function data at low parton momentum fraction x .

Non-linear QCD meets data: A global analysis of lepton-proton scattering with running coupling BK evolution

Phys. Rev. D80, 034031 (2009)

Javier L. Albacete¹, Néstor Armesto², José Guilherme Milhano³ and Carlos A. Salgado²

Basic framework for non-linear QCD, in which gluon densities are so high that there's a non-negligible probability for two gluons to combine, developed ~1997-2001. But had to wait until “running coupling BK evolution” figured out in 2007 to compare directly to data!

Example: Dropping the simplifying assumption of collinearity

Mulders & Tangerman, NPB 461 (1996) 197

Distribution Functions

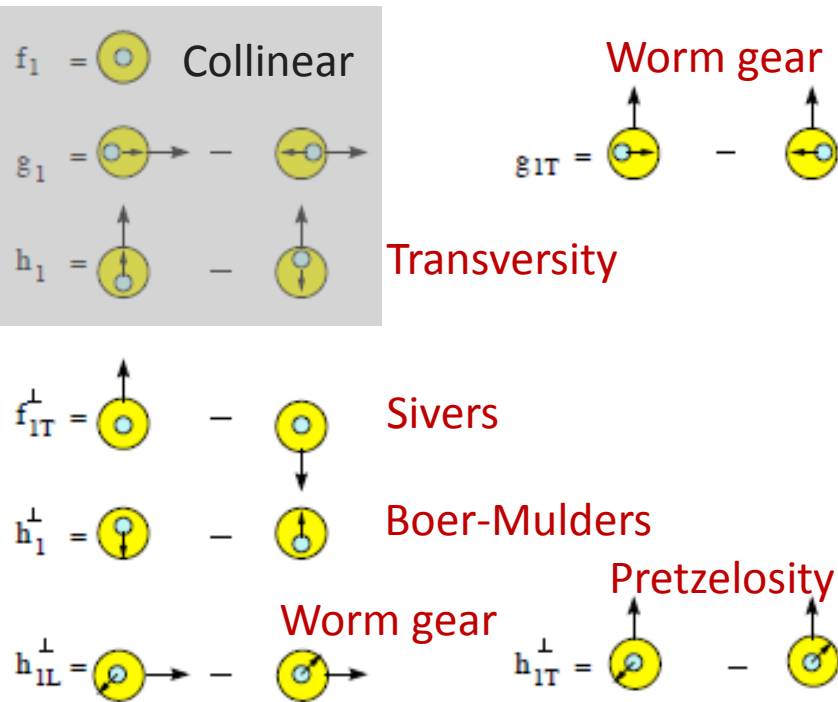

Fragmentation Functions

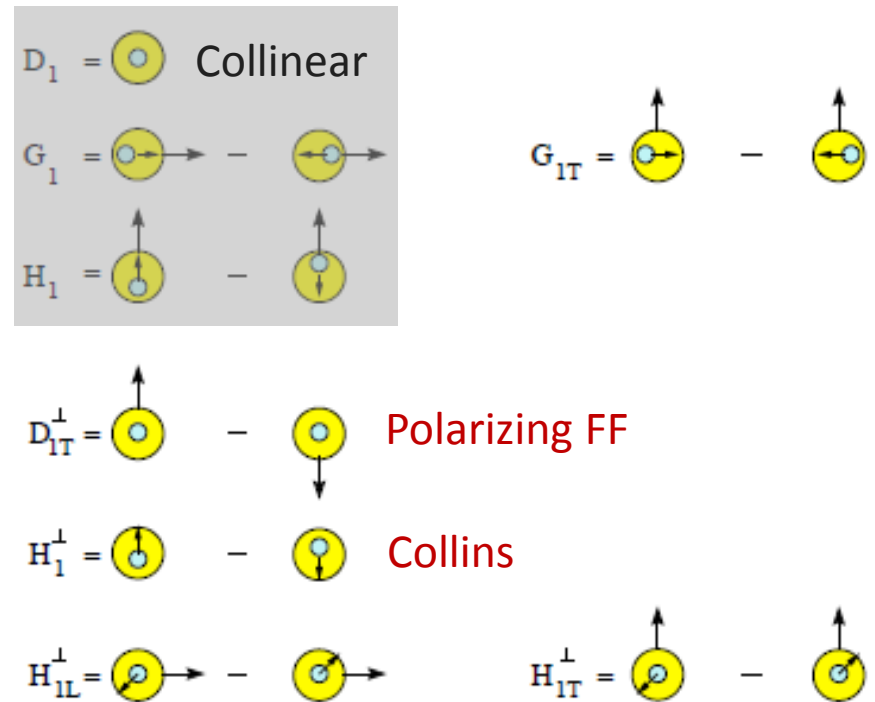

Many describe spin-momentum correlations: $S \cdot (p_1 \times p_2)$



Example: Exploring spatial distributions

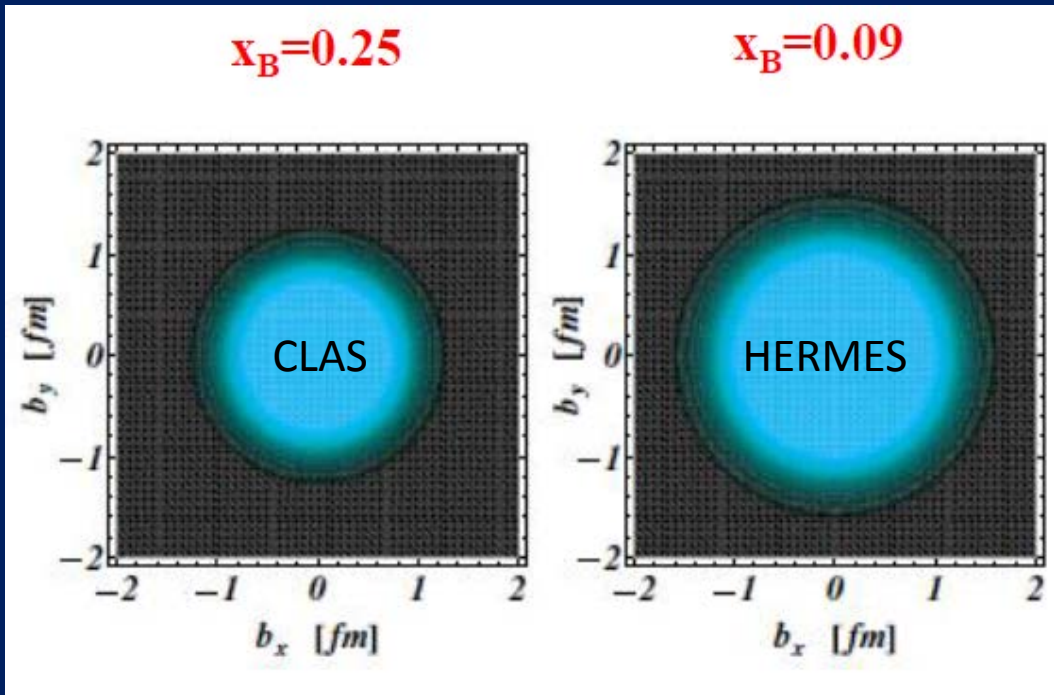

Guidal, Moutarde,
Vanderhaeghen,
Rept. Prog. Phys. 76 (2013) 066202

Related talks by N. d'Hose, P.
Kroll, G. Goldstein, A.
Mukherjee, S. Pisano, A.
Kim, A. Movsisyan, O. Eyser

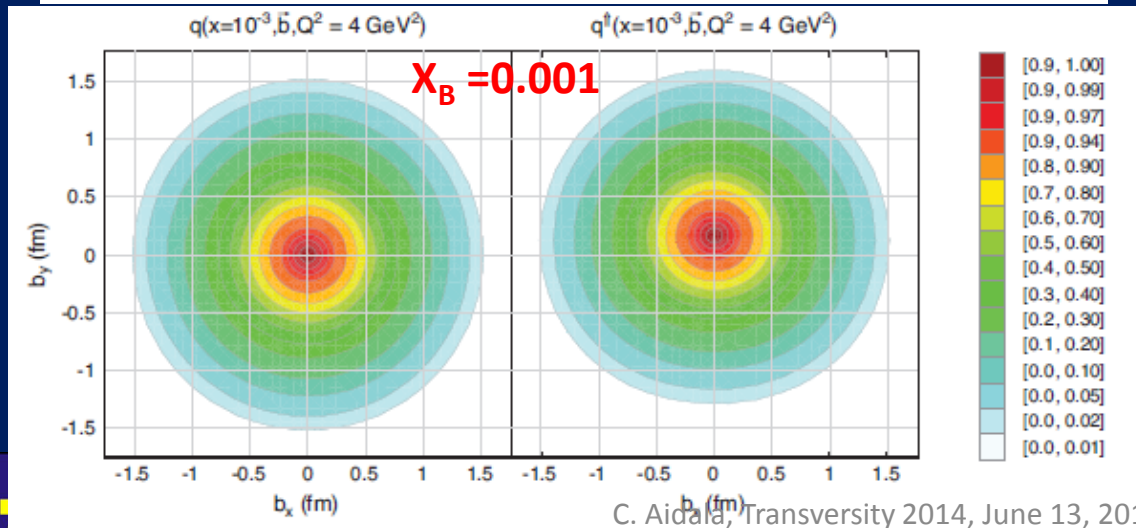

Mueller, 2011

Slide from N. d'Hose (backups)

Example: Progress in lattice

Recent progress in LQCD suggests the possibility to calculate the x -dependence of parton distributions

Slide from J.-C. Peng

PRL 110, 262002 (2013)

PHYSICAL REVIEW LETTERS

week ending
28 JUNE 2013

Parton Physics on a Euclidean Lattice

Xiangdong Ji^{1,2}

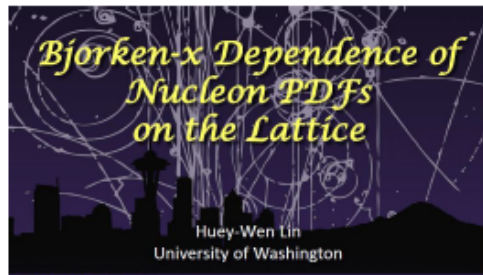

The x -dependence of the quark and antiquark transversity distributions can be calculated (not just their moments)

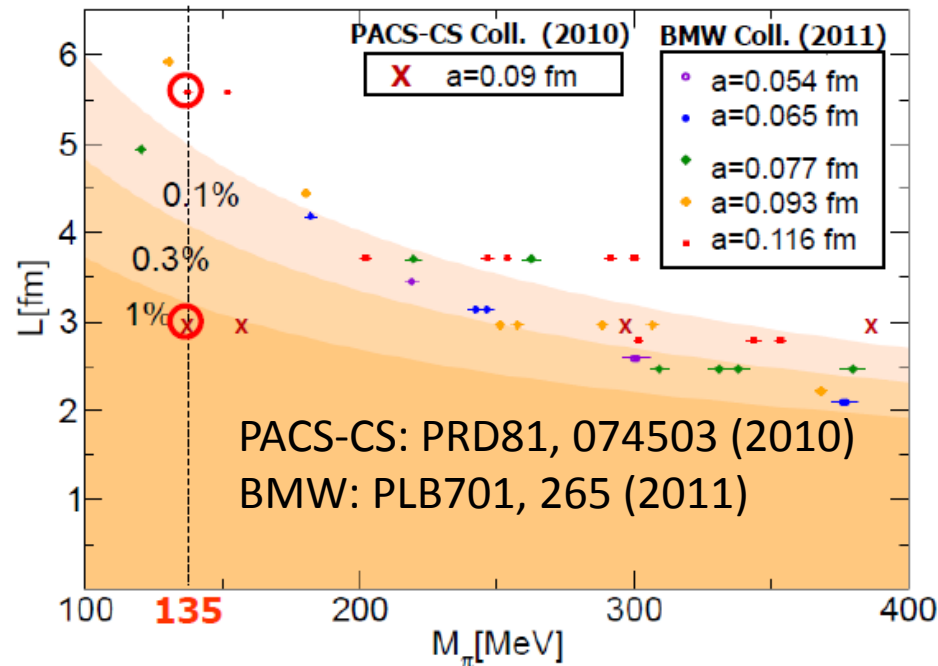

T. Hatsuda,
PANIC 2011

Example: Effective field theories

Soft Collinear Effective Theory
 – p_T distribution for $gg \rightarrow \text{Higgs}$

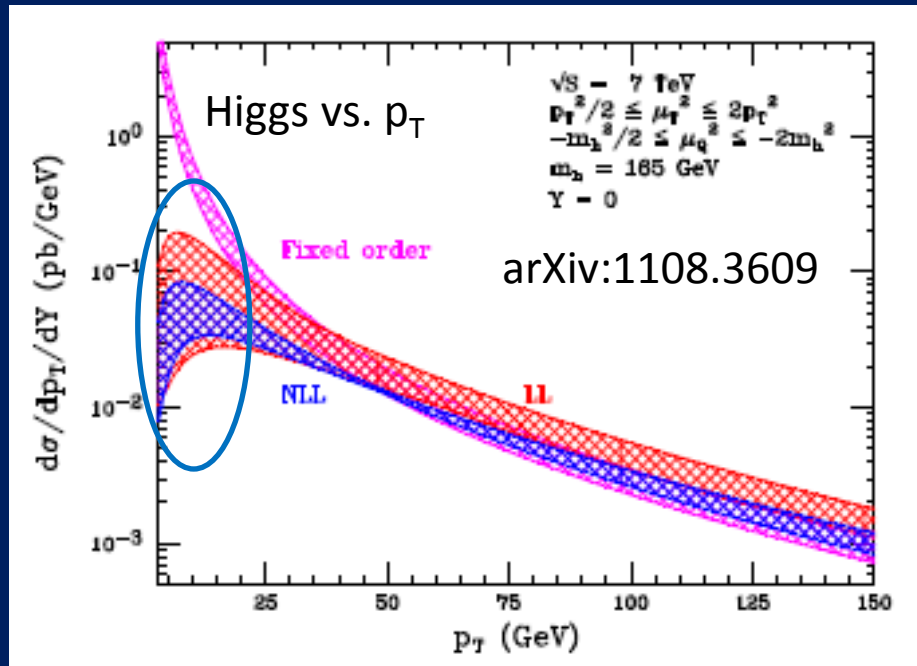

TRANSVERSE MOMENTUM DISTRIBUTIONS FROM EFFECTIVE FIELD THEORY

Sonny Mantry*

University of Wisconsin at Madison
 Madison, WI 53706, USA
 mantry147@gmail.com

Frank Petriello

High Energy Physics Division, Argonne National Laboratory
 Argonne, IL 60439, USA

Department of Physics & Astronomy, Northwestern University
 Evanston, IL 60208, USA
 f-petriello@northwestern.edu

Related talks by I. Scimemi, M. Echevarria, A. Idilbi



Example: Effective field theories

Soft Collinear Effective Theory
 – p_T distribution for $gg \rightarrow \text{Higgs}$

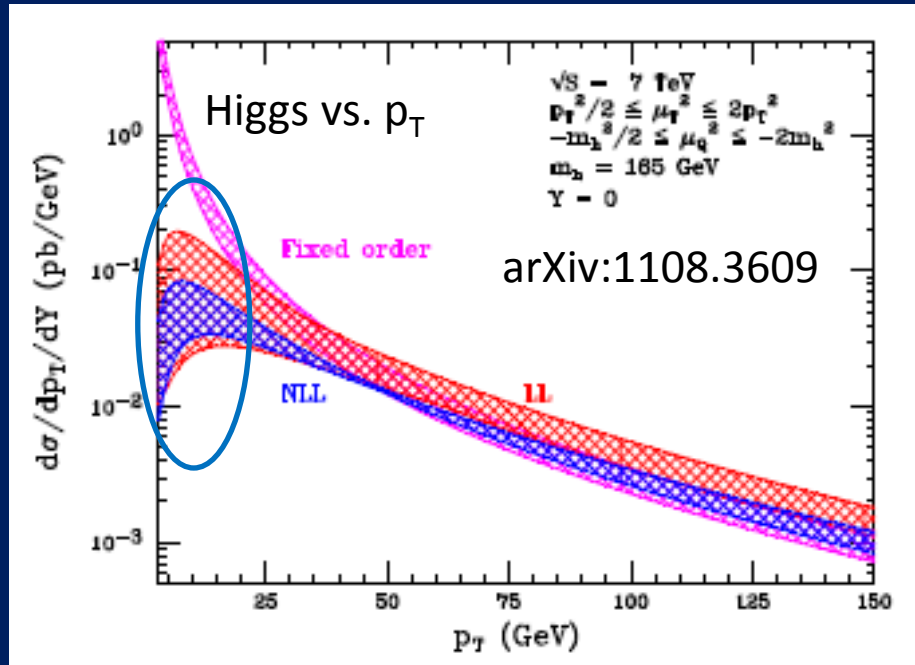

TRANSVERSE MOMENTUM DISTRIBUTIONS FROM EFFECTIVE FIELD THEORY

Sonny Mantry*

University of Wisconsin at Madison
 Madison, WI 53706, USA
 mantry147@gmail.com

Frank Petriello

High Energy Physics Division, Argonne National Laboratory
 Argonne, IL 60439, USA

Department of Physics & Astronomy, Northwestern University
 Evanston, IL 60208, USA
 f-petriello@northwestern.edu

“Modern-day ‘testing’ of (perturbative) QCD is as much about pushing the boundaries of its applicability as about the verification that QCD is the correct theory of hadronic physics.”

– G. Salam, hep-ph/0207147 (DIS2002 proceedings)

Experimental advances

- More sophisticated observables
 - E.g. angular distributions, spin dependence, multiparticle final states, . . .
 - Often sensitive to parton *dynamics*
- Multidifferential measurements
 - E.g. simultaneously in x , Q^2 , p_T

→ Demand more of theoretical calculations!



Multidifferential data: SIDIS

Talks by M. Contalbrigo, A. Bressan, G. Karyan, N. Makke, B. Parsamyan, C. Braun, C. van Hulse, A. Puckett, S. Pisano; O. Eyser

O. Gonzalez Hernandez SIDIS phenomenology talk:
1341 points
HERMES, 5385 points
COMPASS!

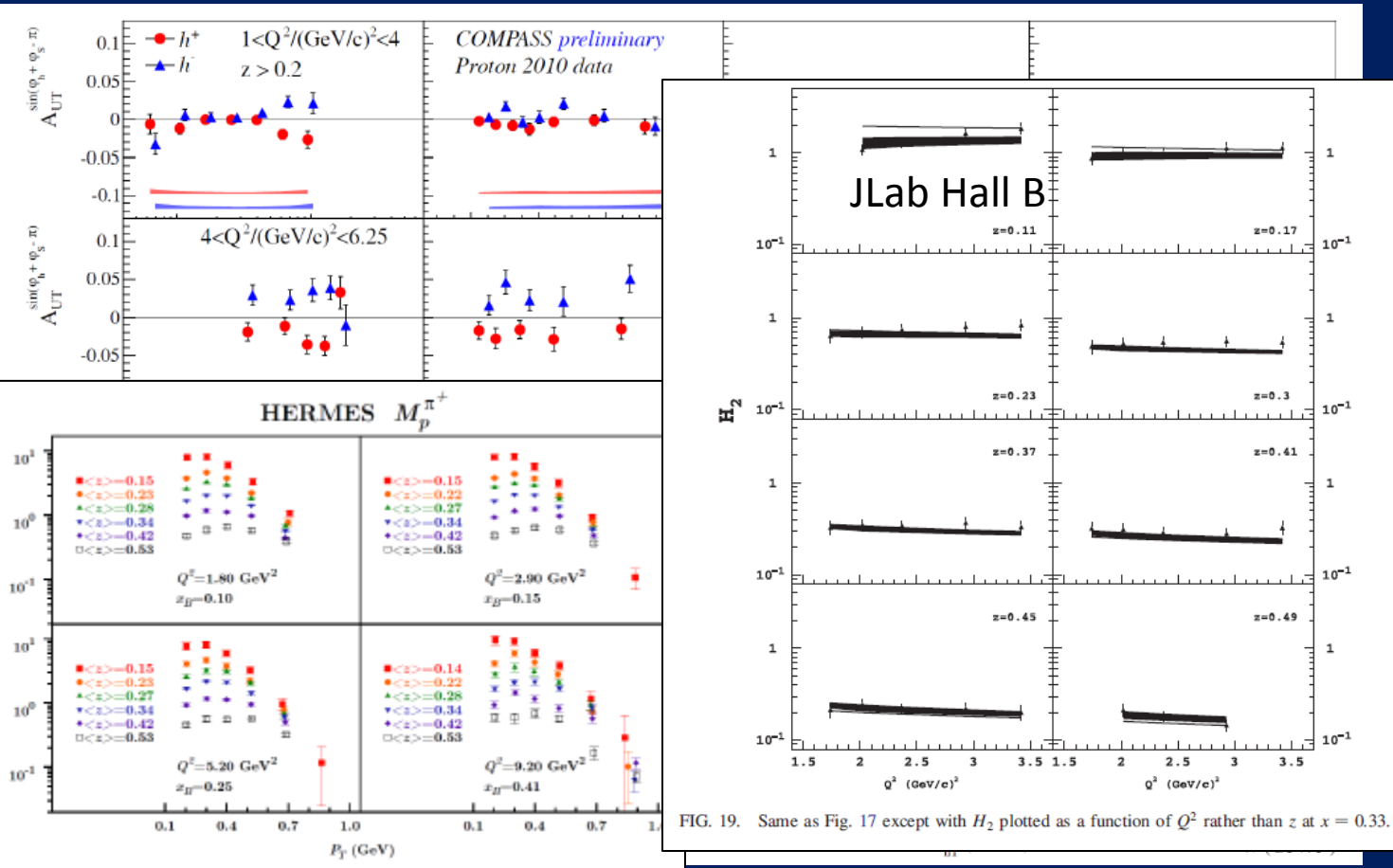

FIG. 19. Same as Fig. 17 except with H_2 plotted as a function of Q^2 rather than z at $x = 0.33$.



Multidifferential data: E866 D-Y

From J. Webb
thesis.
1 of 26 pages(!)
of similar tables.

D-Y cross section
for p+p, p+d
multidifferential
in M , x_F , p_T

Table 5.10: continued

1.75-2.00	1.88	4.77	0.62	24.499	1.69e-01	2.32e-02	8.97e-03
2.00-2.50	2.22	4.71	0.61	24.381	6.25e-02	8.96e-03	3.70e-03
2.50-3.00	2.68	4.71	0.63	24.876	2.10e-02	5.21e-03	2.21e-03
3.00-3.50	3.19	4.94	0.61	24.447	9.63e-03	3.94e-03	1.46e-03
3.50-4.00	3.76	4.33	0.57	22.878	2.57e-03	2.57e-03	5.88e-04
p_T [GeV]	$\langle p_T \rangle$	$\langle M \rangle$	$\langle x_F \rangle$	$\langle E \rangle$	$5.20 \leq M_{\mu^+\mu^-} \leq 6.20$	Stat. Error.	Syst. Error
0.00-0.25	0.16	5.71	0.62	24.865	8.35e-01	6.26e-02	3.81e-02
0.25-0.50	0.39	5.71	0.62	24.850	1.01e+00	4.44e-02	4.13e-02
0.50-0.75	0.62	5.71	0.62	24.878	8.12e-01	3.13e-02	3.61e-02
0.75-1.00	0.87	5.72	0.62	24.719	5.50e-01	2.43e-02	2.00e-02
1.00-1.25	1.12	5.72	0.62	24.580	3.68e-01	1.77e-02	1.26e-02
1.25-1.50	1.37	5.76	0.62	24.669	2.04e-01	1.23e-02	7.21e-03
1.50-1.75	1.62	5.69	0.62	24.742	1.18e-01	9.19e-03	6.14e-03
1.75-2.00	1.87	5.68	0.61	24.344	7.54e-02	6.63e-03	4.55e-03
2.00-2.50	2.22	5.72	0.60	24.003	2.57e-02	2.60e-03	1.12e-03
2.50-3.00	2.70	5.78	0.60	24.191	9.18e-03	1.65e-03	6.38e-04
3.00-3.50	3.13	5.77	0.60	24.291	1.87e-03	7.23e-04	2.85e-04
3.50-4.00	3.80	5.63	0.60	24.228	1.39e-03	6.01e-04	2.14e-04
4.00-5.00	4.28	5.44	0.61	24.584	6.68e-04	4.77e-04	2.73e-04
5.00-6.00	5.20	5.20	0.58	23.539	8.94e-05	8.94e-05	4.32e-05
p_T [GeV]	$\langle p_T \rangle$	$\langle M \rangle$	$\langle x_F \rangle$	$\langle E \rangle$	$6.20 \leq M_{\mu^+\mu^-} \leq 7.20$	Stat. Error.	Syst. Error
0.00-0.25	0.16	6.67	0.62	24.848	3.72e-01	2.94e-02	2.95e-02
0.25-0.50	0.39	6.68	0.62	25.117	4.08e-01	2.24e-02	1.52e-02
0.50-0.75	0.63	6.68	0.62	25.057	3.27e-01	1.51e-02	1.14e-02
0.75-1.00	0.87	6.68	0.62	24.953	2.68e-01	1.16e-02	8.92e-03
1.00-1.25	1.12	6.67	0.62	25.048	1.83e-01	8.74e-03	7.14e-03



Multidifferential data: $e+e-$

Talks by I. Garzia, M. Grosse Perdekamp, F. Giordano

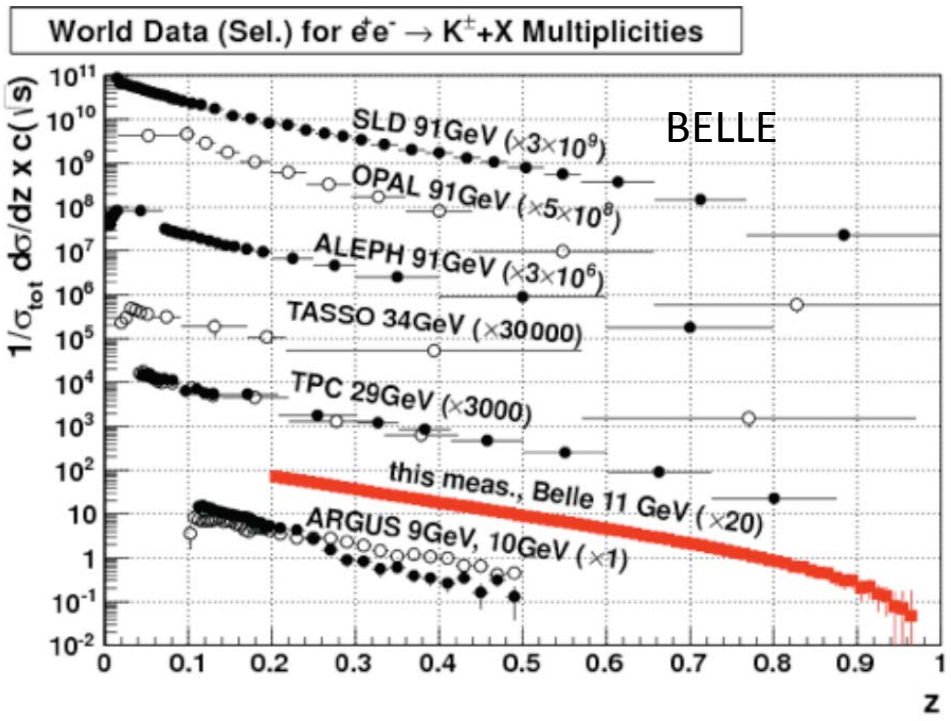
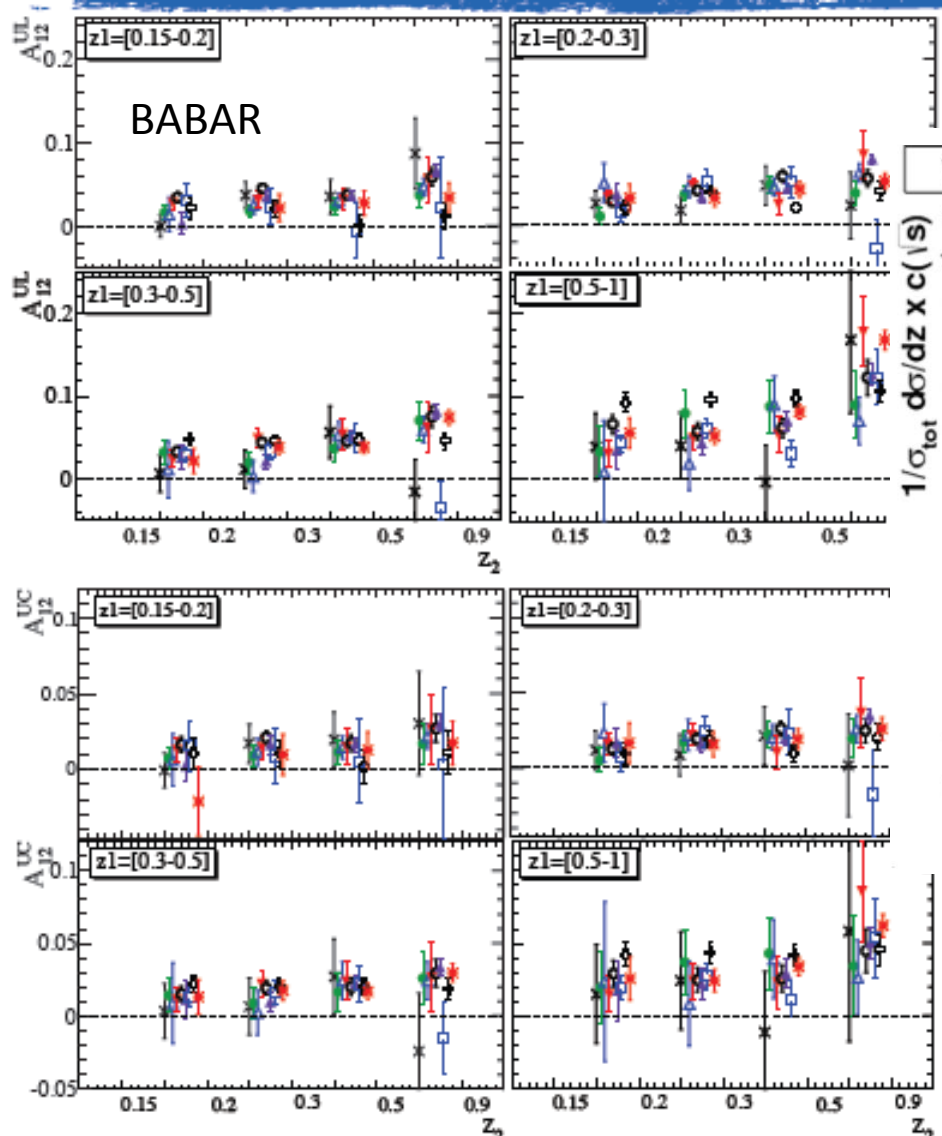

(Okay, the BELLE hadron multiplicities aren't multidifferential (yet), but they're still quite impressive!)

Understanding the theory doesn't mean knowing how to do phenomenology

- Current example: TMD evolution . . .
 - Talks by S. Melis, J. Collins, W. Vogelsang, L. Gamberg, I. Scimemi, M. Echevarria, A. Prokudin, A. Signori, O. Gonzalez Hernandez, O. Teryaev (9 presentations—only 1 at Transversity 2011!)
- Lots of (sometimes animated!) debates
 - Means we've now advanced to the point of worrying about things we didn't even consider several years ago → Progress!



Gauge links have physical consequences

We have ignored here the subtleties needed to make this a gauge invariant definition: an appropriate path ordered exponential of the gluon field is needed [18].

Collins, 1993

gauge links have physical consequences;
quark models for non vanishing Sivers function,
SIDIS final state interactions

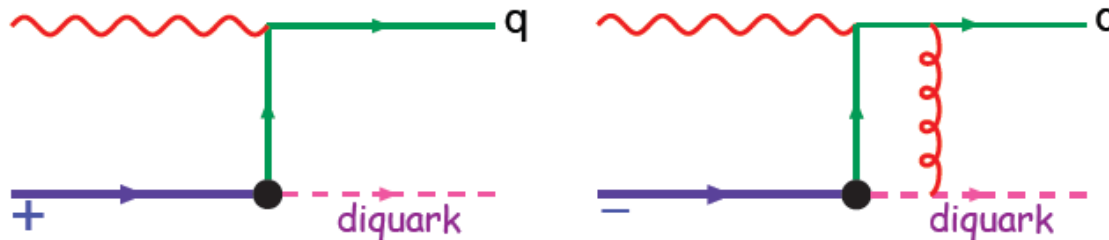

Brodsky, Hwang, Schmidt, PL B530 (2002) 99 - Collins, PL B536 (2002) 43

An earlier proof that the Sivers asymmetry vanishes because of time-reversal invariance is invalidated by the path-ordered exponential of the gluon field in the operator definition of parton densities. Instead, the time-reversal argument shows that the Sivers asymmetry is reversed in sign in hadron-induced hard processes (e.g., Drell-Yan), thereby violating naive universality of parton densities. Previous phenomenology with time-reversal-odd parton densities is therefore validated.

$$[f_{1T}^{q\perp}]_{\text{SIDIS}} = -[f_{1T}^{q\perp}]_{\text{DY}}$$

From M.
Anselmino

Talks on polarized
D-Y by L. Bland, A.
Vossen, J.-C. Peng,
M. Chiosso, + SIDIS
Sivers talks . . .

Talks related to
Wilson lines by M.
Buffing, F. van der
Veken

Physical consequences of a gauge-invariant quantum theory: Aharonov-Bohm (1959)

Wikipedia:

“The Aharonov–Bohm effect is important conceptually because it bears on three issues apparent in the recasting of (Maxwell's) classical electromagnetic theory as a gauge theory, which before the advent of quantum mechanics could be argued to be a mathematical reformulation with no physical consequences. The Aharonov–Bohm thought experiments and their experimental realization imply that the issues were not just philosophical.

The three issues are:

- whether potentials are "physical" or just a convenient tool for calculating force fields;
- whether action principles are fundamental;
- the principle of locality.”



Physical consequences of a gauge-invariant quantum theory: Aharonov-Bohm (1959)

Physics Today, September 2009 :

The Aharonov–Bohm effects: Variations on a subtle theme,
by Herman Batelaan and Akira Tonomura.

“Aharonov stresses that the arguments that led to the prediction of the various electromagnetic AB effects apply equally well to any other gauge-invariant quantum theory. In the standard model of particle physics, the strong and weak nuclear interactions are also described by gauge-invariant theories. So one may expect that particle-physics experimenters will be looking for new AB effects in new domains.”



Physical consequences of a gauge-invariant quantum theory: Aharonov-Bohm effect in QCD!!

**Deep-inelastic lepton-nucleon scattering:
Attractive final-state interactions**

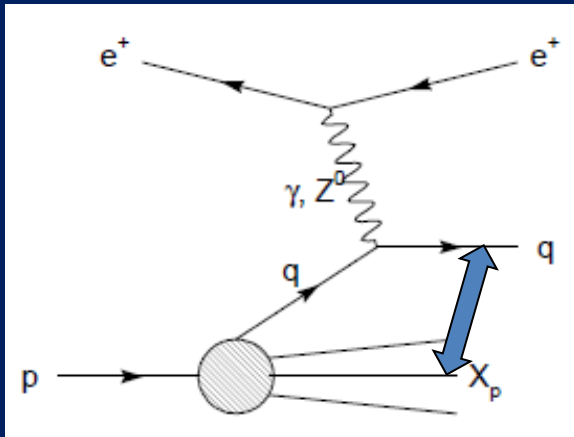

**Quark-antiquark annihilation to leptons:
Repulsive initial-state interactions**

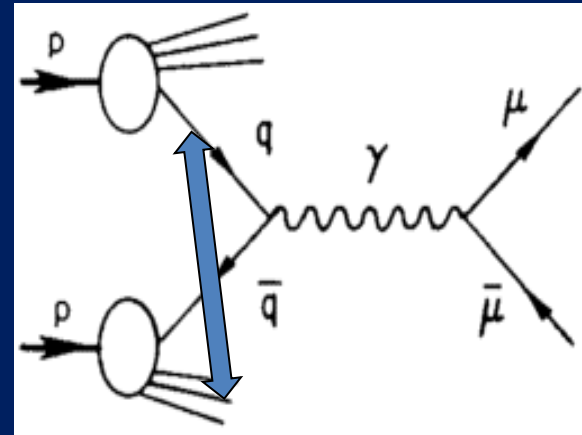

As a result:

$$\text{Sivers}|_{\text{DIS}} = -\text{Sivers}|_{\text{DY}}$$

See e.g. Pijlman, hep-ph/0604226
or Sivers, arXiv:1109.2521

*Physical consequences of a
gauge-invariant quantum theory:
Aharonov-Bohm effect in QCD!!*

**Deep-inelastic lepton-nucleon
scattering:
Attractive final-state interactions**

**Quark-antiquark annihilation to
leptons:
Repulsive initial-state interactions**

*Simplicity of these two processes:
Abelian vs. non-Abelian nature of the gauge
group doesn't play a major qualitative role.*

*BUT: In QCD expect additional, new effects
due to specific non-Abelian nature of the
gauge group*

As a r

ijlman,
604226

arXiv:1109.2521



QCD Aharonov-Bohm effect: Color entanglement

- 2010: Rogers and Mulders predict *color entanglement* in processes involving $p+p$ production of hadrons if quark transverse momentum taken into account
- Quarks become correlated *across* the two protons
- Consequence of QCD specifically as a *non-Abelian* gauge theory!

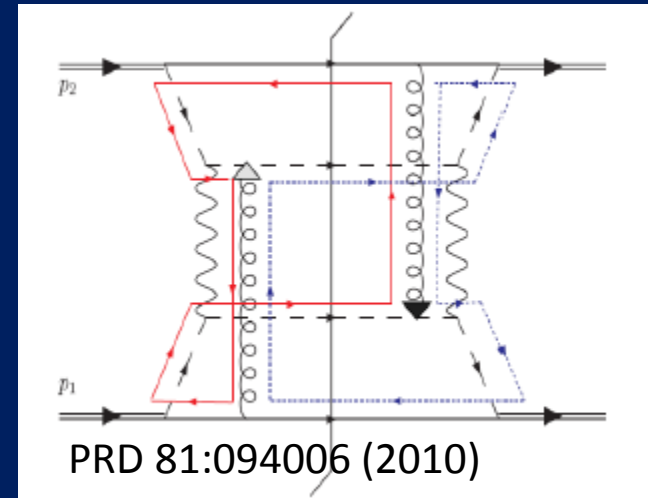

$$p + p \rightarrow h_1 + h_2 + X$$

Color flow can't be described as flow in the two gluons separately. Requires simultaneous presence of both.

QCD Aharonov-Bohm effect: Color entanglement

- 2010: Rogers and Mulders predict *color entanglement* in processes involving $n+n$ production of

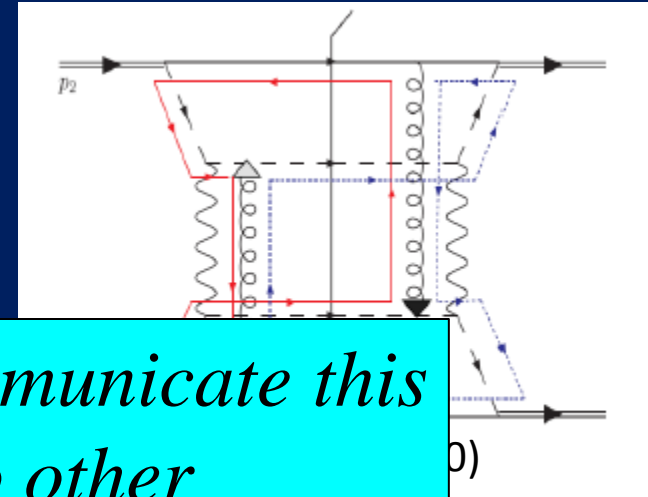

We need to refine how we communicate this fundamental physics to other communities... Every Ph.D. physicist has studied the Aharonov-Bohm effect!

- Quantum entanglement of the color flow
- Consequence of QCD specifically as a *non-Abelian* gauge theory!

Color flow can't be described as flow in the two gluons separately. Requires simultaneous presence of both.

Some thoughts on future directions . . .

4 areas I expect to come into increasing focus:

- Sea quarks
- Multiparton correlations
- Partonic structure of nuclei
- Hadronization



Diving into the sea

- There's a lot going on in there . . .
- Sometimes we focus our attention on the sea, often we neglect it



Light quark sea: Not simply gluon splitting

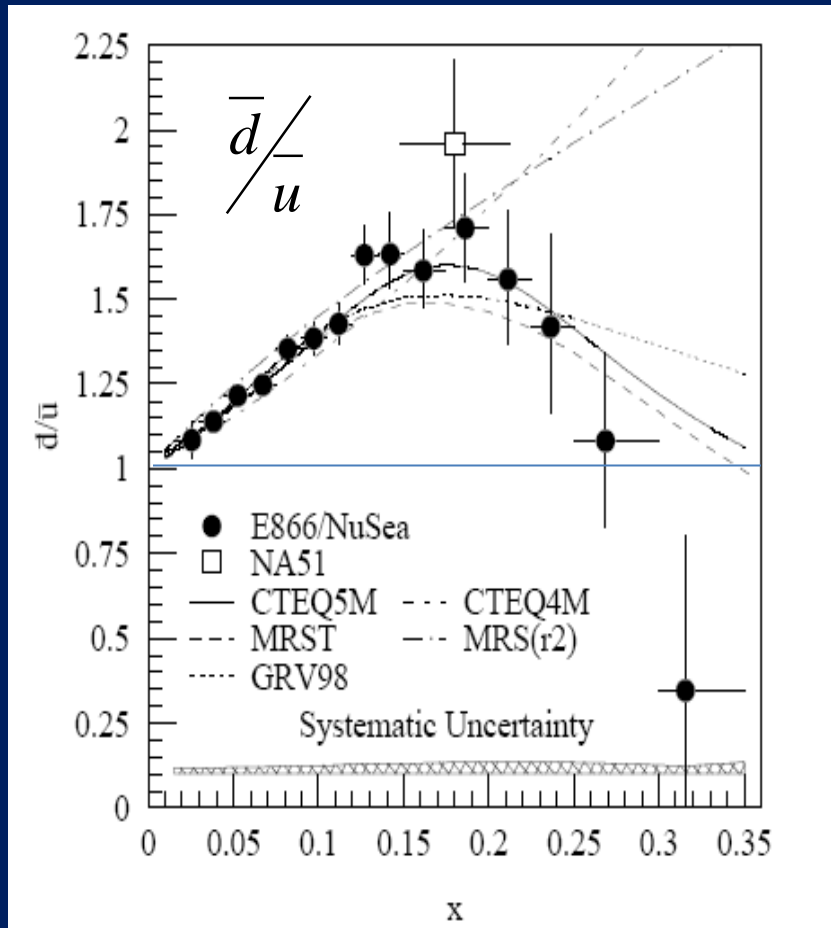

E866: PRD64, 052002 (2001)

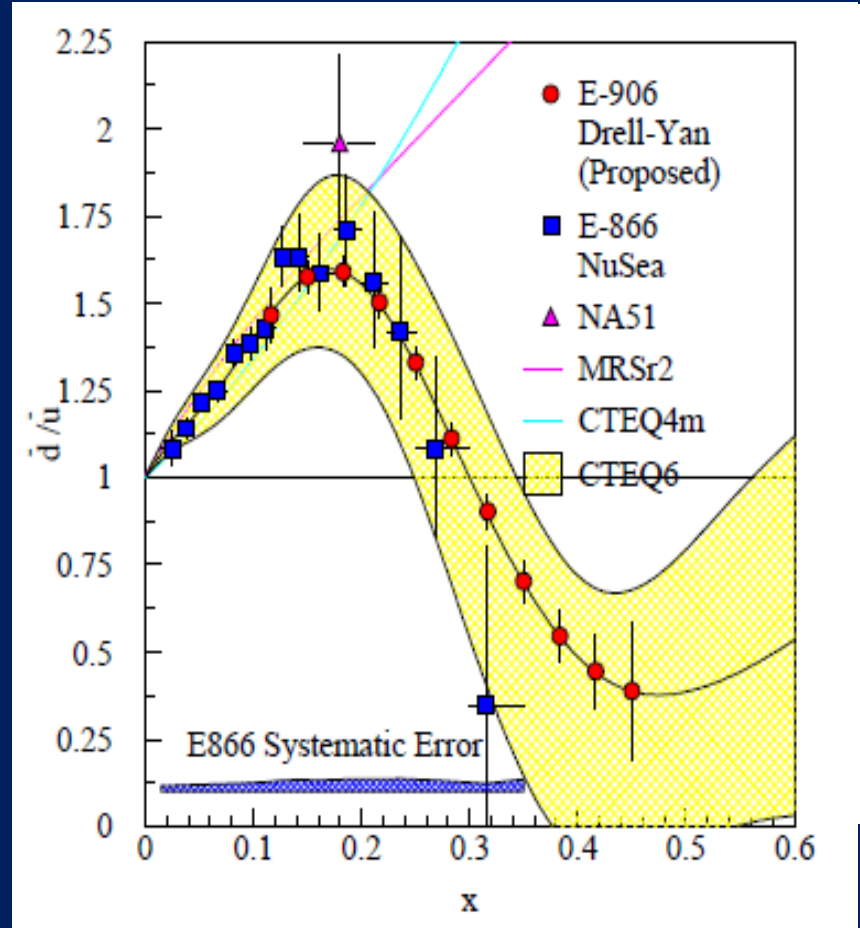

Projections for E906: Results soon!



Talk by J.-C. Peng

Light quark sea: Not simply gluon splitting

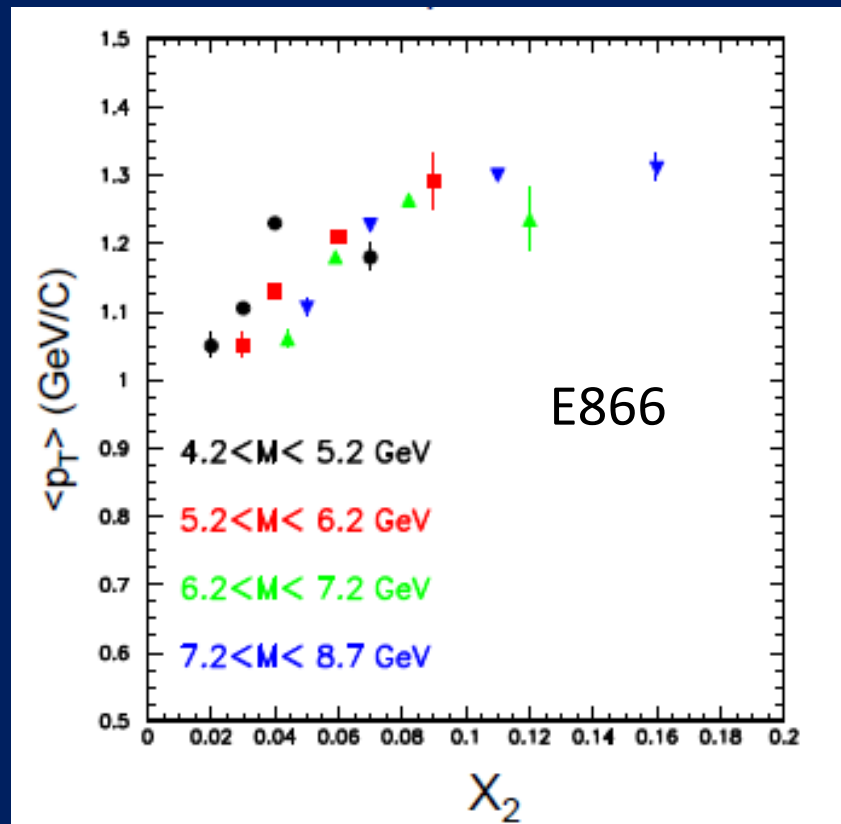
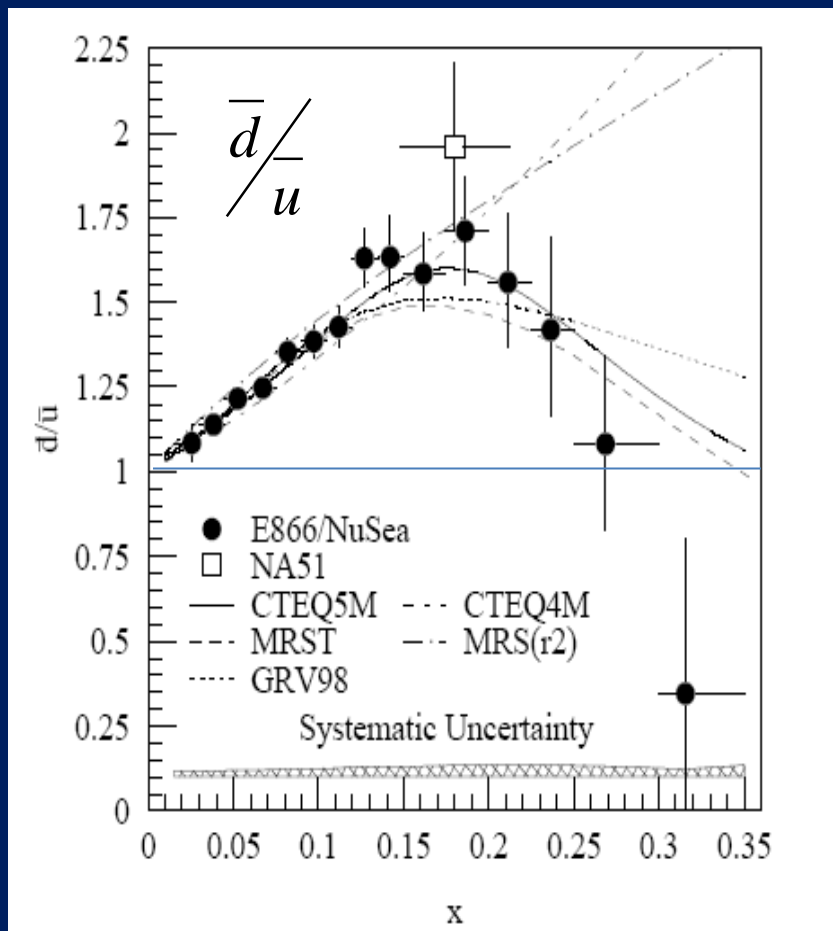

Mean p_T rises with x of sea quark?

E866: PRD64, 052002 (2001)

Talk by J.-C. Peng



Drell-Yan: Transverse momentum of valence vs. sea quarks

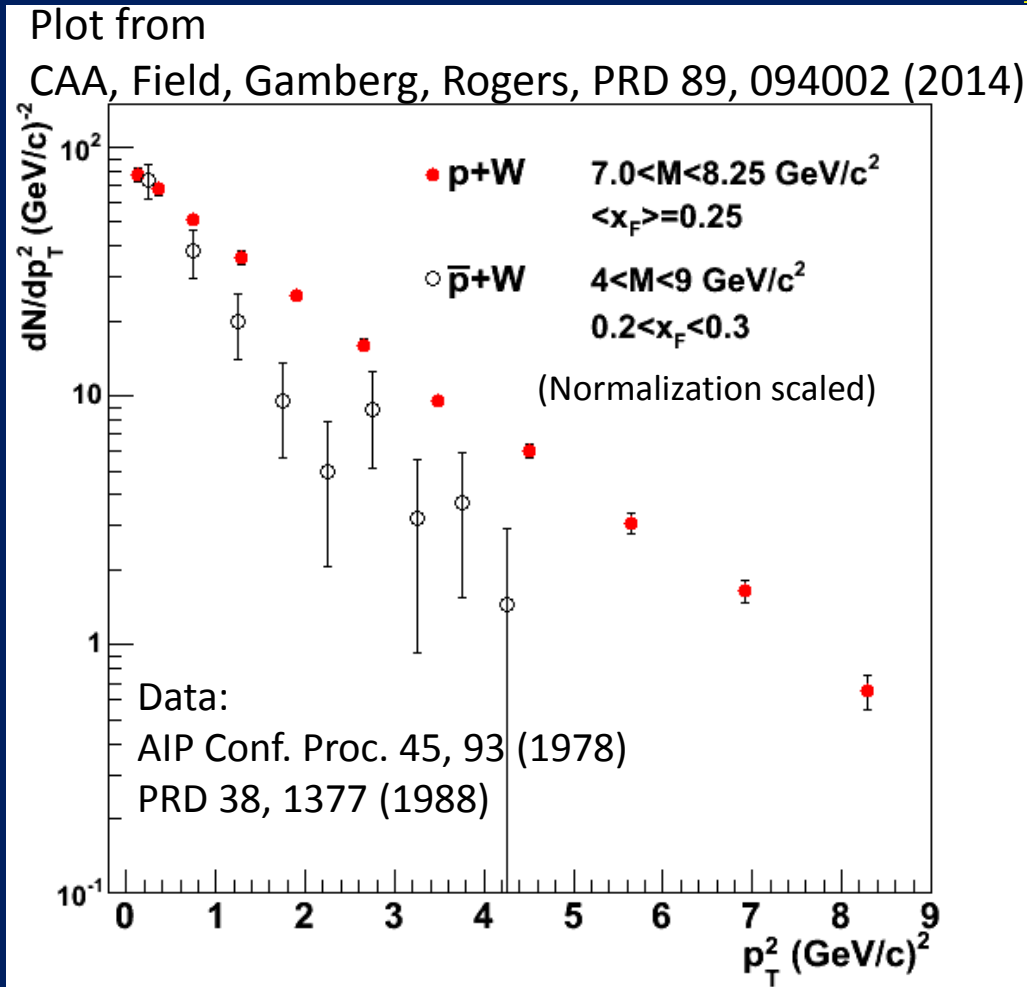

p+W: (Valence) quark from p, (sea) antiquark from W

pbar+W: (Valence) quark from W, (valence) antiquark from pbar

Different slope, although not (quite) apples-to-apples kinematics.

(Valence x sea) spectrum harder \rightarrow Larger mean k_T for sea than valence quarks?

Boer-Mulders for sea quarks small??

Transversity for sea quarks large??

E866, PRL 99, 082301 (2007);
PRL 102, 182001 (2009)

From J.-C. Peng

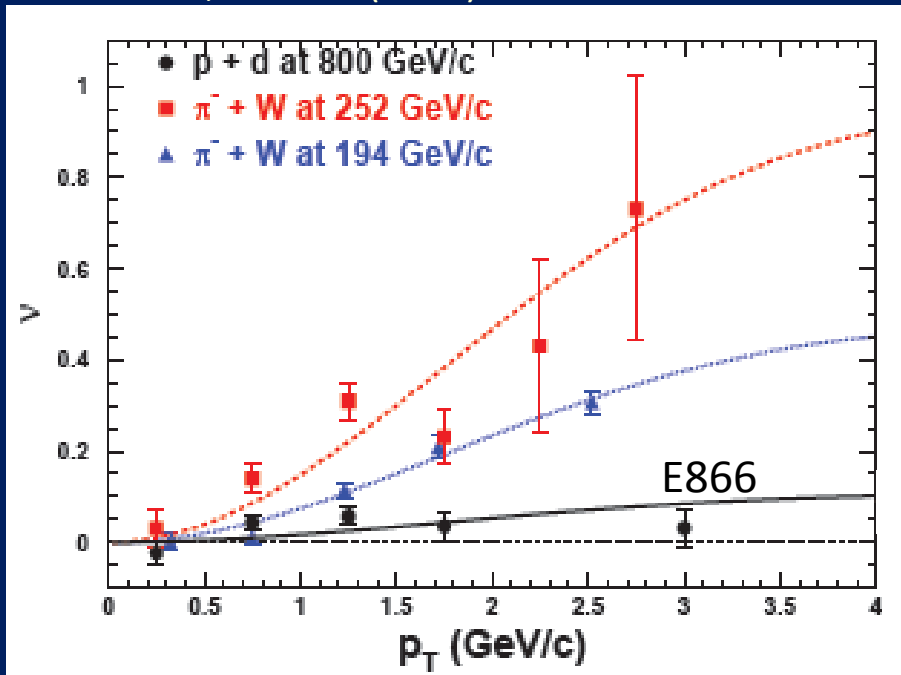

Transversity Distribution

§ Exploratory study

• We found $\delta\bar{u} < \delta\bar{d}$ with large sea asymmetry

• Chiral quark-soliton model

$$\int dx \frac{\delta\bar{u}(x) - \delta\bar{d}(x)}{g_T} \approx -0.320 \quad (18)$$

$$\int dx (\delta\bar{u}(x) - \delta\bar{d}(x)) \approx -0.082$$

B. Dressler et al.,
hep-ph/9809487

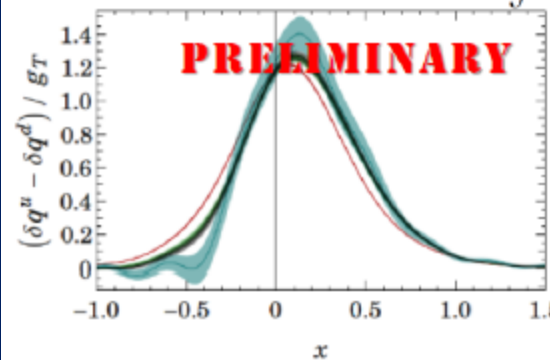

CQS model

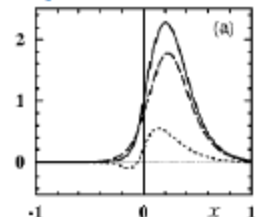

P. Schweitzer et al.
PRD 64, 034013 (2001)

Predicts large sea-quark transversity! -13

Boer - Mulders function h_1^\perp

$$v(\pi W \rightarrow \mu^+ \mu^- X) \sim [\text{valence } h_1^\perp(\pi)] * [\text{valence } h_1^\perp(p)]$$

$$v(pd \rightarrow \mu^+ \mu^- X) \sim [\text{valence } h_1^\perp(p)] * [\text{sea } h_1^\perp(p)]$$

Also P. Zavada - k_T of sea quarks in covariant approach

Need more data . . .



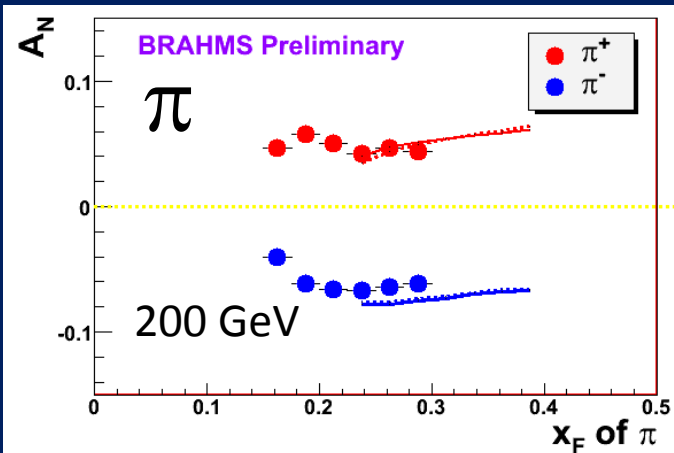

π, K, p
at 200 and
62.4 GeV

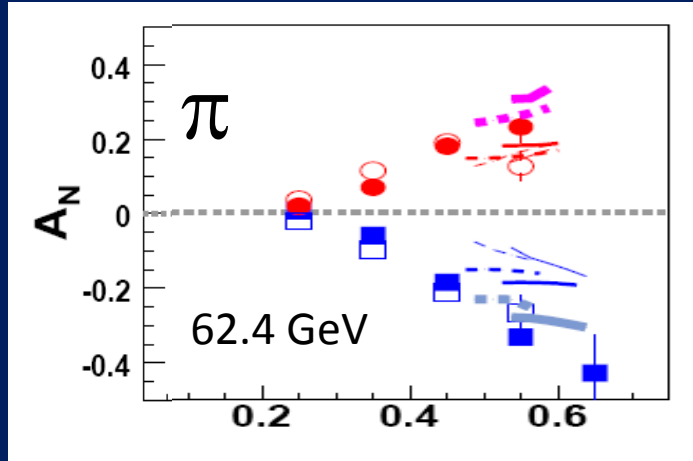

Note different scales
→

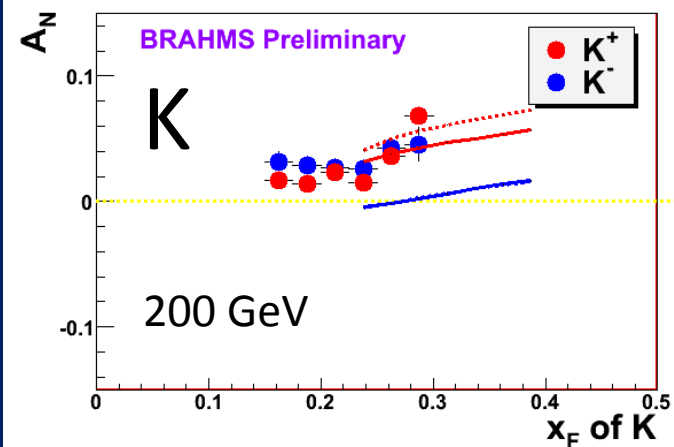

K- asymmetries
underpredicted

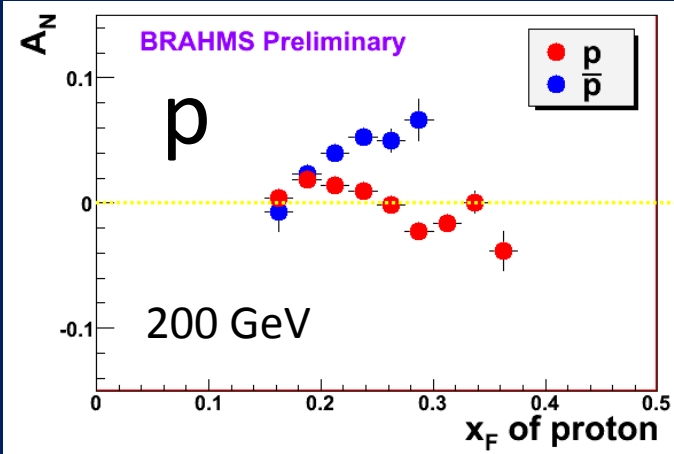
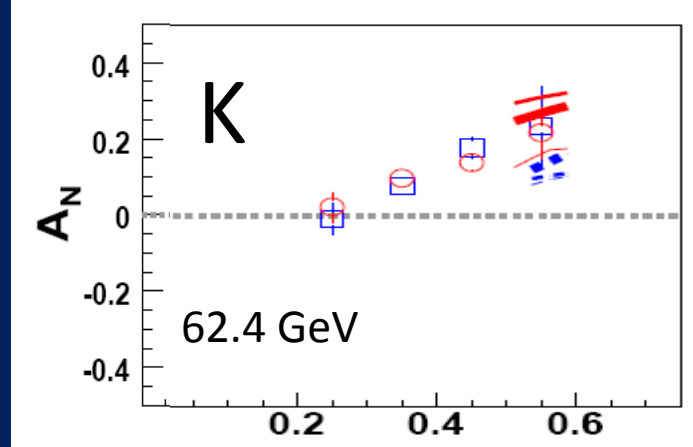

Large antiproton
asymmetry??
Unfortunately no 62.4
GeV measurement

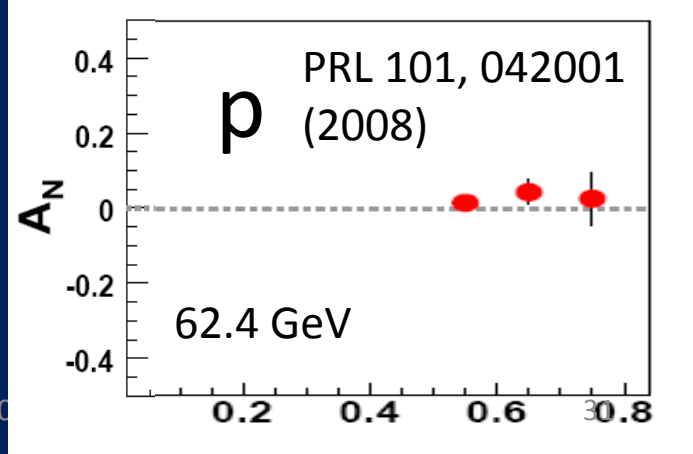

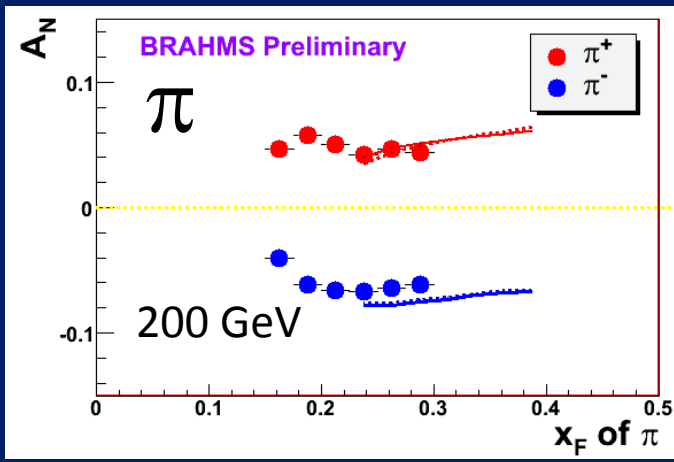

π, K, p
at 200 and
62.4 GeV

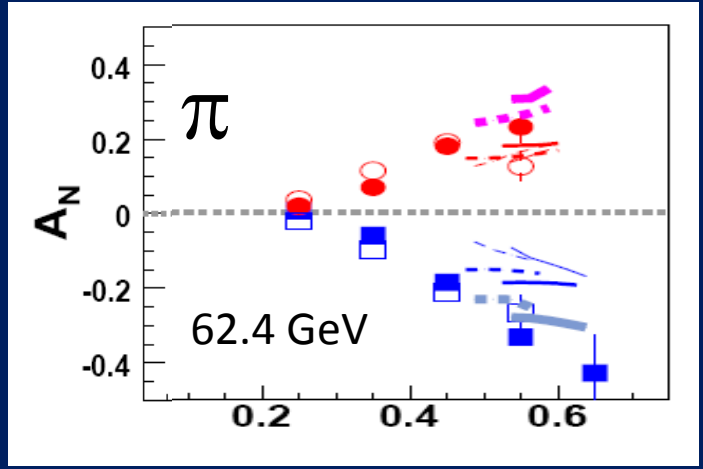

Note different scales

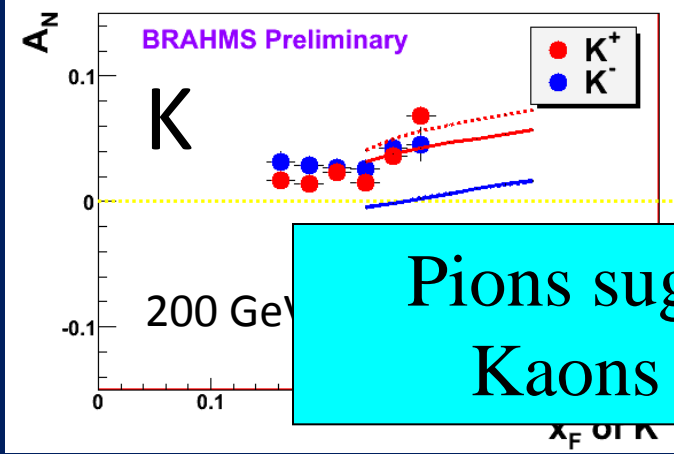

K- asymmetries
underpredicted

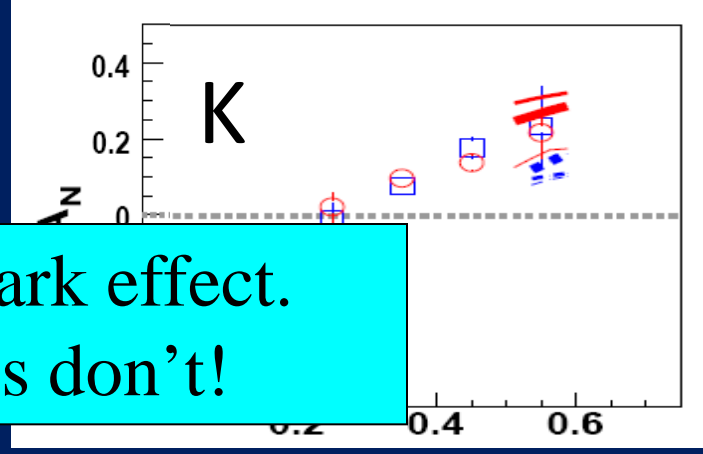

Pions suggest valence quark effect.
Kaons and (anti)protons don't!

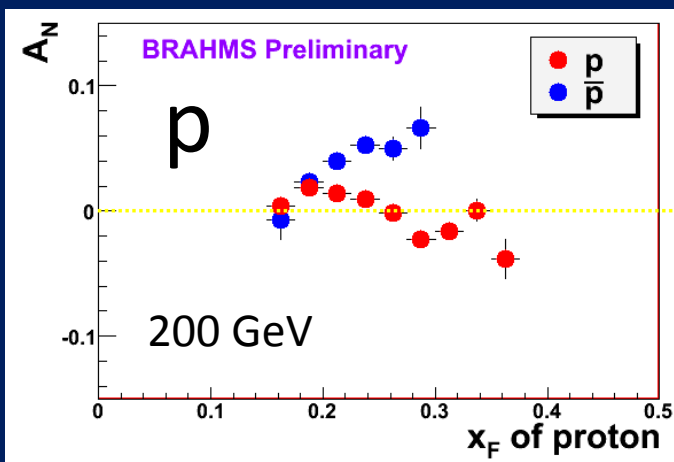

Large antiproton
asymmetry??
Unfortunately no 62.4
GeV measurement

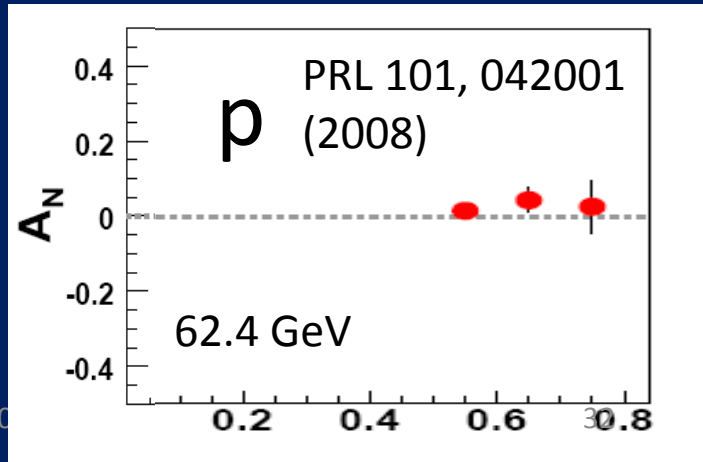

$p+p$ ηA_N larger than π^0 ?? Same?

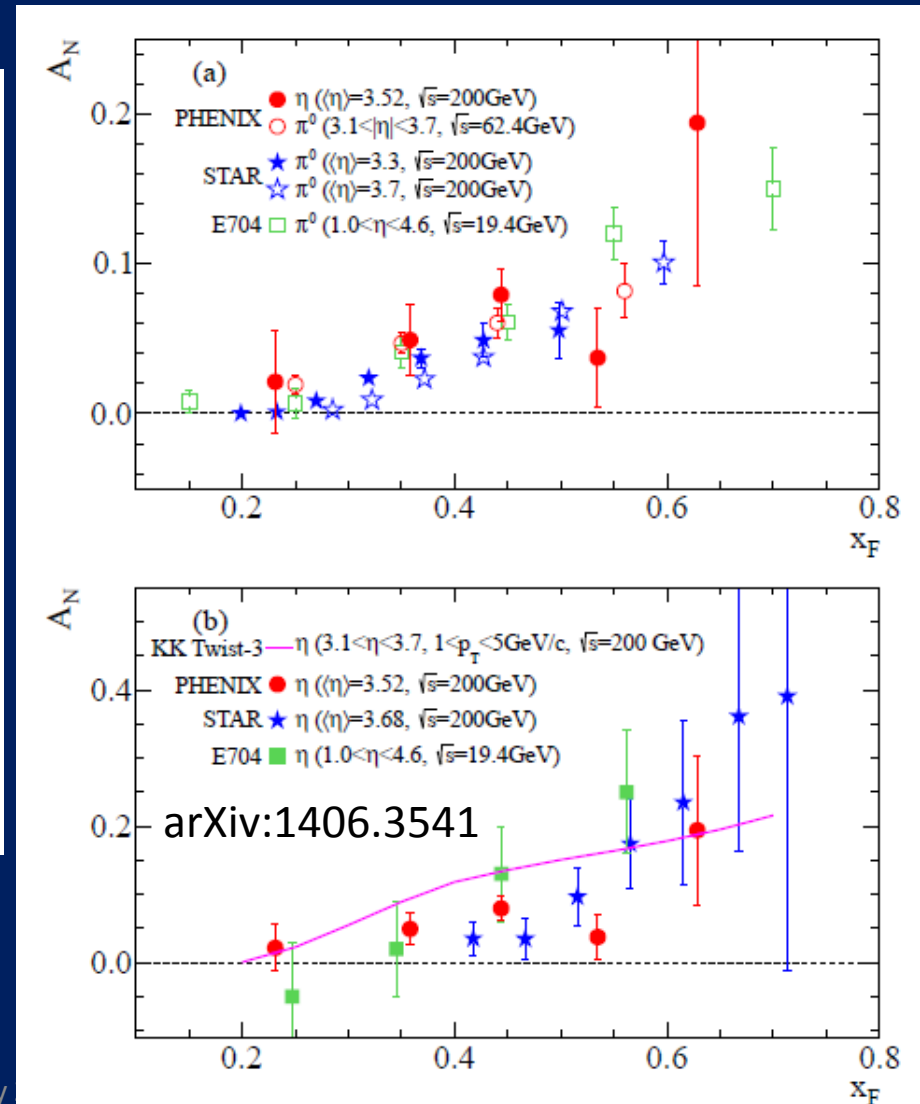
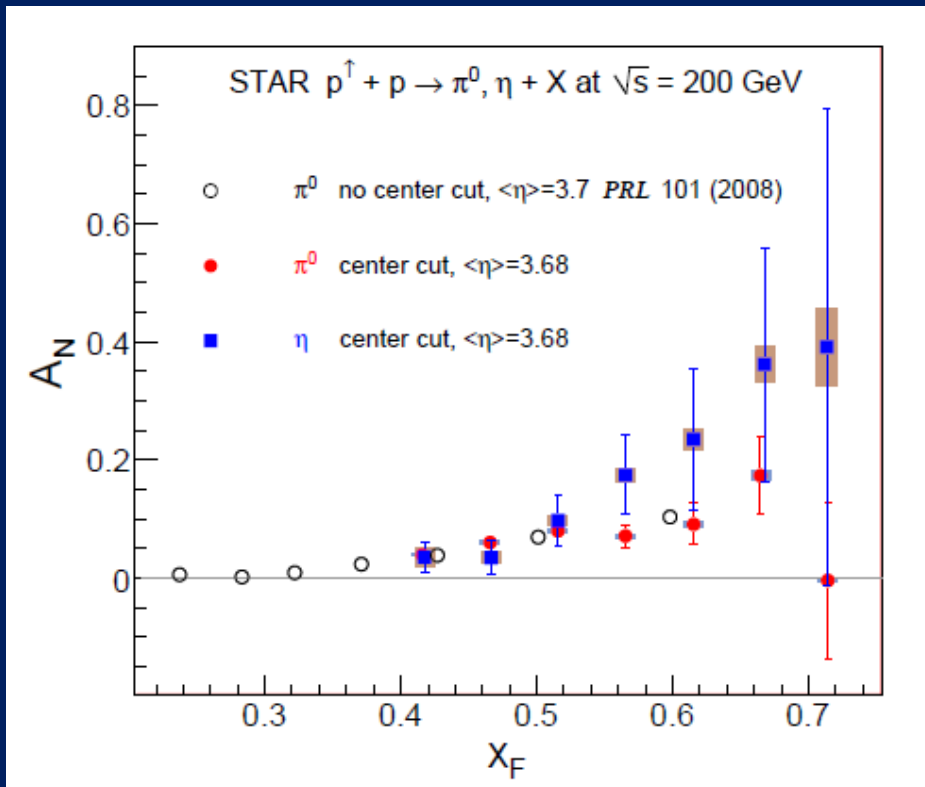

Related talks by L. Bland, D. Kleinjan,
A. Vossen, A. Ogawa, Y. Koike, D. Pitonyak,
C. Pisano



$p+p$ η A_N larger than π^0 ?? Same?

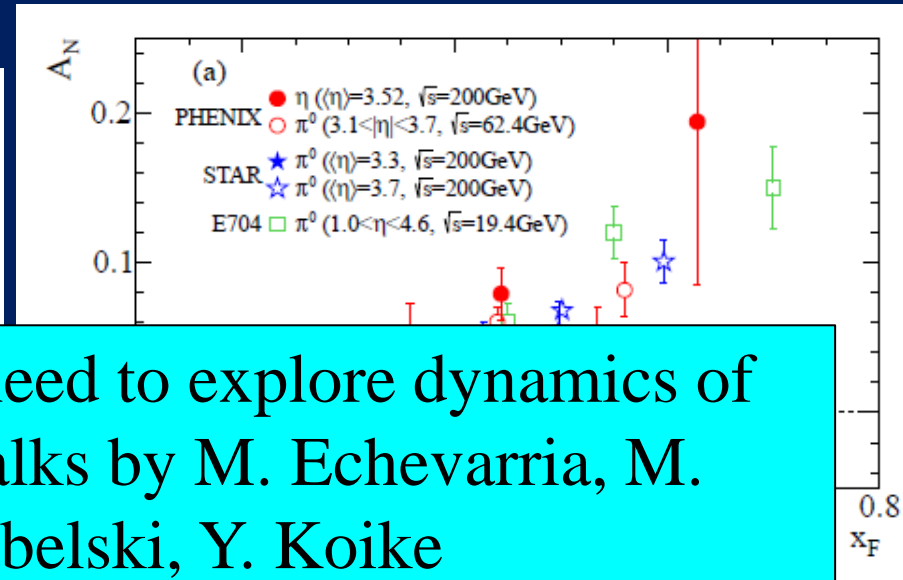
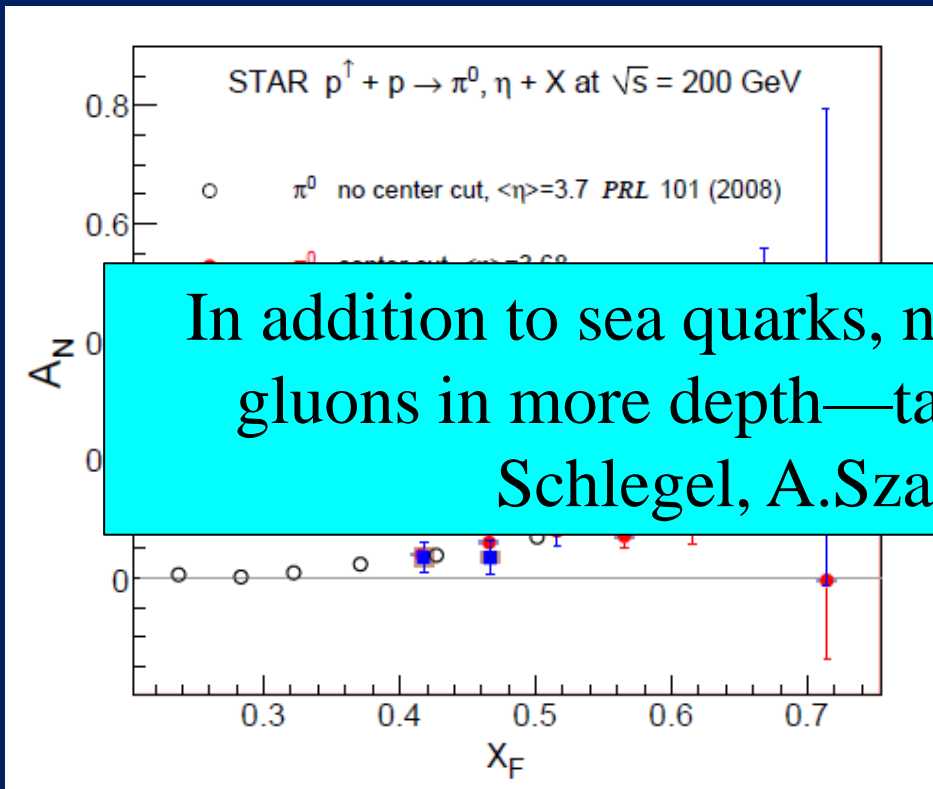

In addition to sea quarks, need to explore dynamics of gluons in more depth—talks by M. Echevarria, M. Schlegel, A. Szabelski, Y. Koike

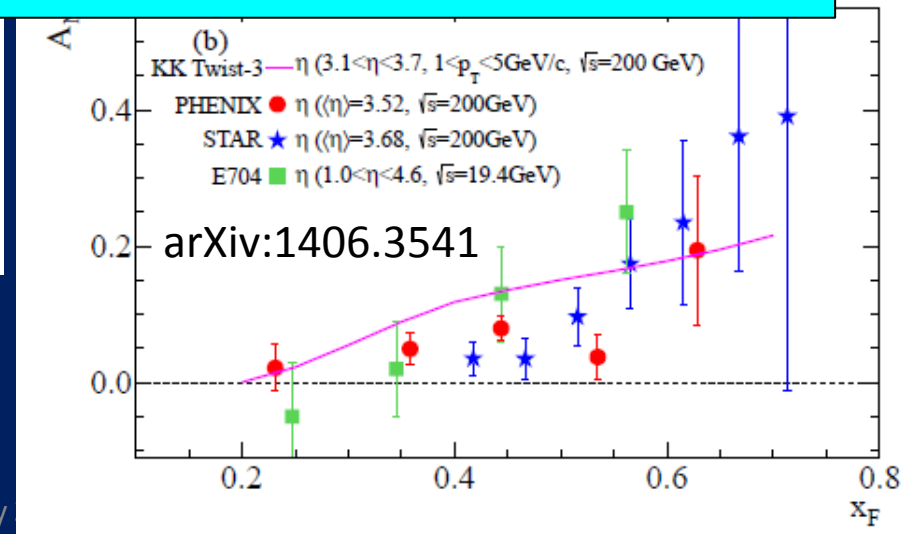

Related talks by L. Bland, D. Kleinjan, A. Vossen, A. Ogawa, Y. Koike, D. Pitonyak, C. Pisano



Partonic structure of nuclei

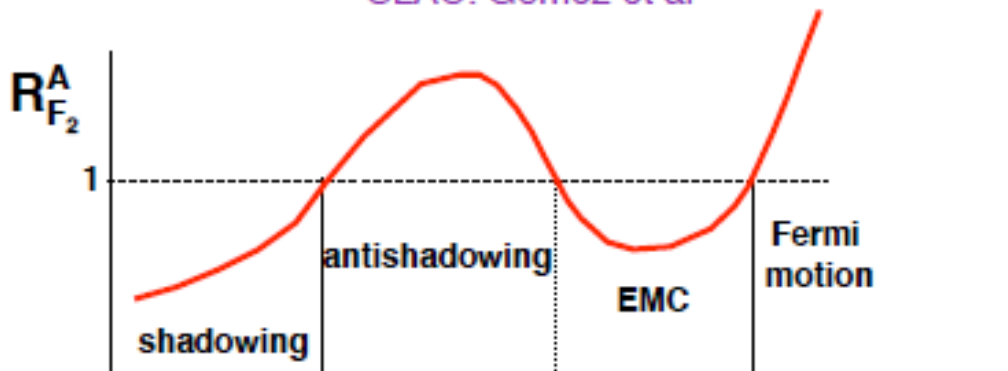
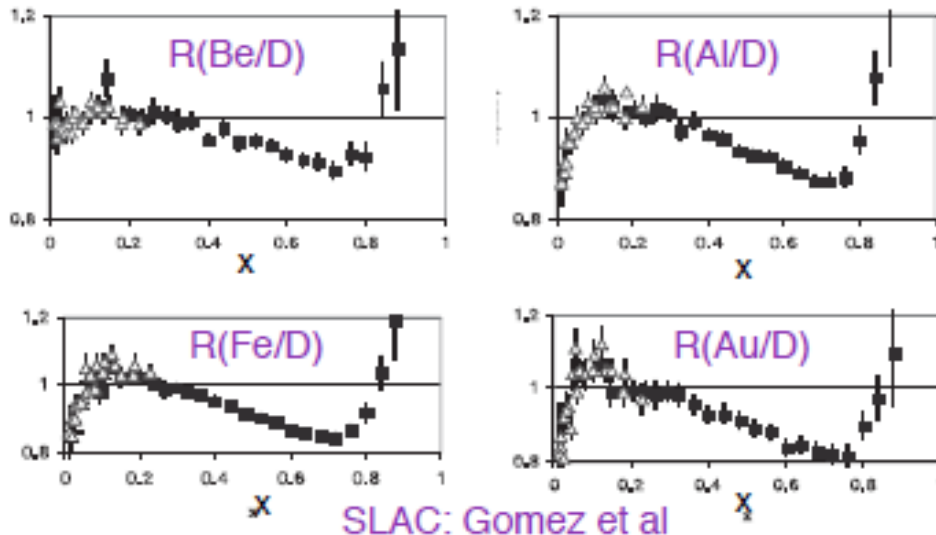

$$R_A \equiv \frac{1}{A} \frac{F_{2A}}{F_{2N}} \neq 1$$

Nuclei: Not simple superpositions of nucleons!

Rich and intriguing differences compared to free nucleons, which vary with the linear momentum fraction probed (and likely transverse momentum, impact parameter, . . .).

Related talks by E. Pace, A. Puckett

Understanding the nucleon in terms of the quark and gluon d.o.f. of QCD does NOT allow us to understand nuclei in terms of the colored constituents inside them!

Upcoming opportunities at JLab

- Tritium target approved - talk by A. Puckett
 - Can perform same measurements on mirror nuclei ${}^3\text{H}$ and ${}^3\text{He}$
- JLab Hall A will take DIS data on tritium target in 2015
 - Same experiment will measure DIS on ${}^3\text{He}$
 - Explore nuclear effects, isospin symmetry assumptions, neutron structure, . . .
- Other tritium experiments to follow
- We need many similar apples-to-apples comparison experiments as we move ahead—keep ~everything the same except for one variable



Multiparton correlations

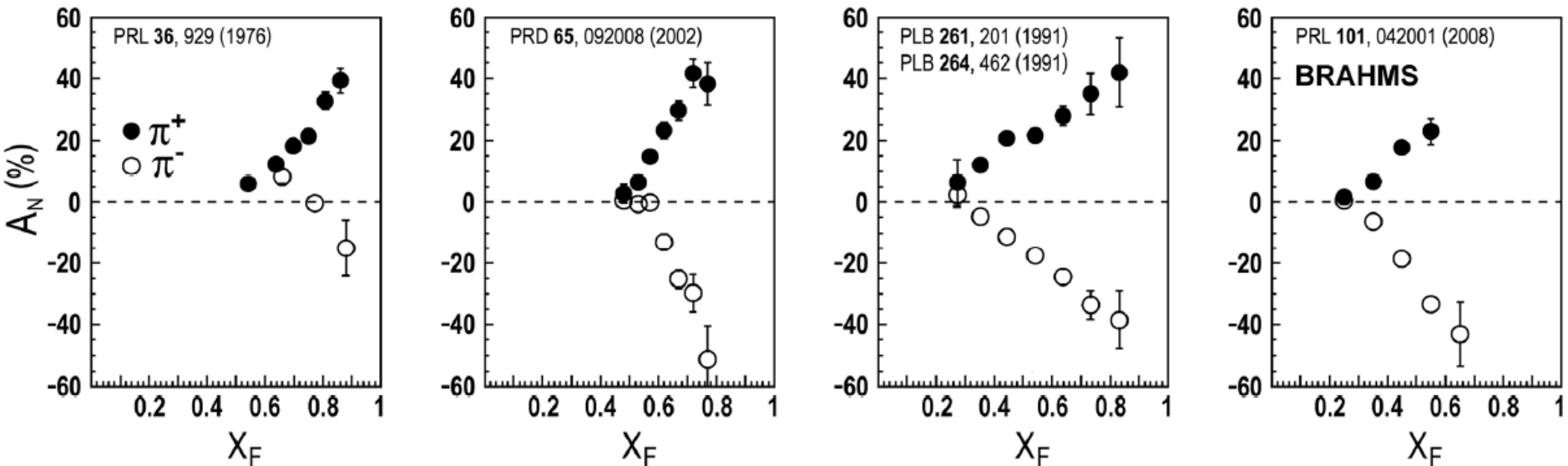

- Similar effects across energies \rightarrow Continuum between non-perturbative/non-partonic and perturbative/partonic descriptions of this non-perturbative structure??
- Extend our ideas about (single-parton) pdfs to correlation functions that can't be associated with a single parton . . .
- Talk by D. Sivers



Twist-3 multiparton correlations to interpret inclusive A_N data from RHIC

Talks by Y. Koike, D. Pitonyak

Making progress!

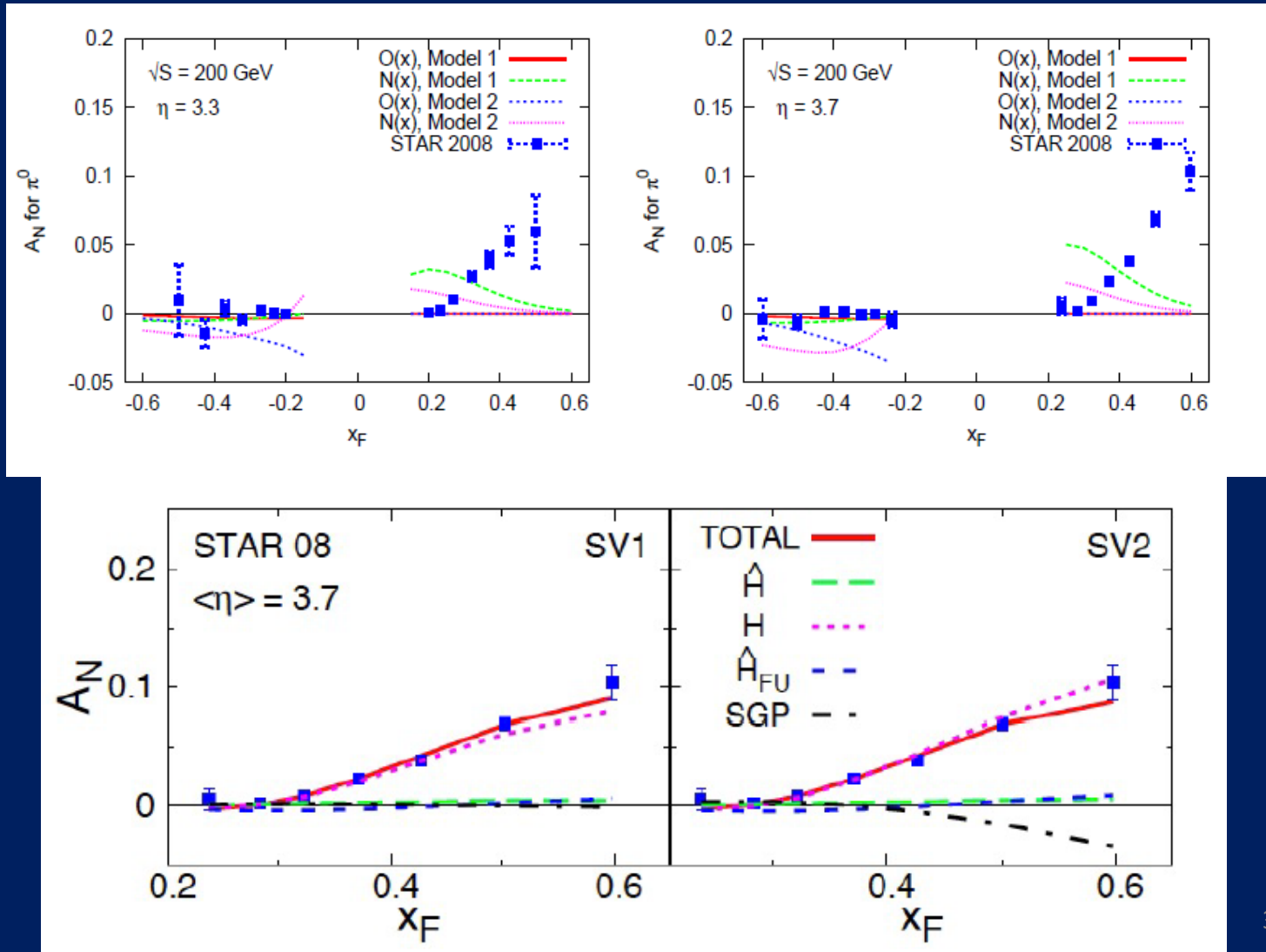

Inclusive hadron A_N in $e+p$

Phenomenology: twist-3

Gamberg, Kang, Metz, Pitonyak, AP (to appear)

$\hat{H}_{FU}^{h/q} = 0$. allows for a comparison with TMD results directly

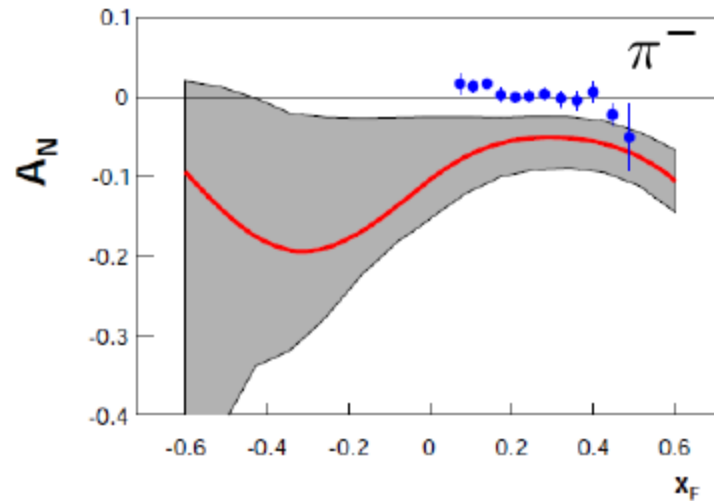
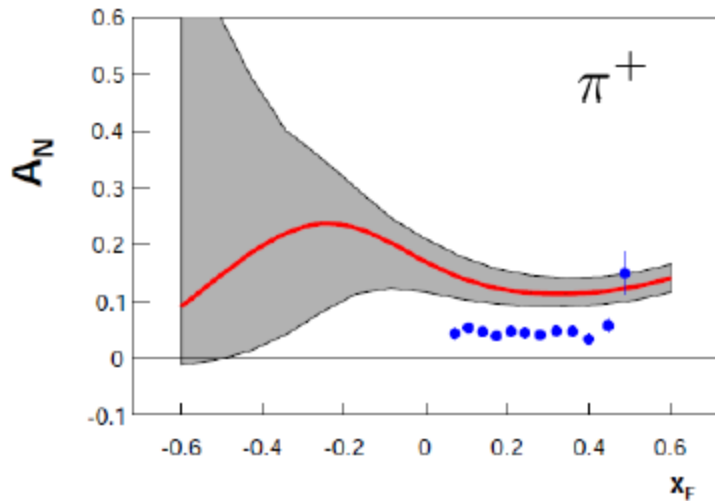

Collins contribution is not suppressed, Sivers dominates. $\pi^+\pi^-$ similar to TMD

Talk by A. Prokudin

Hadronization

- Not as far along as nucleon structure—less of a focus in earlier years
- Recent advances via
 - TMD FFs
 - Collinear twist-3 functions to describe hadronization
 - Dihadron (interference) FF
 - Hadronization from nuclei

Related talks by M. Radici, A. Kotzinian, I. Garzia, M. Grosse Perdekamp, F. Giordano, M. Contalbrigo, Y. Guan, O. Eyser, A. Vossen, + other p+p talks and all SIDIS talks . . .



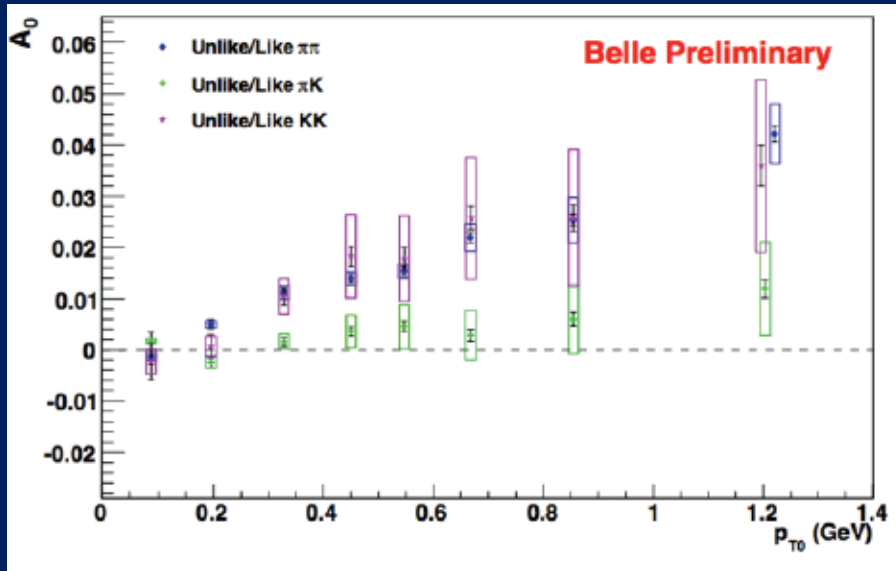

From talks by C. van Hulse, A. Vossen, C. Braun, F. Giordano

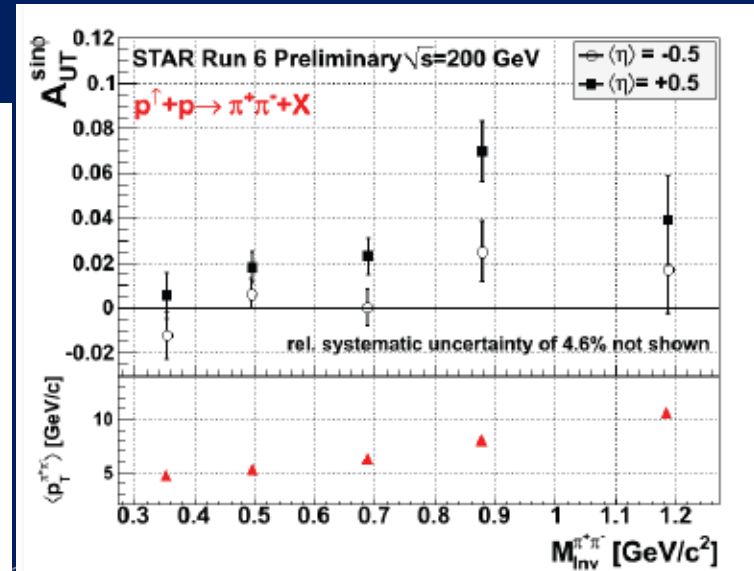
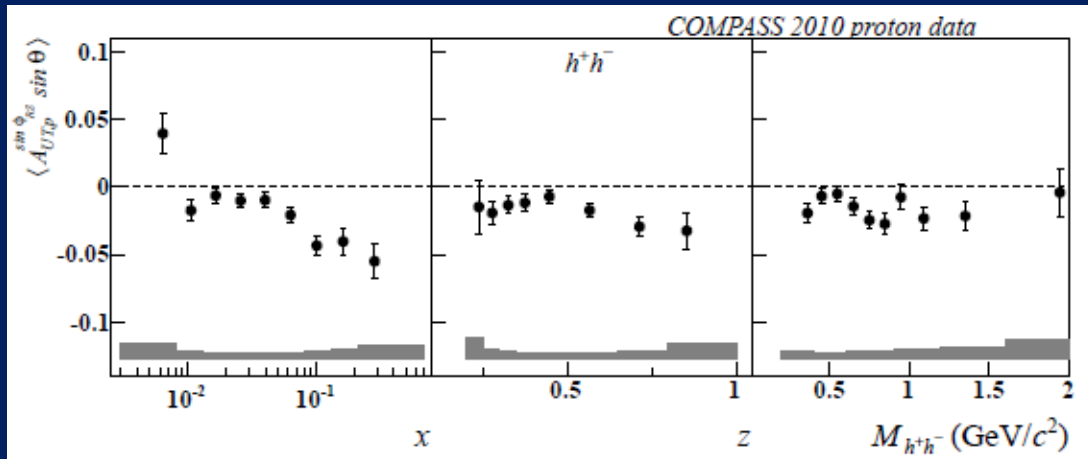
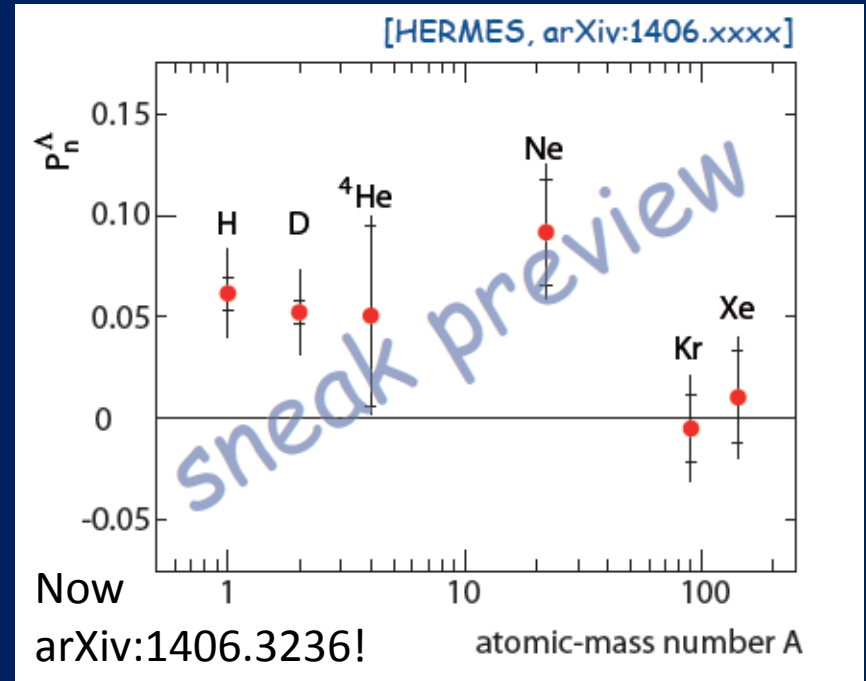

Identified hadron production: Ratios

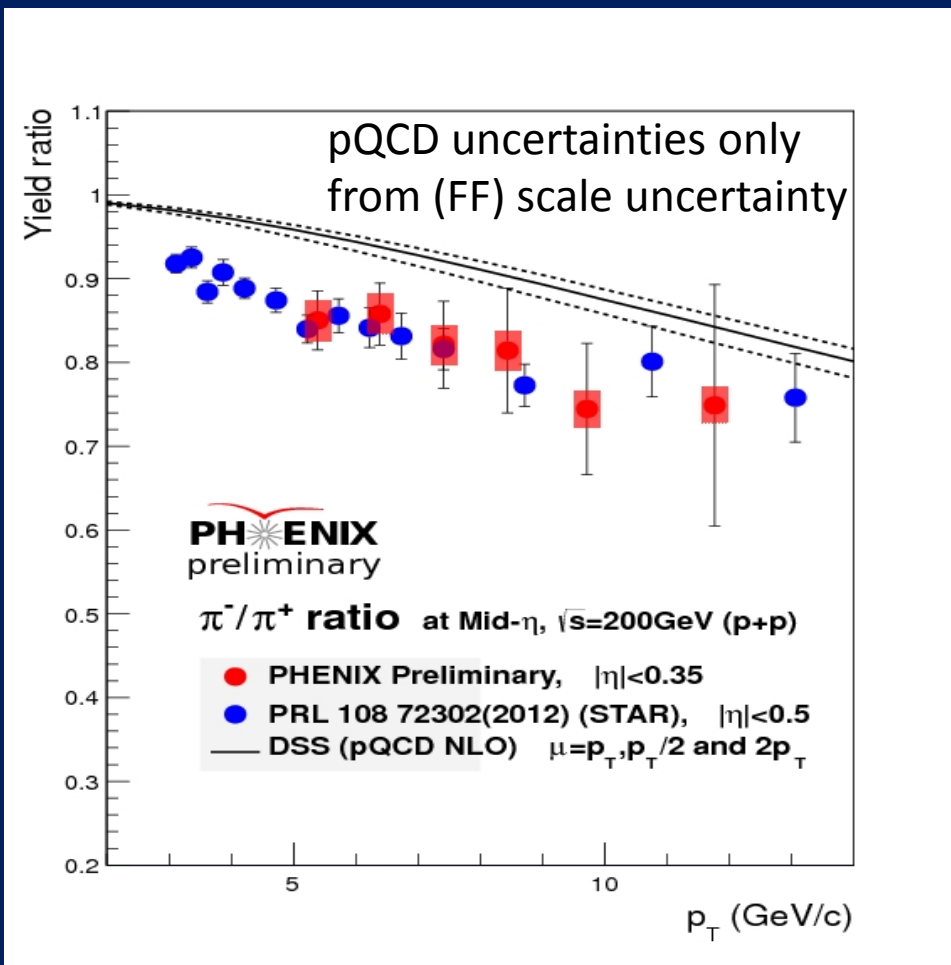

- Measured π^-/π^+ ratio significantly below NLO calculation in lower range of p_T
 - Data: Normalization uncertainties cancel *completely*
 - Calculation: Scale uncertainty greatly reduced
- PHENIX ratio consistent with STAR points, which lie many sigma below NLO calculation out to ~ 10 GeV
- *More powerful to fit ratios directly in the future where available*



Identified hadron production: Ratios

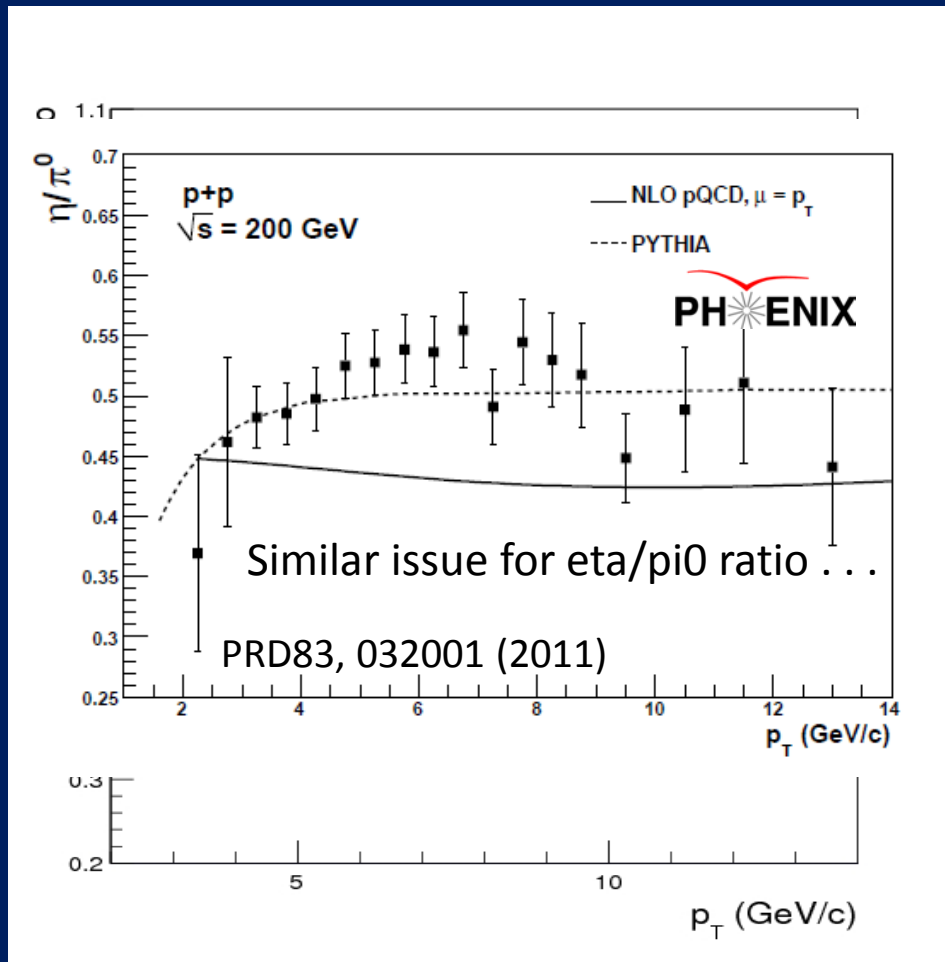

- Measured π^-/π^+ ratio significantly below NLO calculation in lower range of p_T
 - Data: Normalization uncertainties cancel *completely*
 - Calculation: Scale uncertainty greatly reduced
- PHENIX ratio consistent with STAR points, which lie many sigma below NLO calculation out to $\sim 10 \text{ GeV}$
- *More powerful to fit ratios directly in the future where available*

Eventually even more global global fits?

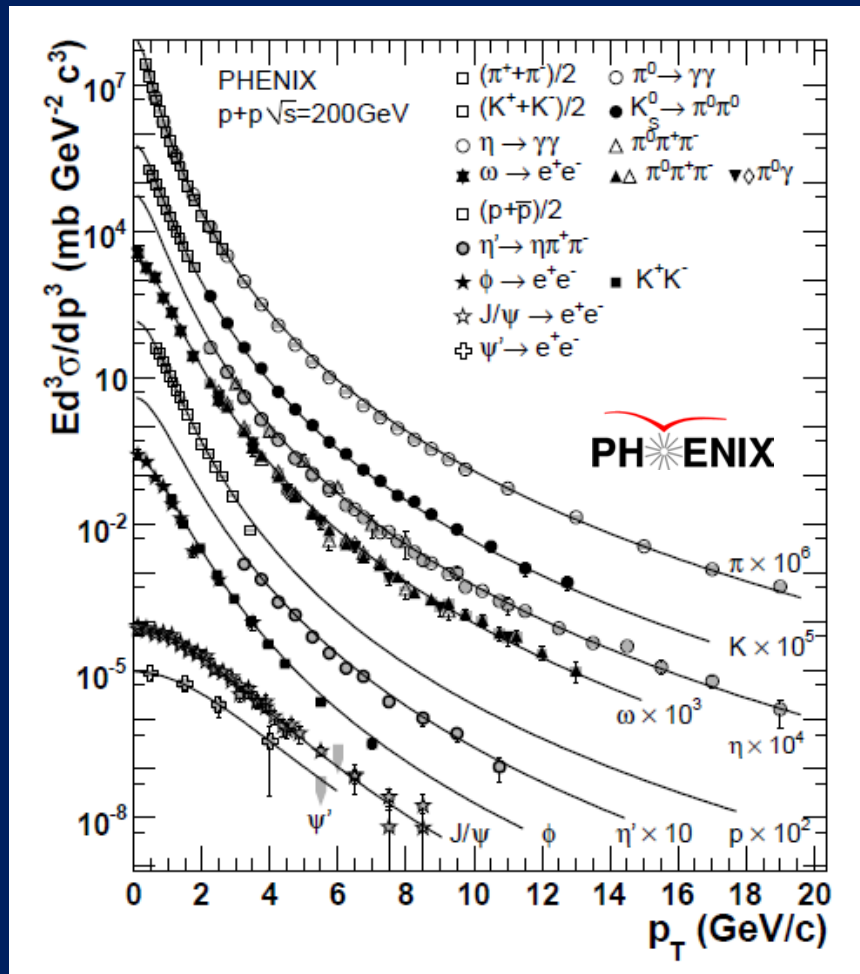

- Perform FF parameterizations for even more particles simultaneously?
 - Will constrain relative normalizations well
- Ultimate goal: Measure jet and all particles within it!
- Fit pdfs and FFs simultaneously . . .

Mechanisms of hadronization other than “fragmentation”:

Baryon enhancement in $d+Au$ and $Au+Au$

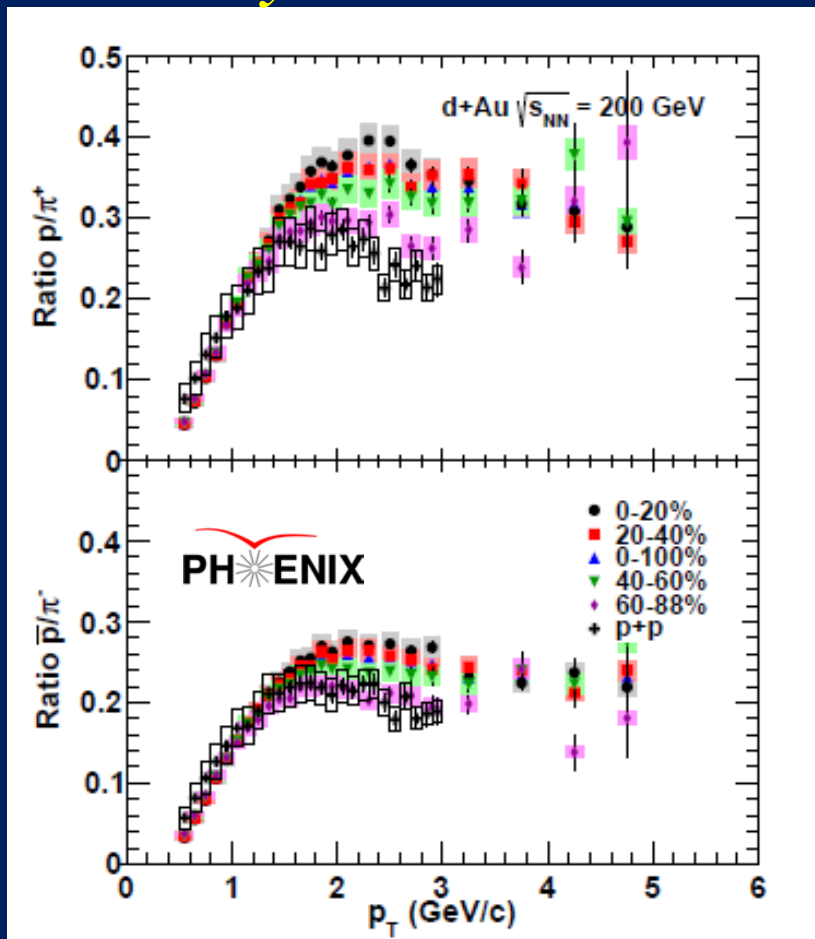

- Precision $d+Au$ data for identified charged hadrons in bins of centrality
- New hadron production mechanism enabled by presence of additional partons/nucleons
 - Parton recombination?
- Strong centrality dependence despite small range of # participants
- Well-known centrality-dependent baryon enhancement in $Au+Au$
 - Previously explained by recombination of thermalized partons

PRC88, 024906 (2013)



Comparing central d+Au with peripheral Au+Au

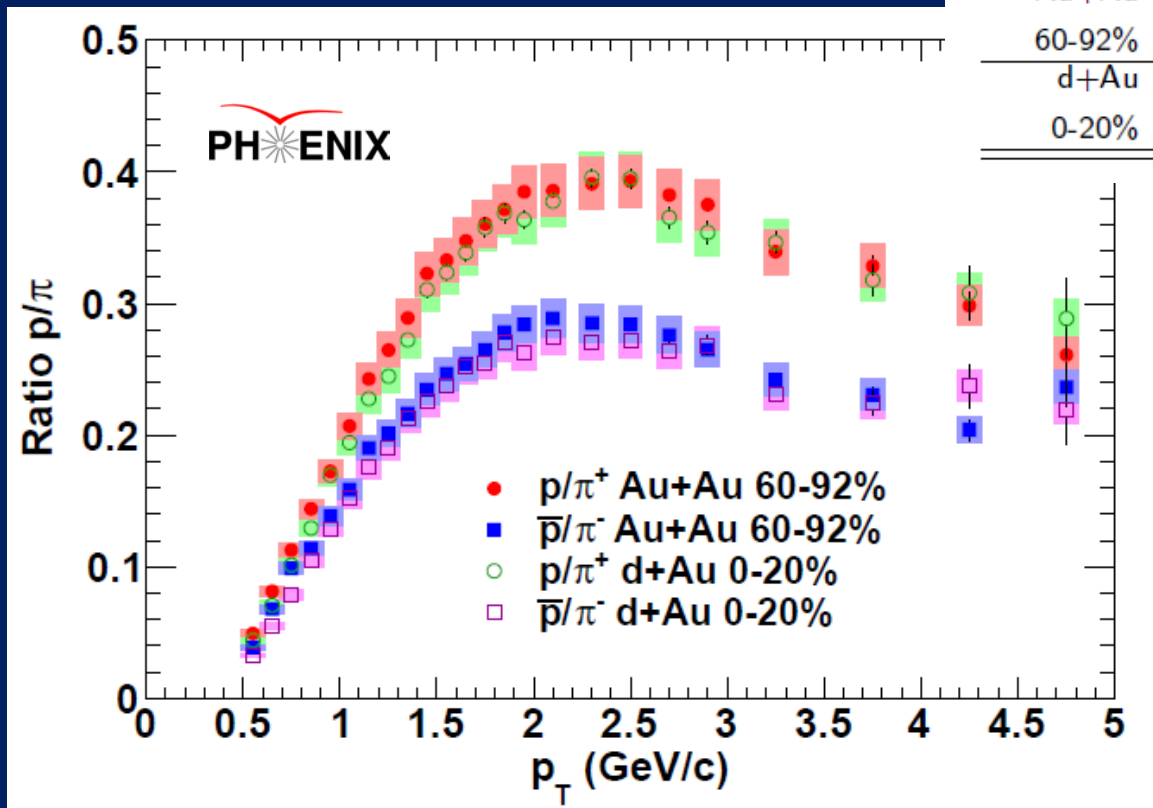

Centrality	$\langle N_{coll} \rangle$	$\langle N_{part} \rangle$
Au+Au		
60-92%	14.8 ± 3.0	14.7 ± 2.9
d+Au		
0-20%	15.1 ± 1.0	15.3 ± 0.8

Both shape and magnitude identical!

Suggests common mechanism(s) for baryon production in the two systems—partons nearby in phase space bind? Don't need thermalized medium

PRC88, 024906 (2013)



Bound states of hadronic bound states: Creating nuclei!

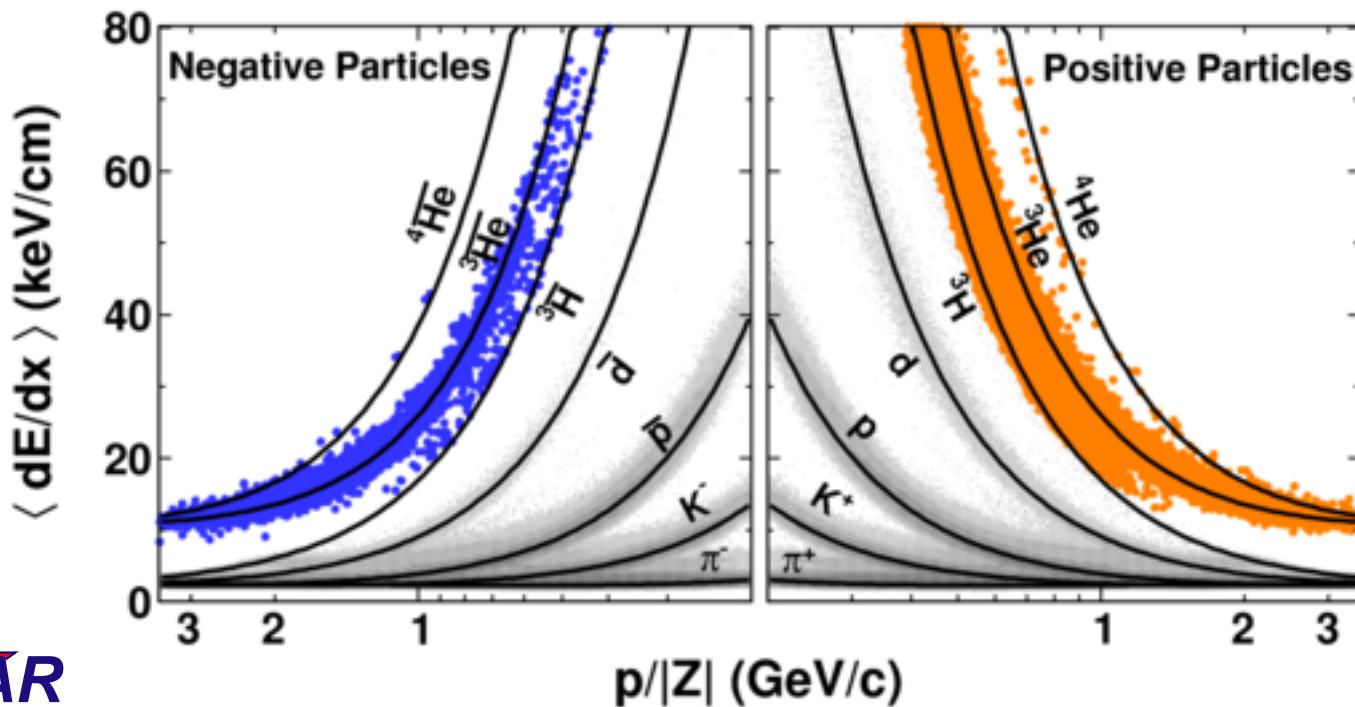

Nature 473, 353 (2011)



A cyclical process

“Starting out, you take the simplest ansatz.”

– P. Kroll

“We must not give up our intuition.”

– M. Anselmino

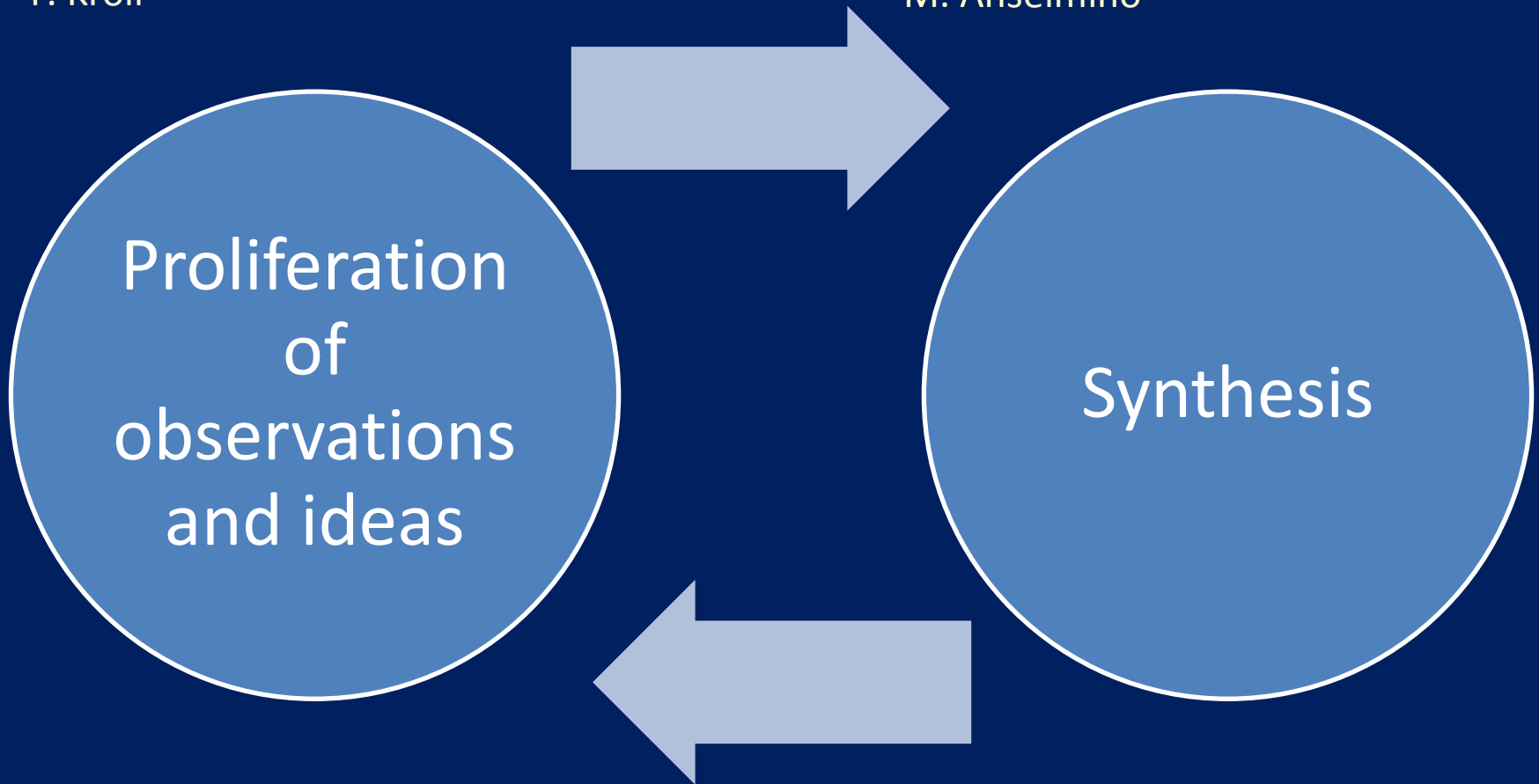

Increasing connections among (historically disparate) areas of QCD

As we advance, we're building more connections among the various areas of QCD

- TMD and HEP theory communities – SCET, Q_T resummation
- Jet substructure in HEP and TMD, higher-twist, or dihadron FFs
- TMDs at the LHC – M. Schlegel, J.P. Lansberg talks
- Multiparton Interactions (MPI) in HEP community and multiparton correlations
- Nucleon structure, HEP, and heavy ion low-x communities – gluon saturation
- Heavy ion and nucleon structure communities - Nuclear pdfs, mainly “vanilla” collinear so far, but starting to consider TMD – E. Pace talk
- Heavy ion and neutron star communities – dense, hot vs. dense, cold corners of QCD phase diagram



Increasing connections among (historically disparate) areas of QCD

- Heavy ion and hadronization - “fragmentation” vs. nearby partons in phase space; parton energy loss in hot or cold nuclear matter (M. Contalbrigo talk)
- Heavy ion (quark-gluon plasma) physics and low-energy nuclear reactions; cosmology
 - “Little Bang Nucleosynthesis”
- Diffractive physics in heavy ion collisions and GPDs; Impact-parameter-dependent nuclear distributions and collision geometry in heavy ion physics; GPDs and proton radius puzzle via form factors
- OAM (E. Leader and M. Burkardt talks) and GPDs, TMDs (A. Mukherjee talk)
- Hadron spectroscopy and OAM – D. Sivers talk
- Hadron spectroscopy and hadronization/FFs—B factories as common facilities
- Hadronic vs. partonic dof in JLab program and moving beyond single-parton functions in hadrons



We should make every effort to strengthen these links

- E.g. stronger links to mainstream HEP experimental community
 - There's lots of QCD physics to be done in p+p collisions at the LHC!
 - Share more Monte Carlo tools? (G. Schnell, H. Avakian talks)
 - 125 GeV Higgs: e+e- Higgs factory would be great to study FFs at a complementary scale to current B factories!
“Unpolarized reactions are the basic tool linking many different fields of investigation.” – M. Contalbrigo



Final remarks

- Early years of *quantitative* basic research in QCD
- Proton has key role to play as lightest stable QCD bound state (and component of everyday matter!)
- Electron-Ion Collider: Facility to bring the era of quantitative QCD to maturity . . . BUT—
- Measurements in complementary systems important!

- More connections starting to be developed among various QCD subfields
- *Taking small, initial steps along the path toward “grand unification” of QCD across different scales, from partons to neutron stars . . .*





Thanks for making this such a nice community . . .



Extra



Mapping out the proton

What does the proton look like in terms of the quarks and gluons inside it?

- *Position*
- *Momentum*
- *Spin*
- *Flavor*
- *Color*

Theoretical and experimental concepts to describe and access position only born in mid-1990s. Pioneering measurements over past decade.

Polarized protons first studied in 1980s. How angular momentum of quarks and gluons add up still not well

Early measurements of flavor distributions in valence region. Flavor structure at lower momentum fractions

Accounted for by theorists from beginning of QCD, but more detailed, potentially observable effects of color have come to forefront in last couple years . . .



EIC

- A facility to bring this new era of quantitative QCD to maturity!
- *How can QCD matter be described in terms of the quark and gluon d.o.f. in the field theory?*
- *How does a colored quark or gluon become a colorless object?*

- Study in detail

- “Simple” QCD bound states
- Collections of QCD bound states: Nuclei
- Hadronization



Midrapidity charge-separated hadrons in 62.4 GeV p+p: Reining in scale uncertainties with NLL resummation

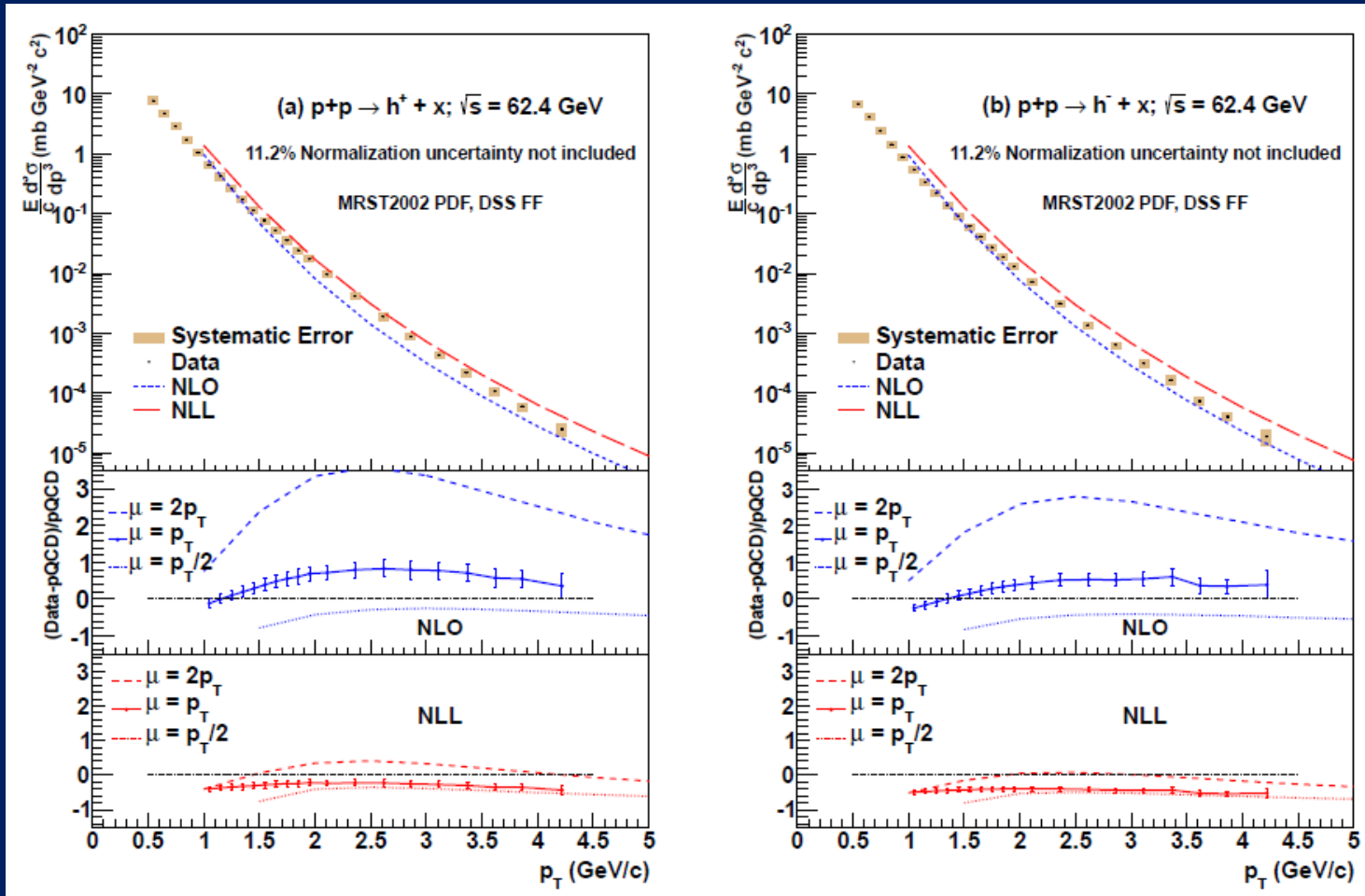

Forward charged π and K production at 62.4 GeV

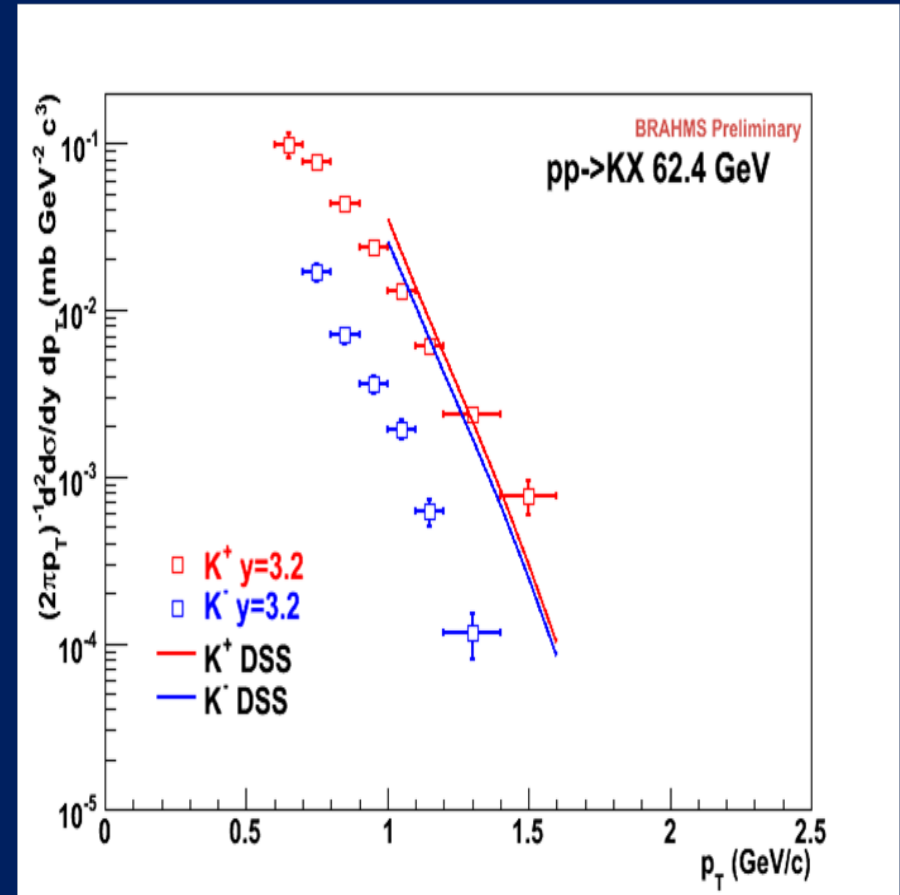
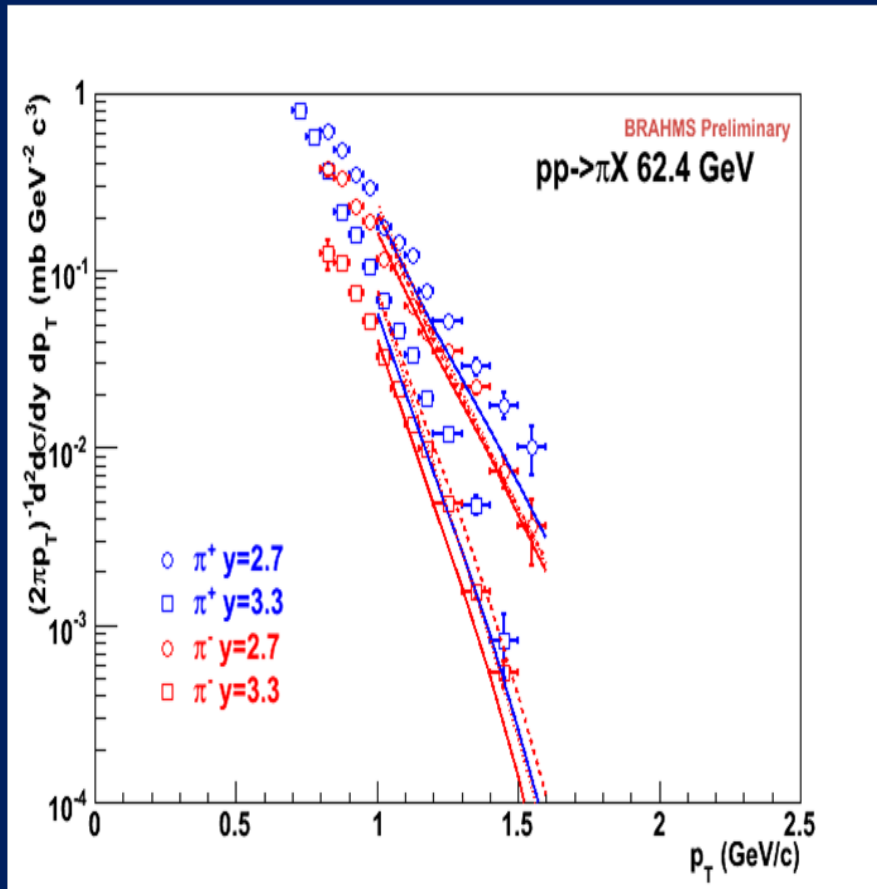

Scale uncertainty remains large for single-particle cross sections even for $\sqrt{s} = 500 \text{ GeV}$ and p_T up to 30 GeV

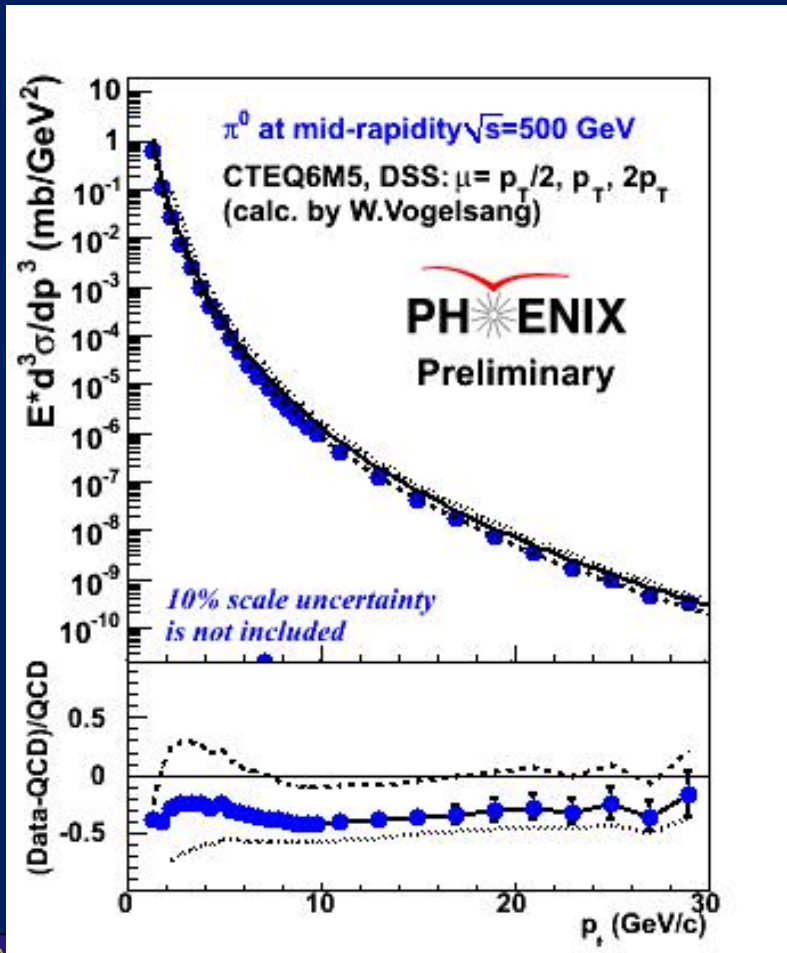

- “Good” agreement with NLO, but still only within $\sim 20\text{-}50\%$
- Measured π^-/π^+ ratio at 200 GeV within $\sim 15\%$ of NLO calculation, but less “good” because of greatly reduced scale uncertainties
 - Evidently other uncertainties relevant
- What are the most appropriate uncertainties to use in each case?

NNPDF dbar/ubar

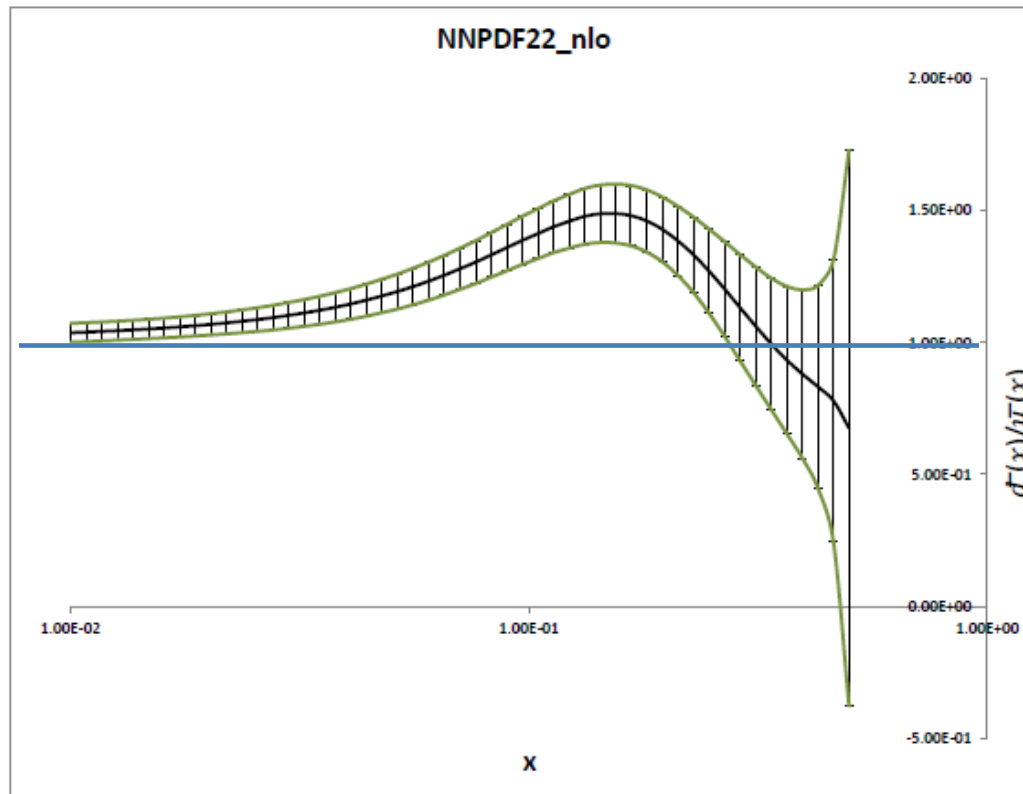

Fermilab E1039

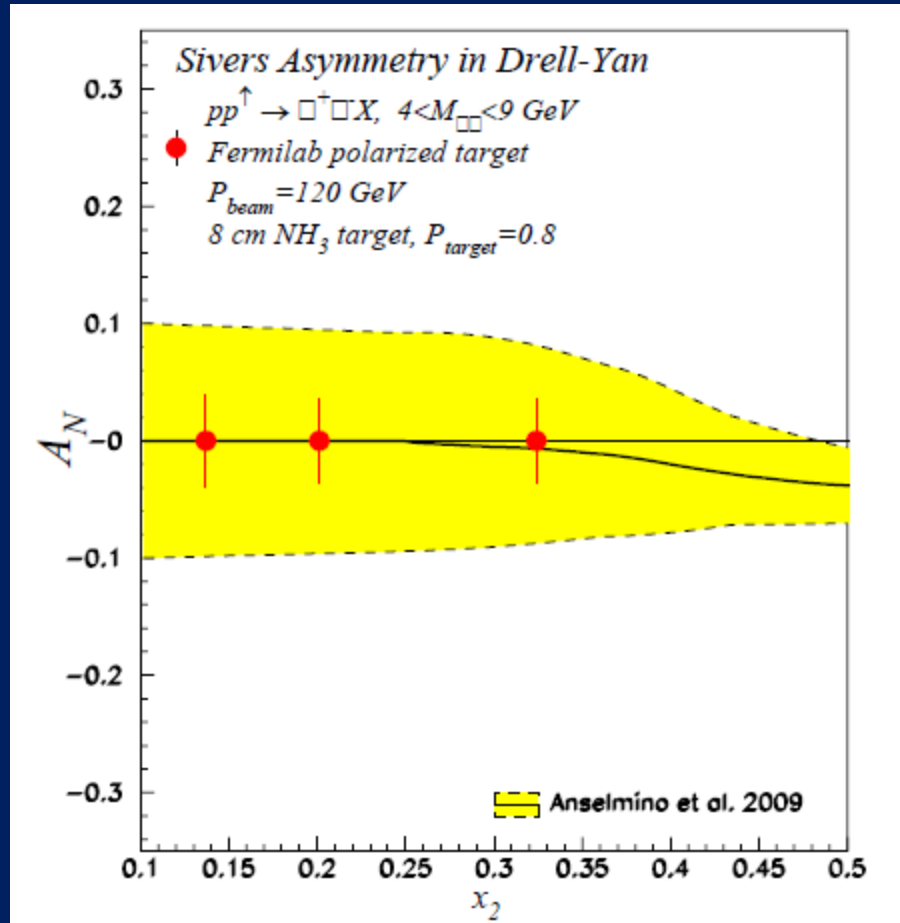

Eta vs. kaon A_N ?

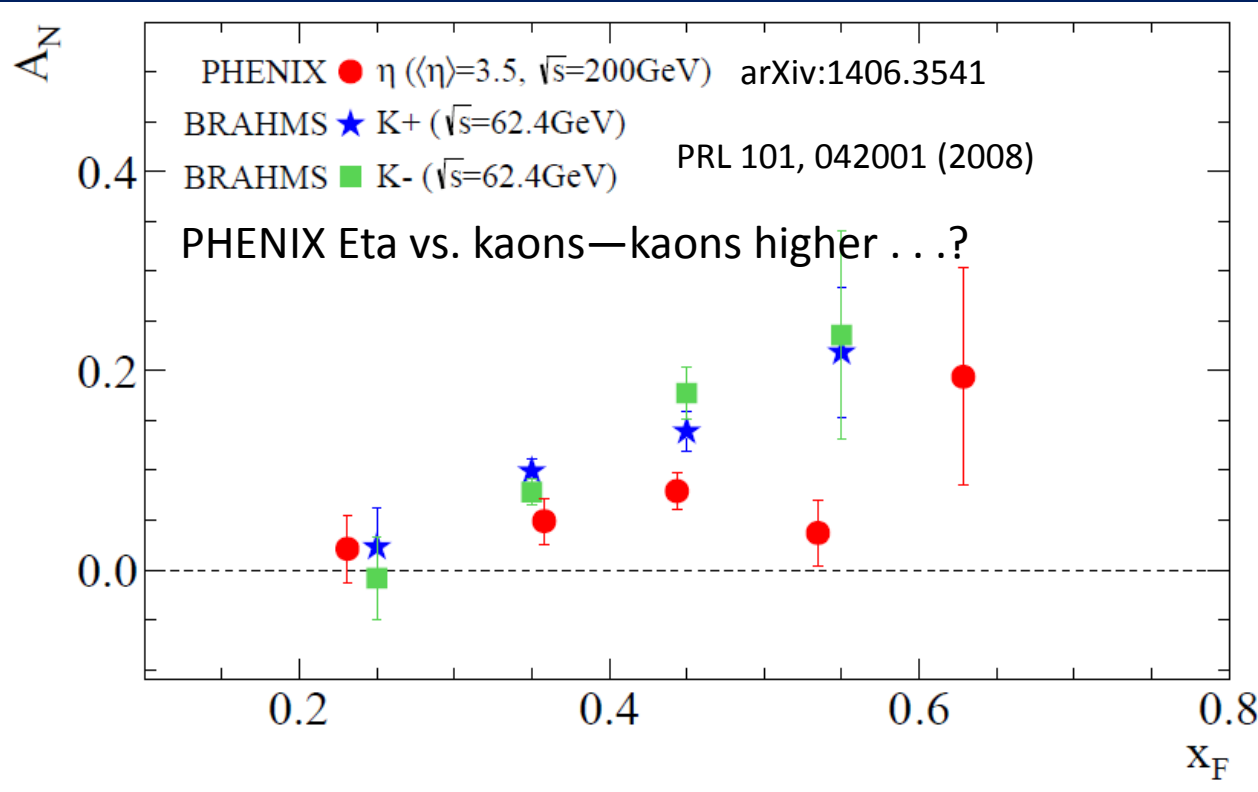

Kaons higher, including K^- , although not apples-to-apples.



Hadronization: A lot to learn, from a variety of collision systems

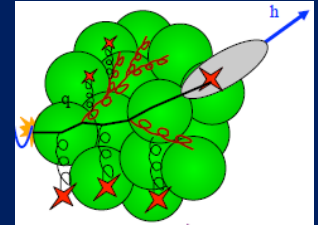

What are the ways in which partons can turn into hadrons?

- Spin-momentum correlations in hadronization?
 - Correlations now measured definitively in e^+e^- (BELLE, BABAR)
- Gluons vs. quarks?
 - Gluon vs. quark jets a hot topic in the LHC $p+p$ program right now
 - Go back to clean e^+e^- with new jet analysis techniques in hand?
- In “vacuum” vs. cold nuclear matter vs. hot + dense QCD matter?
 - Use path lengths through nuclei to benchmark hadronization times $\rightarrow e+A$
- Hadronization via “fragmentation” (what does that really mean?), “freeze-out,” “recombination,” . . . ?
 - Soft hadron production from thermalized quark-gluon plasma—different mechanism than hadronization from hard-scattered q or g ?
- Light atomic nuclei and antinuclei also produced in heavy ion collisions at RHIC!
 - How are such “compound” QCD systems formed from partons? Cosmological implications??
- ...

Hadronization: A lot to learn, from a variety of collision systems

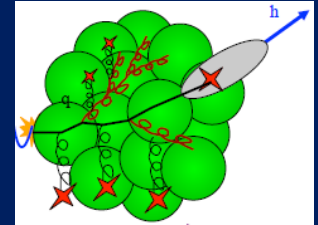

What are the ways in which partons can turn into hadrons?

- Spin-momentum correlations in hadronization?
 - Correlations now measured definitively in e^+e^- (BELLE, BABAR)
- Gluons vs. quarks?

- In my opinion, hadronization has been a largely neglected area over the past decades of QCD—lots of progress to look forward to in upcoming years, with e^+A , $p+p$, and $A+A$ all playing a role along with e^+e^- !
 - Soft hadron production from thermalized quark-gluon plasma—different mechanism than hadronization from hard-scattered q or g ?
- Light atomic nuclei and antinuclei also produced in heavy ion collisions at RHIC!
 - How are such “compound” QCD systems formed from partons? Cosmological implications??
- ...

Comparing central $d+Au$ with peripheral $Au+Au$

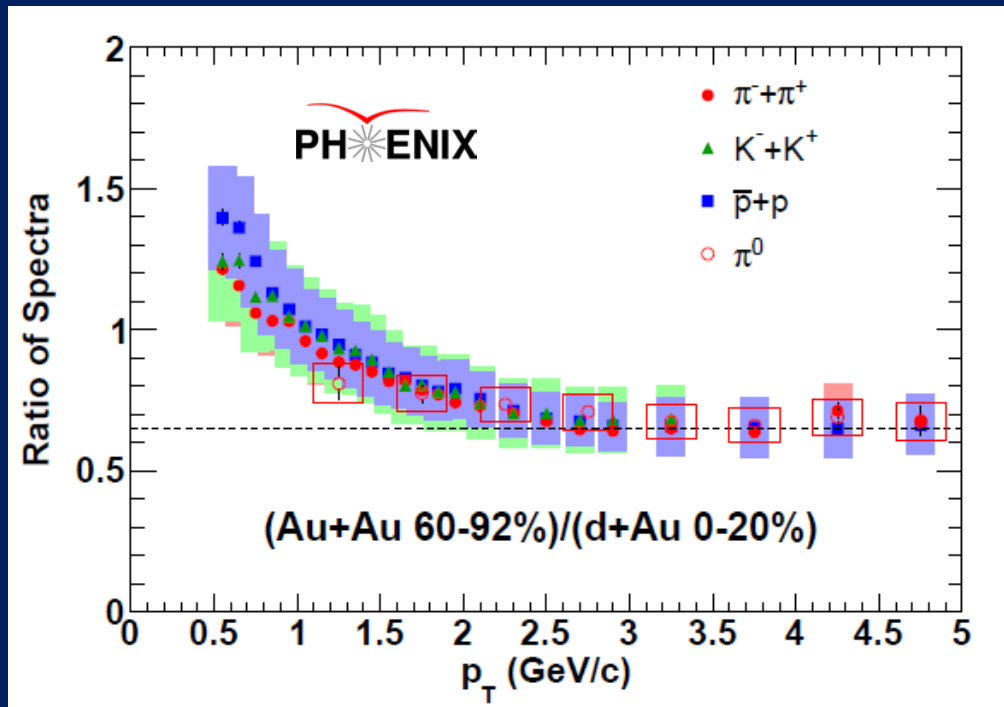

PRC88, 024906 (2013) *No scaling applied*

- Direct ratio of spectra is flat above 2.5 GeV and species independent
 - Baryon enhancement is *quantitatively* the same
 - Ratio significantly less than unity—suggests energy loss for all species in peripheral Au+Au

Enhancement of strange meson production in central Au+Au

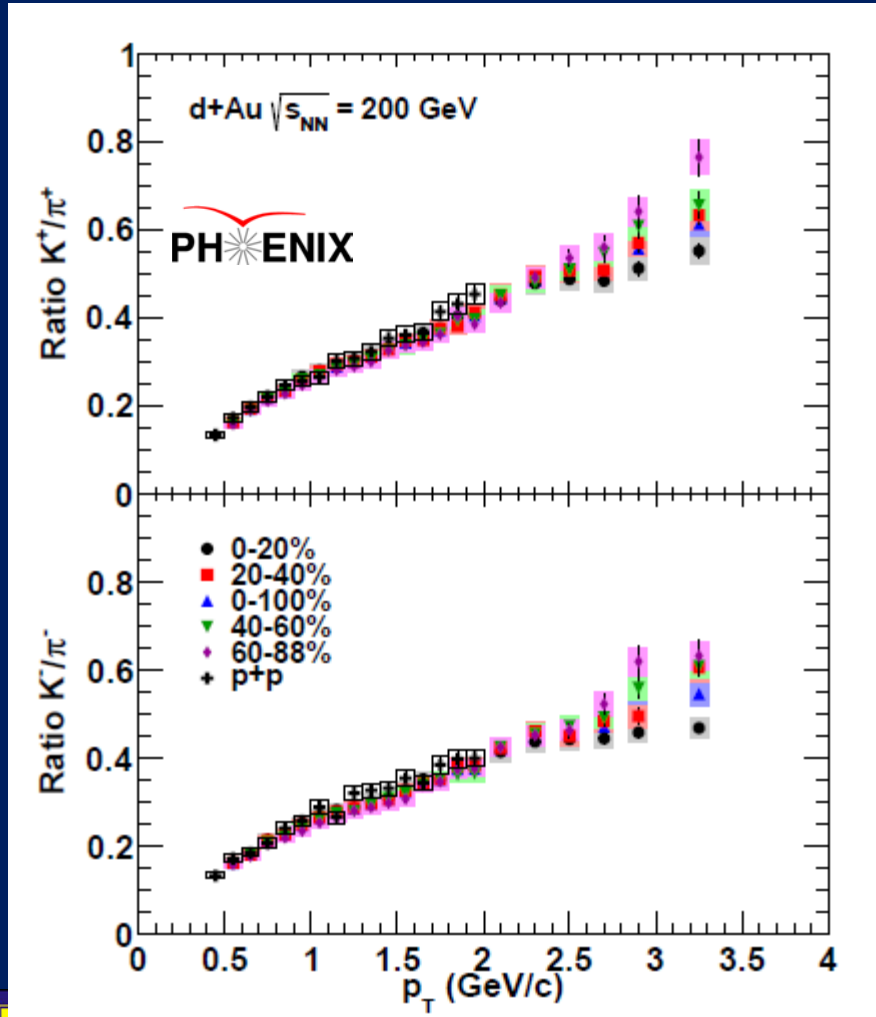

- K/π ratio higher in more central Au+Au than p+p, increases with centrality
- K/π ratio in d+Au same as p+p for all centralities

Strange meson production in Au+Au

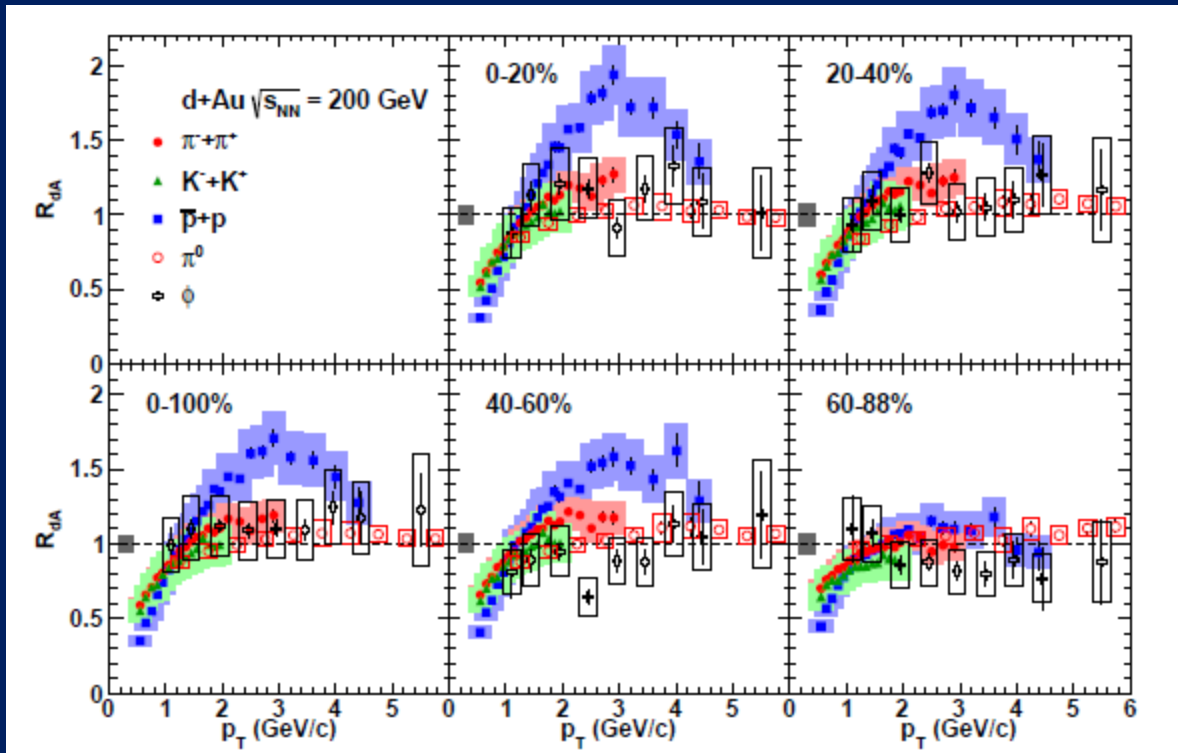

- In Au+Au, kaon and pion most separated in central events
- Phi seems to stay between kaon and proton
- In d+Au, charged pions and kaons consistent with each other, and phi exhibits minimal modification
- Suggests additional strange meson production mechanism in central Au+Au compared to d+Au or p+p

Insight from New Measurements

- New information on proton structure
 - $G_E(Q^2) \neq G_M(Q^2) \rightarrow$ different charge, magnetization distributions
 - Connection to GPDs: spin-space-momentum correlations

Model-dependent extraction of charge, magnetization distribution of proton:

J. Kelly, Phys. Rev. C 66, 065203 (2002)

A. Belitsky, X. Ji, F. Yuan, PRD69:074014 (2004)

G. Miller, PRC 68:022201 (2003)

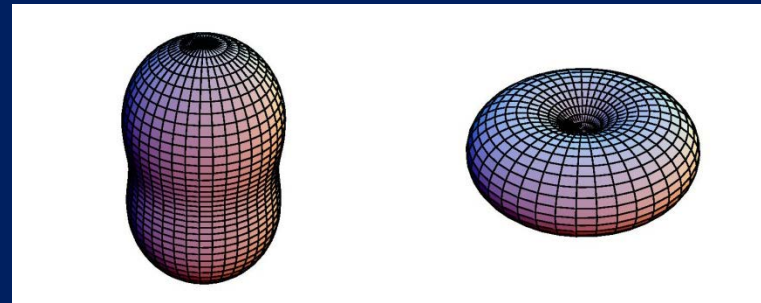
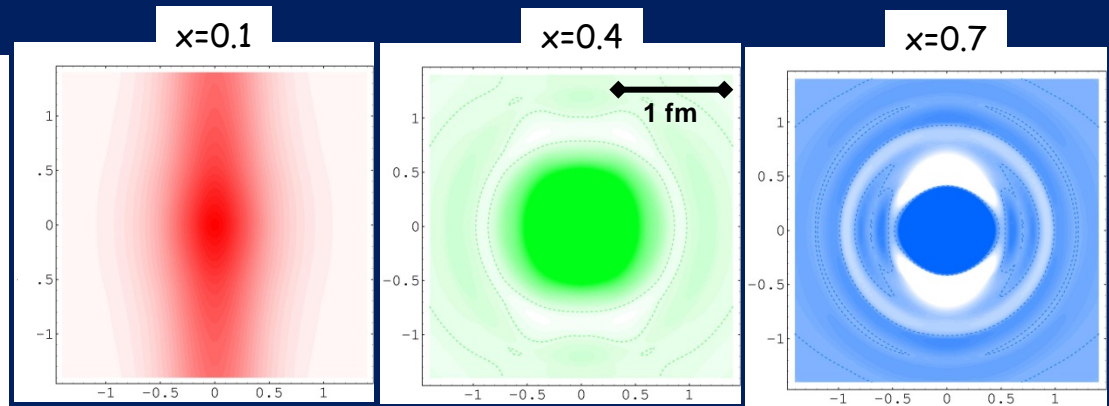
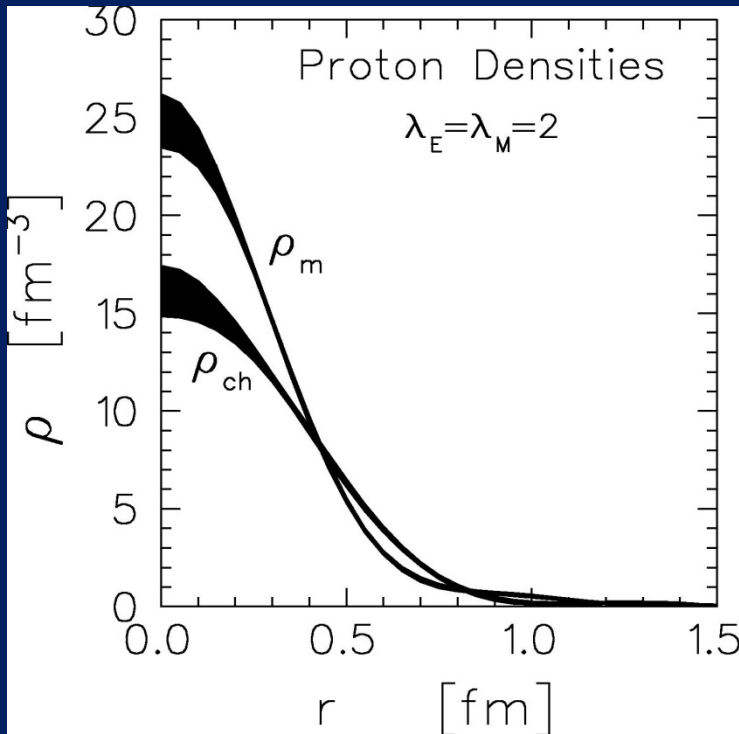

Slide courtesy J. Arrington

Eta mesons in 200 GeV p+p

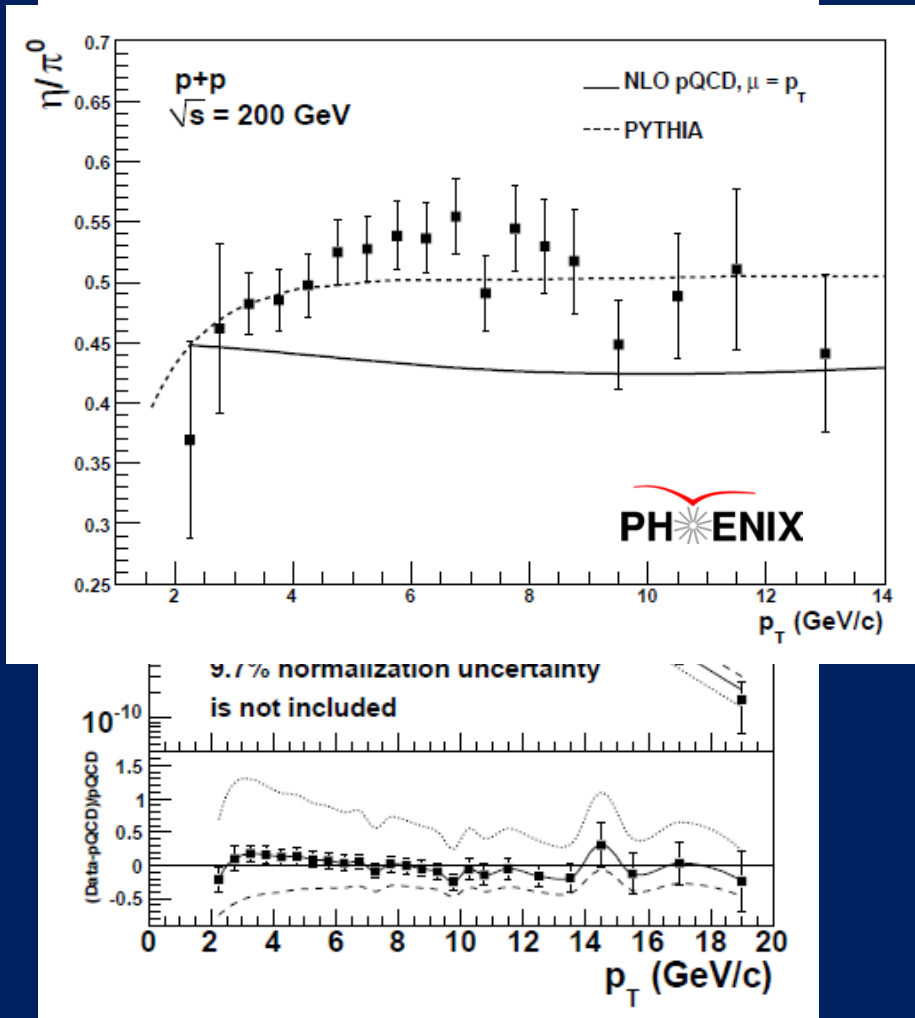

- Cross section data used in FF fit
- NLO calculation for η/π^0 ratio ~15% too low (no uncertainties shown)
- In this particular case, PHENIX eta data and (earlier but consistent) π^0 data were used in the respective FF fits, but in π^0 fit, PHENIX data normalization scaled within uncertainty in one direction, and in eta fit, scaled in other direction
- Fitting ratio directly would automatically take into account the 100% correlated normalization uncertainties

PRD83, 032001 (2011)



ALICE η/π^0 ratio, $p+p$ at 7 TeV

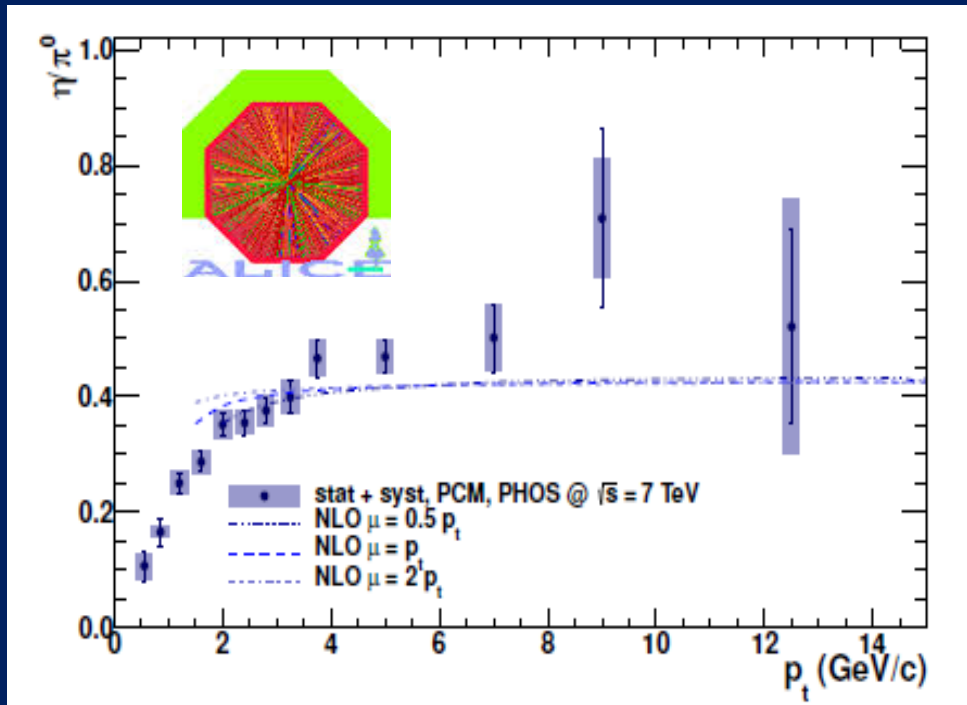

PLB717, 152 (2012)

- Same p_T range as PHENIX data
- Calculated ratio again below data
- Scale uncertainty on NLO calculation shown

Density dependence of EMC effect?

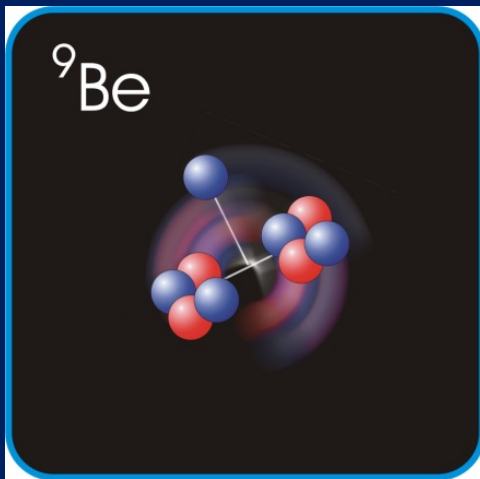
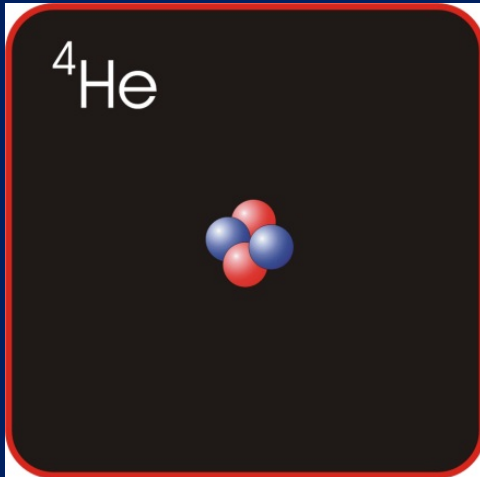

Credit: P. Mueller

J.Seely, et al., PRL103, 202301 (2009)

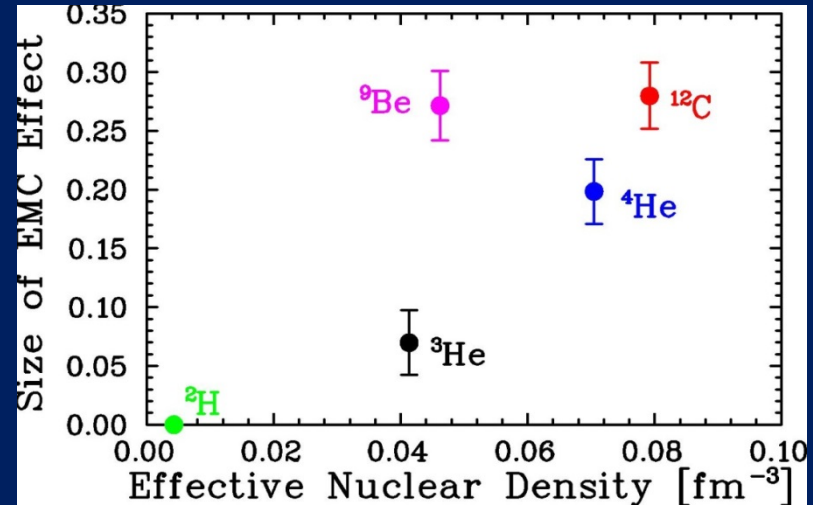

N. Fomin, et al., PRL108 (2012) 092052

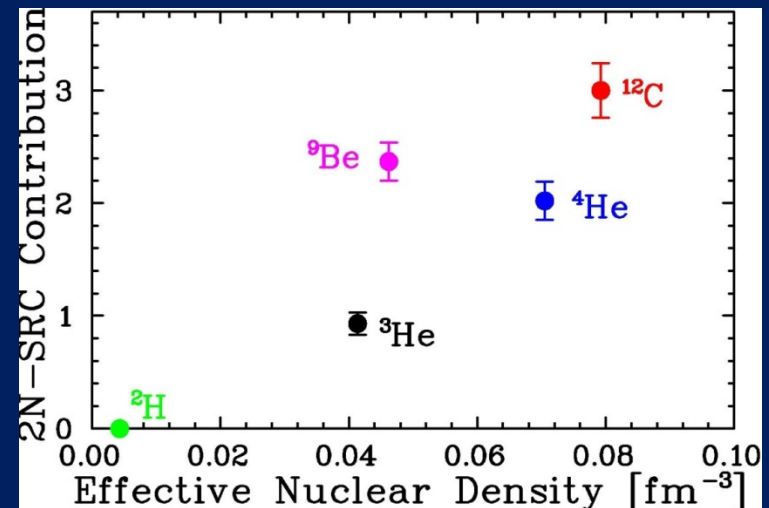

Connection between short-range correlations and EMC effect: Importance of two-body effects??

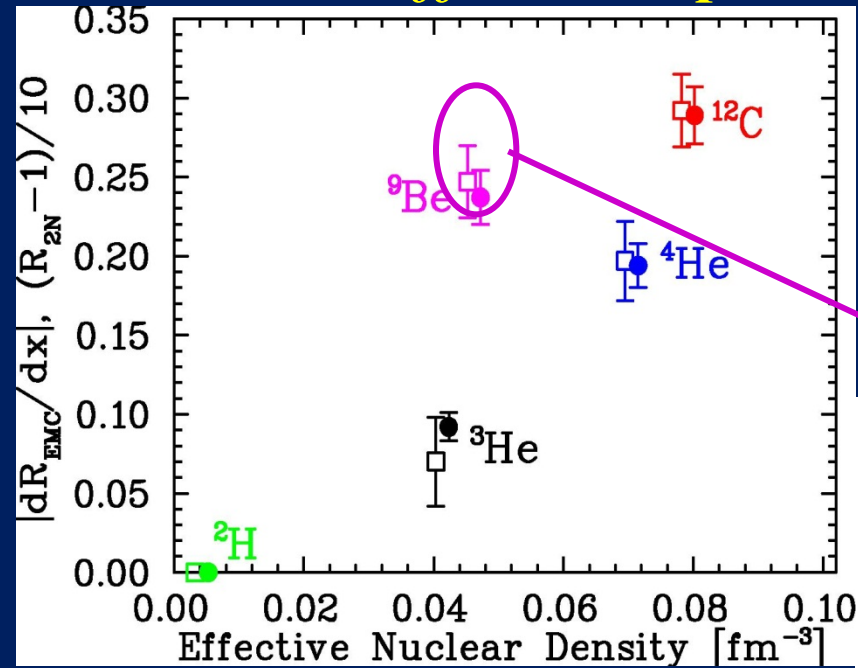

5-10% suppression in all nucleons?

25-50% change in 20% of nucleons (high-momentum)?

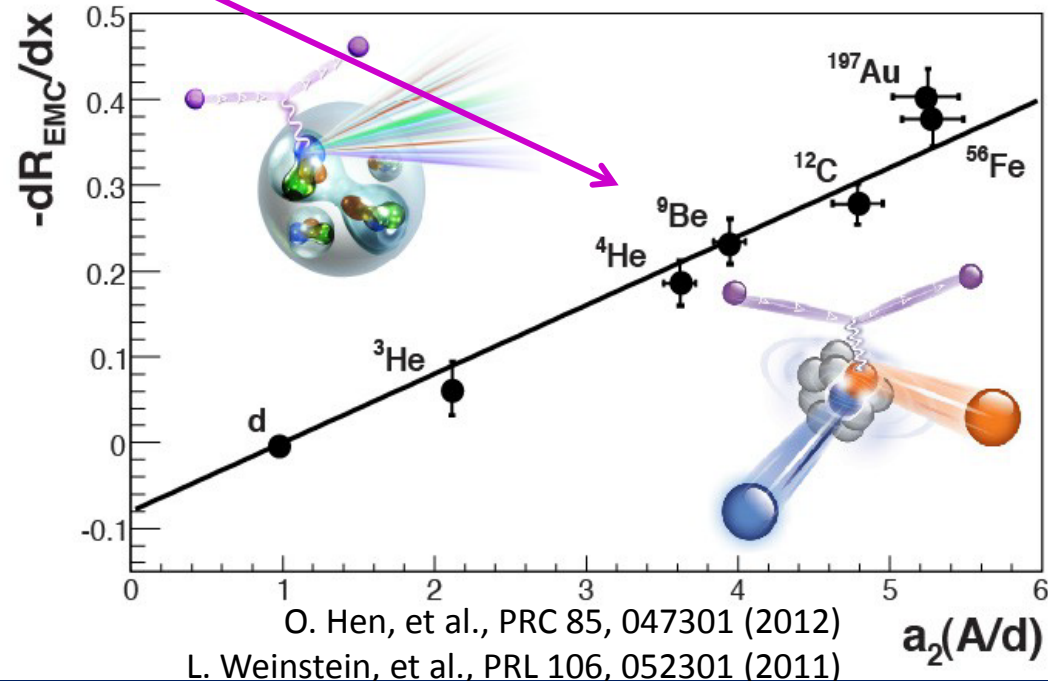

J. Seely, et al., PRL103, 202301 (2009)

N. Fomin, et al., PRL 108, 092052 (2012)

JA, A. Daniel, D. Day, N. Fomin, D. Gaskell,
P. Solvignon, PRC 86 (2012) 065204

O. Hen, et al., PRC 85, 047301 (2012)

L. Weinstein, et al., PRL 106, 052301 (2011)



p+p cross sections: Charged pions, 200 GeV

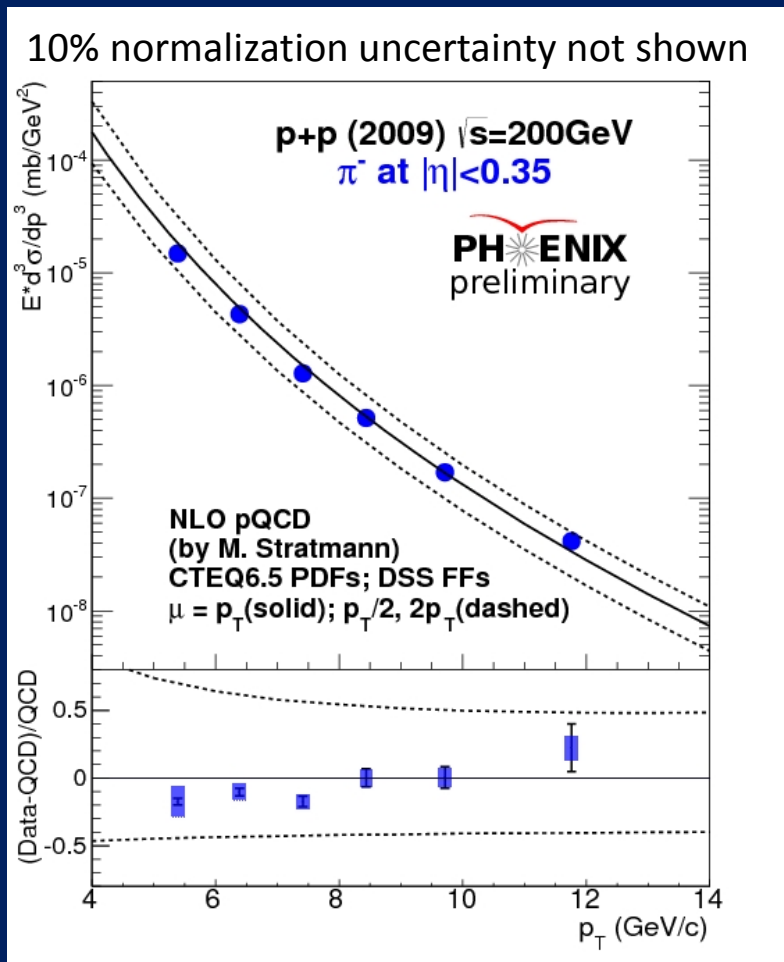

- Charge-separated pion cross sections $5 < p_T < 14$ GeV
- Consistent with NLO pQCD calculations using DSS FFs, within (large) scale uncertainty
- Data themselves have 10% normalization uncertainty
- Use as input in future fits—how best to incorporate?

p+p cross sections: Charged pions, 200 GeV

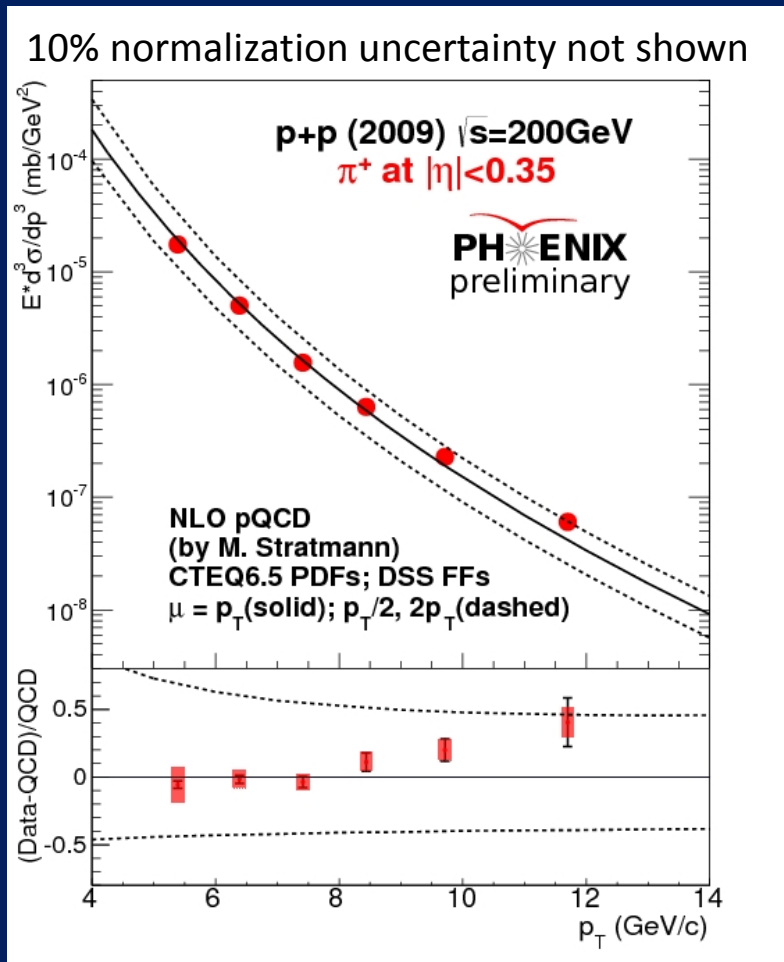

- Charge-separated pion cross sections $5 < p_T < 14$ GeV
- Consistent with NLO pQCD calculations using DSS FFs, within (large) scale uncertainty
- Data themselves have 10% normalization uncertainty
- Use as input in future fits—how best to incorporate?

★ 3-gluon contribution to $p^\dagger p \rightarrow \pi X$

Ex. Purely gluonic contributions

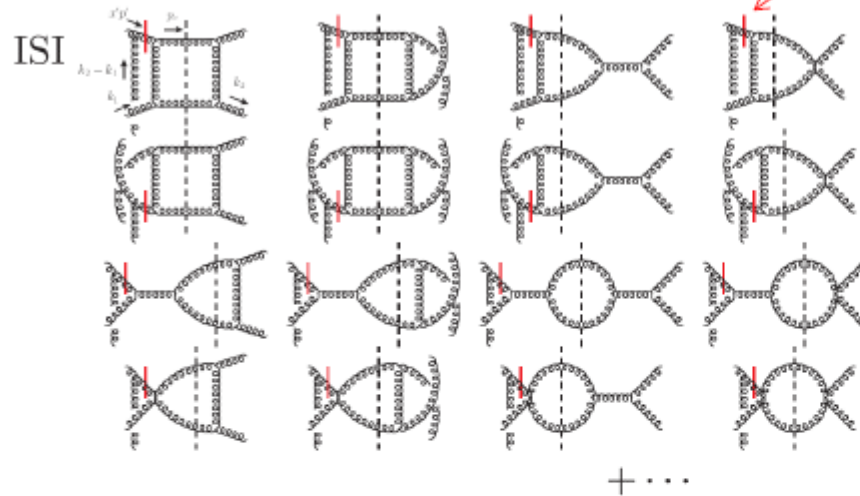

Cross section can be written in terms of $N(x, x)$, $N(x, 0)$, $O(x, x)$ and $O(x, 0)$.



Further simplification:

They appear in the combination of

$$O(x) \equiv O(x, x) + O(x, 0)$$

$$N(x) \equiv N(x, x) - N(x, 0).$$

This is not the case for SIDIS and Drell-Yan with large Q^2 .

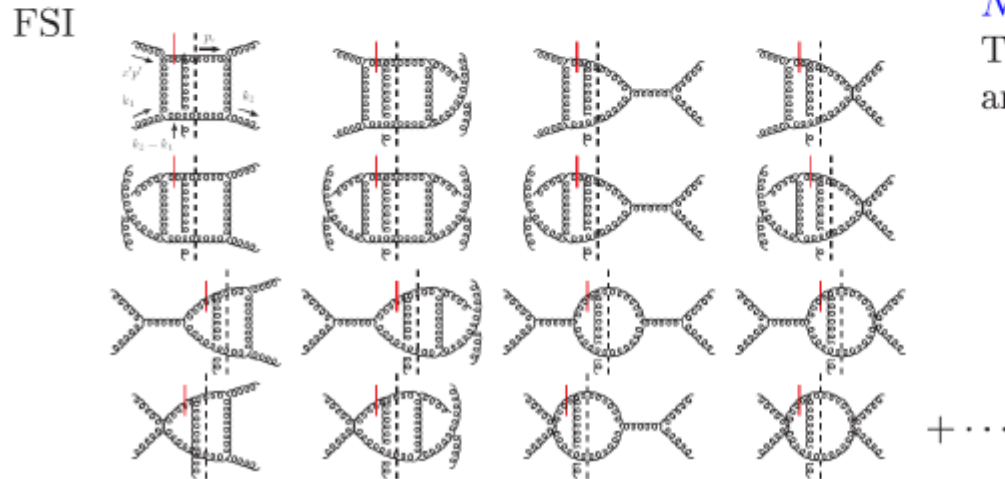

• Numerically, this is the most important channel for A_N at $x_F > 0$.

Mechanisms of hadronization other than “fragmentation”:

Baryon enhancement in $d+Au$ and $Au+Au$

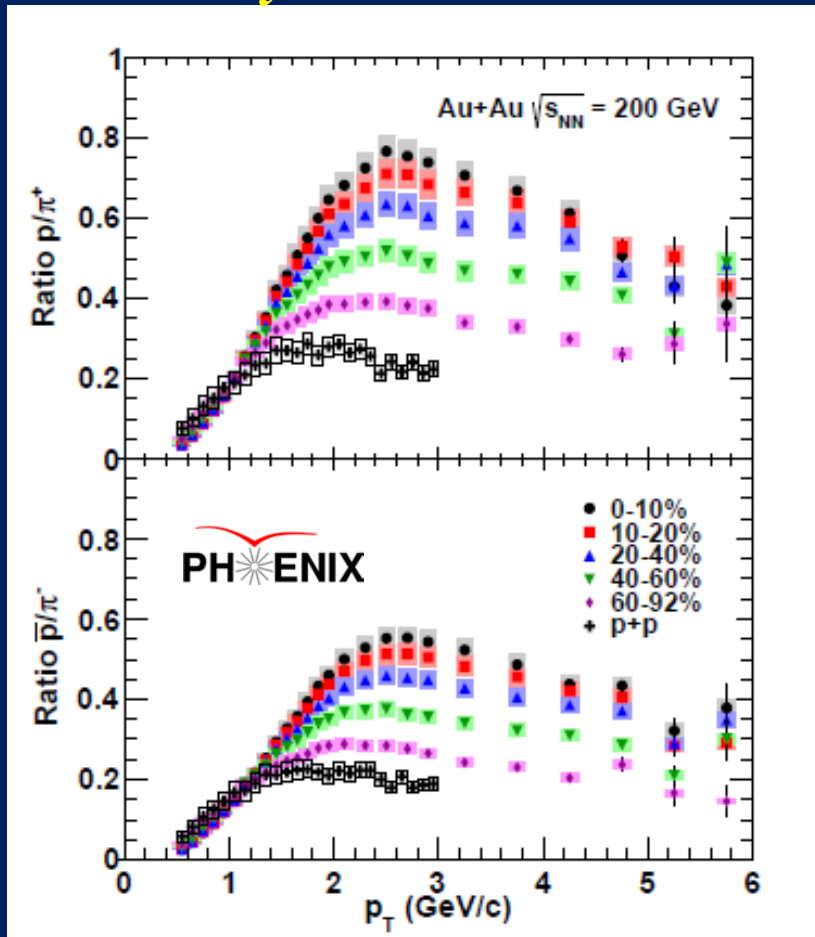

- Precision $d+Au$ data for identified charged hadrons in bins of centrality
- New hadron production mechanism enabled by presence of additional partons/ nucleons
 - Parton recombination?
- Strong centrality dependence despite small range of N_{part} and N_{coll} values in $d+Au$
- Well-known centrality-dependent baryon enhancement in $Au+Au$

PRC88, 024906 (2013)

