

ATHENA+

THE HOT AND ENERGETIC UNIVERSE

1) How does ordinary matter assemble into the large scale structures we see today?

2) How do black holes grow and influence the Universe?"

The Science Theme motivating the Athena+ mission

ATHENA+

Why does the **Observable Universe**
look the way it does?

ATHENA +

Why does the **Observable Universe**
look the way it does?

Perseus Cluster: Optical

ATHENA+

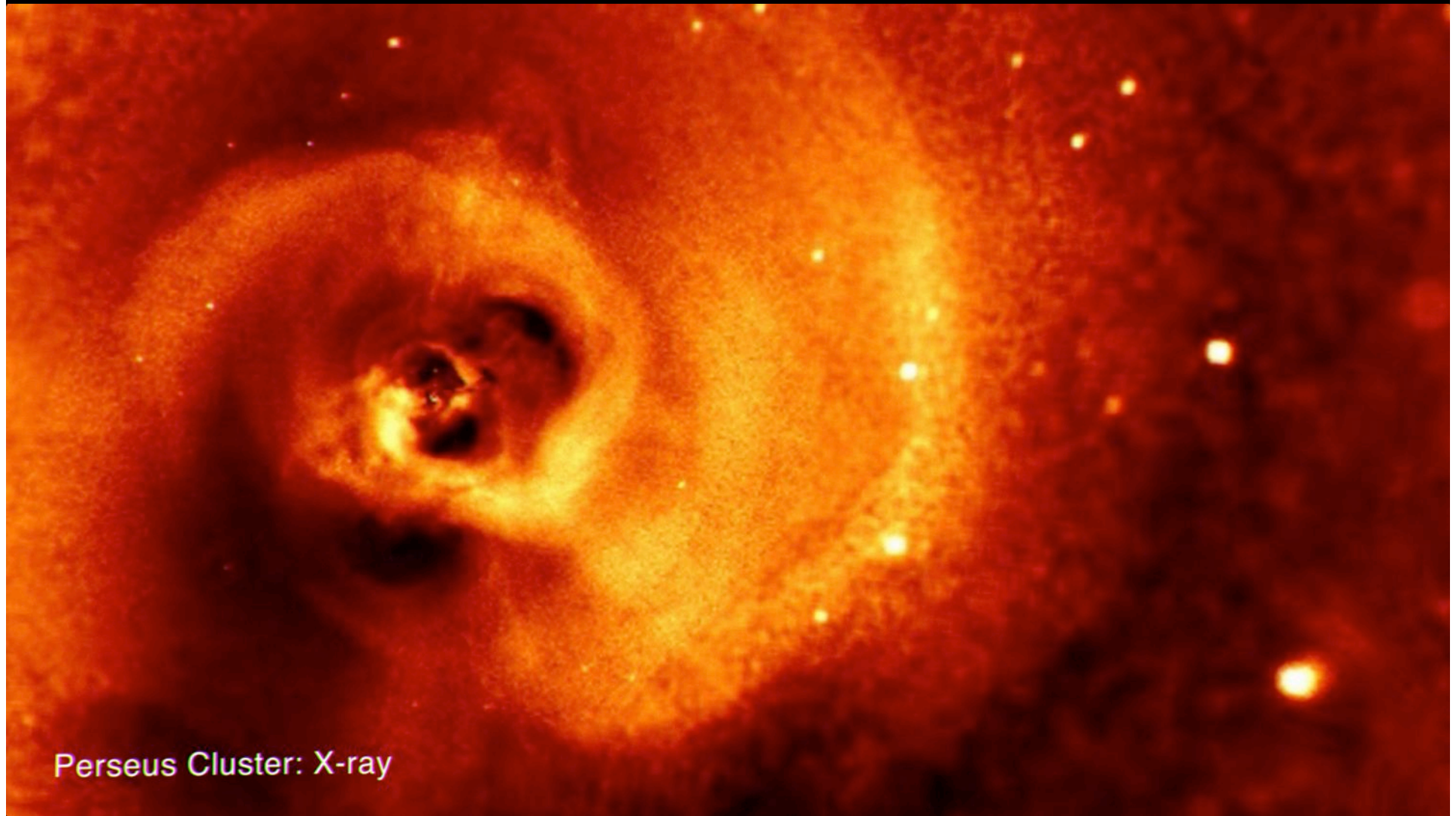

Perseus Cluster: X-ray

ATHENA +

Why does the observable universe look the way it does?

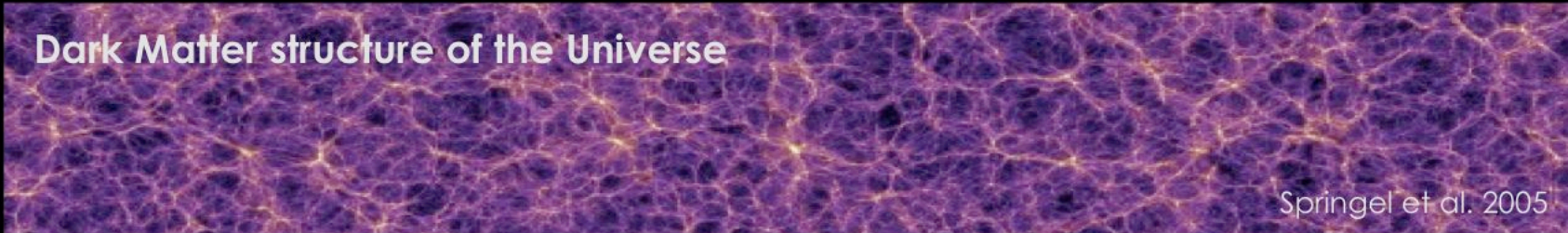

THE COLD UNIVERSE

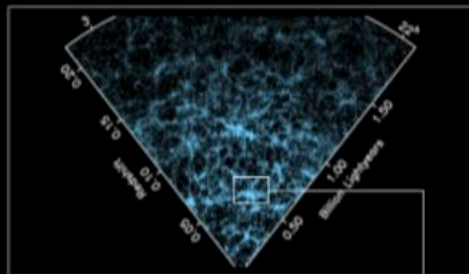

LARGE SCALE GALAXY DISTRIBUTION



STARS AND GALAXIES

THE HOT UNIVERSE

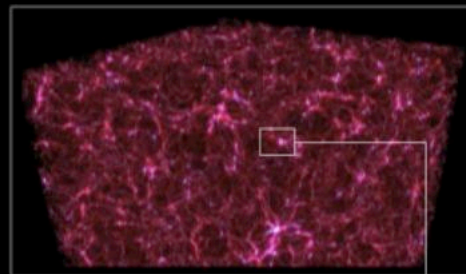

INTERGALACTIC MEDIUM



GALAXY CLUSTERS & GROUPS

THE ENERGETIC UNIVERSE

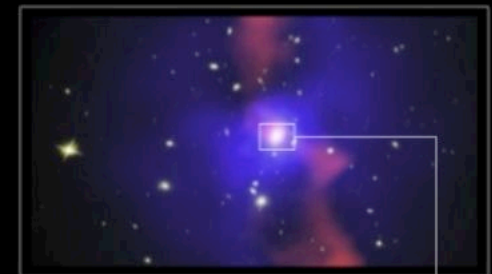

COSMIC FEEDBACK

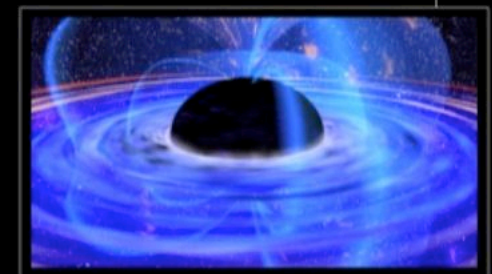

BLACK HOLES

ATHENA +

Key questions for observational astrophysics in 2028

1. How does ordinary matter assemble into the large scale structures we see today?

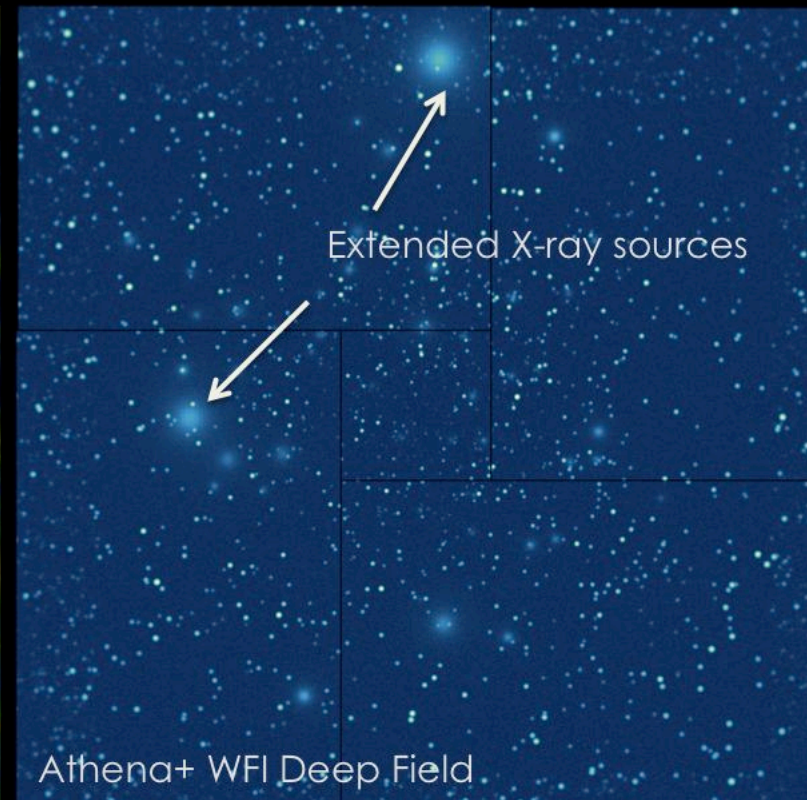
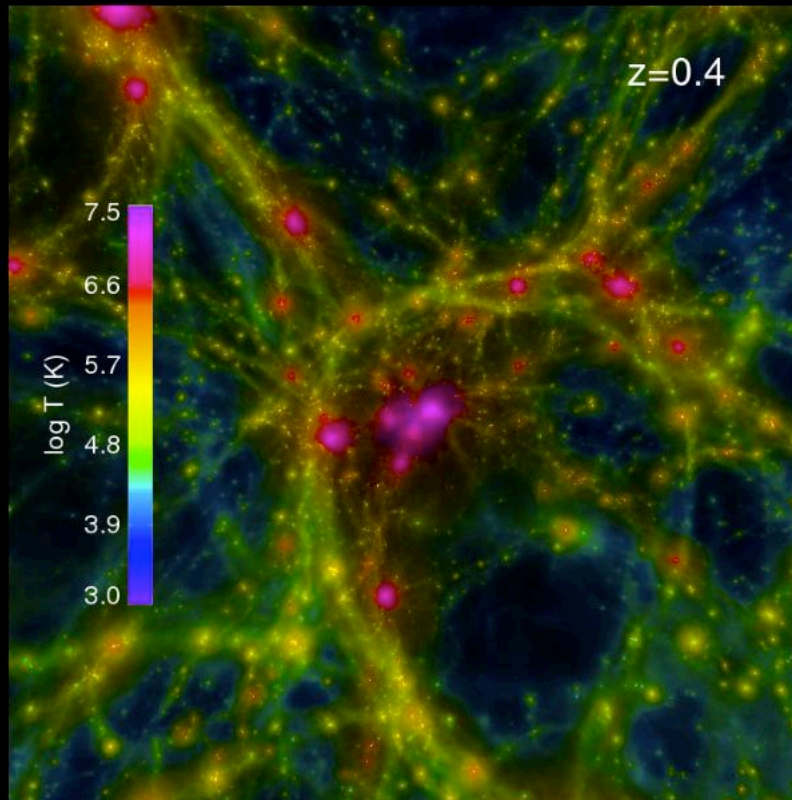

ATHENA+

The formation and evolution of clusters and groups of galaxies

How and when was the energy contained in the hot intra-cluster medium generated?

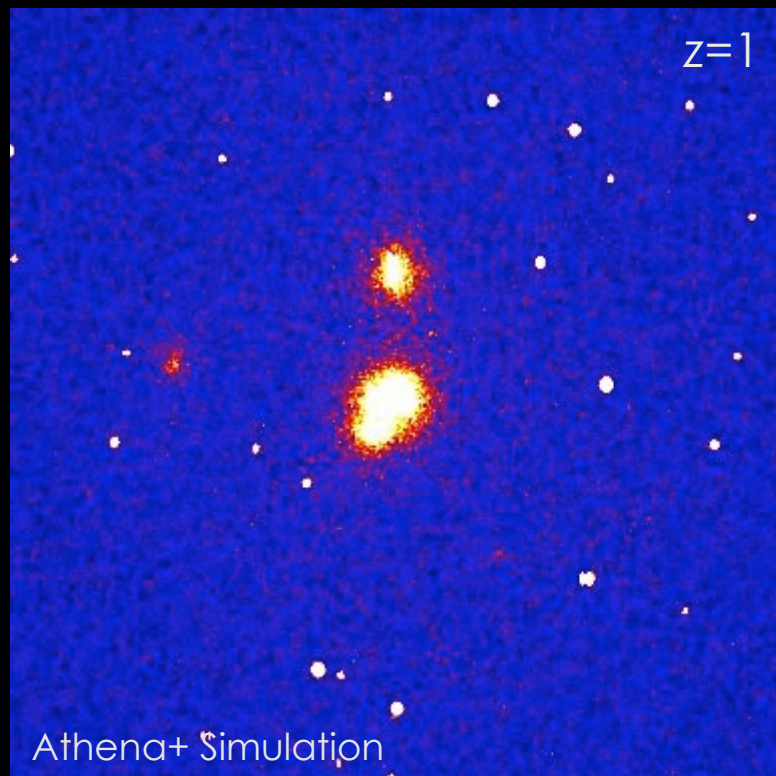

Pointecouteau, Reiprich et al., 2013 arXiv1306.2319

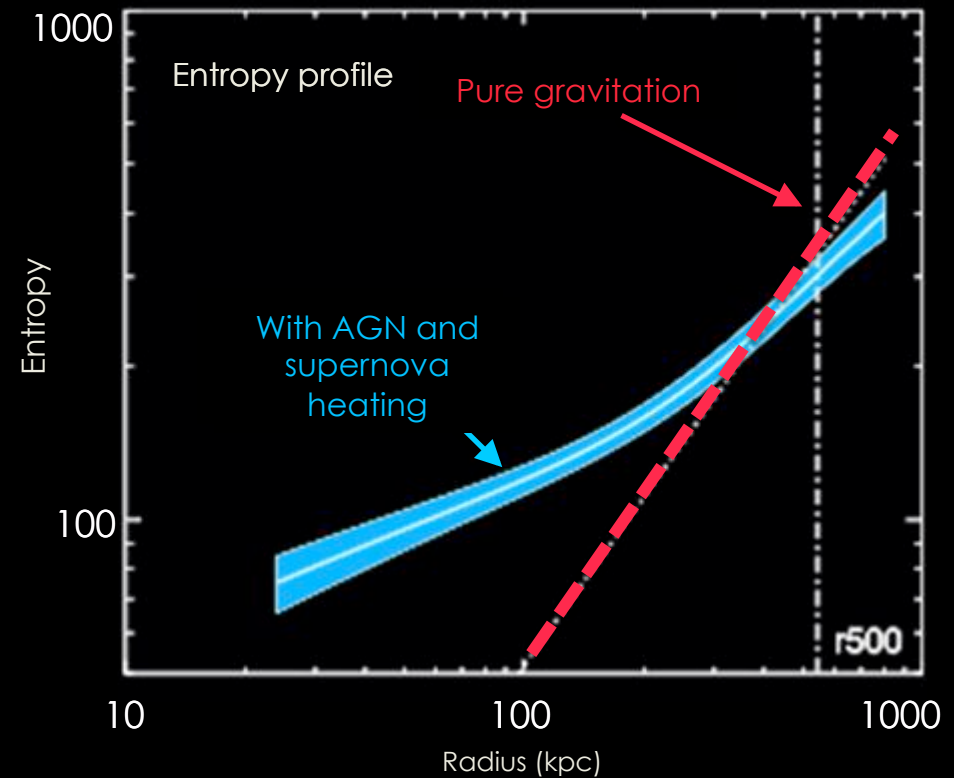

How does ordinary matter assemble into the large-scale structures that we see today?

ATHENA+

The formation and evolution of clusters and groups of galaxies

How and when was the energy contained in the hot intra-cluster medium generated?

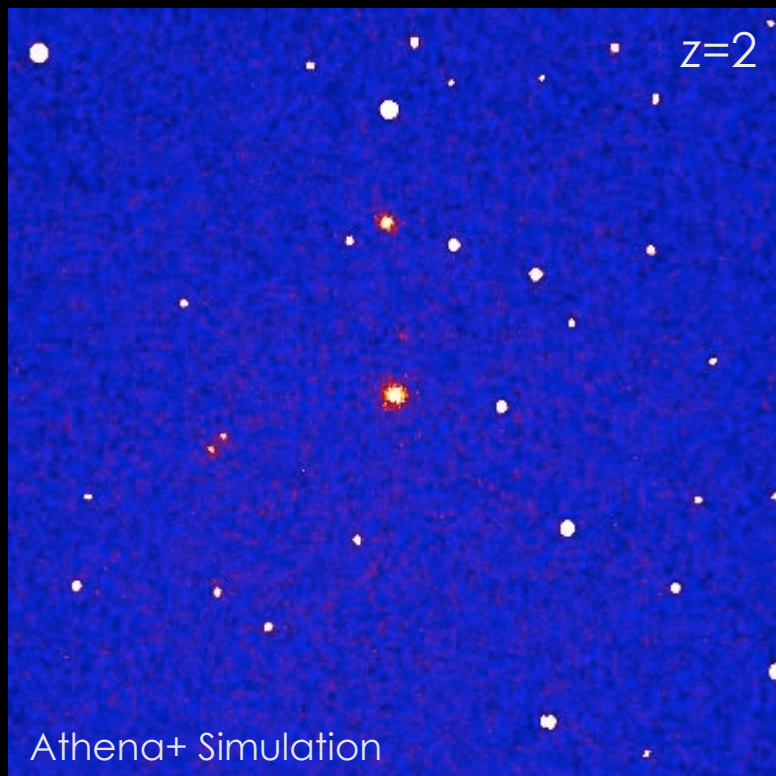

Pointecouteau, Reiprich et al., 2013 arXiv1306.2319

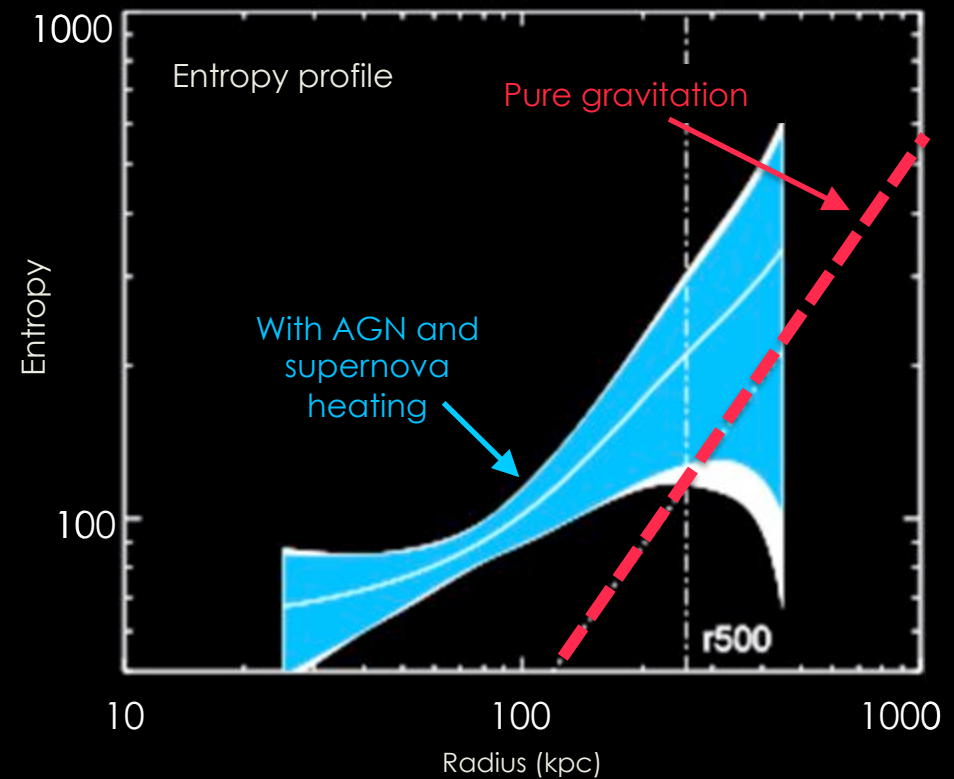

How does ordinary matter assemble into the large-scale structures that we see today?

ATHENA+

The formation and evolution of clusters and groups of galaxies

How and when was the energy contained in the hot intra-cluster medium generated?

Simulated Velocity map

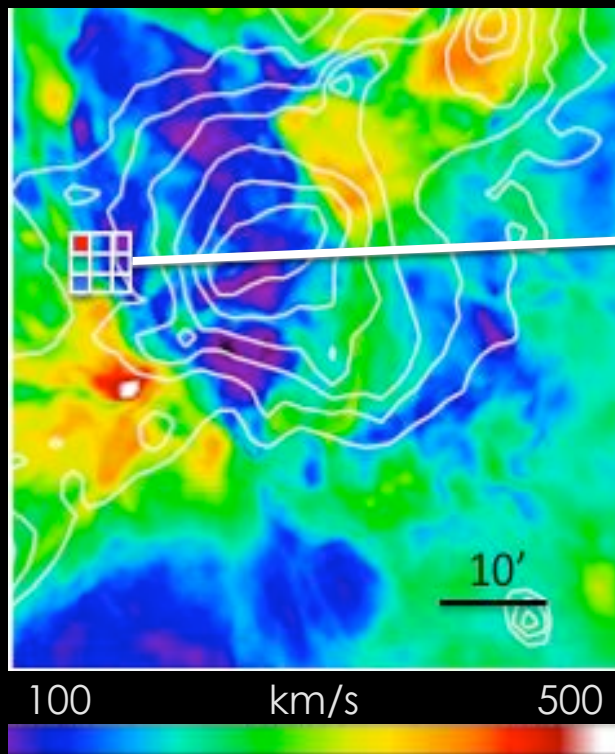

Ettori, Pratt, et al., 2013 arXiv1306.2322

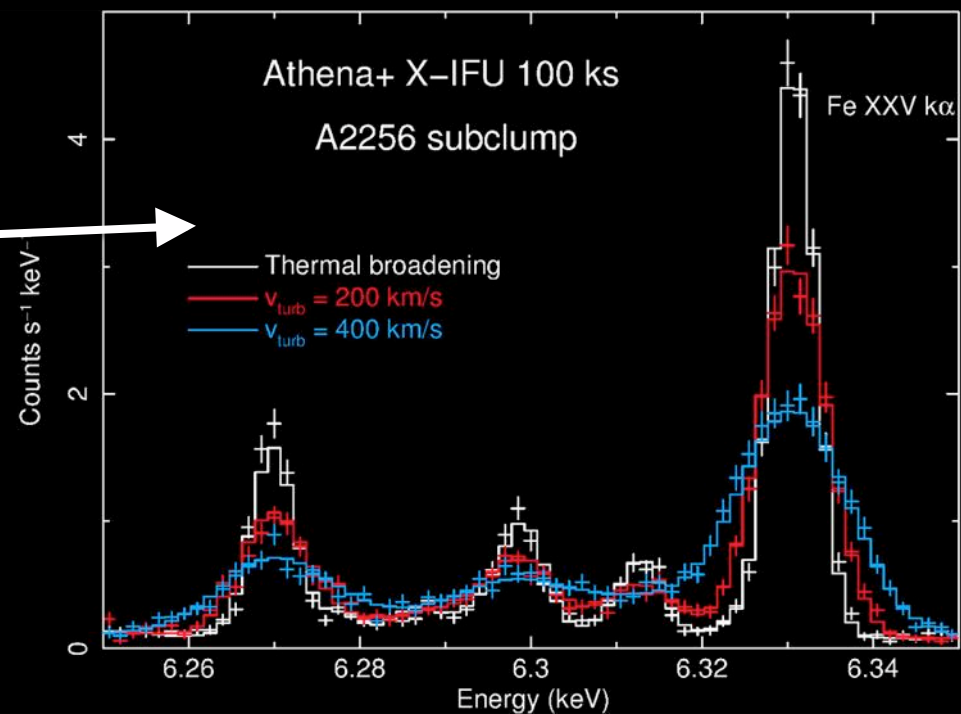

How does ordinary matter assemble into the large-scale structures that we see today?

ATHENA +

The chemical evolution of hot baryons

When and how were the largest baryon reservoirs in galaxy clusters chemically enriched?

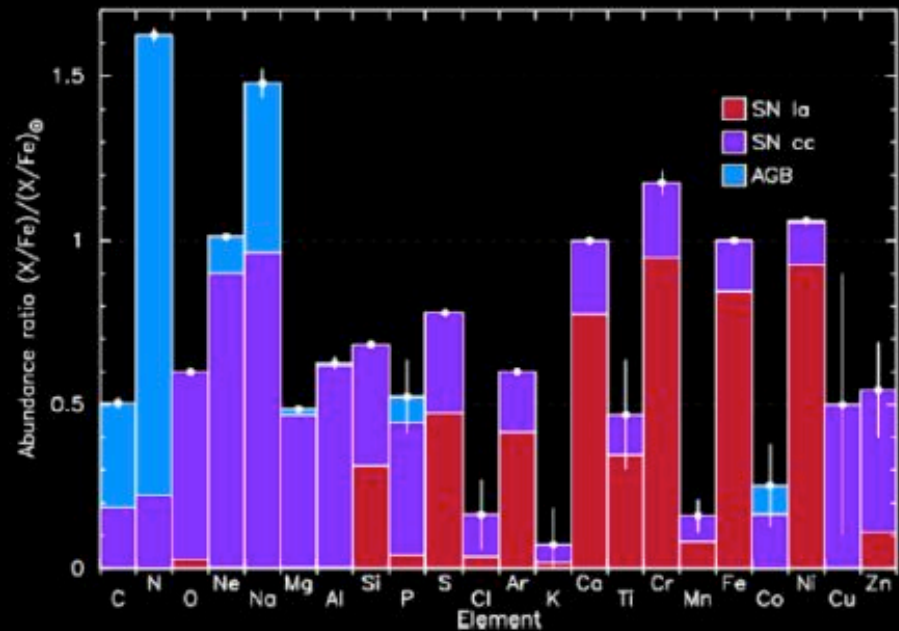
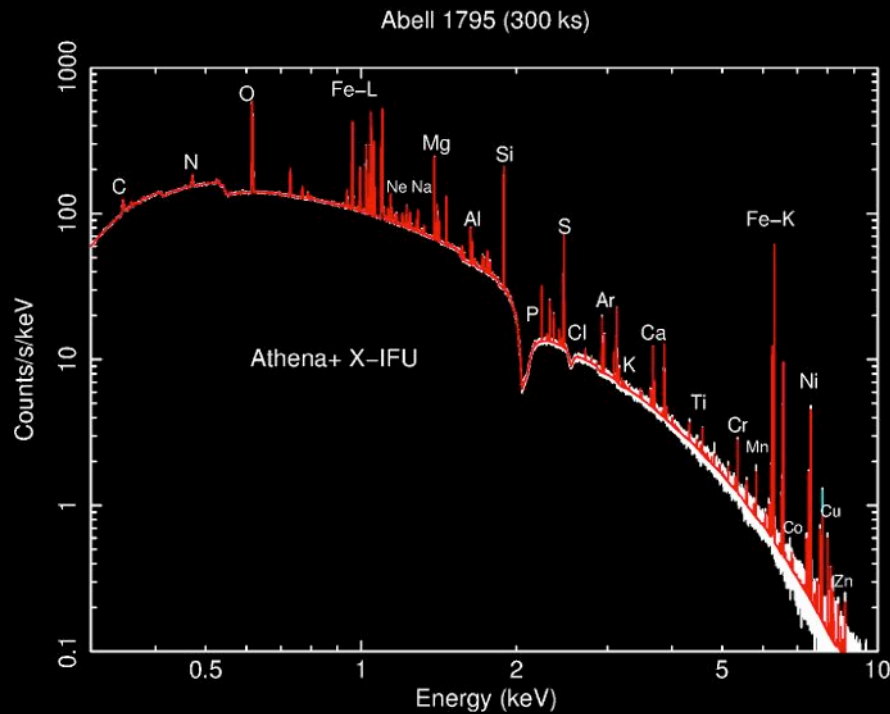

Ettori, Pratt, et al., 2013 arXiv1306.2322

How does ordinary matter assemble into the large-scale structures that we see today?

ATHENA+

The chemical evolution of hot baryons

When and how were the largest baryon reservoirs in galaxy clusters chemically enriched?

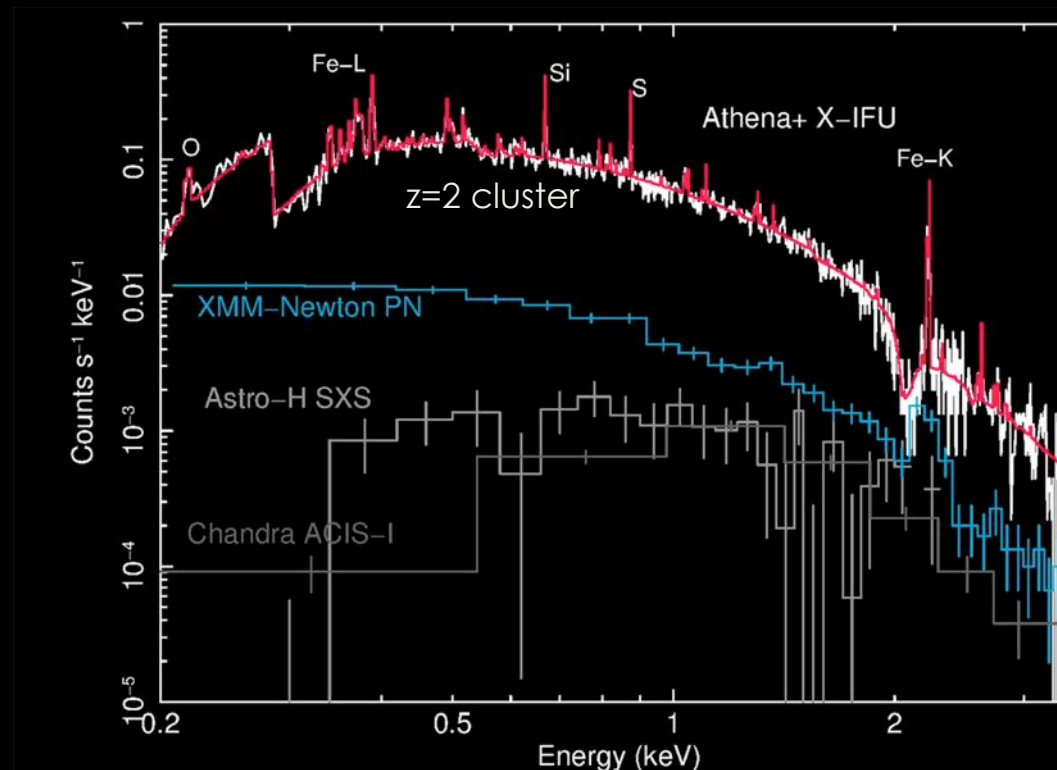

Ettori, Pratt, et al., 2013 arXiv1306.2322

How does ordinary matter assemble into the large-scale structures that we see today?

ATHENA +

The Warm-Hot intergalactic medium (WHIM)

Where are the missing baryons in the local Universe? What is the underlying mechanism determining the distribution of the hot phase of the cosmic web?

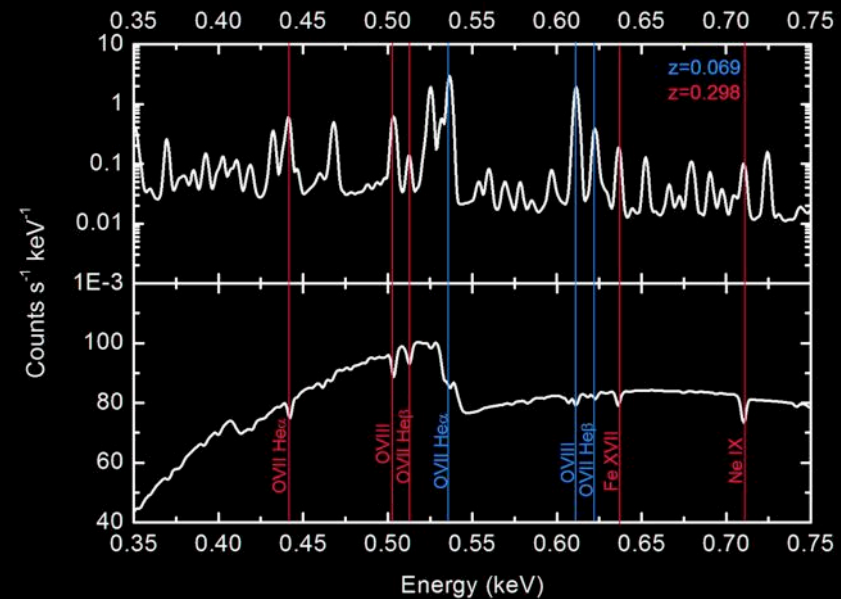
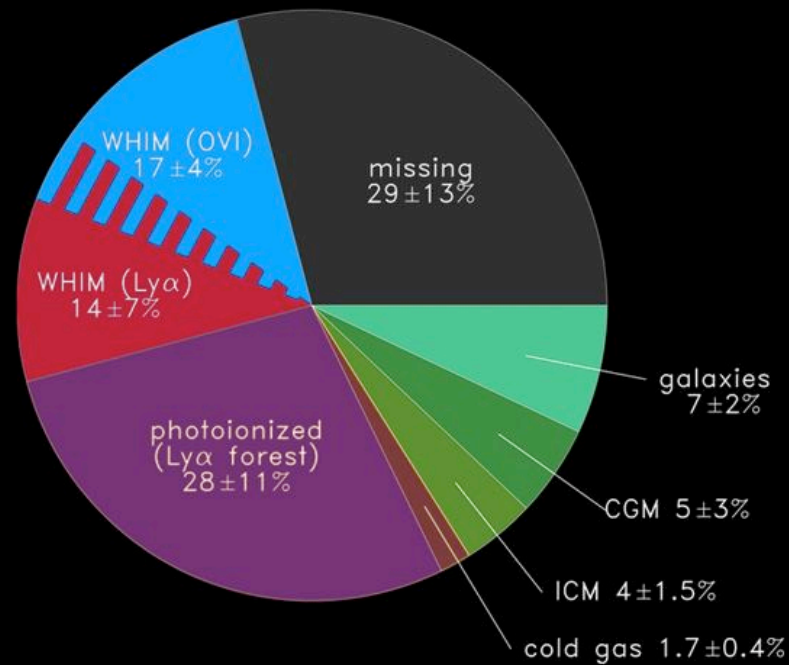

Kaastra, Finoguenov et al., 2013 arXiv1306.2324

How does ordinary matter assemble into the large-scale structures that we see today?

ATHENA+

Key questions for observational astrophysics in 2028

1. How does ordinary matter assemble into the large scale structures we see today?
2. How do black holes grow and shape the Universe?

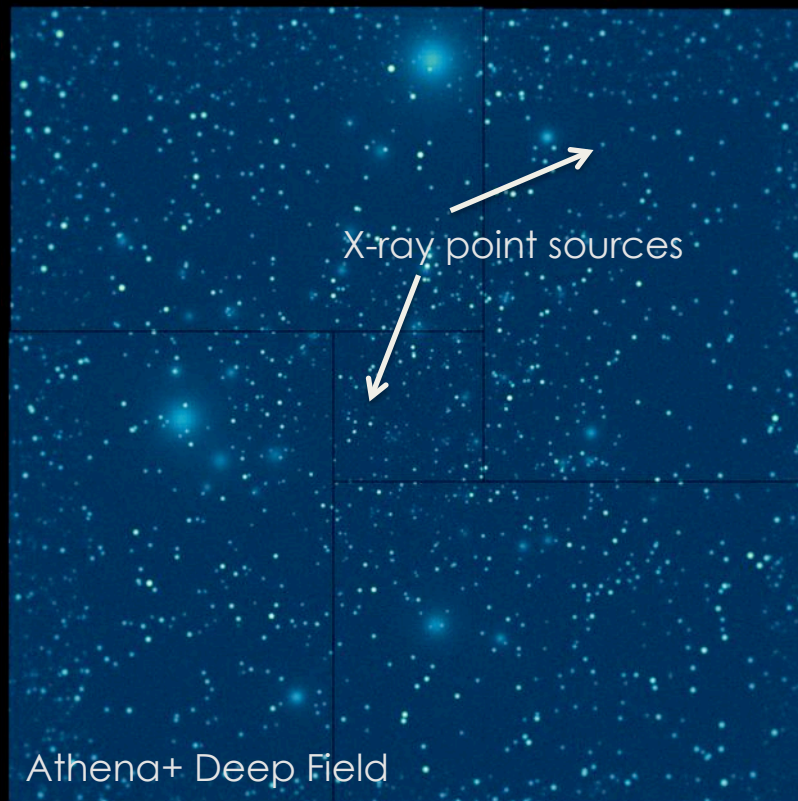

ATHENA +

Cosmic feedback: the origin of black hole winds

How do black holes launch winds and outflows?
How much energy do they carry out to larger scales?

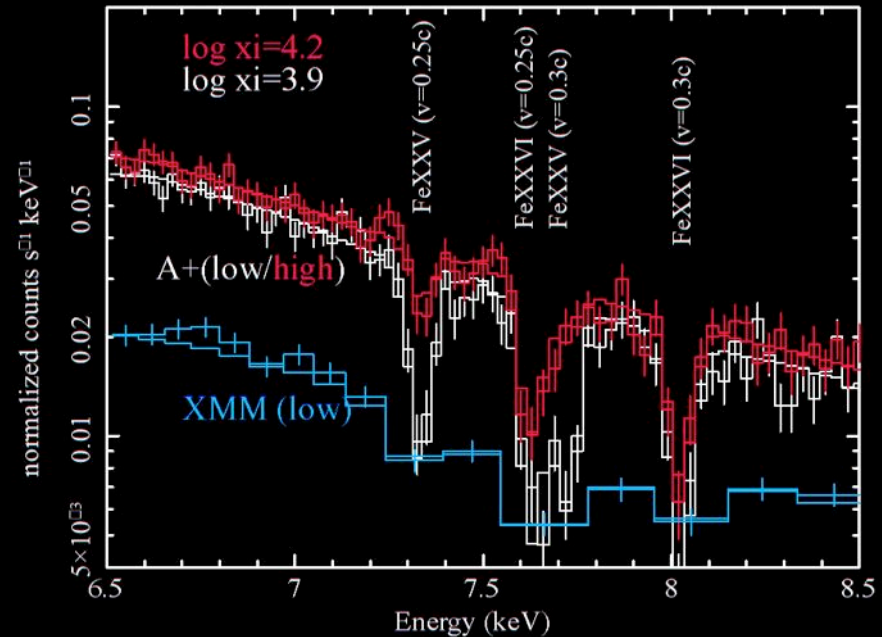
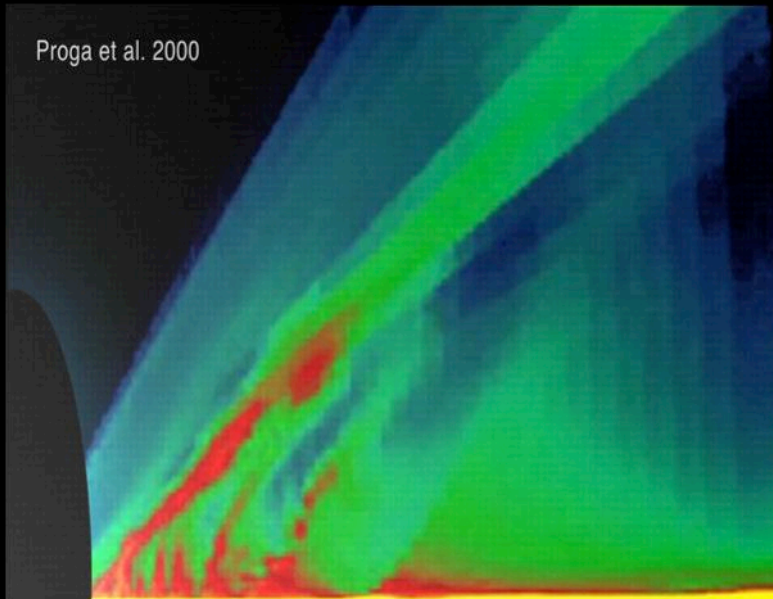

Cappi, Done et al., 2013 arXiv1306.2330
Dovciak, Matt et al., 2013 arXiv1306.2331

How do black holes grow and shape the Universe?

ATHENA +

Cosmic feedback: the impact on galaxy cluster scales

How do jets from Active Galactic Nuclei dissipate their mechanical energy in the hot intracluster medium, and how does this regulate gas cooling and black hole fuelling?

60 arcsec (22 kpc)

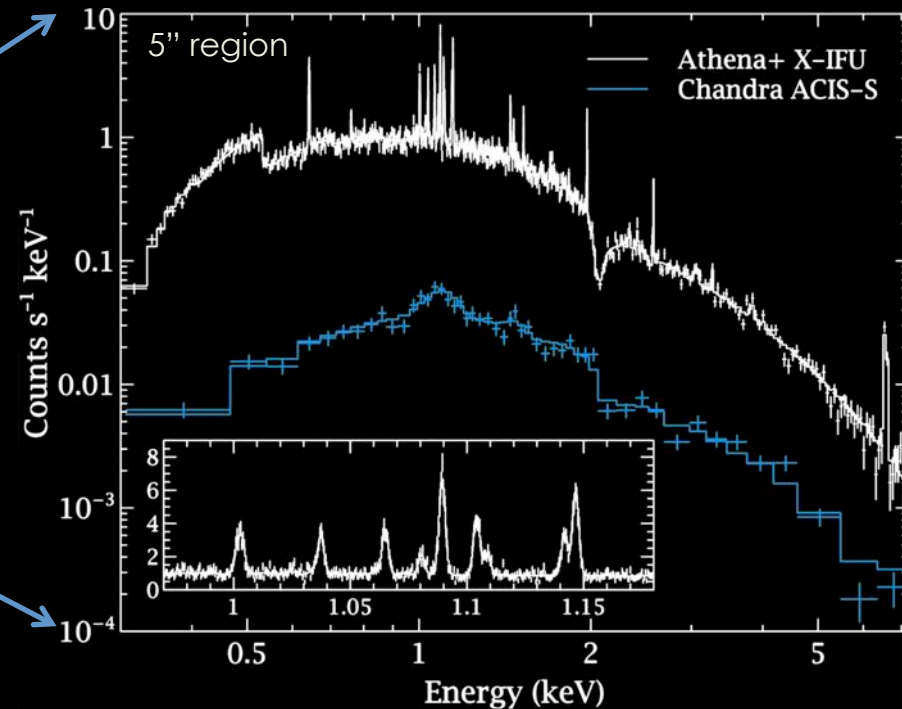
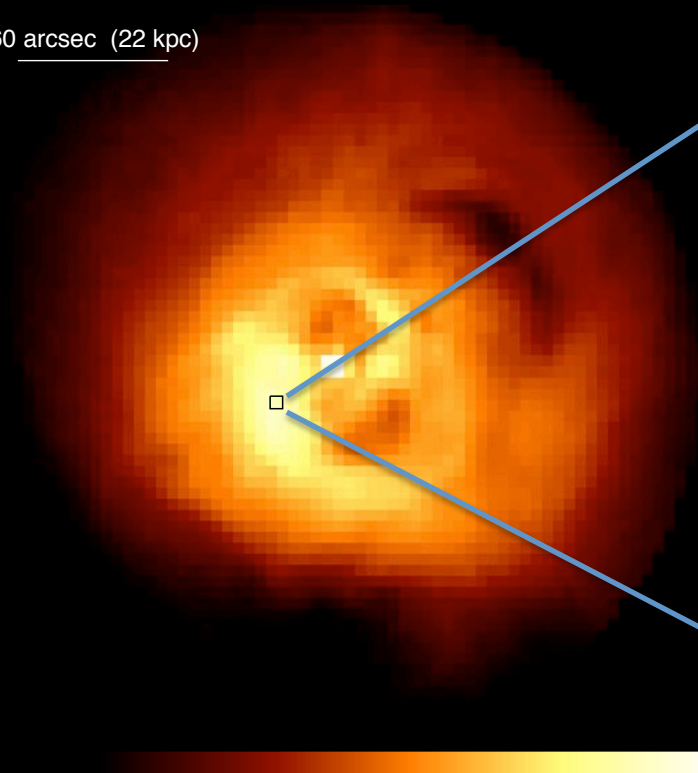

Croston, Sanders et al., 2013 arXiv1306.2323

How do black holes grow and shape the Universe?

ATHENA +

Cosmic feedback: black hole and galaxy co-evolution

How much black hole accretion occurs in the most obscured environments?
How does this relate to the evolution of the host galaxy?

Disk instability

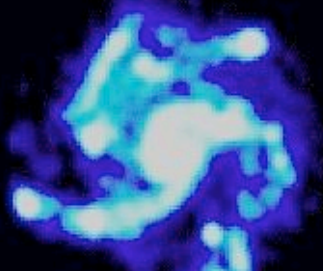

Ceverino et al. 2010

Obscured BH growth



Feedback phase

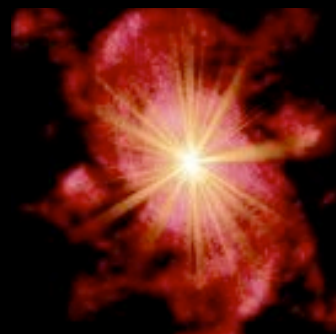

Quiescent remnant



Merger

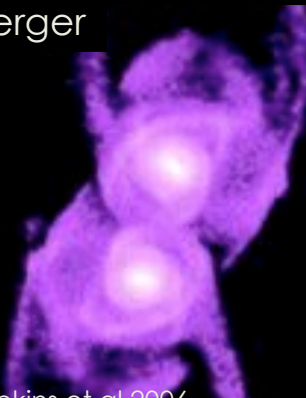

Hopkins et al. 2006

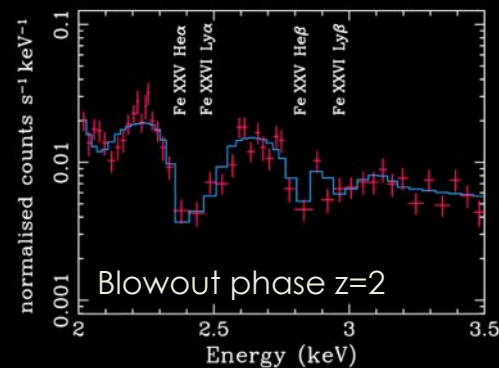
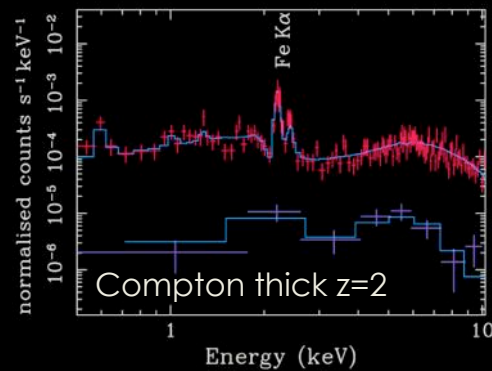

Georgakakis, Carrera et al., 2013 arXiv1306.2328

How do black holes grow and shape the Universe?

ATHENA+

Black hole growth in the early Universe

What was the growth history of black holes in the epoch of reionization?

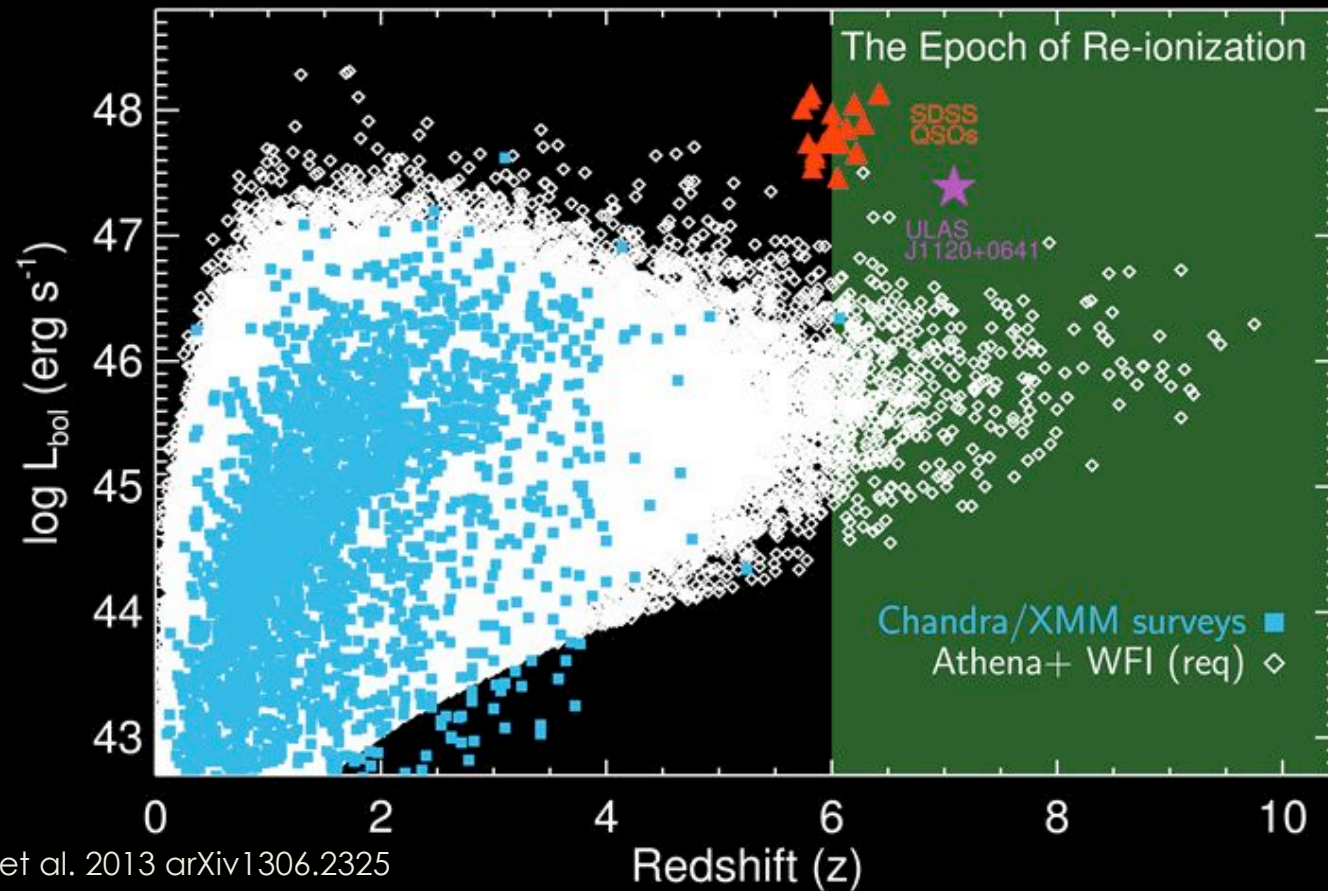

Aird, Comastri et al. 2013 arXiv1306.2325

How do black holes grow and shape the Universe?

ATHENA +

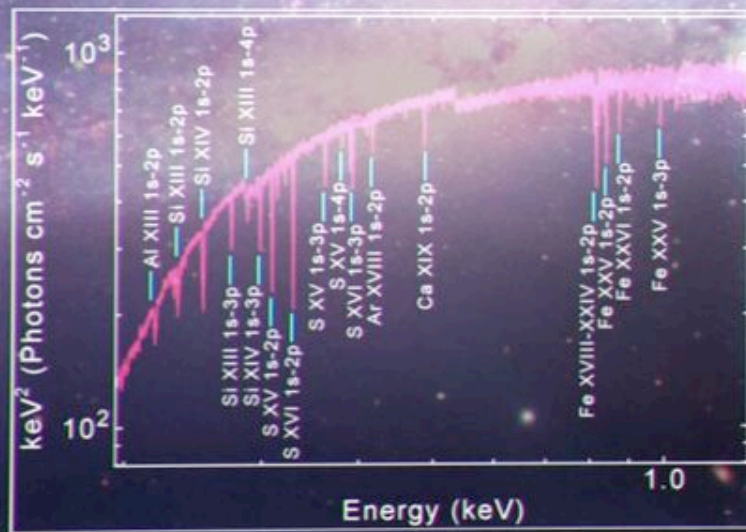

Gamma-ray burst at $z=7$

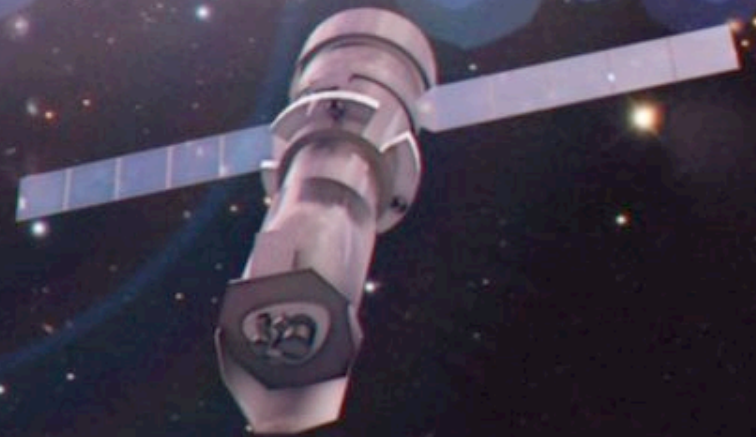

The first stars and black holes

When did the first generation of stars explode to form the first seed black holes and disseminate the first metals in the Universe?

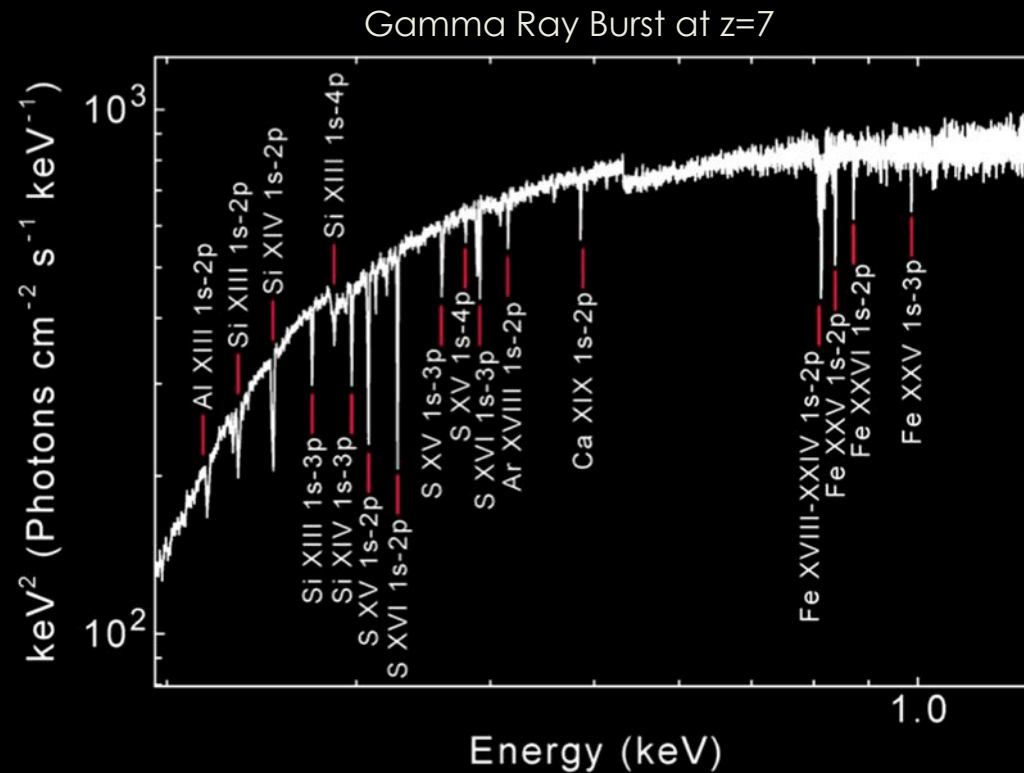

Jonker, O'Brien et al., 2013 arXiv1306.2336

How do black holes grow and shape the Universe?

ATHENA+

THE ATHENA+
OBSERVATORY

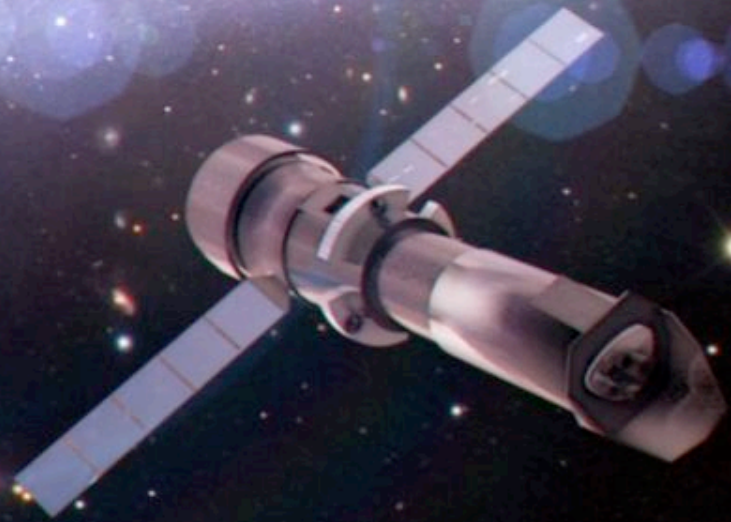

ATHENA+

The Athena+ Observatory

Willingale et al, 2013
arXiv 1308.6785

L2 orbit Ariane V

Mass < 5100 kg
Power 2500 W
5 year mission

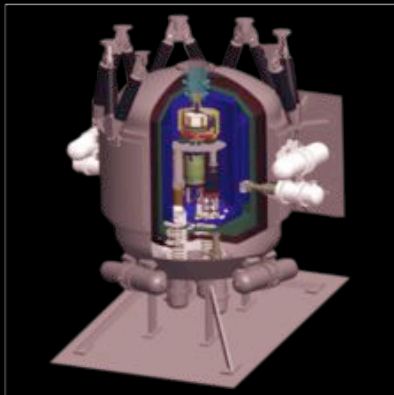

X-ray Integral Field Unit:

ΔE : 2.5 eV
Field of View: 5 arcmin
Operating temp: 50 mk

Barret et al., 2013 arXiv:1308.6784

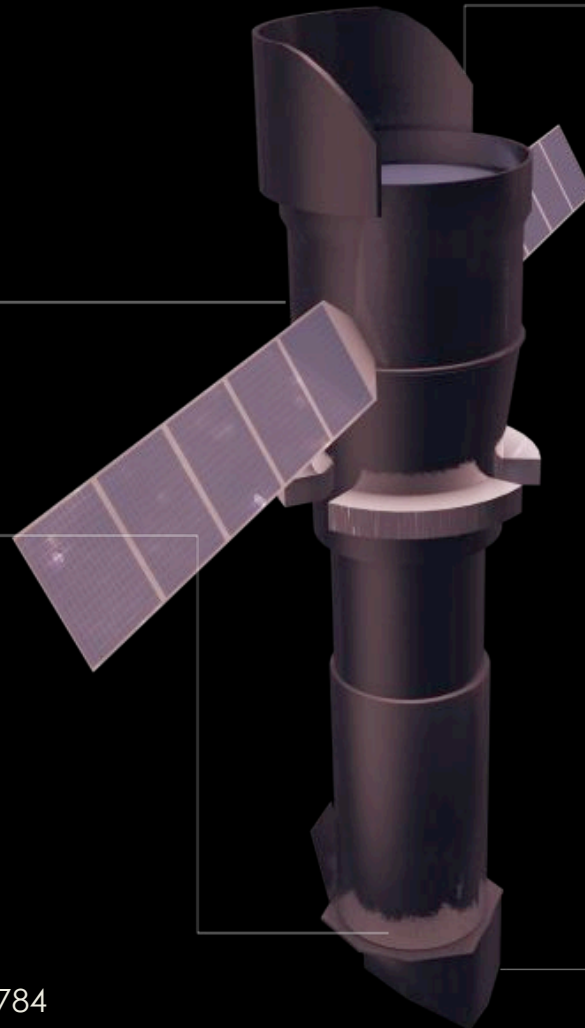

Silicon Pore Optics:

2 m² at 1 keV
5 arcsec HEW
Focal length: 12 m
Sensitivity: 3 10⁻¹⁷ erg cm⁻²s⁻¹

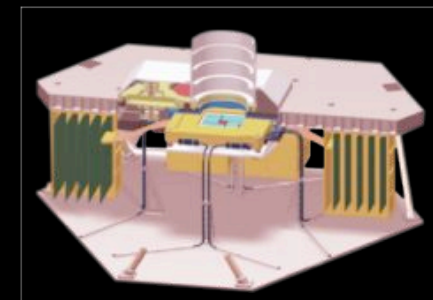

Wide Field Imager:

ΔE : 125 eV
Field of View: 40 arcmin
High countrate capability

Rau et al. 2013 arXiv 1307.1709

ATHENA +

Technical Maturity

IXO (Ariane 5)

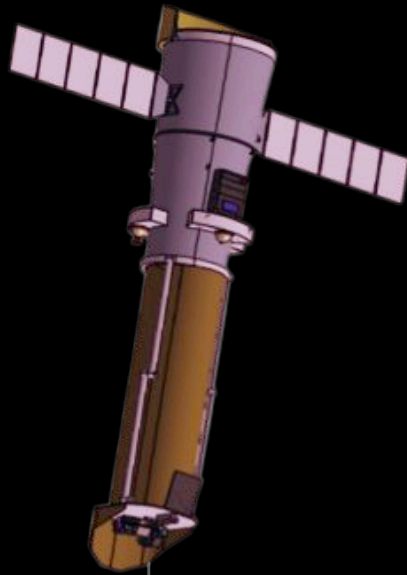

Simplified:

5 to 2 instruments
Extendible to fixed OB



Athena L1

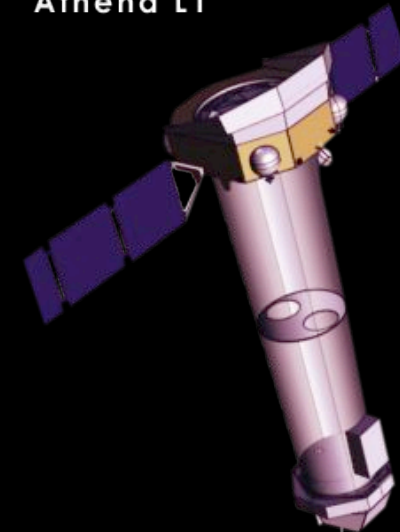

Enhanced:

Angular resolution now 5"
Fields of view increase x 4
Effective area increase x 4
(per instrument)

ATHENA+

The first Deep Universe X-ray Observatory

Athena+ has vastly improved capabilities compared to current or planned facilities, and will provide **transformational** science in virtually all areas of astrophysics

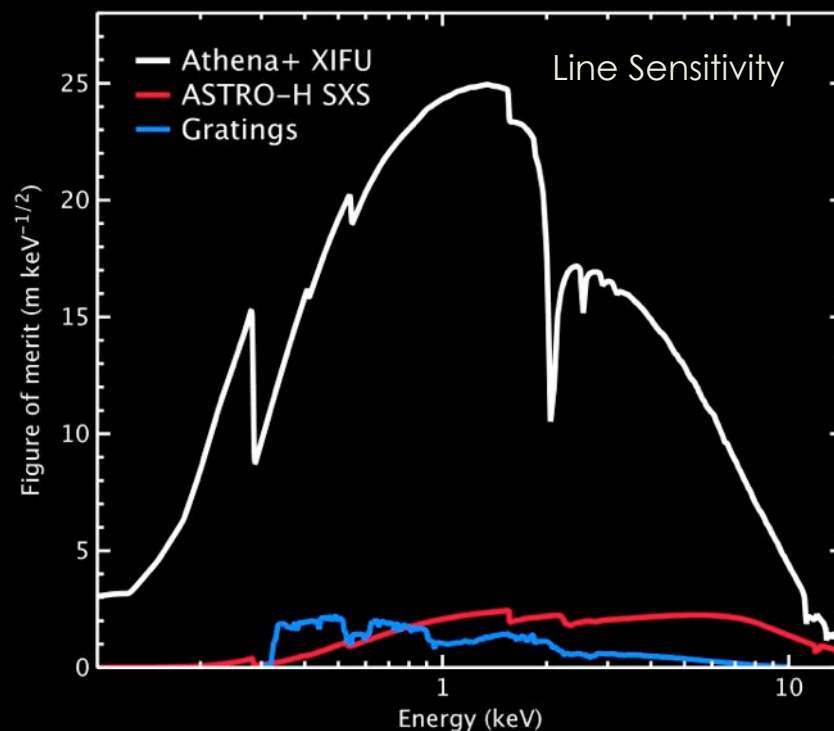

X-ray spectroscopy at the peak of the activity of the Universe

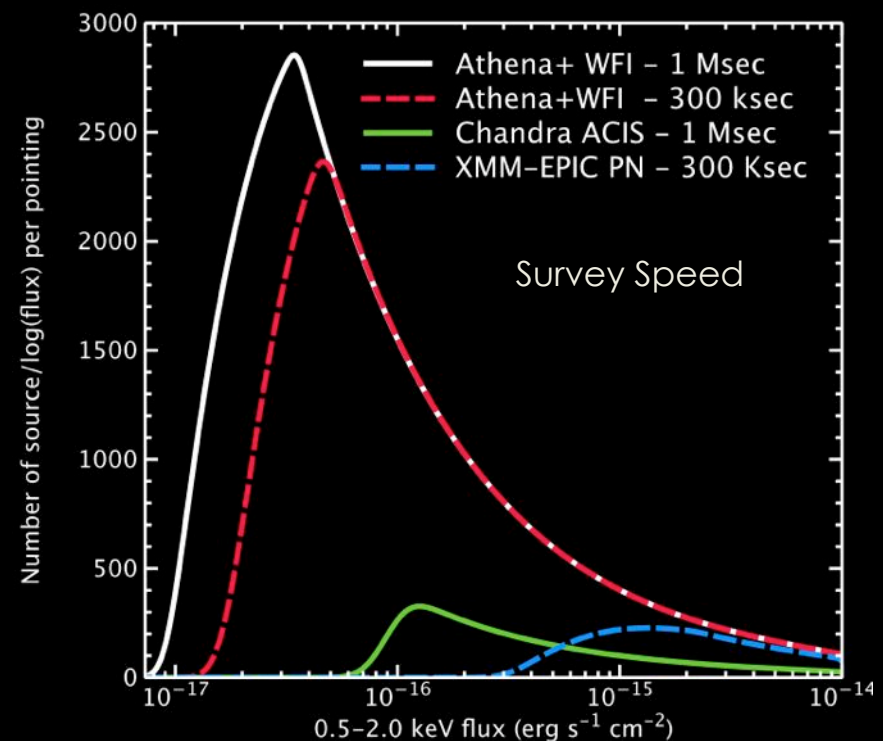

Deep survey capability into the dark ages and epoch of reionization

ATHENA+

Athena+: a powerful observatory

Planets

(interaction of solar wind with planet environment and comets)

Exoplanets

Stellar physics

Supernovae

(explosion mechanism, heavy element production)

Stellar endpoints

(physics of outflows and winds in X-ray binaries)

Sgr A*

Interstellar dust and medium

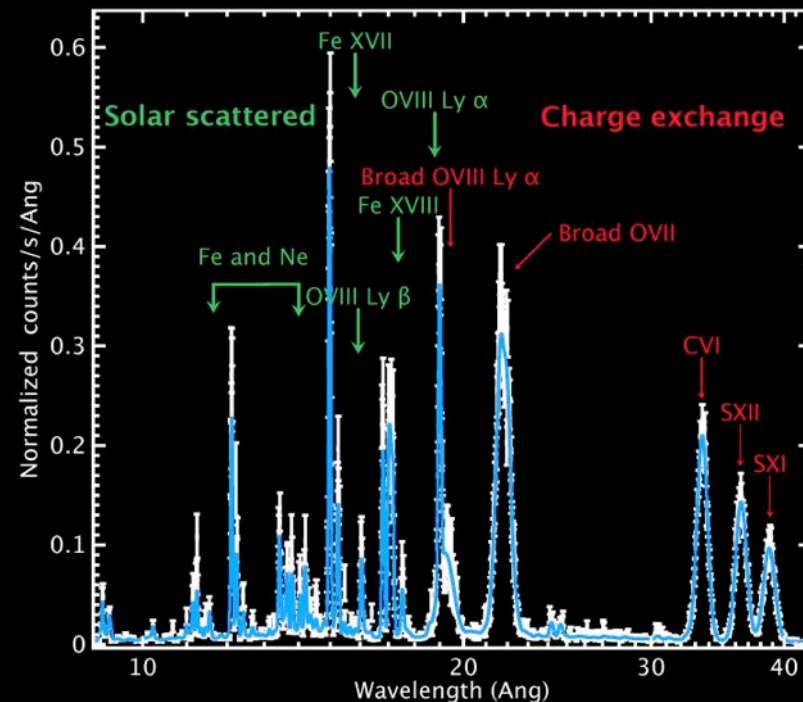

Jupiter

Branduardi-Raymont, Sciortino, et al., 2013 arXiv 1306.2332; Sciortino, Rauw et al., 2013 arXiv1306.2333;
Motch, Wilms, et al., 2013 arXiv1306.2334; Decourchelle, Costantini et al., 2013 arXiv1306.2335

ATHENA+

Athena+: a powerful observatory

Planets

(interaction of solar wind with planet environment and comets)

Exoplanets

Stellar physics

Supernovae

(explosion mechanism, heavy element production)

Stellar endpoints

(physics of outflows and winds in X-ray binaries)

Sgr A*

Interstellar dust and medium

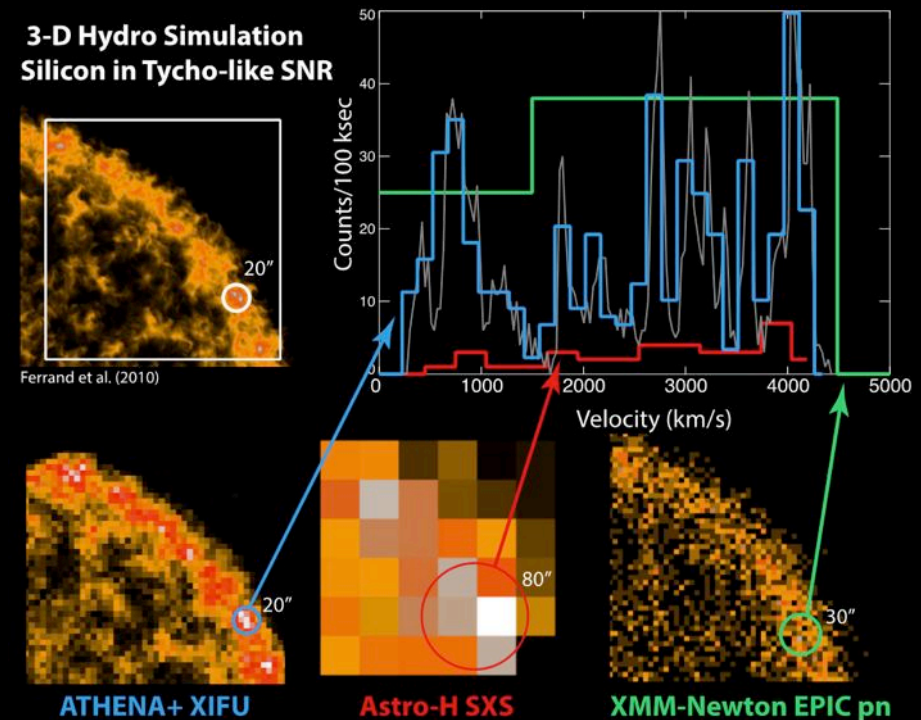

Branduardi-Raymont, Sciortino, et al., 2013 arXiv 1306.2332; Sciortino, Rauw et al., 2013 arXiv1306.2333;
Motch, Wilms, et al., 2013 arXiv1306.2334; Decourchelle, Costantini et al., 2013 arXiv1306.2335

ATHENA+

Athena+: a powerful observatory

Planets

(interaction of solar wind with planet environment and comets)

Exoplanets

Stellar physics

Supernovae

(explosion mechanism, heavy element production)

Stellar endpoints

(physics of outflows and winds in X-ray binaries)

Sgr A*

Interstellar dust and medium

Outflow in X-ray binary, 10ks

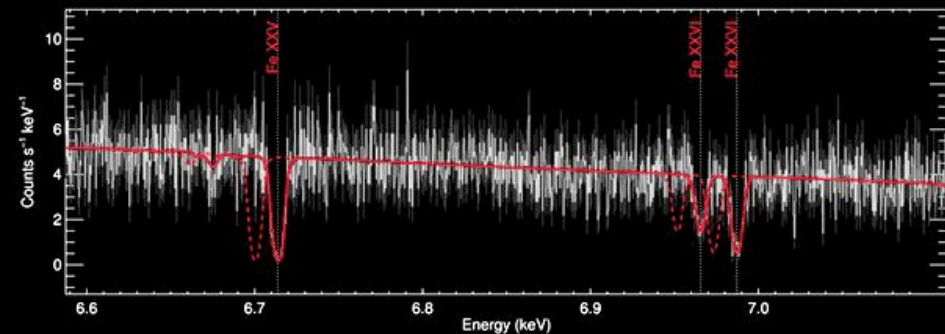

Branduardi-Raymont, Sciortino, et al., 2013 arXiv 1306.2332; Sciortino, Rauw et al., 2013 arXiv1306.2333;
Motch, Wilms, et al., 2013 arXiv1306.2334; Decourchelle, Costantini et al., 2013 arXiv1306.2335

ATHENA+

Athena+ science in context



Athena+ is a crucial part of the suite of large observatories needed to reach the science objectives of astronomy in the coming decades

Acknowledgements

The Athena+ Co-ordination Group: Xavier Barcons (ES), Didier Barret (FR), Andy Fabian (UK), Jan-Willem den Herder (NL), Kirpal Nandra (DE), Luigi Piro (IT), Mike Watson (UK)

The Athena+ Working Groups: Christophe Adami (FR), **James Aird (UK)**, Jose Manuel Afonso (PT), Dave Alexander (UK), Costanza Argiroffi (IT), Monique Arnaud (FR), Jean-Luc Asteia (F), Marc Audard (CH), Carles Badenes (US), Jean Ballet (FR), Lucia Ballo (IT), Aya Bamba (JP), Anil Bhardwaj (IN), Elia Stefano Battistelli (IT), Werner Becker (DE), Michaël De Becker (BE), Ehud Behar (IL), Stefano Bianchi (IT), Veronica Biffi (IT), Laura Bîrzan (NL), Fabrizio Bocchino (IT), Slavko Bogdanov (US), Laurence Bolrin (FR), Thomas Boller (DE), Stefano Borgani (IT), Katharina Borm (DE), Hervé Bourdin (IT), Richard Bower (UK), Valentina Braitto (IT), Enzo Branchini (IT), **Graziella Branduardi-Raymont (UK)**, Joel Bregman (USA), Laura Brenneman (USA), Murray Brightman (DE), Marcus Brügggen (DE), Johannes Buchner (DE), Esra Bulbul (USA), Marcella Brusa (IT), Michal Bursa (CZ), Alessandro Caccianiga (IT), Ed Cackett (USA), Sergio Campana (IT), Nico Cappelluti (IT), **Massimo Cappi (IT)**, **Francisco Carrera (ES)**, Maïte Ceballos (ES), Finn Christensen (DK), You-Hua Chu (US), Eugene Churazov (DE), Nicolas Clerc (DE), Stephane Corbel (F), Amalia Corral (GR), **Andrea Comastri (IT)**, **Elisa Costantini (NL)**, **Judith Croston (UK)**, Mauro Dadina (IT), Antonino D'Al (IT), **Anne Decourchelle (FR)**, Roberto Della Ceca (IT), Konrad Dennerl (DE), Klaus Dolag (DE), **Chris Done (UK)**, **Michal Dovciak (CZ)**, Jeremy Drake (US), Dominique Eckert (S), Alastair Edge (UK), **Stefano Effori (IT)**, Yuichiro Ezoë (JP), Eric Feigelson (US), Rob Fender (UK), Chiara Feruglio (FR), **Alexis Finoguenov (FI)**, Fabrizio Fiore (IT), Massimiliano Galeazzi (IT), Sarah Gallagher (CA), Poshak Gandhi (UK), Massimo Gaspari (IT), Fabio Gastaldello (IT), **Antonis Georgakakis (DE)**, Ioannis Georgantopoulos (GR), Marat Gilfanov (DE), Myriam Gitti (IT), Randy Gladstone (USA), Rene Goosmann (FR), Eric Gosset (BE), Nicolas Grosso (FR), Manul Guedel (AT), Martin Guerrero (ES), Frank Haberl (DE), Martin Hardcastle (UK), Sebastian Heinz (US), Almudena Alonso Herrero (ES), Anthony Hervé (FR), Mats Holmstrom (SE), Kazushi Iwasawa (ES), **Peter Jonker (NL)**, **Jelle Kaastra (NL)**, Erin Kara (UK), Vladimir Karas (CZ), Joel Kastner (US), Andrew King (UK), Daria Kosenko (FR), Dimita Koutroumpa (FR), Ralph Kraft (US), Ingo Kreykenbohm (D), Rosine Lallement (FR), J. Lee (US), Marianne Lemoine-Goumard (FR), Andrew Lobban (UK), Giuseppe Lodato (IT), Lorenzo Lovisari (DE), Ian McCarthy (UK), Brian McNamara (CA), Antonio Maggio (IT), Roberto Maiolino (UK), Barbara De Marco (DE), Silvia Mateos (ES), **Giorgio Matt (IT)**, Ben Maughan (UK), Pasquale Mazzotta (IT), Mariano Mendez (NL), Andrea Merloni (DE), Giuseppina Micela (IT), Marco Miceli (IT), Robert Mignani (IT), Jon Miller (US), Giovanni Miniutti (ES), Silvano Molendi (IT), Rodolfo Montez (ES), Alberto Moretti (IT), **Christian Motch (FR)**, Yaël Nazé (BE), Jukka Nevalainen (FI), Fabrizio Nicastro (IT), Paul Nuisen (US), Takaya Ohashi (JP), **Paul O'Brien (UK)**, Julian Osborne (UK), Lida Oskinova (DE), Florian Pacaud (DE), Frederik Paerels (US), Mat Page (UK), Iossif Papadakis (GR), Giovanni Pareschi (IT), Robert Petre (US), Pierre-Olivier Petrucci (FR), Enrico Piconcelli (IT), Ignazio Pillitteri (IT), C. Pinto (UK), Jelle de Plaa (NL), **Efienne Pointecouteau (FR)**, Trevor Ponman (UK), Gabriele Ponti (DE), Delphine Porquet (FR), Ken Pounds (UK), **Gabriel Pratt (FR)**, Peter Predehl (DE), Daniel Proga (US), Dimitrios Psaltis (US), David Rafferty (NL), Miriam Ramos-Ceja (DE), Piero Ranalli (IT), Elena Rasia (US), Arne Rau (DE), **Gregor Raau (BE)**, Nanda Rea (IT), Andy Read (UK), James Reeves (UK), **Thomas Reiprich (DE)**, Matthieu Renaud (FR), Chris Reynolds (US), Guido Risaliti (IT), Jerome Rodriguez (FR), Paola Rodriguez Hidalgo (CA), Mauro Roncarelli (IT), David Rosario (DE), Mariachiara Rossetti (IT), Agata Roszanska (PL), Emmanouil Rovilos (UK), Ruben Salvaterra (IT), Mara Salvato (DE), Tiziana Di Salvo (IT), **Jeremy Sanders (DE)**, Jorge Sanz-Forcada (ES), Kevin Schawinski (CH), Joop Schaye (NL), **Salvatore Sciorino (IT)**, Paola Severgnini (I), Francesco Shankar (FR), Stuart Sim (IE), Christian Schmid (DE), Randall Smith (US), Andrew Steiner (US), Beate Stelzer (IT), Gordon Stewart (UK), Tod Strohmayer (US), Lothar Strüder (DE), Ming Sun (US), Yoh Takei (JP), Andreas Tiengo (IT), Francesco Tombesi (US), Ginevra Trinchieri (IT), Asif ud-Doula (US), Eugenio Ursino (NL), Lynne Valencic (US), Eros Vanzella (IT), Simon Vaughan (UK), Cristian Vignali (IT), Jacco Vink (NL), Fabio Vito (IT), Marta Volonteri (FR), Daniel Wang (US), Natalie Webb (FR), Richard Willingale (UK), **Joern Wilms (DE)**, Michael Wise (NL), Diana Worrall (UK), Andrew Young (UK), Luca Zampieri (IT), Jean In't Zand (NL), Andreas Zezas (GR), Yuying Zhang (DE), Irina Zhuravleva (US)

Bold Face Denotes Working Group Chairs

Athena+ Coordination Group:

K. Nandra, D. Barret, X. Barcons, J.-W. den Herder, A. Fabian, L. Piro, M. Watson

Athena+ Working Groups

(~250 people)

Athena+ supporters

(~ 1200 astronomers)

Special thanks to the review team:

M. Arnaud, J. Bregman, F. Combes, R. Kennicutt, R. Maiolino, R. Mushotzky, T. Ohashi, K. Pounds, C. Reynolds, H. Röttgering, M. Rowan-Robinson, C. Turon, G. Zamorani

More information, white paper, 15 supporting papers at:

<http://the-athena-x-ray-observatory.eu/>

ATHENA+

Athena+

The first Deep Universe X-ray Observatory

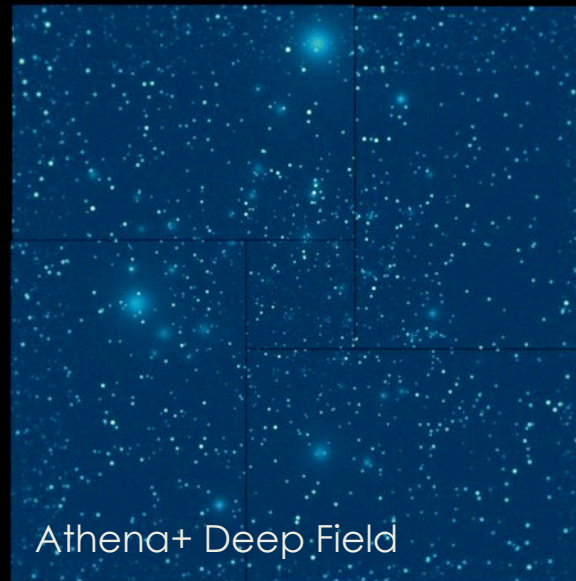
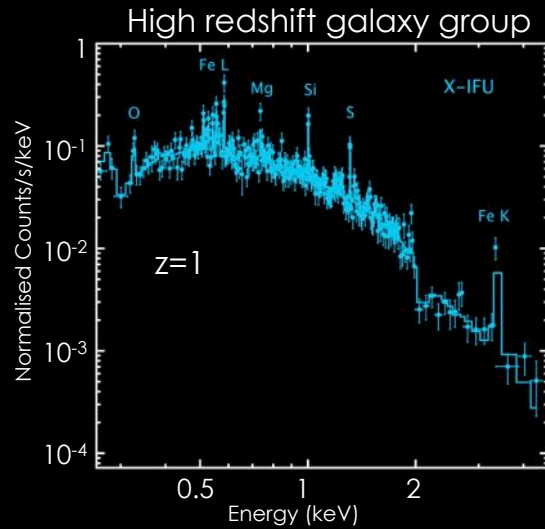

Nandra, Barret, Barcons, Fabian,
den Herder, Piro, Watson et al.
2013 arXiv 1306.2307

Primordial stellar populations
via GRB afterglow follow up

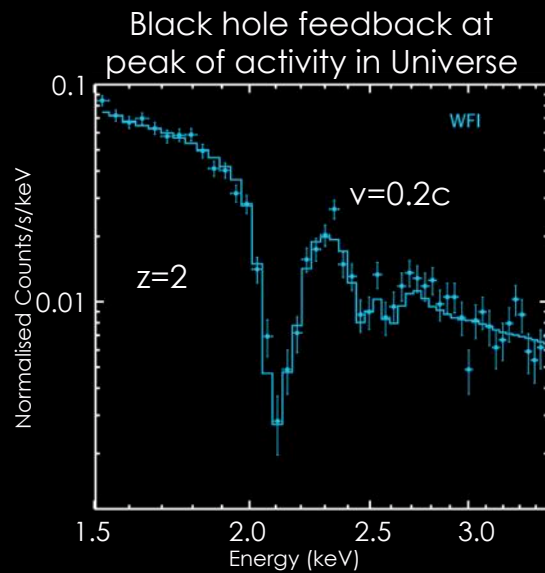
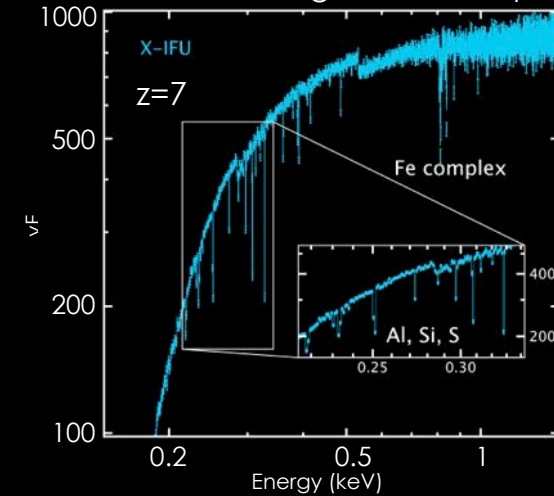

Obscured black hole in
the early Universe

