

OMEGA ROC chips for photodectors

PSHP 2013 workshop Frascati

Christophe de LA TAILLE
OMEGA microelectronics group
Ecole Polytechnique & CNRS IN2P3
<http://omega.in2p3.fr>

- Mutualized ASIC design team
- 10 research engineers (1 IR0, 2 IR1, 6 IR2, 1CDD), 2 pHD students
- Importance of critical mass for more and more complex circuits
- Cross-fertilization between projects
- Technology transfer via startup WEEROC



- Move to Silicon Germanium 0.35 μm BiCMOS technology in 2004
- Readout for MaPMT and SiPM for ILC calorimeters and other applications <http://omega.in2p3.fr>
- Very high level of integration : System on Chip (SoC)

Chip	detector	ch	DR (C)
MAROC	PMT	64	-2f-50p
SPIROC	SiPM	36	+10f-200p
SKIROC	Si	64	+0.3f-10p
HARDROC	RPC	64	-2f-10p
PARISROC	PM	16	-5f-50p
SPACIROC	PMT	64	-5f-15p
MICROROC	μMegas	64	-0.2f-0.5p

MAROC3

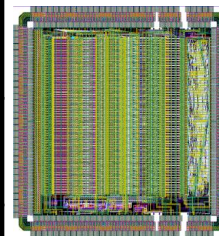

HARDROC2

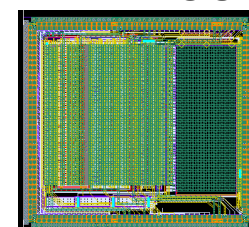

MICROROC1

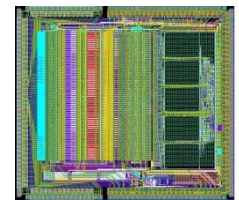

SKIROC2

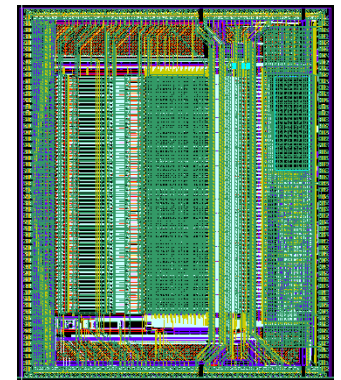

SPIROC2

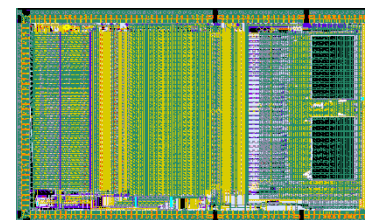

SPACIROC

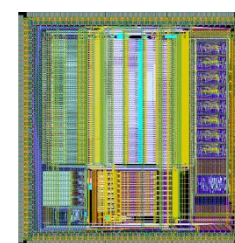

PARISROC2

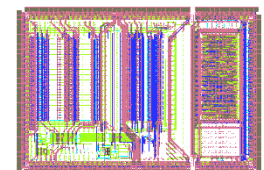

- **Started with OPERA_ROC (2001)**

- 32 Channels in BiCMOS 0.8 μm
- 3000 chips produced in 2002
- Readout OPERA Target tracker in Gran Sasso

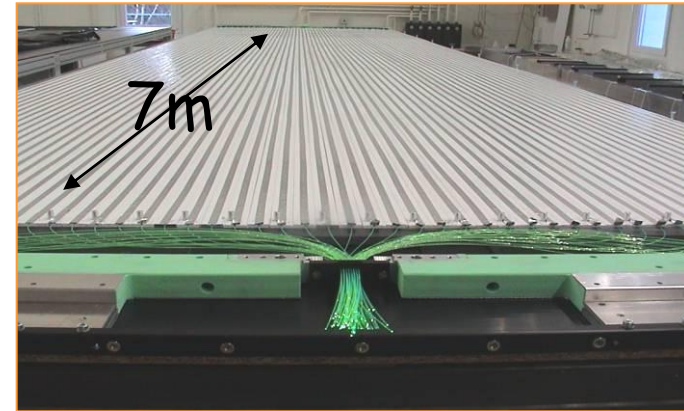

- **MAROC1 (2004)**

- First prototype with 64 channels
- AMS SiGe 0.35 μm (12 mm^2 , $P_w=5$ mW/ch)

- **MAROC2 (2006)**

- 1000 chips produced and bonded on a compact PCB for ATLAS luminometer (ALFA)

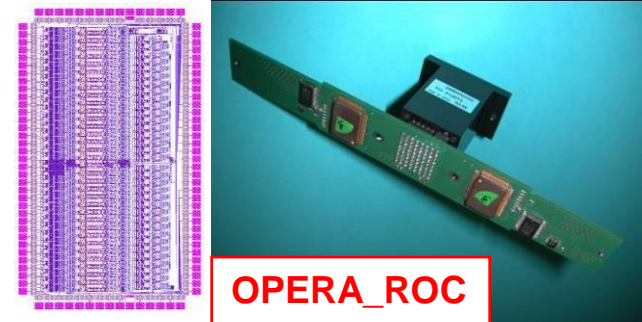

- **MAROC3 (2009)**

- Lower power dissipation
- Wilkinson ADC added
- 1000 chips produced in 2010

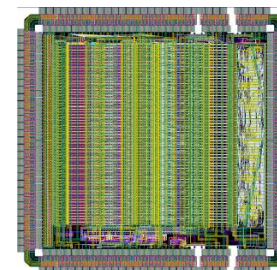

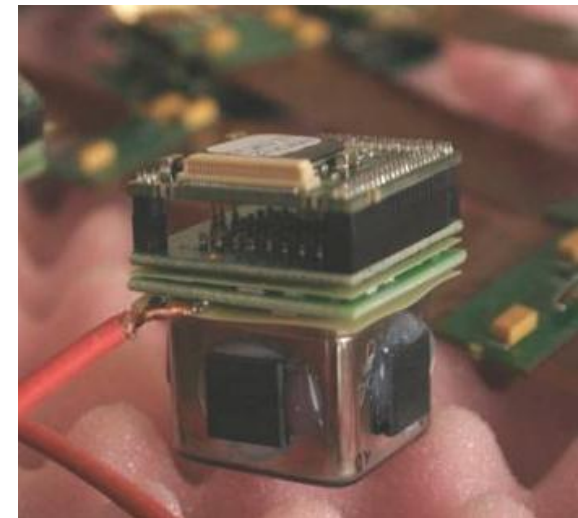
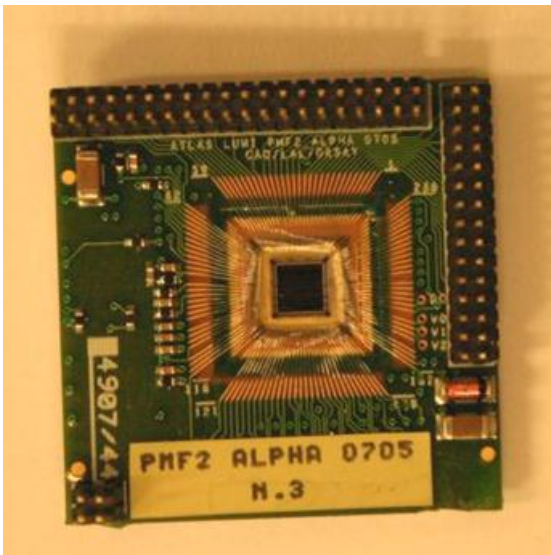
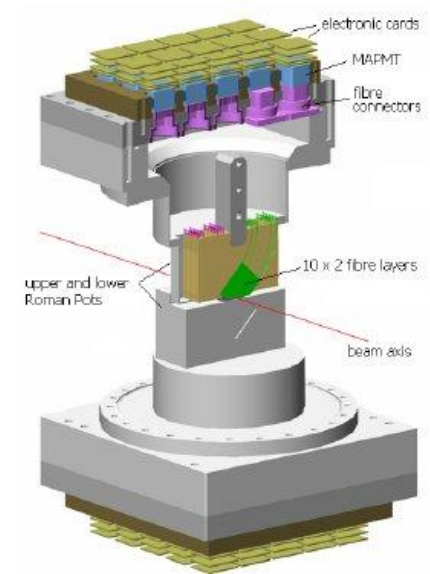
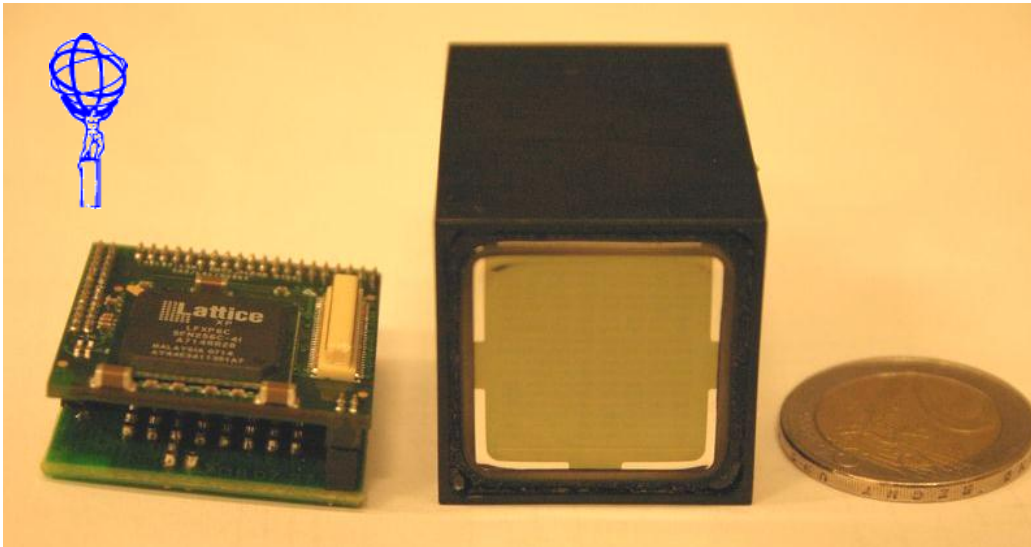

MAROC : MultiAnode Read-Out Chip



- Complete front-end chip for 64 channels multi-anode photomultipliers
 - 6bit-individual gain correction
 - Auto-trigger on 1/3 p.e. at 10 MHz
 - 12 bit charge output
 - SiGe 0.35 μm , 12 mm², Pd = 5 mW/ch
- Bonded on a compact PCB (PMF) for ATLAS luminometer (ALFA)
- Also equips Double-Chooz, medical imaging...
- 3000 chips produced

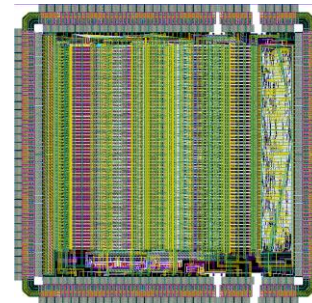
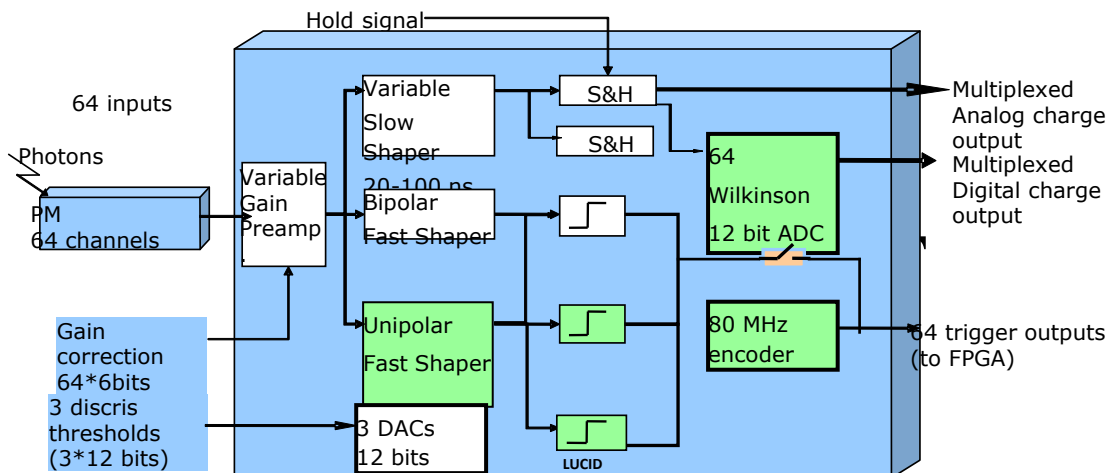
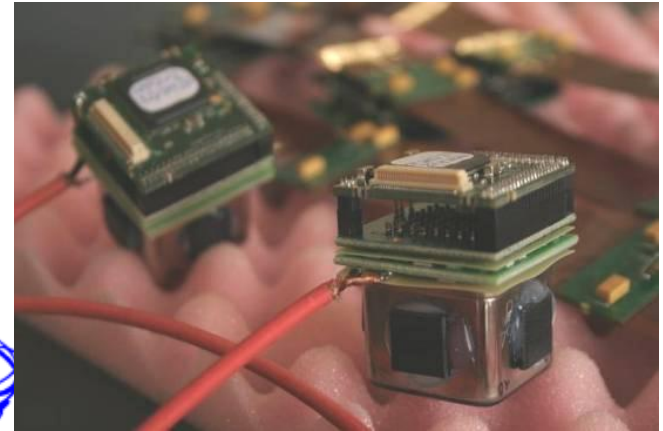

13 nov 2013

CdLT OMEGA ROC chips PSHP2013

MAROC3 overview

1 MUX charge output

AMS SiGe 0.35 μ m
Package: CQFP240
Area: 16 mm²

64 PM inputs

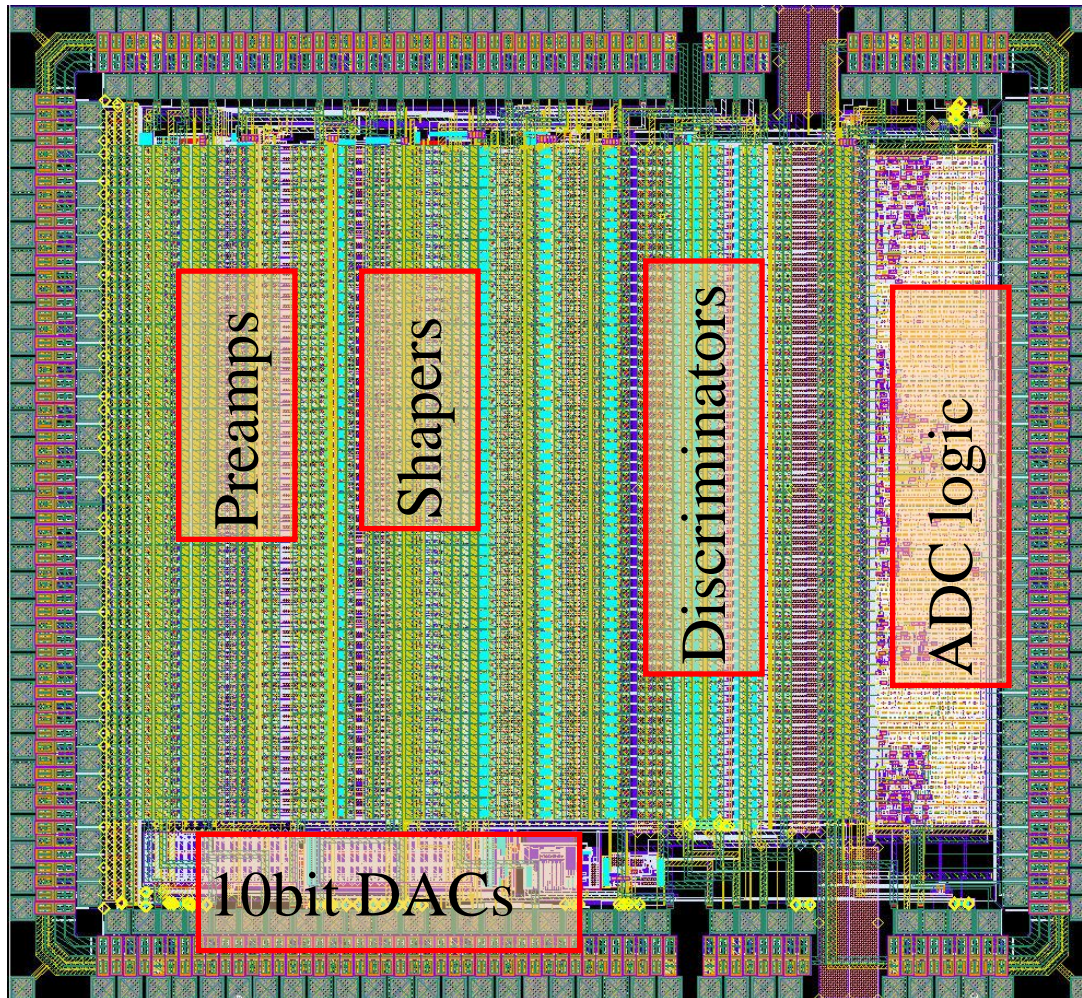

64 trigger outputs

2 Fast OR
outputs

MAROC 3 – Main Features

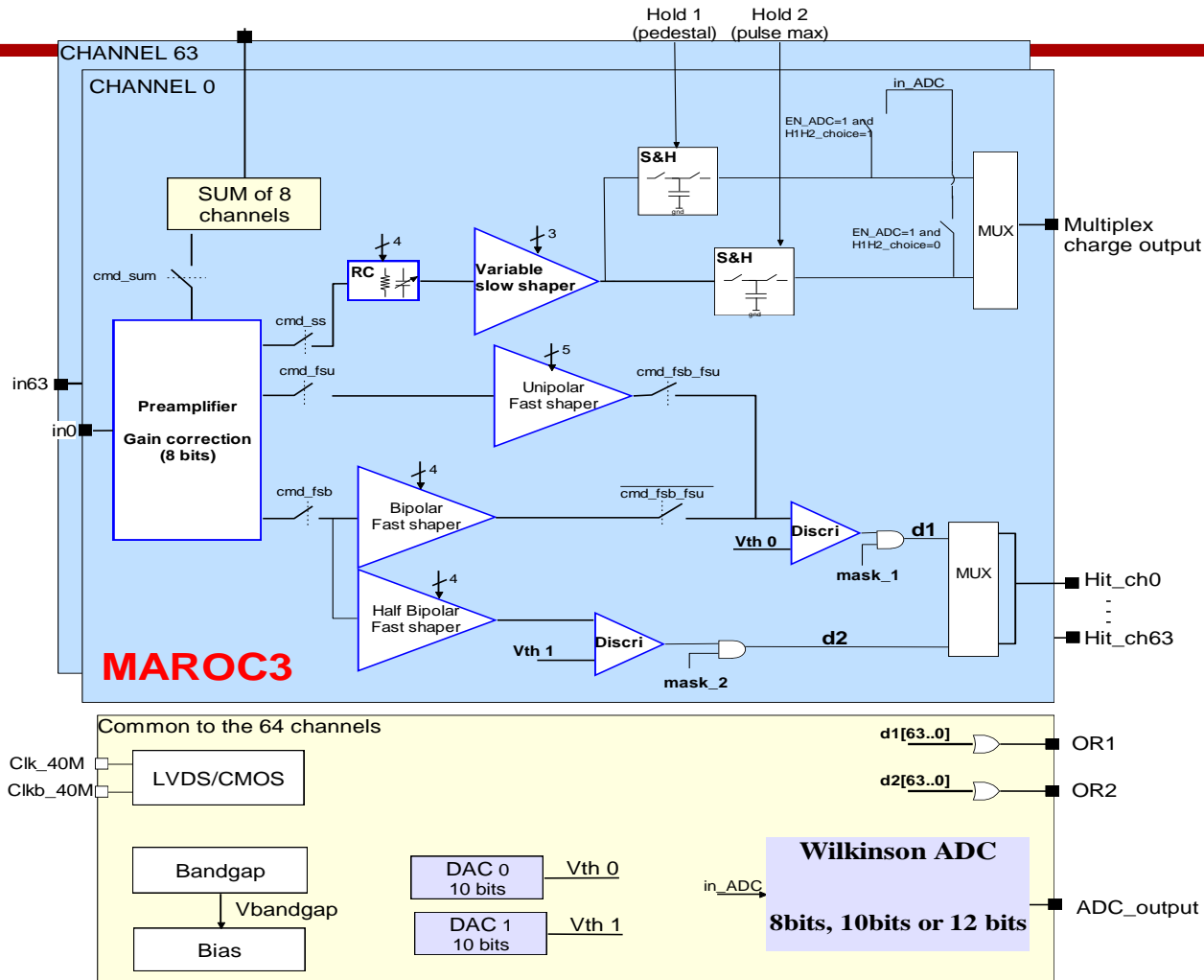

- **Almost pin/pin compatible**
- **Internal reference**
- **Gain adjustment:**
 - 8 bits (2,1,...,0.0156) instead of 6 bits (2,1,...,0.0625)
- **Charge measurement**
 - Variable charge gain
 - Dynamic range increased
 - 8 or 10 or 12 bits wilkinson ADC
- **Trigger measurement**
 - Bipolar fast shaper: 2 thresholds
 - Only 2 DAC
 - Mux instead of an encoder
 - 2 OR outputs
 - New digital output levels: Vhigh and Vlow
 - Mask

Technology: AMS SiGe 0.35 mm

Package: CQFP240

Area: 16 mm²

Power consumption: 220mW (→ 3.5mW/channel)

13 nov 2013

PSHP2013

MAROC 3: Trigger performance



- 50% trigger efficiency:

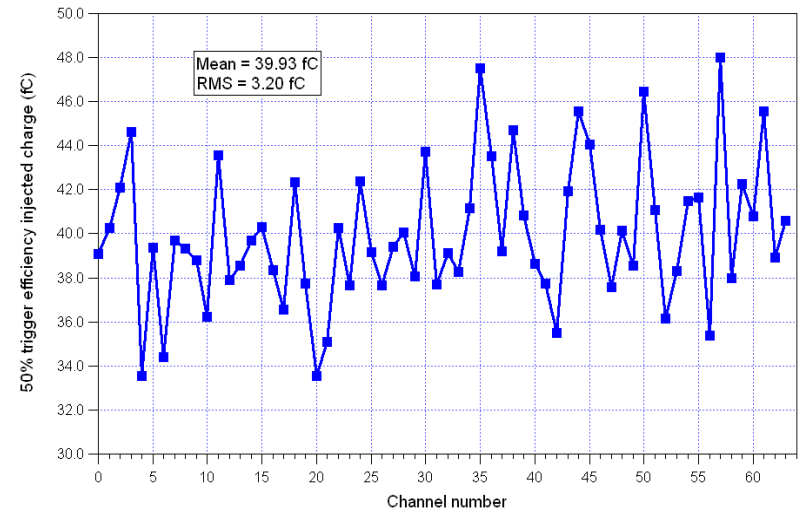
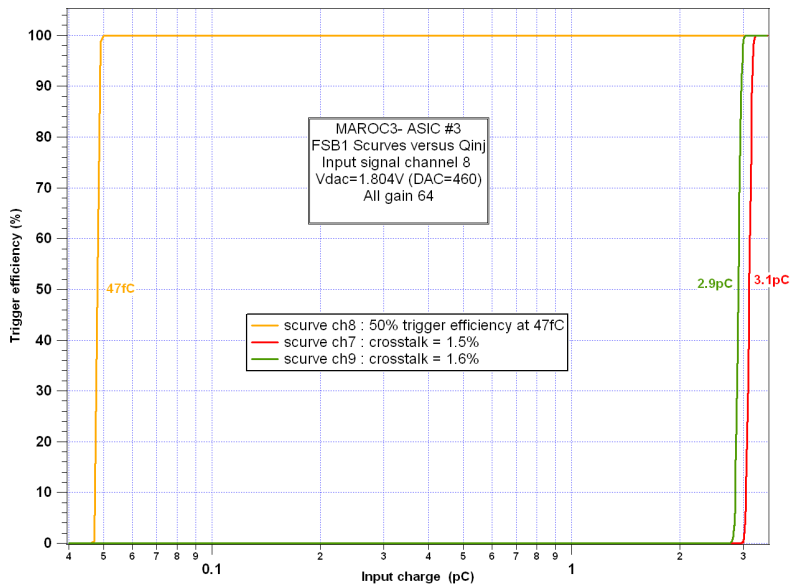
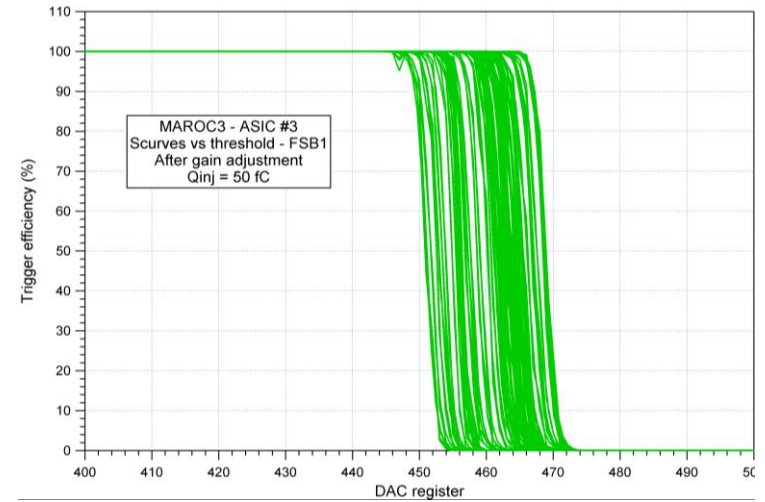
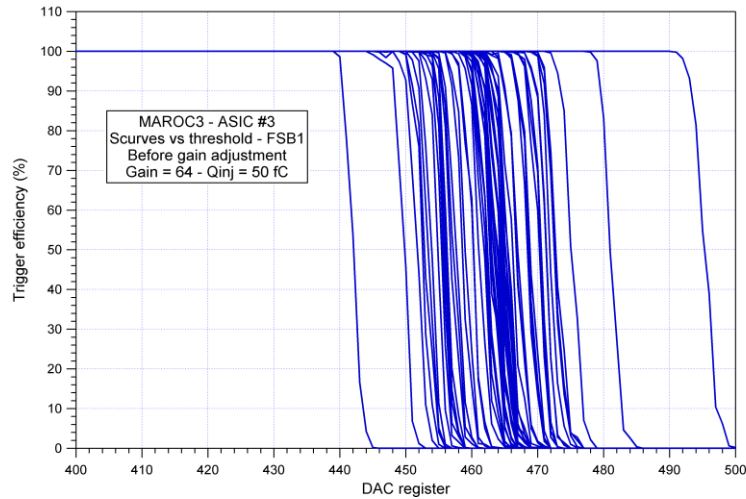

Threshold linearity and uniformity

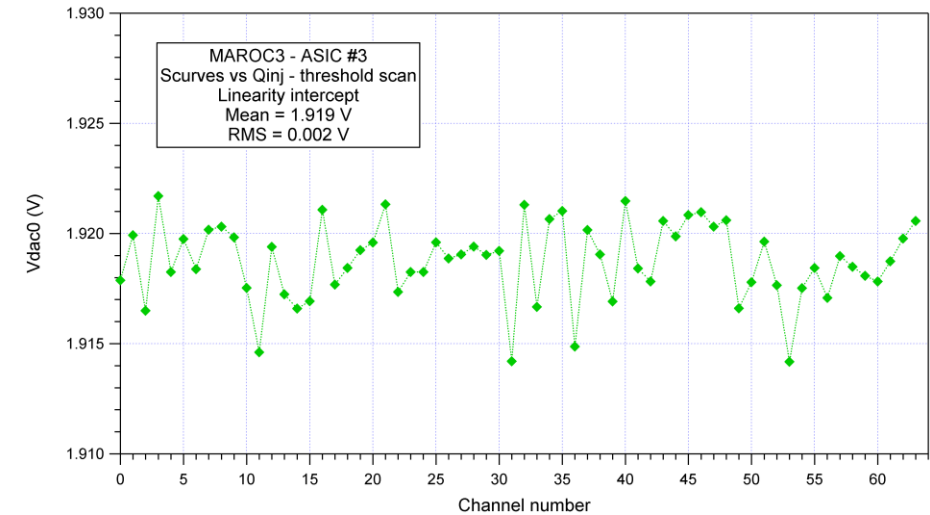
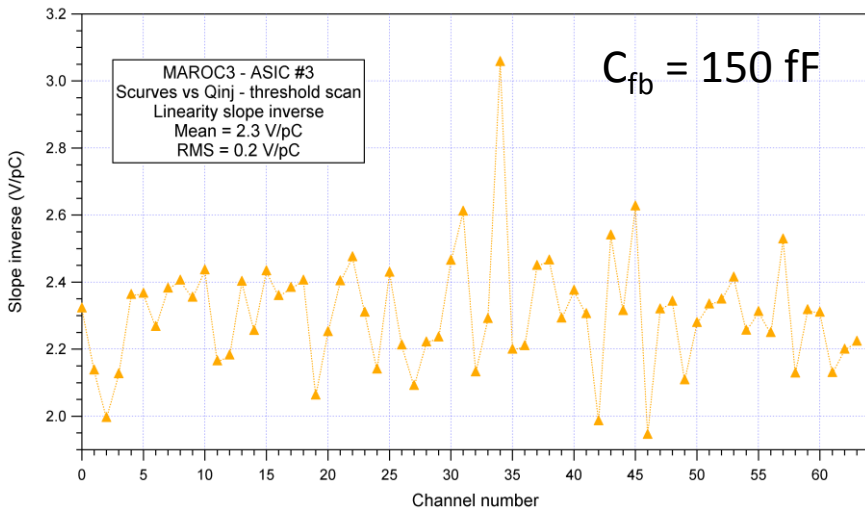
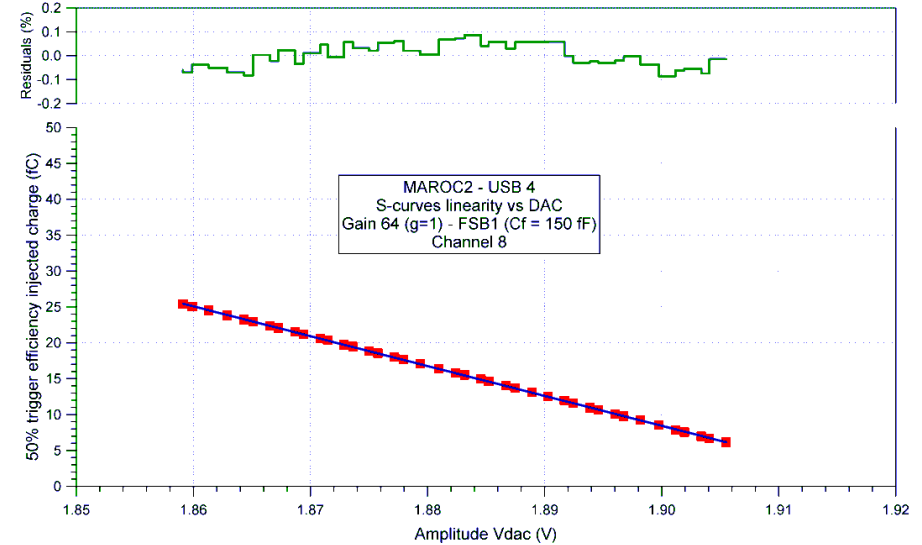
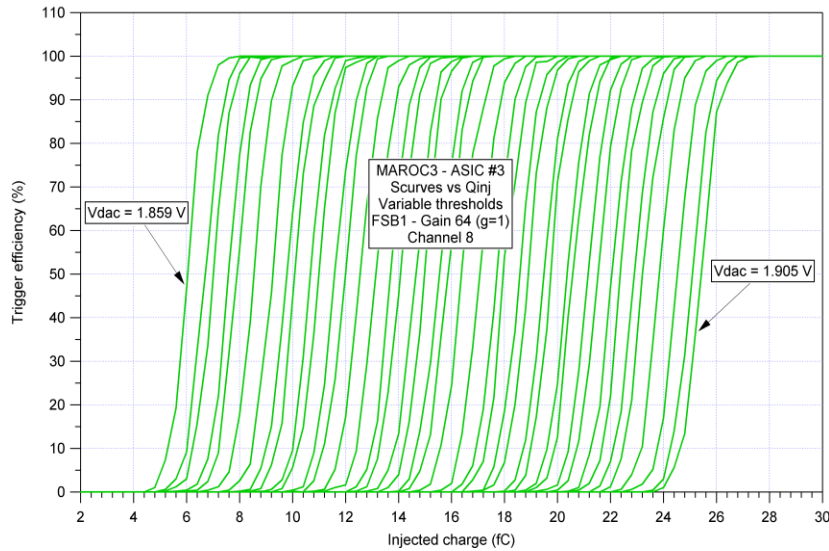

MAROC3 trigger timing resolution

- Testpulse measurement
- Threshold : 50 fC (1.3 pe)

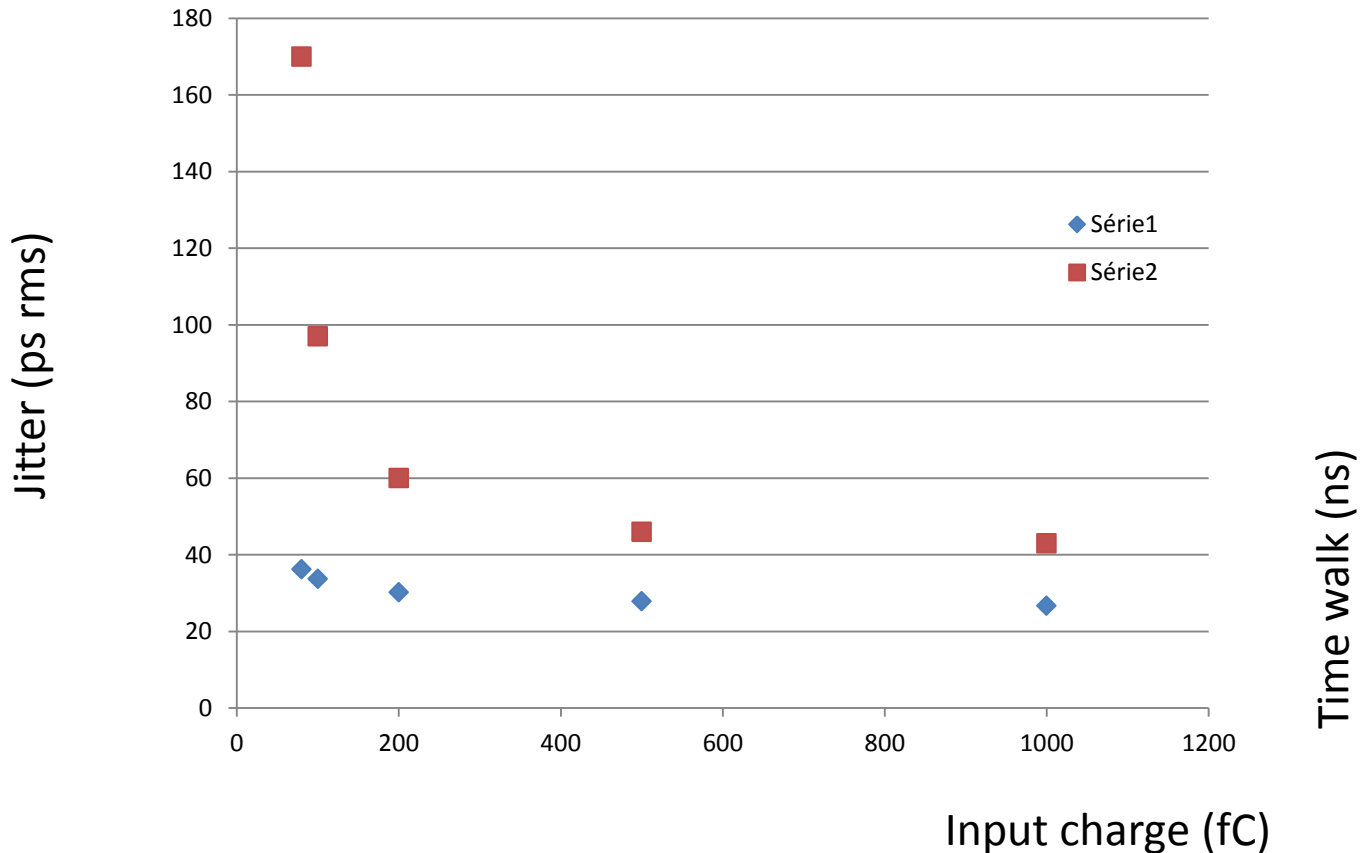

Charge measurements with wilkinson ADC

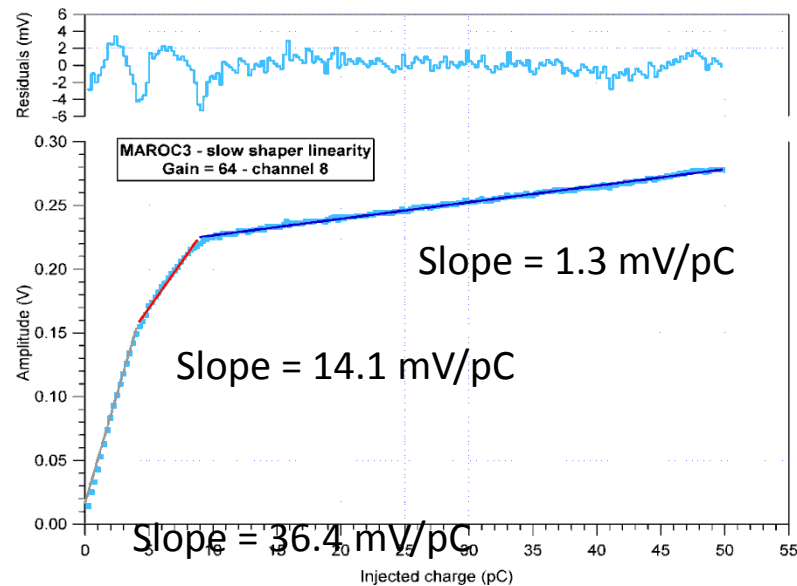
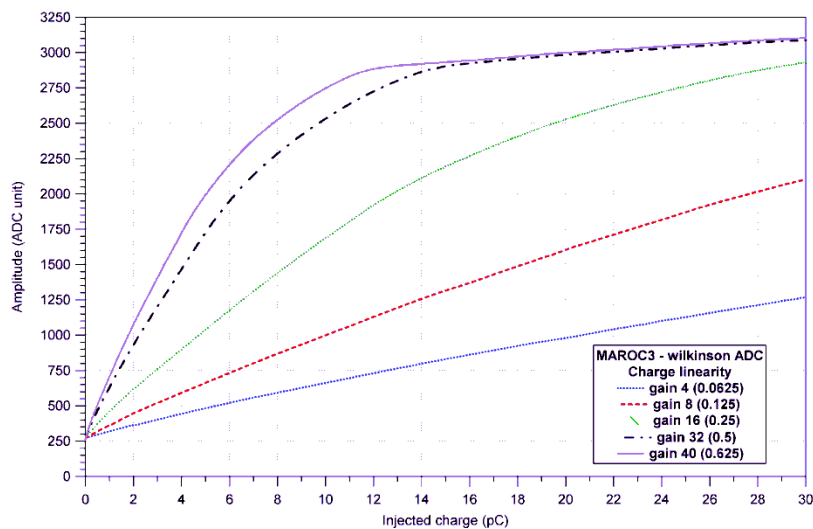
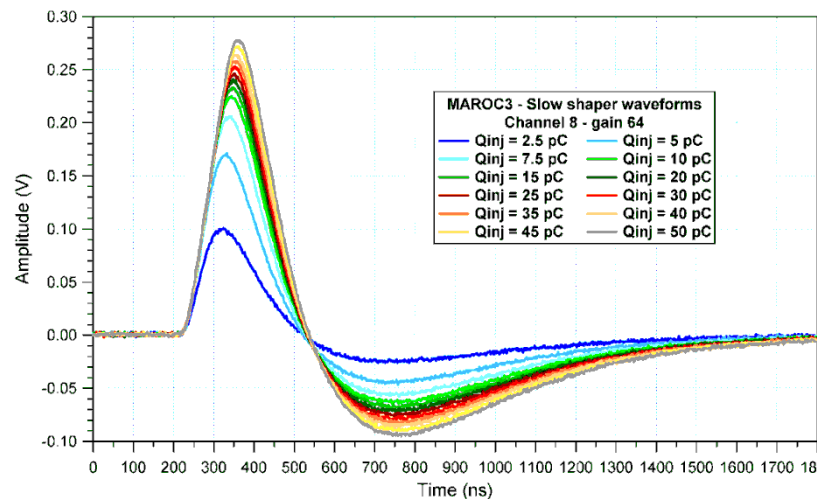
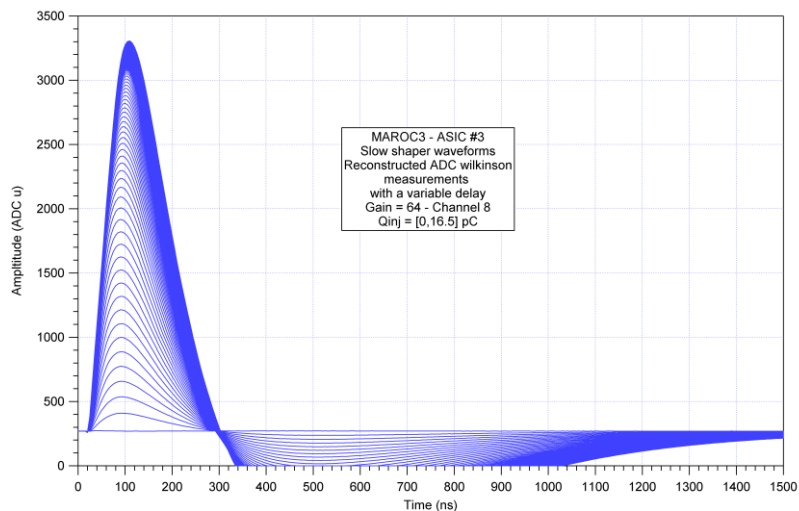

Variant: SPACIROC



JEM EUSO experiment

Analog Front End similar to MAROC
64 channels

Photoelectron counting (<math><50\text{MHz}</math>)

Time Over Threshold
(collab. JAXA/Riken/Konan University)

Digital part : Digitization, memorization

Power consumption <math>< 1 \text{ mW/ch}</math>

data flow ~ 384 bits / 2.5 μs

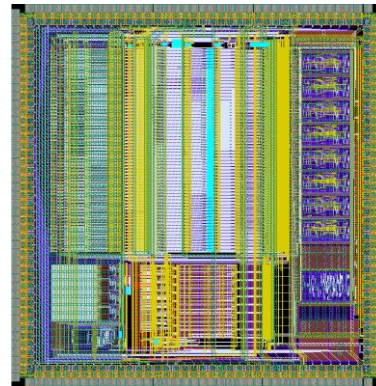

SPACIROC : 16mm²

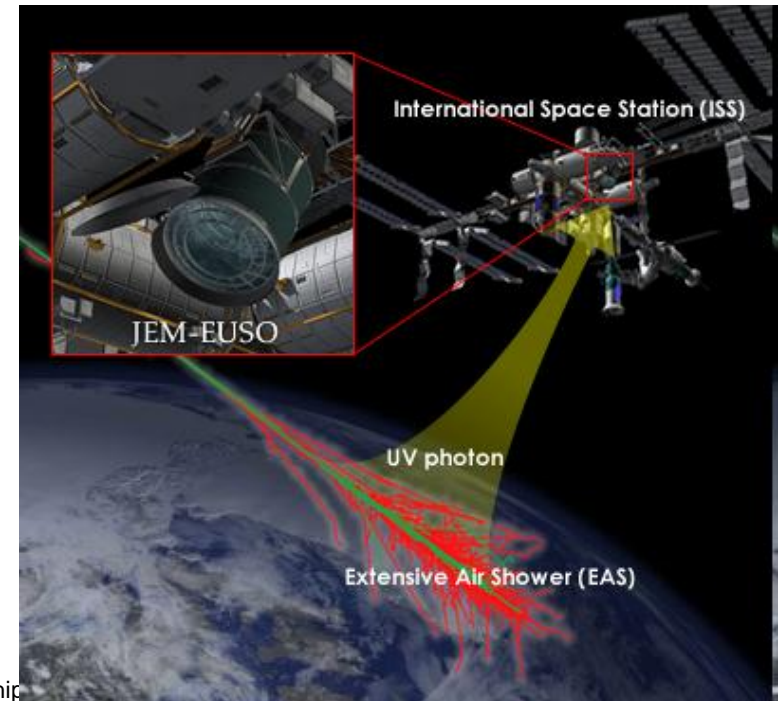
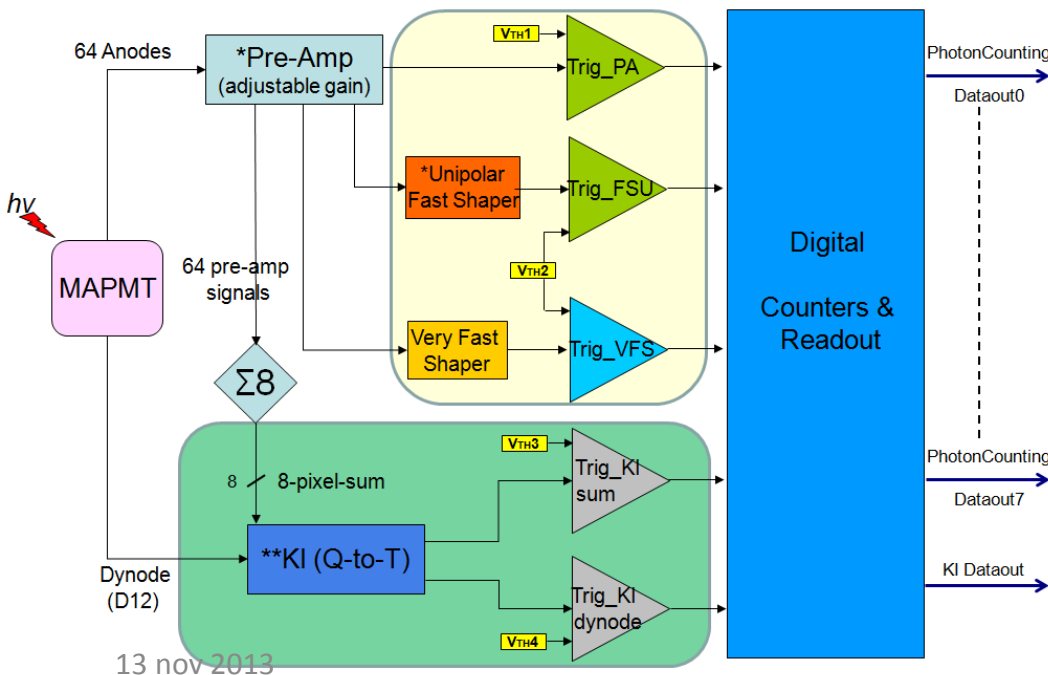

SPACIROC2 measurements

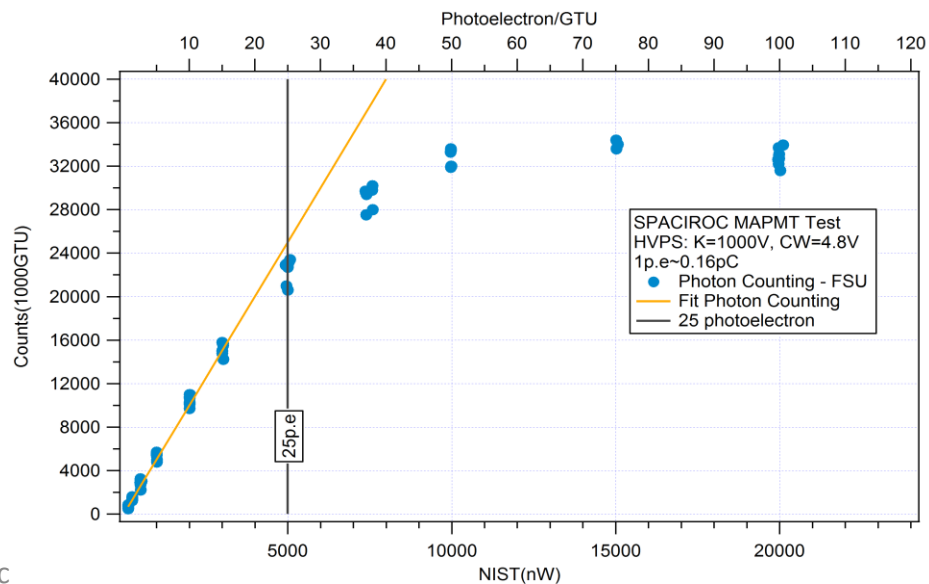
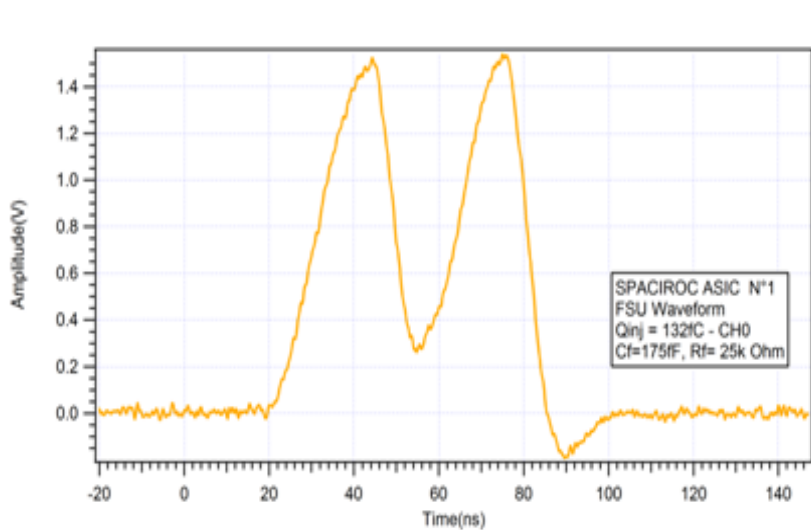
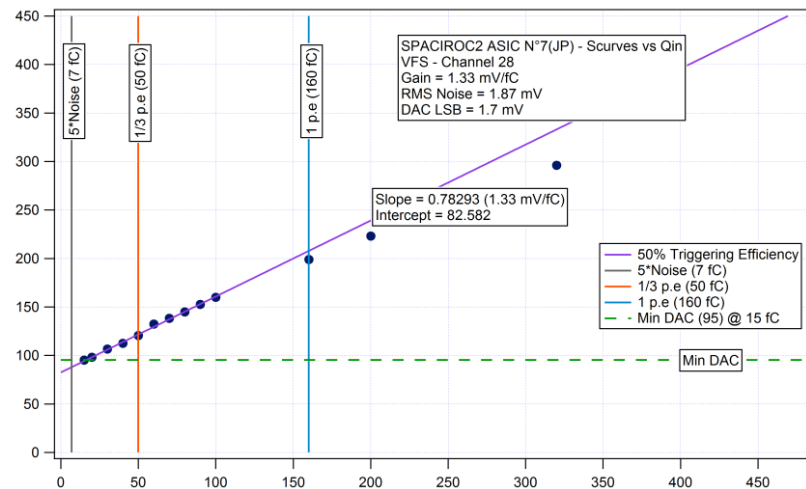
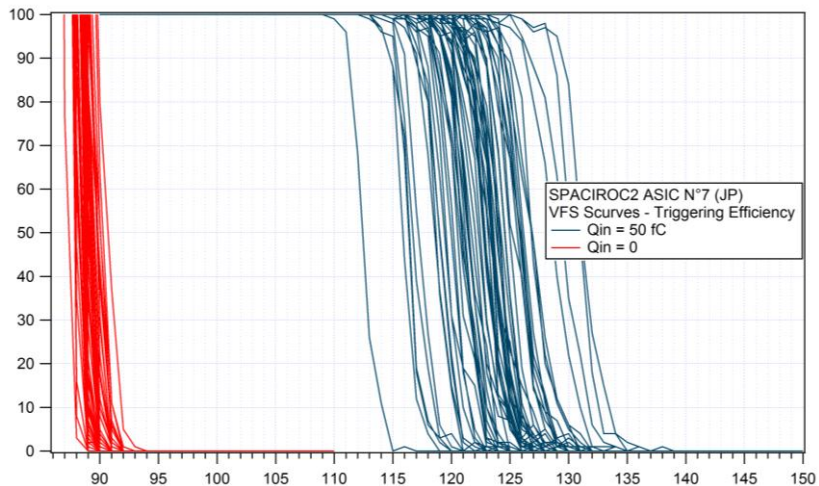

SPIROC for SiPM readout

- **SPIROC : Silicon Photomultiplier Integrated Readout**
 - Developed to read out the analog hadronic calorimeter
 - DESY collaboration (EUDET project)
 - Chip embedded in detector : **low power !**
- **36 channels autotrigger 15bit readout**
 - Energy measurement : 15 bits in 2 gains
 - Autotrigger down to $\frac{1}{2}$ p.e.
 - Time measurement to ~ 1 ns
 - Power dissipation : $25\mu\text{W}/\text{ch}$ (power pulsed)



(0.36m)² Tiles + SiPM + SPIROC (144ch)

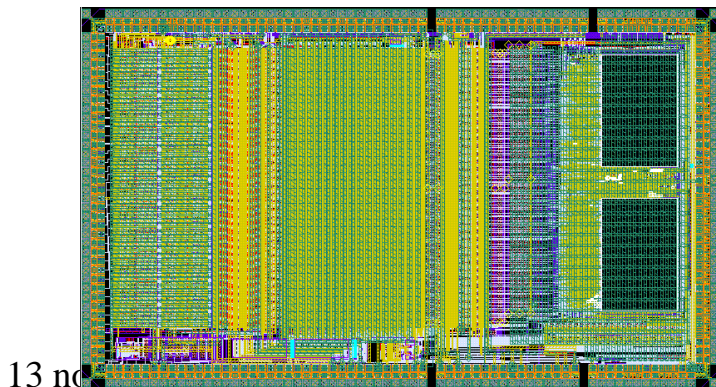

OMEGA R
PSHP201

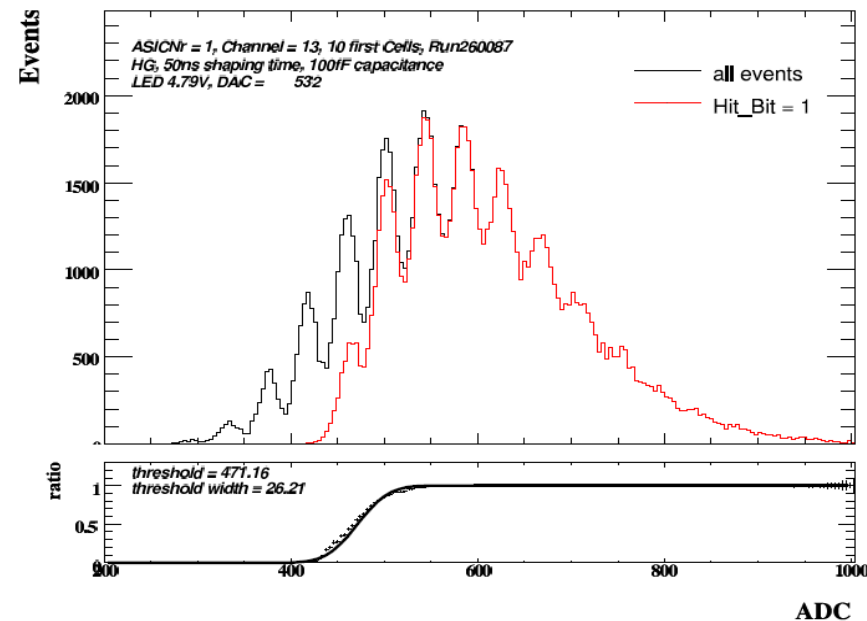

SPIROC : One channel schematic

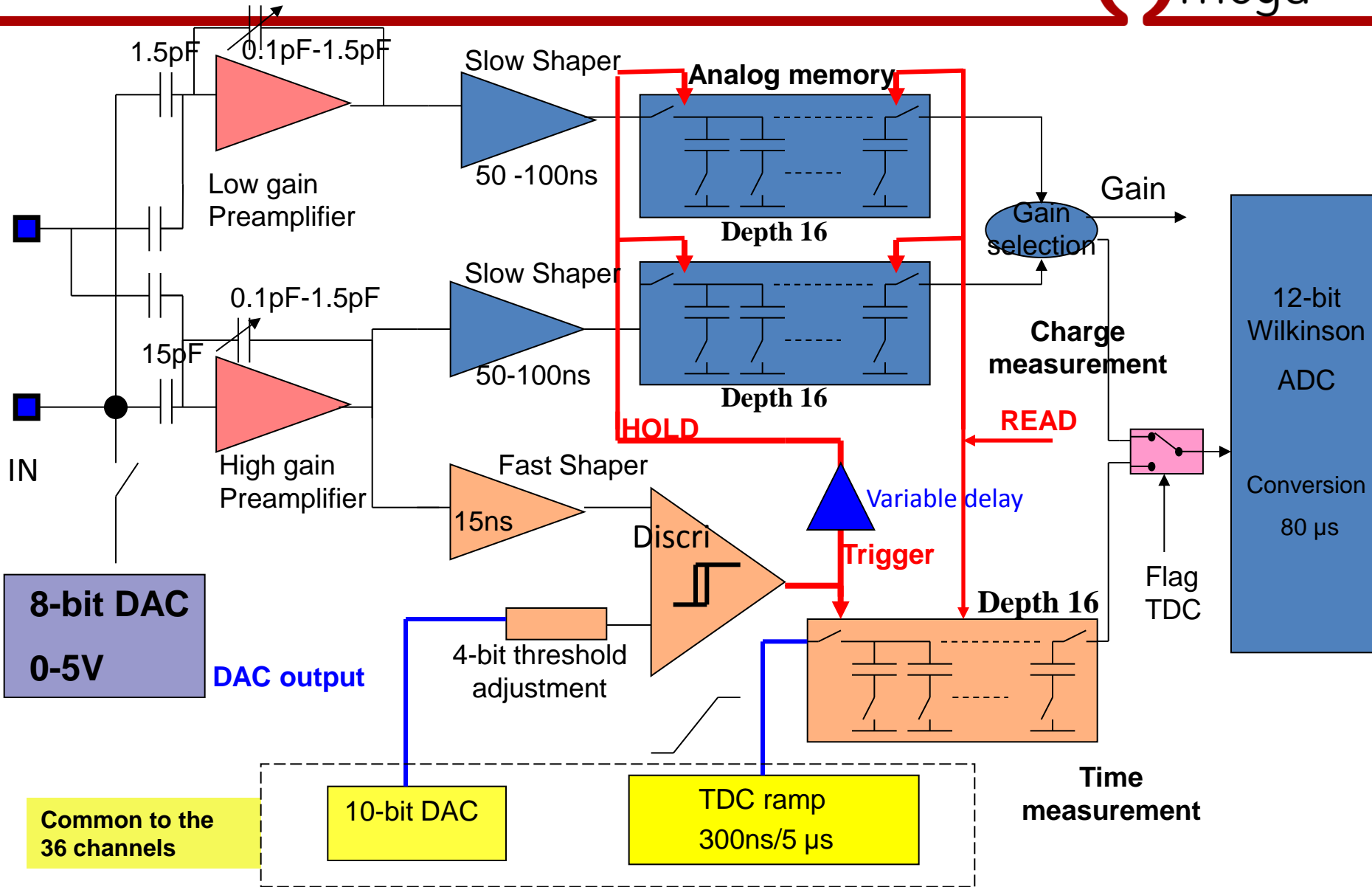

SPIROC measurements

36-channel S-curves: trigger efficiency versus threshold (1 LSB = 2 mV)

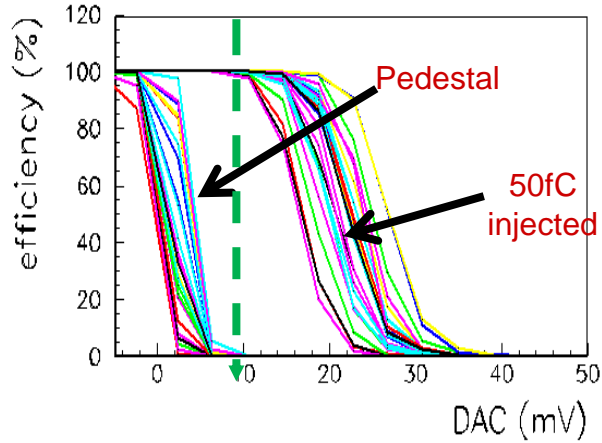

50 % Trigger efficiency point vs Q_{inj}

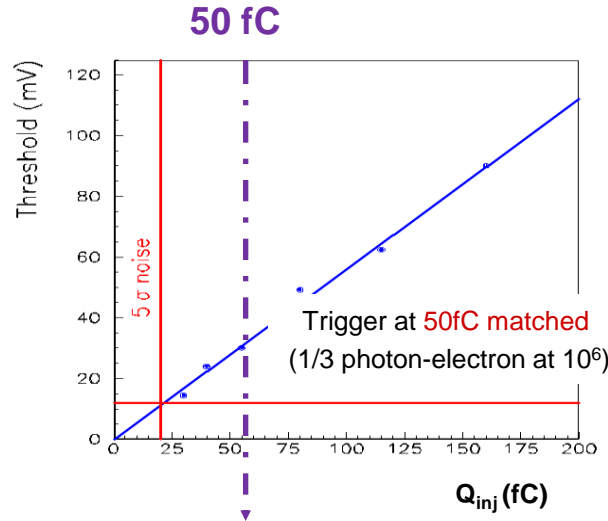

SIPM SPECTRUM with Autotrigger

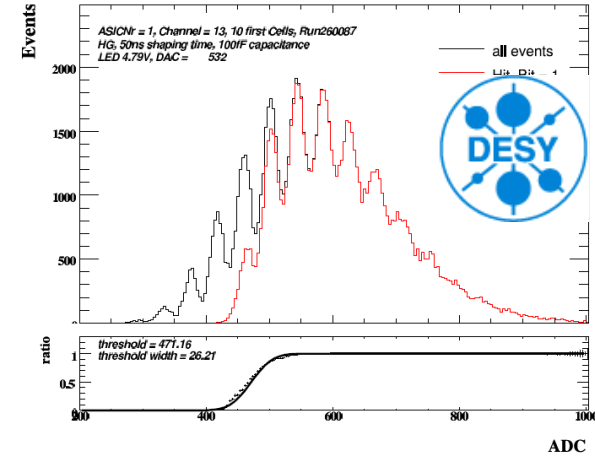

MIP response in DESY
6 GeV electron testbeam

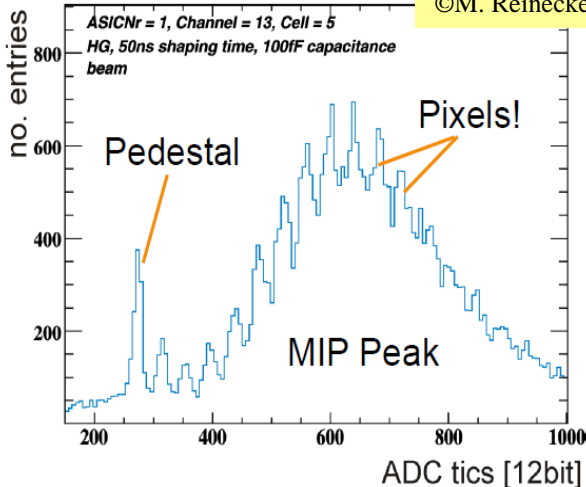

©M. Reinecke (DESY)

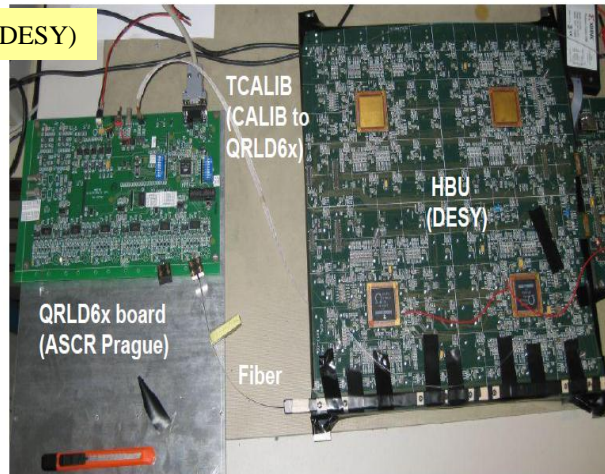

linearity using the auto gain mode and internal ADC

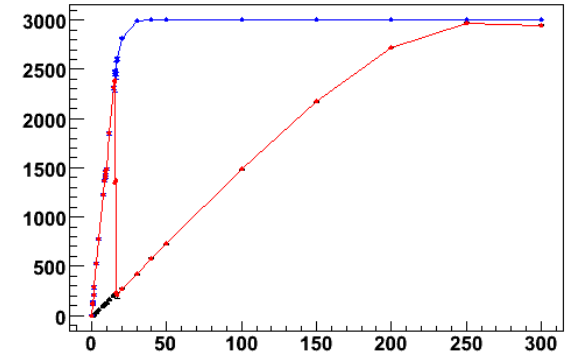

EASIROC: SIMPLER VERSION OF SPIROC

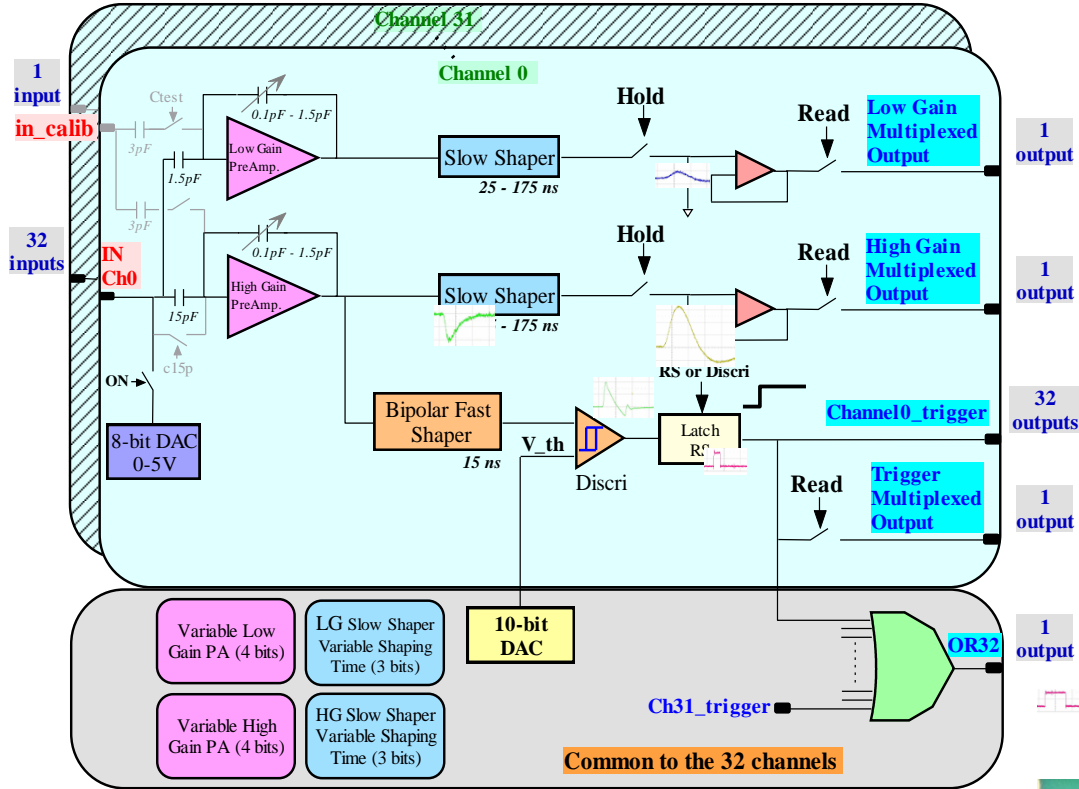

- **32-channel front-end readout (analogue part of SPIROC)**
 - 2 multiplexed analog outputs (high gain, low gain) [tri state outputs]
- **Trigger output**
 - 32 Trigger outputs
 - OR32 output
 - Trigger multiplexed output (latch included) [Tri state output]
- **Low power : 4.84 mW/channel, 155 mW/chip**

SipMed, IMNC, LAL, OMEGA

Many applications:

- Astrophysics (CTA Palermo),
- Nuclear physics (KEK, Tohoku),
- PET (Roma, Pisa, Valencia),
- Vulcanology (Napoli, IPN Lyon)



JPARC

- 16 channels, prototyping ASIC
- 16 discriminator output, 16 charge output, MUX charge output, Trigger OR
- Power consumption **3.5mW/ch**
- RF, common emitter SiGe fast amplifier, DC coupled to detector, **GBWP 10GHz@1mW**
- Fast SiGe discriminator, **BW 1GHz @ 1.5mW**
- Low noise amp+shaper for charge measurement
 - Adjustable peaking time (25ns, 50ns, 75ns, 100ns)
 - Low gain for high swing (up to 3000pe) : 360uV/pe



weeroc

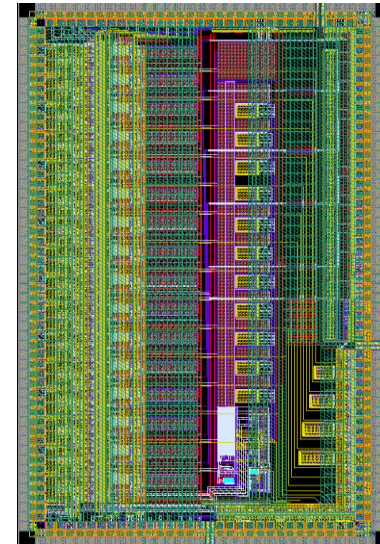
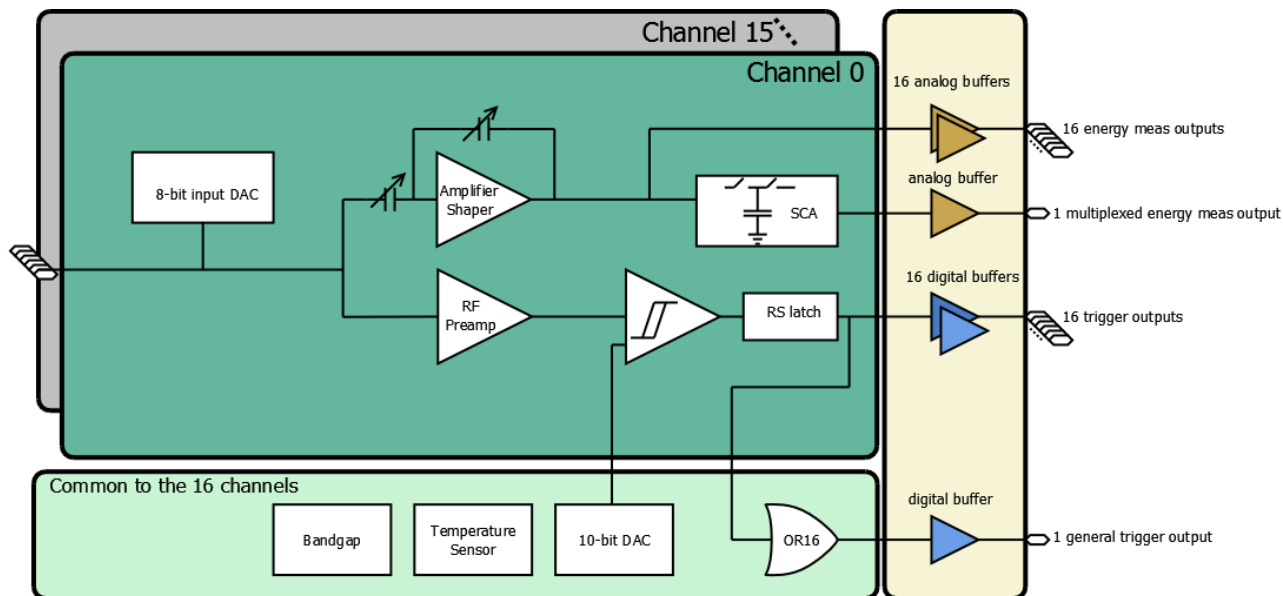

PETIROC measurements with SiPM

- **1x1mm SiPM Hamamatsu**
- **Laser for low light injection**
 - 405nm, Jitter : 28 ps FWHM
- **Low trigger mandatory for good timing resolution**
- **Petiroc can trigger on first photoelectron**
- **Petiroc is low noise : single photon identification**

10 pe laser injection
preamp out

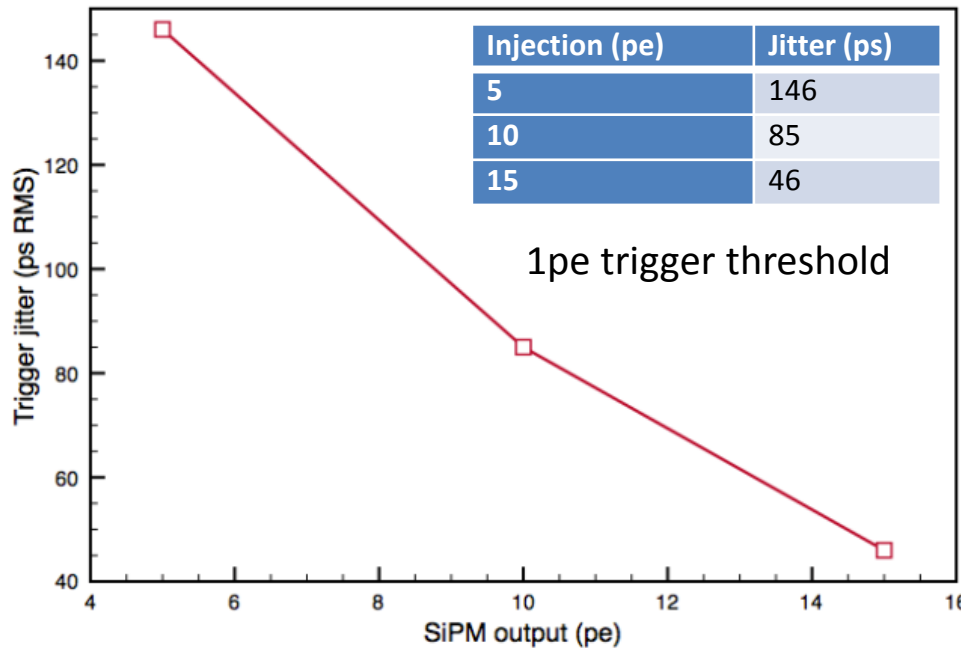
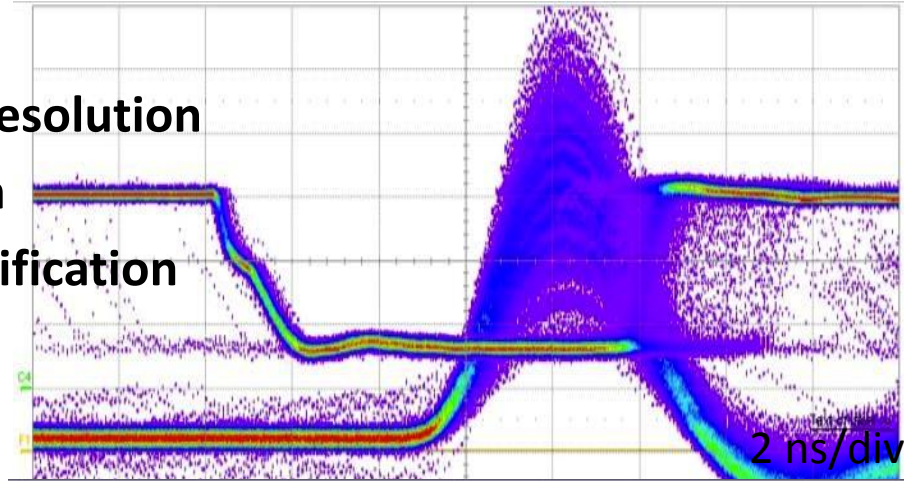

10 pe laser injection
threshold 0.5pe
amp + trigger

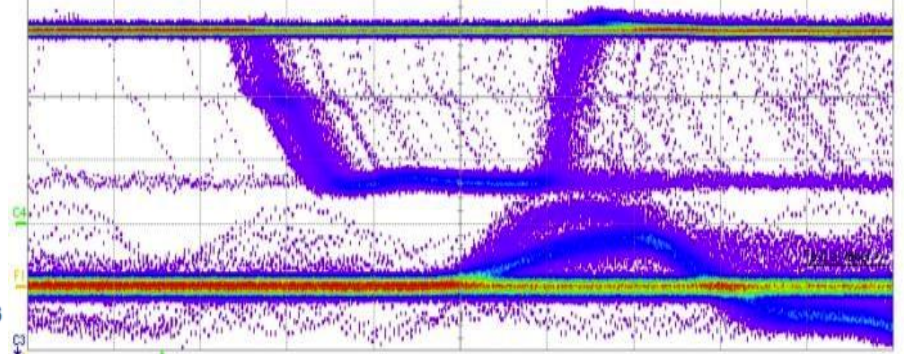

• Photomultiplier ARray Integrated SiGe Read-Out Chip

- Replace large PMTs by arrays of smaller ones (PMm2 project)
- Centralized ASIC 16 independent channels
- Auto-trigger at 1/3 p.e.
- Charge and time measurement (10-12 bits)
- Water tight, common high voltage
- Data driven : « One wire out »

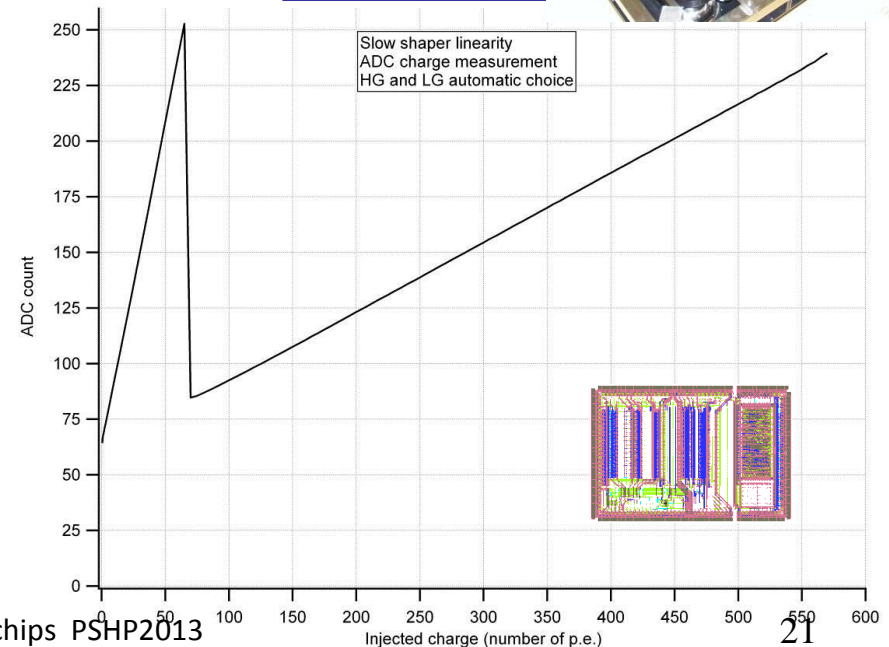
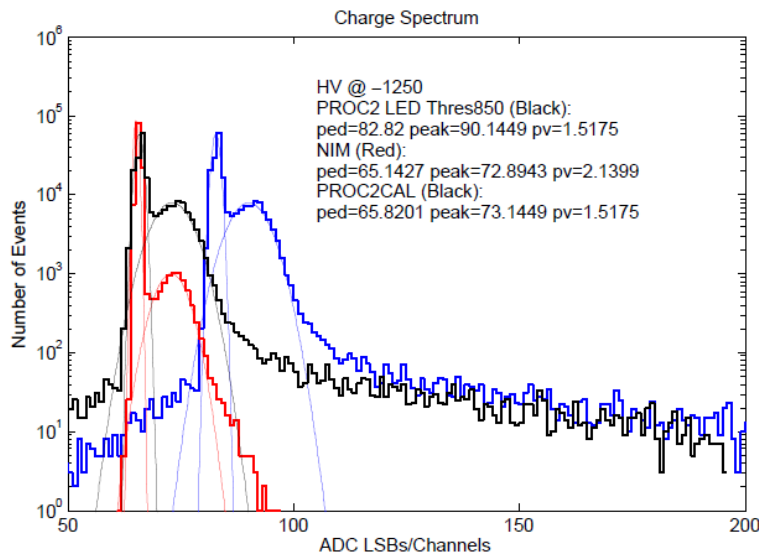
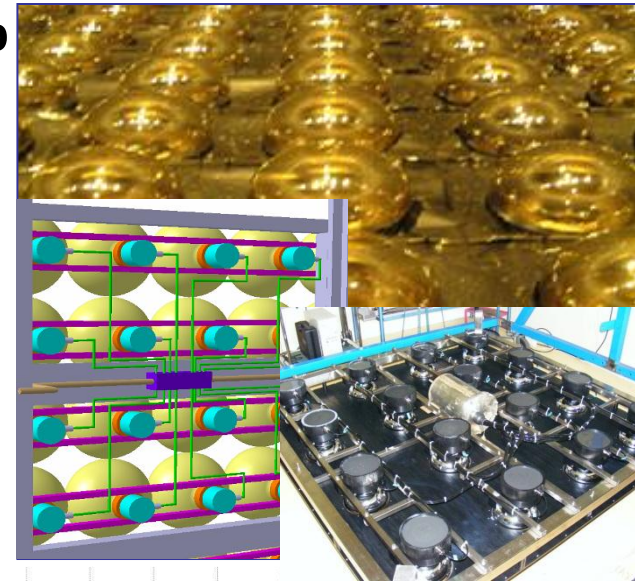

13 nov 2013

Figure 3.3.4: The calibrated of different acquisition system

PARISROC: System On Chip

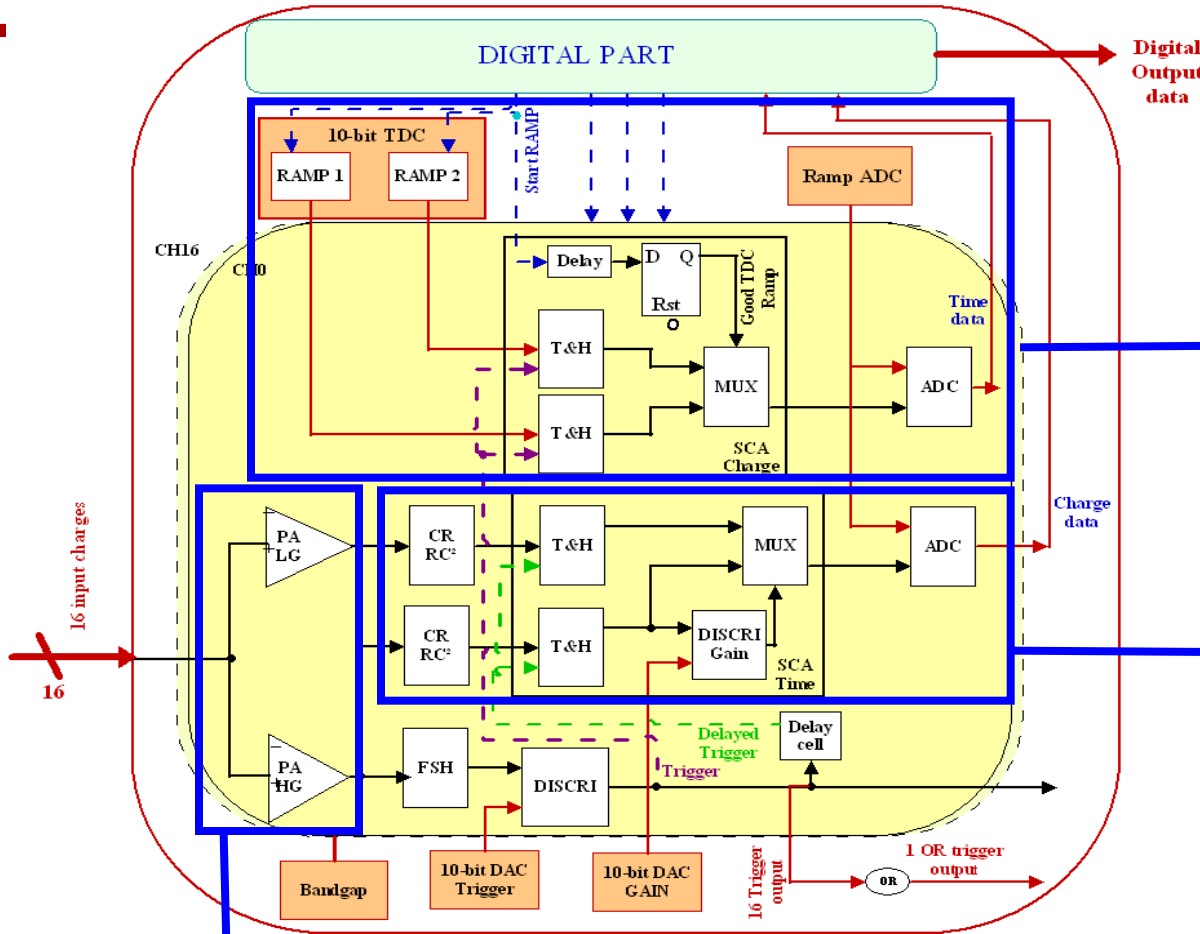

Time measurements

2 systems:

1. Coarse time by 24-bit gray counter (Digital part)
 - working at 10 MHz
 - with 1.67 s of dynamic
 - 100 ns steps
2. Fine time by analog TDC
 - ✓ 100 ns dynamic range
 - ✓ Time resolution: 220 ps
 - ✓ Non linearity: +/- 1ns

Charge measurements

- ✓ Two gain channels to cover the large input dynamic range
- ✓ 2 input preamplifier with adjustable gains (on 8 bits)
- ✓ Shaper with variable shaping time (from 25 ns to 100 ns) and gain
- ✓ Charge resolution: max 0.2 p.e. (32 fC) for 10-bit ADC
- ✓ Dynamic range from 1/3 pe to 600 pe (~ from 50 fC to 100 pC)

Input stage

2 input preamplifiers with adjustable gains (on 8 bits)

- **Production run end 2014 : large quantities, reduced cost**
- **MAROC4 foreseen : now time for requests for new features**
 - Radiation tolerance : triple voting
 - Higher speed
 - Lower power 2mW/ch, power pulsing mode

MAROC, SPACIROC , PARISROC : for PMTs

SPIROC, EASIROC for SiPM

- ✓ **Low power multichannel System on Chips, smart detectors**
- ✓ **Versatility** allows these chips to be used in various applications
 - high energy physics, nuclear physics, medical imaging,



vulcanology...)



MPPC 50ch を用いた小型プロトタイプ

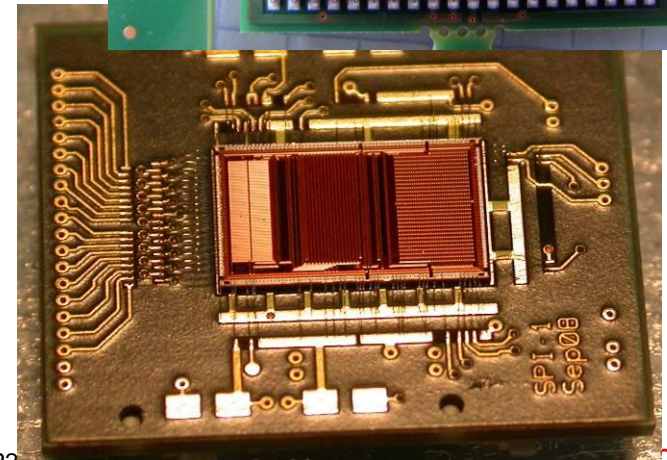
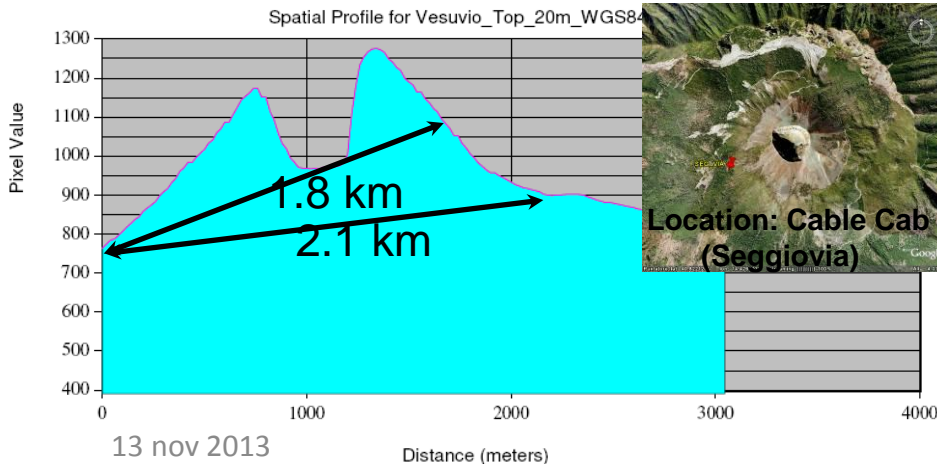
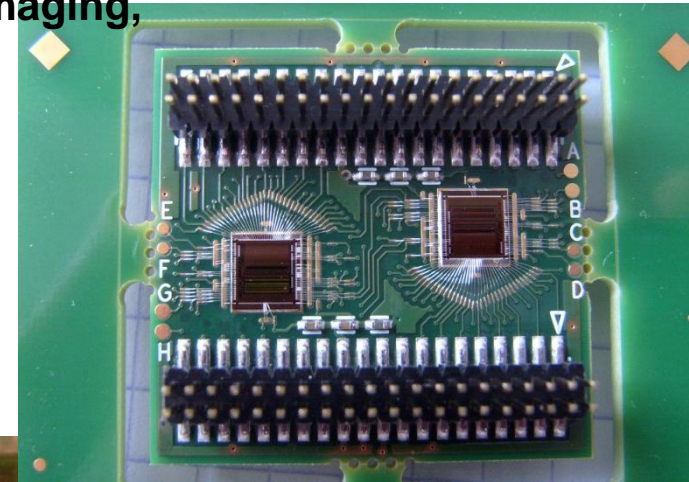

ROC family



	MAROC	SPIROC	EASIROC	HARDROC	MICROROC	SKIROC	PARISROC	SPACIROC
Technology	0.35μ SiGe	0.35μ SiGe	0.35μ SiGe	0.35μ SiGe	0.35μ SiGe	0.35μ SiGe	0.35μ SiGe	0.35μ SiGe
Packages available	•Naked •QFP240	•Naked •TQFP208	•Naked •TQFP160	•Naked •TQFP160	•Naked •QFP160	•Naked •QFP240	•Naked •QFP160	•Naked •CQFP240
Detector compliant	PMT, MAPMT, SiPM, μmegas, RPC	PMT, MAPMT, SiPM, μmegas, RPC, GEM, PIN	PMT, MAPMT, SiPM, μmegas, RPC, GEM, PIN	PMT, MAPMT, SiPM, μmegas, RPC	μmegas	RPC, GEM, PIN	PM matrix	MAPMT
Optimized for	MAPMT	SiPM	SiPM	RPC	μmegas	PIN	PM matrix	MAPMT
Nmber of channels	64	36	32	64	64	64	16	64
Kind of measurement	•Threshold •Charge	•Threshold •Charge •Time	•Threshold •Charge	•Threshold •Charge	•Threshold •Charge	•Threshold •Charge	•Threshold •Charge •Time	•Threshold •Charge
Outputs	64 triggers, 1 mux charge (analogue), 1 mux charge digitized	1 digital formatted output, 1 mux charge (analogue)	32 triggers, 2 mux charge (analogue), 1 mux trigger	1 digital formatted output, 1 mux charge (analogue)	1 digital formatted output, 1 mux charge (analogue)	1 digital formatted output, 1 mux charge (analogue)	16 triggers, 1 digital formatted output, 1 mux trigger	64 triggers, 9 mux charge
Input Polarity	Negative	Positive	Positive	Negative	Negative	Positive	Negative	Negative

Standard testboard

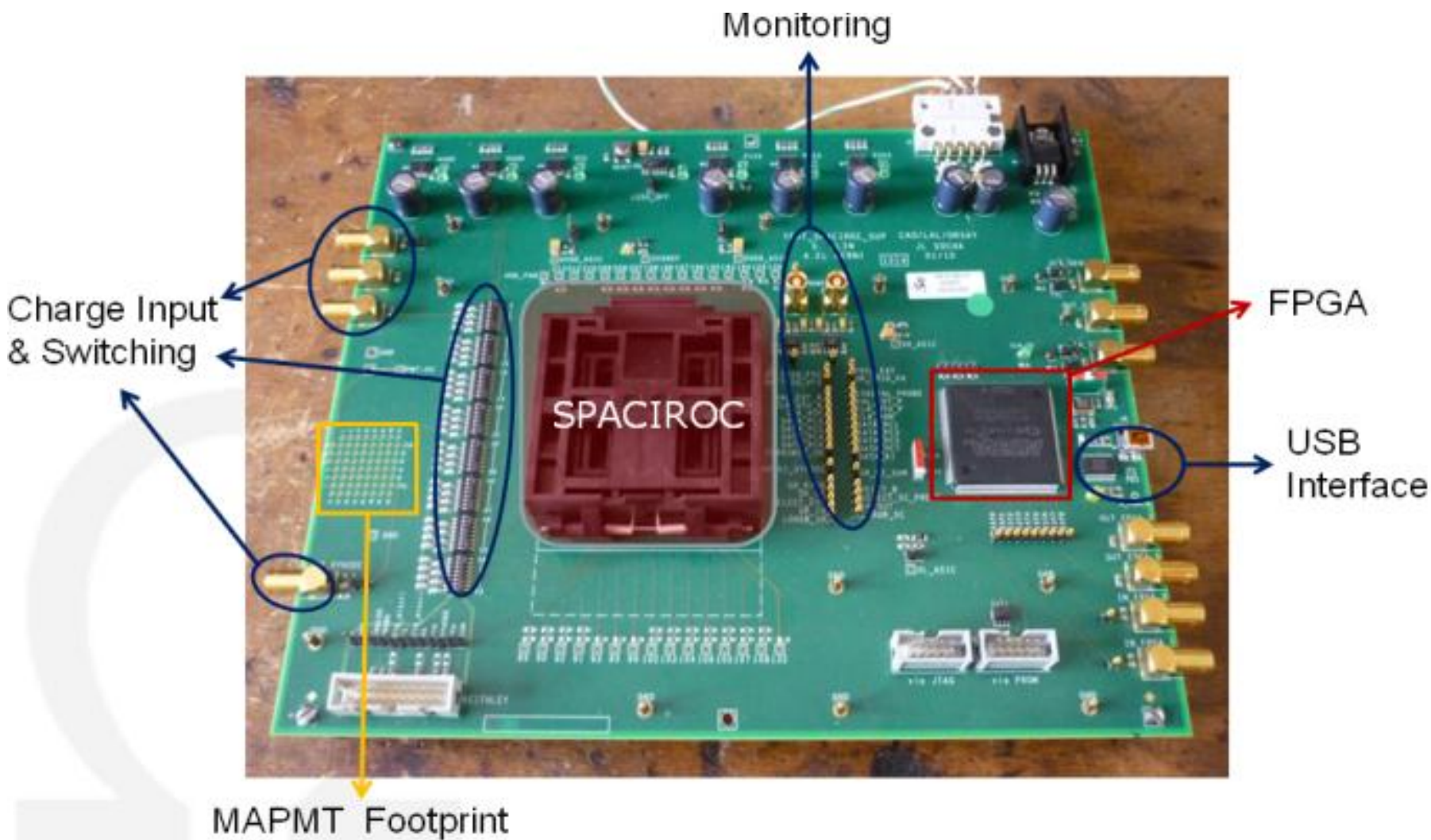

- Pulser vs SiPM comparison
- SiPM is significantly slower than Petiroc
 - Pulser with 100pF injection capacitance, 10pe injected
 - SiPM illuminated with laser pulse, 10pe measured
 - Threshold from 1pe to 9pe
- Petiroc bandwidth meas. : 877MHz with

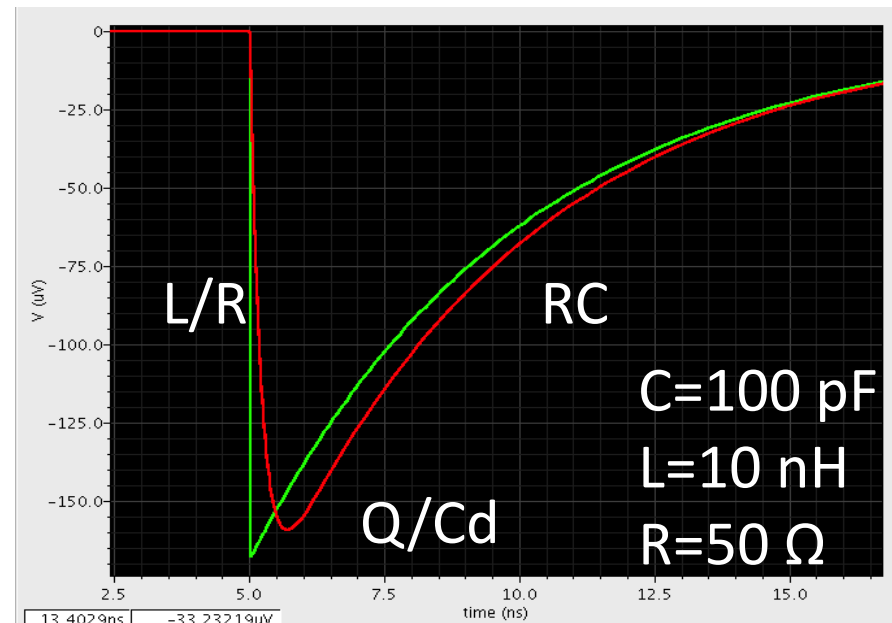
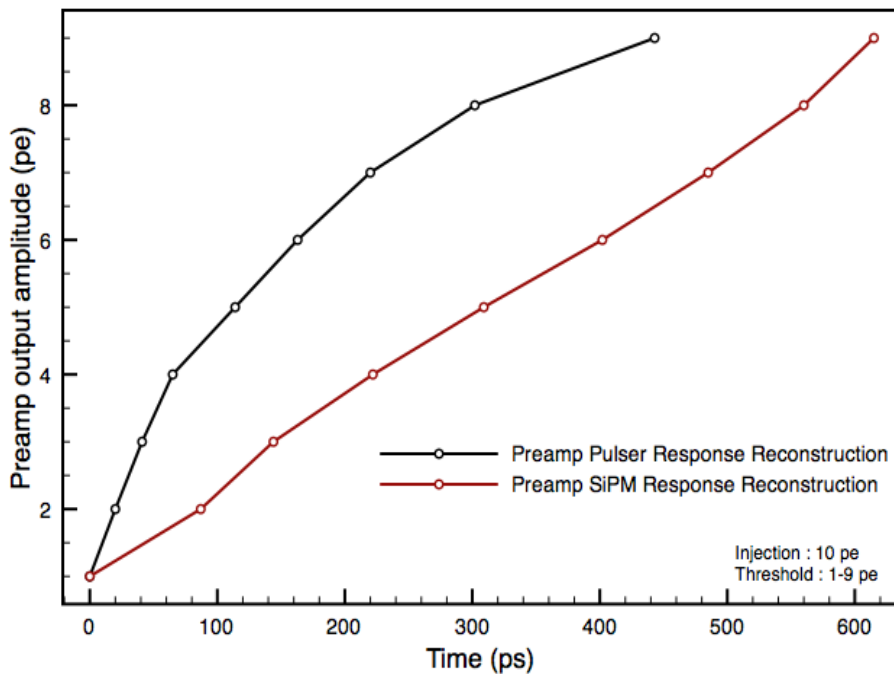
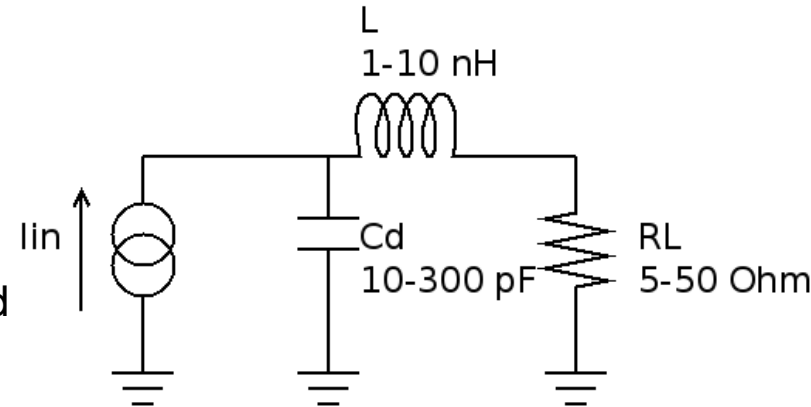

Energy resolution



- Preliminary meas, raw data, no correction for non linearities
- Using 3x3x5mm LYSO:Ce crystal & 3x3mm Ketek SiPM
- Na22 source
- Petiroc self-triggered (threshold 5pe)
- Energy resolution: 9.5% FWHM

