

# IRIDE

## Interdisciplinary Research Infrastructure with Dual Electron linacs&lasers

Massimo.Ferrario@Inf.infn.it  
on behalf of

D. Alesini<sup>1</sup>, M. P. Anania<sup>1</sup>, M. Angelone, D. Babusci<sup>1</sup>, A. Bacci<sup>3</sup>, A. Balerna<sup>1</sup>, M. Bellaveglia<sup>1</sup>, M. Benfatto<sup>1</sup>, R. Boni<sup>1</sup>, R. Bonifacio<sup>7</sup>, M. Boscolo<sup>1</sup>, F. Bossi<sup>1</sup>, B. Buonomo<sup>1</sup>, M. Castellano<sup>1</sup>, L. Catani<sup>4</sup>, M. Cestelli-Guidi<sup>1</sup>, V. Chiarella<sup>1</sup>, A. Clozza<sup>1</sup>, A. Cianchi<sup>4</sup>, R. Cimino<sup>1</sup>, F. Ciocci<sup>14</sup>, E. Chiadroni<sup>1</sup>, C. Curceanu<sup>1</sup>, S. Dabagov<sup>1</sup>, G. Dattoli<sup>14</sup>, P. De Felice<sup>5</sup>, G. Delle Monache<sup>1</sup>, D. Di Gioacchino<sup>1</sup>, D. Di Giovenale<sup>1</sup>, E. Di Palma<sup>14</sup>, G. Di Pirro<sup>1</sup>, A. Doria<sup>14</sup>, U. Dosselli<sup>1</sup>, A. Drago<sup>1</sup>, A. Esposito<sup>1</sup>, R. Faccini<sup>2</sup>, M. Ferrario<sup>1</sup>, G. P. Gallerano<sup>14</sup>, A. Gallo<sup>1</sup>, M. Gambaccini<sup>11</sup>, C. Gatti<sup>1</sup>, G. Gatti<sup>1</sup>, A. Ghigo<sup>1</sup>, L. Giannessi<sup>14</sup>, F. Giorgianni<sup>2</sup>, E. Giovenale<sup>14</sup>, G. Guaraldo<sup>1</sup>, R. Gunnella<sup>8</sup>, S. Ivashyn<sup>12</sup>, S. Loreti<sup>5</sup>, S. Lupi<sup>2</sup>, A. Marcelli<sup>1</sup>, C. Mariani<sup>16</sup>, M. Mattioli<sup>2</sup>, G. Mazzitelli<sup>1</sup>, P. Michelato<sup>3</sup>, M. Migliorati<sup>2</sup>, C. Milardi<sup>1</sup>, E. Milotti<sup>13</sup>, S. Morante<sup>4</sup>, D. Moricciani<sup>2</sup>, A. Mostacci<sup>2</sup>, V. Muccifora<sup>1</sup>, P. Musumeci<sup>10</sup>, E. Pace<sup>1</sup>, C. Pagani<sup>3</sup>, V. Palmieri, L. Palumbo<sup>2</sup>, M. Pedio, A. Perrone<sup>9</sup>, A. Petralia<sup>14</sup>, V. Petrillo<sup>3</sup>, P. Pierini<sup>3</sup>, A. Pietropaolo, M. Pillon, R. Pompili<sup>4</sup>, C. Quaresima<sup>15</sup>, L. Quintieri<sup>5</sup>, J. V. Rau, C. Ronsivalle<sup>14</sup>, J. B. Rosenzweig<sup>10</sup>, A. A. Rossi, A. R. Rossi<sup>3</sup>, E. Sabia<sup>14</sup>, L. Serafini<sup>3</sup>, D. Sertore<sup>3</sup>, O. Shekhovtsova<sup>12</sup>, I. Spassovsky<sup>14</sup>, T. Spadaro<sup>1</sup>, B. Spataro<sup>1</sup>, V. Surrenti<sup>14</sup>, A. Tenore<sup>1</sup>, A. Torre<sup>14</sup>, C. Vaccarezza<sup>1</sup>, A. Vacchi<sup>13</sup>, P. Valente<sup>2</sup>, G. Venanzoni<sup>1</sup>, S. Vescovi<sup>1</sup>, F. Villa<sup>1</sup>, N. Zema<sup>15</sup>, M. Zobov<sup>1</sup>.

# IRIDE

Interdisciplinary Research Infrastructure with Dual Electron  
linac&laser

Massimo.Ferrario@lnf.infn.it  
on behalf of

- (1) INFN-LNF
- (2) INFN and Universita' di Roma"La Sapienza"
- (3) INFN and Universita' di Milano
- (4) INFN and Universita' di Roma"Tor Vergata"
- (5) Istituto Nazionale di Metrologia delle Radiazioni Ionizzanti, ENEA C R Casaccia.
- (7) INFN and Universidade Federal da Paraiba, Brazil
- (8) Universita' di Camerino
- (9) INFN and Universita' del Salento
- (10) UCLA, Los Angeles, USA
- (11) INFN and Universita' di Ferrara
- (12) ITP NSC KIPT, Kharkov, Ukraine
- (13) INFN and Universita' di Trieste
- (14) ENEA – Frascati
- (15) CNR
- (16) CNISM and Universita' di Roma"La Sapienza"

# IRIDE

An Interdisciplinary Research Infrastructure based on Dual Electron linac&laser

**Giovedì 14 Marzo – Auditorium Touschek – INFN-LNF**

## 10:15 Welcome coffee

11:00 Welcome Address – U. Dosselli (LNF director)

*11:15 Plenary session 1 – chair: Dr. U. Dosselli (LNF director)*

11:15 IRIDE Overview – M. Ferrario (INFN-LNF)

11:45 Superconducting linac system – P. Pierini (INFN-Mi)

12:15 High energy laser system – L. Serafini (INFN-Mi)

## 13:00 Lunch break

*14:00 Plenary session 2 – chair: Dr.ssa. R. Fantoni (ENEA-Frascati)*

14:00 Electron-positron and electron-electron colliders - D. Babusci (INFN-LNF)

14:20 Electron-gamma collider – G. Venanzoni (INFN-LNF)

14:40 Photon-photon collider - E. Milotti (Uni. Trieste & INFN-Ts)

15:00 Free electron laser sources – G. Dattoli (ENEA-Frascati)

15:20 Free electron laser scientific case – M. Benfatto (INFN-LNF)

15:40 Detectors for free electron lasers – A. Castoldi (Politecnico-Mi)

## 16:00 Coffee break

*16:30 Plenary session 3 – chair: Prof.ssa C. Petrillo (Università di Perugia)*

16:30 Thz source – E. Chiadroni (INFN-LNF)

16:45 Thz source scientific case – S. Lupi (Uni. Roma – La Sapienza)

17:00 Neutron source – P. Valente (INFN-RM1)

17:15 Neutron source scientific case – T. Pietropaolo (ENEA-Frascati)

17:30 Nuclear photonics - G. Colo' (INFN-Mi)

18:00 Advanced accelerator concepts – A. R. Rossi (INFN-Mi)

## 18:30 END of day 1

**Venerdì 15 Marzo – Auditorium Touschek - LNF**

*9:15 Plenary session 1 - Auditorium Touschek*

9:15 Working group tasks and organization

## 10:15 Coffee break

*10:45 Parallel sessions*

Aula Seminari Div Acc.:

**WG1 - Electron Machine (SC linac and RF) including:**

- Physics of and with FELs, Detectors,
- THz Source,
- Neutron Source

Aula Conversi:

**WG2: Photon Machine (Lasers and Optics) including:**

- Physics of and with Compton Sources, Detectors
- $\gamma$ - $\gamma$  and e- $\gamma$  colliders

Auditorium Touschek:

**WG3: Electron-electron and electron-positron colliders**

## 13:00 Lunch break

*14:00 Plenary session 2 – WG Summary and discussion - Auditorium Touschek*

14:00 WG1 Summary A. Gallo (INFN-LNF)

14:15 WG2 Summary C. Vaccarezza (INFN-LNF)

14:30 WG3 Summary C. Gatti (INFN-LNF)

14:45 Discussion

## 16:00 END of day 2

Università del Salento

Università del Salento

Angeles, USA

Università di Ferrara

Kharkov, Ukraine

Università di Trieste

IEA

NR

Università di Roma "La Sapienza"

(17) Politecnico di Milano and INFN-Mi

, Universities)  
(id=6006)

<https://agenda.infn.it/conferenceDisplay.py?ovw=True&confId=6006>



**I R I D E** is a large infrastructure for fundamental and applied physics research. Conceived as an **innovative** and **evolutionary** tool for **multi-disciplinary investigations** in a wide field of scientific, technological and industrial applications, it will be a high intensity “**particle beams factory**”.

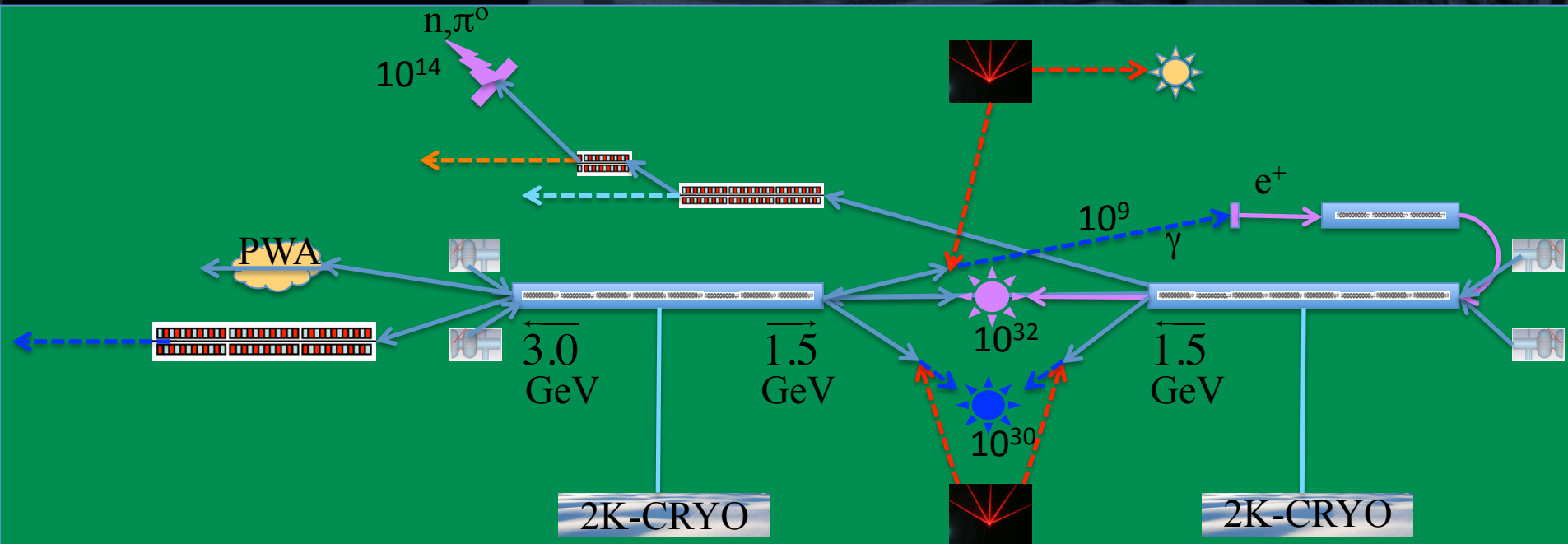

Based on a combination of a **high duty cycle radio-frequency superconducting electron linac** (SC RF LINAC) and of **high energy lasers** it will be able to produce a high flux of **electrons, photons (from infrared to  $\gamma$ -rays)**, neutrons, protons and eventually **positrons**, that will be available for a wide national and international scientific community interested to take profit of the most advanced particle and radiation sources.

The main feature of a **SC linac** relevant for **IRIDE** is the possibility to operate the machine in **continuous (CW)** or **quasi-continuous wave (qCW)** mode with high average beam power (**>1 MW**) and high average current (**>300  $\mu\text{A}$** ).

**Pulsed operation (DC 1%), 1GeV model linac**

30  $\mu\text{A}$  average, 30 kW beam, 10 Hz pulses  
3 mA pulse current, 5 MHz intrapulse repetition rate

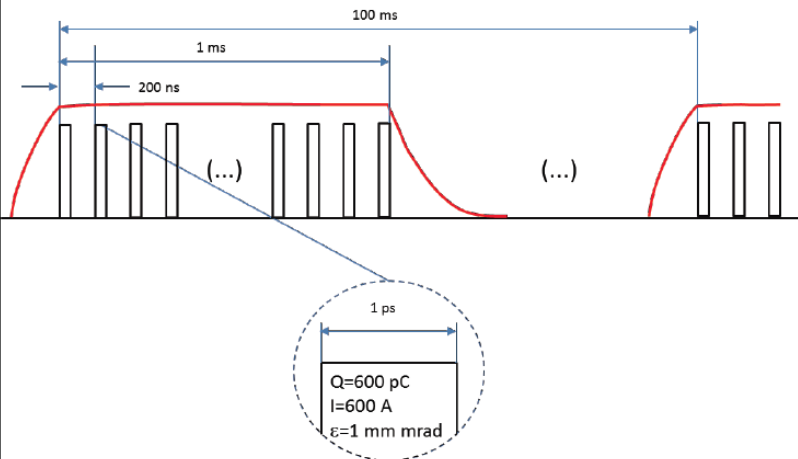

**CW operation, 1 GeV model linac**

0.4 mA, 0.4 MW beam at 2 MHz repetition rate

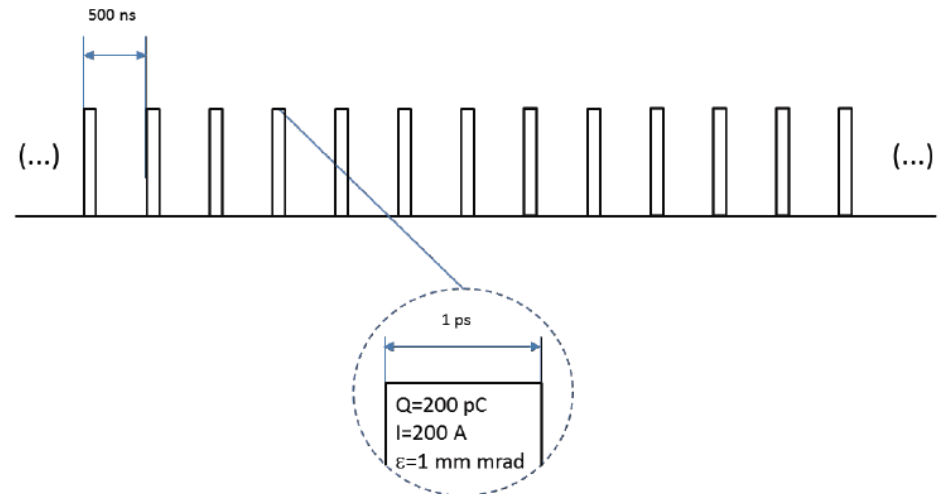

The **CW** or **qCW** choice, combined with a proper bunch distribution scheme, offers the **most versatile solution to provide bunches to a number of different experiments**, as could be envisaged in a multi-purpose facility.

# IRIDE LINAC

## possible pulsed Configurations (single linac)

$$Q_{ext}^{opt} \approx \frac{V_{acc}}{(R/Q)I_b}$$

$$\frac{P_{ref}}{P_{fwd}} = |\rho|^2 \approx \frac{(Q_{ext}^{opt} - Q_{ext})^2}{(Q_{ext}^{opt} + Q_{ext})^2}$$

$$V_{asympt} \approx 2\sqrt{(R/Q)Q_{ext}P_{RF}}$$

	Pulse 1	Pulse 2	Pulse 3
E [GeV]	1	1,5	2
I (within pulse) [mA]	4	3	2
I (average) [mA]	0,47	0,28	0,12
Pulse rep. rate [Hz]	100	100	100
RF pulse duration [ms]	1,5	1,5	1,5
RF Duty cycle [%]	15	15	15
Beam pulse duration [ms]	1,16	0,93	0,60
Beam Duty cycle [%]	11,6	9,3	6,0
f <sub>RF</sub> [MHz]	1300	1300	1300
E <sub>acc</sub> [MV/m]	7,53	11,29	15,05
Cavity length L [m]	1,038	1,038	1,038
R/Q [Ohm]	1036	1036	1036
Q <sub>0</sub>	1,50E+10	1,20E+10	1,00E+10
Q <sub>ext_opt</sub>	1,89E+06	3,77E+06	7,54E+06
Q <sub>ext</sub>	3,50E+06	3,50E+06	3,50E+06
Reflected RF power [%]	9,0	0,14	13,5
Cavity BW [Hz]	185,71	185,71	185,71
Cavity rise time [ms]	0,86	0,86	0,86
Rise-time to target V <sub>acc</sub> [ms]	0,34	0,57	0,90
# of cavies	128	128	128
# of modules	16	16	16
P <sub>beam/cavity</sub> (pulse) [kW]	31,25	35,16	31,25
P <sub>beam/cavity</sub> (ave) [kW]	4,69	5,27	4,69
P <sub>RF/cavity</sub> (pulse) [kW]	34,06	35,20	35,44
P <sub>RF/cavity</sub> (ave) [kW]	5,11	5,28	5,32
Available P <sub>RF/cavity</sub> (pulse) [kW]	40,00	40,00	40,00
unloaded asymptotic voltage [MV]	24,09	24,09	24,09
P <sub>cryo_RF</sub> (@ 2 K) [W]	75,41	212,09	452,46
P <sub>cryo_static</sub> (@ 2 K) [W]	56,00	56,00	56,00
P <sub>cryo_total</sub> (@ 2 K) [W]	131,41	268,09	508,46
Total P <sub>beam</sub> (peak) [kW]	4000	4500	4000
Total P <sub>beam</sub> (ave) [kW]	465,60	417,95	241,39
Linac length [m]	192	192	192

# IRIDE LINAC

## possible RF sources

- x 3 pulse duration (from 0.5 to 1.5 ms);
- 1/3 peak power (from 5.1 to 1.7 MW);
- same rep rate (100 Hz) and ave Power (250 kW)

**Reasonable but to be verified with manufacturer!**



RF performance	TH 2104 C	TH 2104 D	TH 2104 U		
Frequency	1.3	1.3	1.3	GHz	
RF output power					
• peak	5.1	5.1	10.2	MW	
• average	100	250	250	kW	
Peak RF drive power	200	200	320	W	max.
RF pulse duration	2 000	500	250	µs	max.
- 1dB bandwidth	8	8	8	MHz	min.
Saturated gain	47	47	50	dB	typ.
Efficiency	46	45	45	%	typ.

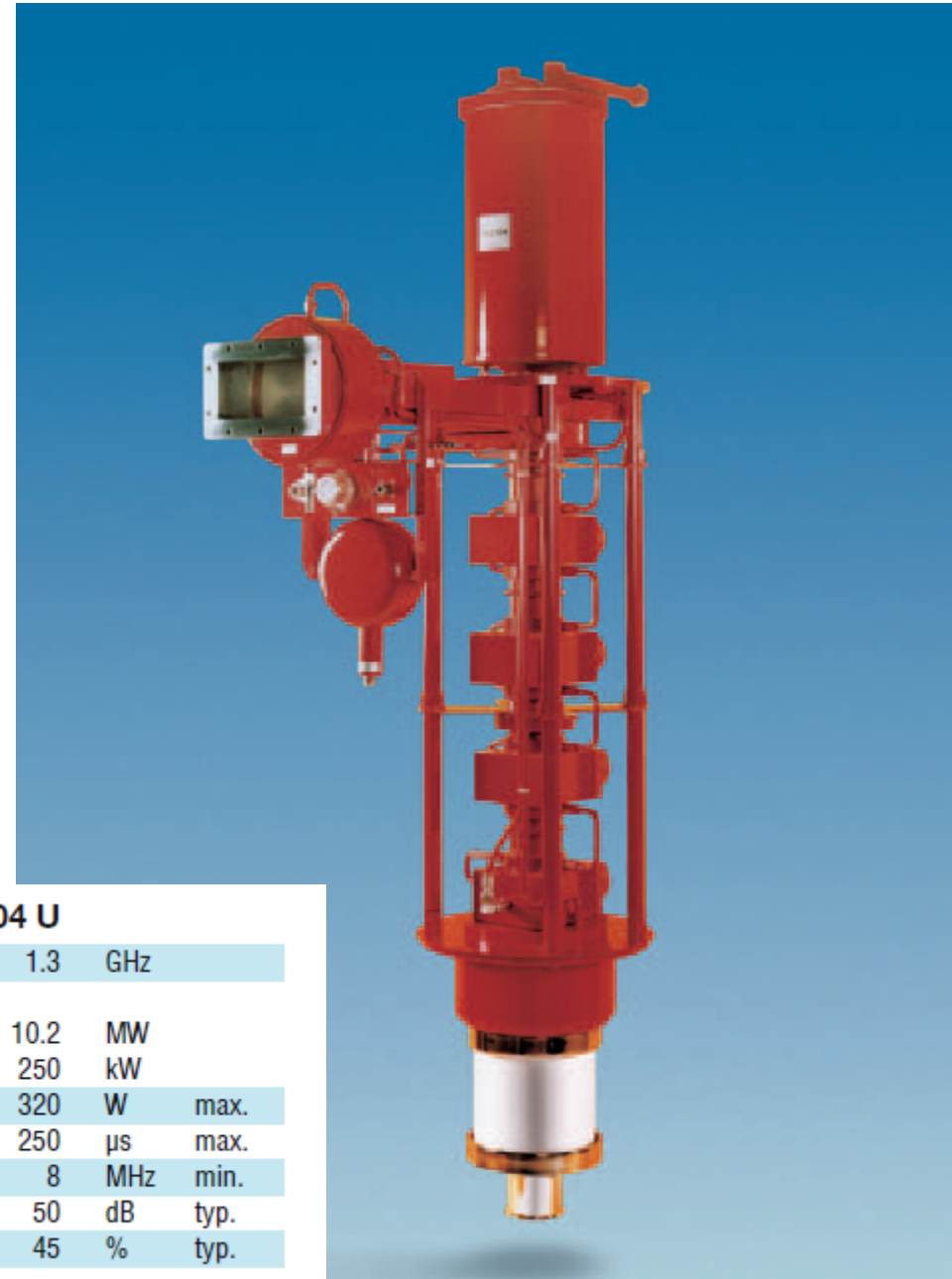



INFN is in a **leading position in the SC RF technology**, with knowledge and strong capabilities in the design, engineering and industrial realization of all the main component of a superconducting radiofrequency accelerator.

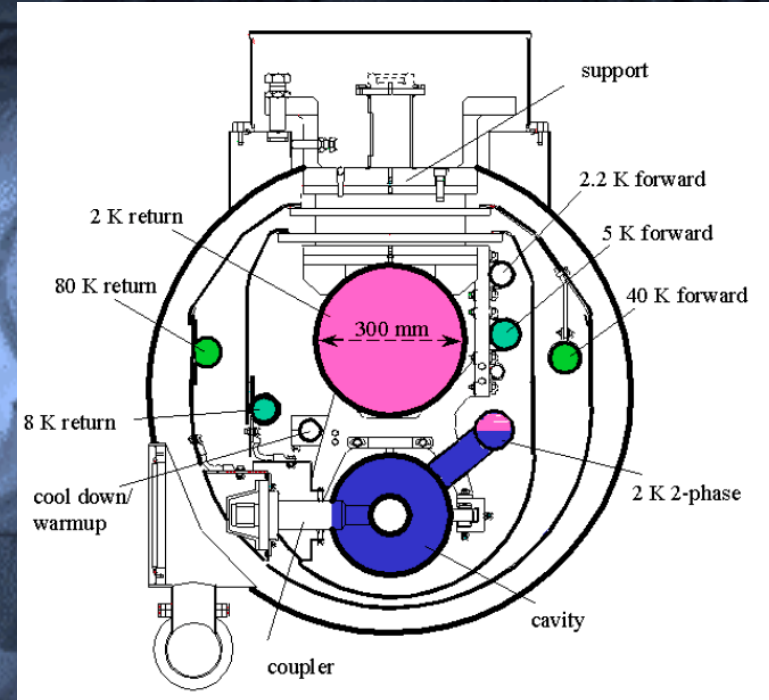
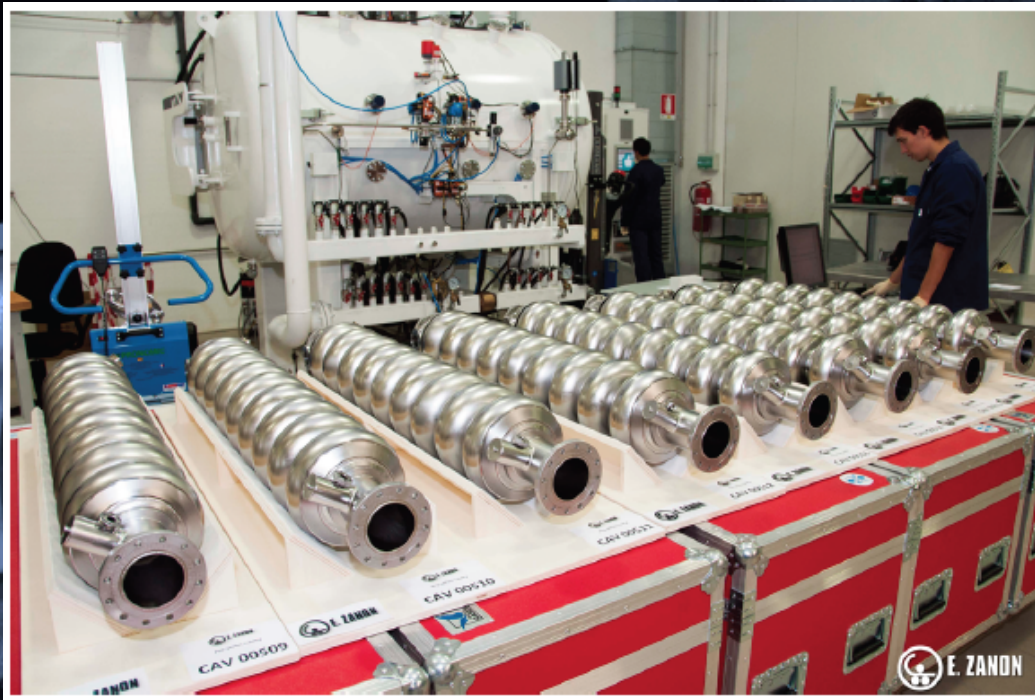

INFN strongly participated to TESLA since the early design stages through the final engineering and shares the know-how and **has the recognized intellectual property of several main components one of which is the cryo-module concept and its evolution.**



# XFEL Italian In-Kind contribution

- **INFN** contributed to linac design
- Italian industry, with INFN supervision provides
  - **400/800** of the 1.3 GHz cavities
    - Fabricated, processed, ready for RF tests
  - **45/100** of the cryomodules
- INFN provides also
  - High QE photocathode preparation/transport system
  - Cavities/Cryomodule for the 3.9 GHz linearizer
- i.e. main components for a **9 GeV SC linac...**

# Electron Guns

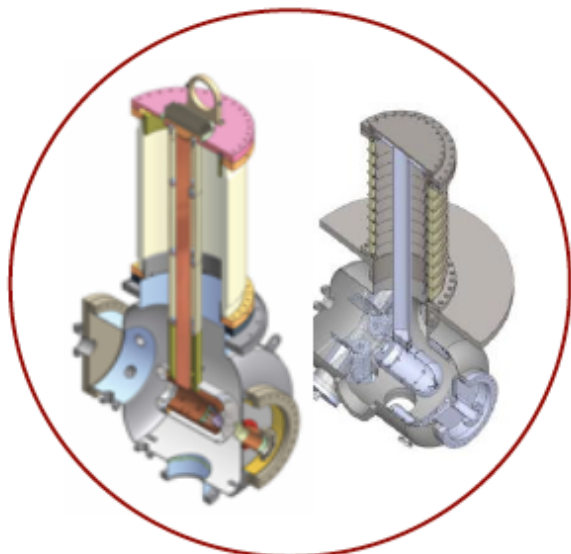

DC guns

- CW operation
- High field
- Low pressure
- Low Dark current



Hybrid Schemes

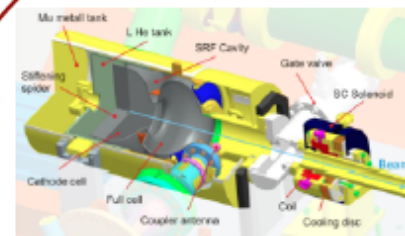

SC RF guns

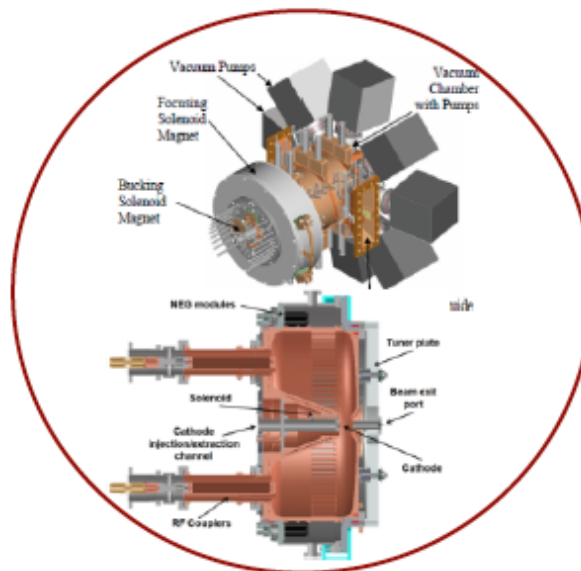

Low freq. (<~ 700 MHz) NC CW RF guns

# The LBNL VHF Gun

The Berkeley **normal-conducting** scheme satisfies all the LBNL FEL requirements simultaneously.

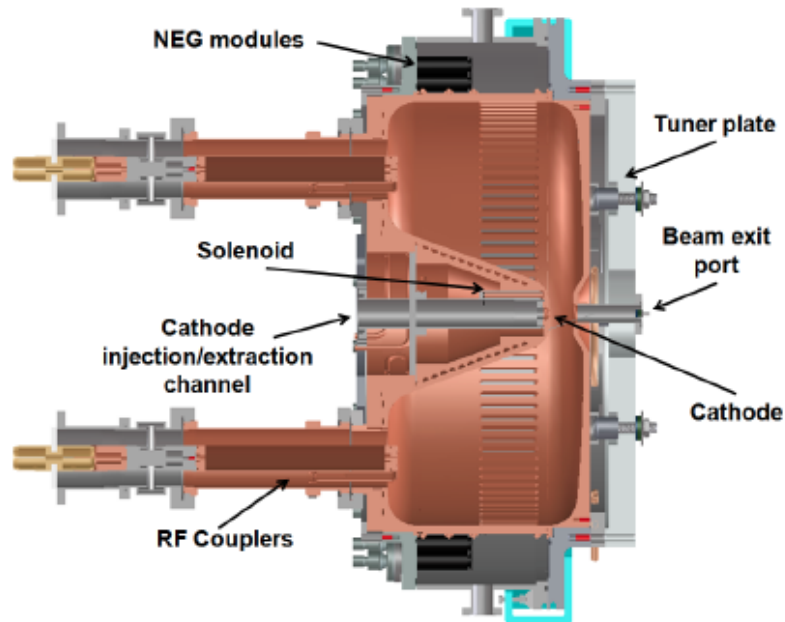

Frequency	186 MHz
Operation mode	CW
Gap voltage	750 kV
Field at the cathode	19.47 MV/m
$Q_0$ (ideal copper)	30887
Shunt impedance	6.5 M $\Omega$
RF Power	100 kW
Stored energy	2.3 J
Peak surface field	24.1 MV/m
Peak wall power density	25.0 W/cm <sup>2</sup>
Accelerating gap	4 cm
Diameter/Length	69.4/35.0 cm
Operating pressure	$\sim 10^{-11}$ Torr

J. Staples, F. Sannibale, S. Virostek, CBP Tech Note 366, Oct. 2006

K. Baptiste, et al, NIM A 599, 9 (2009)

- At the **VHF frequency**, the cavity structure is large enough to withstand the heat load and **operate in CW mode** at the required gradients.
- Also, the **long  $\lambda_{RF}$**  allows for large apertures and thus for **high vacuum conductance**
- Based on **mature and reliable normal-conducting RF and mechanical technologies**.

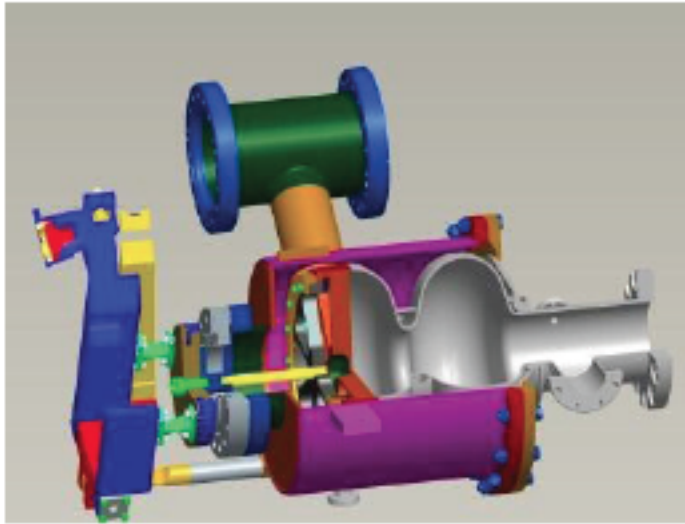

# BERLINpro SCRF

Gun0.1 and Gun0.2 JLab RF Test Results

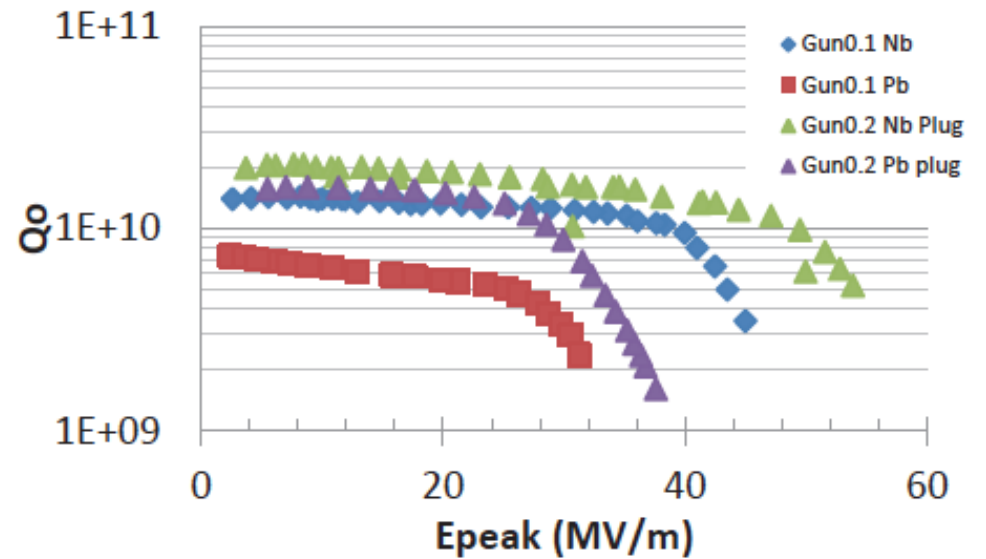

The **laser system complex** is deputed to deliver optical photon beams able to fulfill the several requirements of the IRIDE facility:

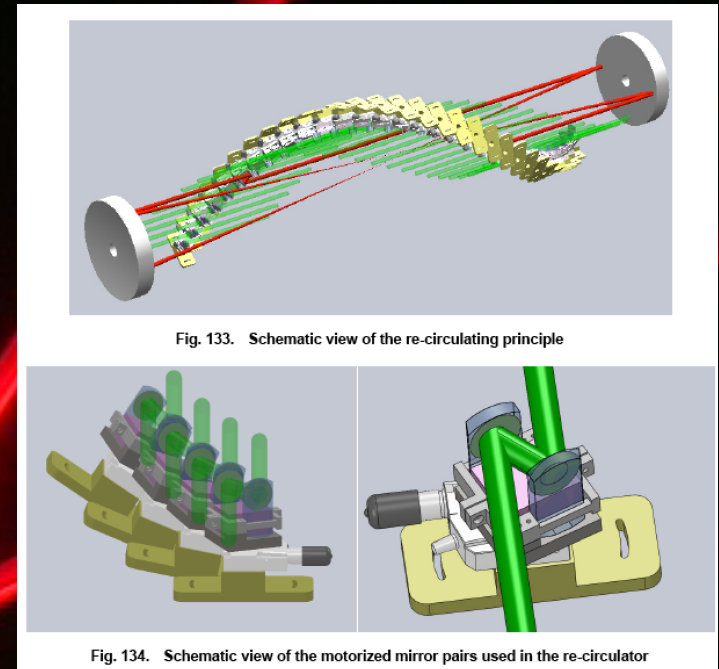
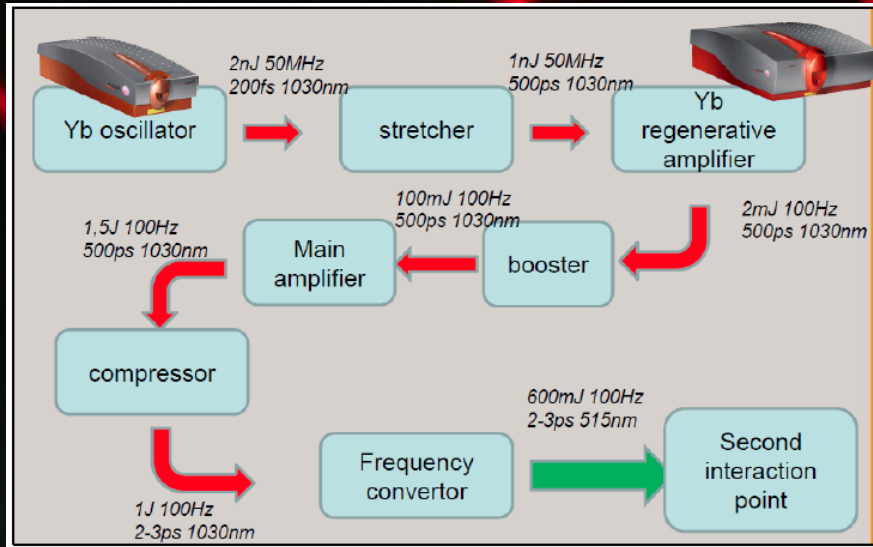

- drivers of photo-cathodes for electron beam generation
- colliding laser pulses to drive the back-scattering Compton  
(**Yb:YAG**, 100 W, **1 J**, **0.1% bw**)
- drivers for high advanced acceleration experiments  
(**Ti:Sa**, **1 PW**,  $10^{22}$  W/cm<sup>2</sup>)

# Free electron Lasers

The **IRIDE** project will provide a **new concept of FEL facility** by merging the two technologies of **FEL oscillators** and **fourth generation radiation sources** by developing a facility providing radiation from **IR to EUV to the nm region down to Å level** using a mechanism of emission already successfully tested at SPARC.

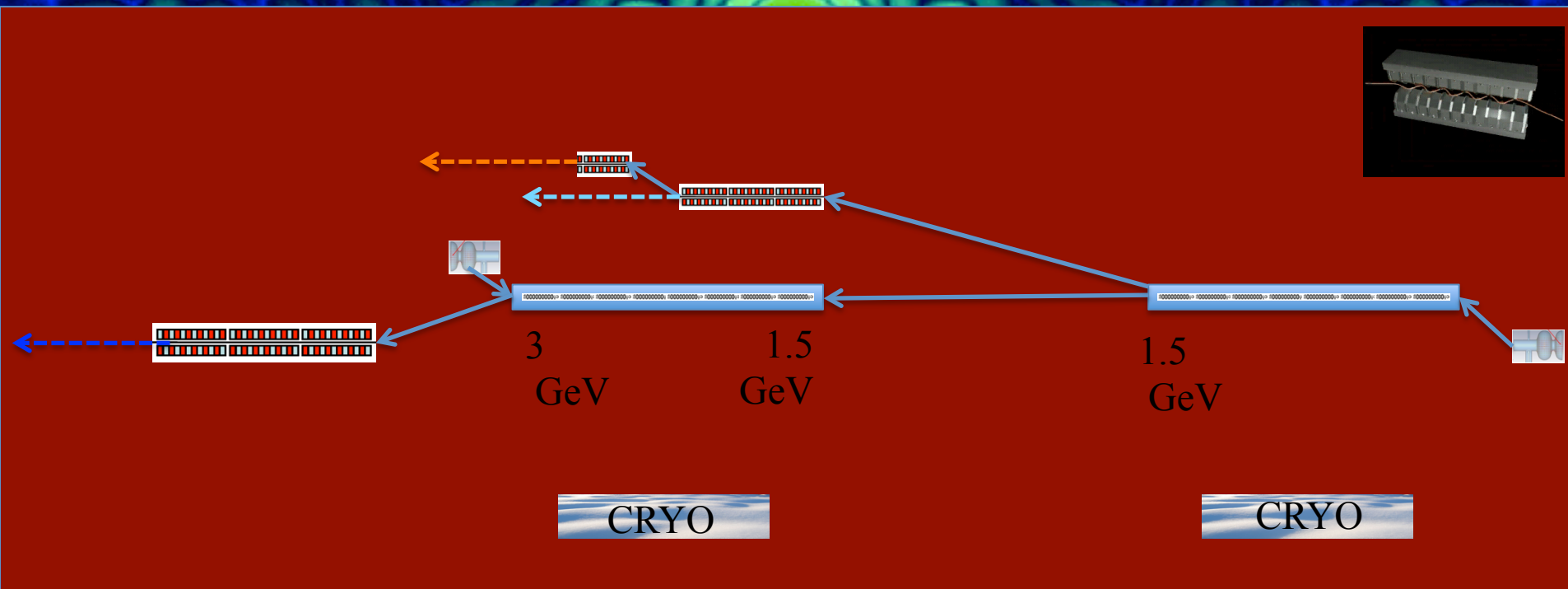

# Integrated «architecture»

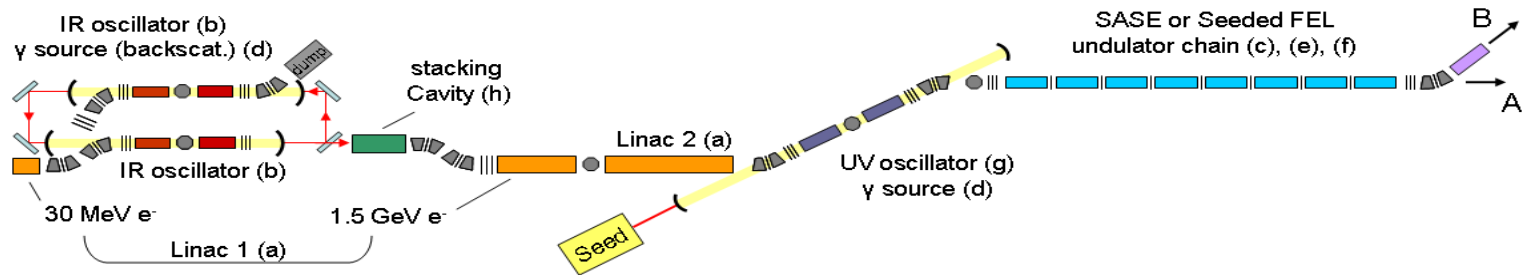

***S-C-LINAC structures with 3-4 GeV maximum energy***

***Between the two Linacs a double FEL oscillator, with a manifold role, is inserted***

***The undulator chain can be powered by the beam operating at full energy (3-4 GeV) or less***

***A second FEL oscillator is added for the operation in the UV region and for intra-cavity backscattering for the realization of a gamma source to be exploited for Nuclear Physics studies and the production of polarized electrons***

***The third FEL section may operate in SASE or SEDEED mode***

***The seeding will be achieved by exploiting a conventional seeding procedure or by using the self-seeding scheme based on a kind of oscillator-amplifier device, according to the scheme first developed in Barbini et al. "In prospects for 1 Angstrom FEL" Sag Harbor 1990***



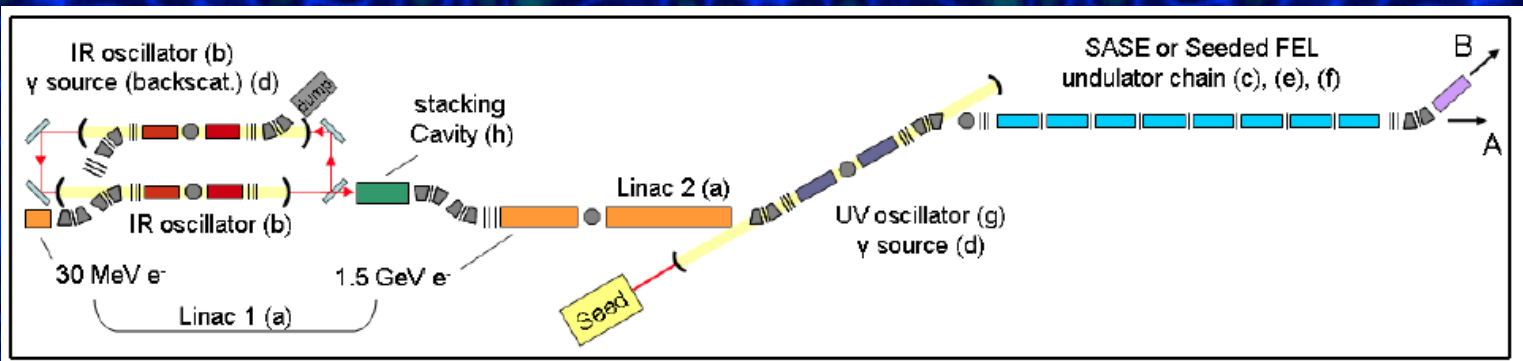

$\lambda(\text{nm/KeV})$	1/1.24	0.3/3.72	0.2/6.2
$\Phi$ peak (n/s/- 0.1%BW)	$4.6 \cdot 10^{25}$	$4.1 \cdot 10^{23}$	$3.4 \cdot 10^{22}$
$B$ (n/s(mm.mrad) <sup>2</sup> - 0.1%BW)	$6.4 \cdot 10^{31}$	$5.7 \cdot 10^{29}$	$4.7 \cdot 10^{28}$
$\tau$ (fs)	220	<200	<180
$\Phi$ (n/s) (medio)	$3.95 \cdot 10^{22}$	$3.51 \cdot 10^{20}$	$2.89 \cdot 10^{19}$
photon/bunch	$1.01 \cdot 10^{13}$	$9.02 \cdot 10^{10}$	$7.48 \cdot 10^9$

$\lambda(\text{nm/KeV})$	4/0.413	1.33/1.23	0.8/2.07
$\Phi$ peak (n/s/- 0.1%BW)	$2.7 \cdot 10^{26}$	$2.5 \cdot 10^{24}$	$1.9 \cdot 10^{23}$
$B$ (n/s(mm.mrad) <sup>2</sup> - 0.1%BW)	$1.56 \cdot 10^{30}$	$1.4 \cdot 10^{28}$	$1.1 \cdot 10^{27}$
$\tau$ (fs)	95	80	<100
$\Phi$ (n/s) (medio)	$1.03 \cdot 10^{23}$	$9.32 \cdot 10^{20}$	$7.33 \cdot 10^{19}$
photon/bunch	$5.94 \cdot 10^{13}$	$5.5 \cdot 10^{11}$	$4,18 \cdot 10^{10}$

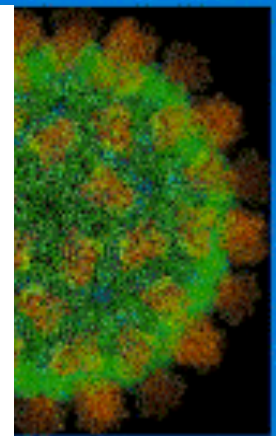

# From the SPARX bio-scientific case

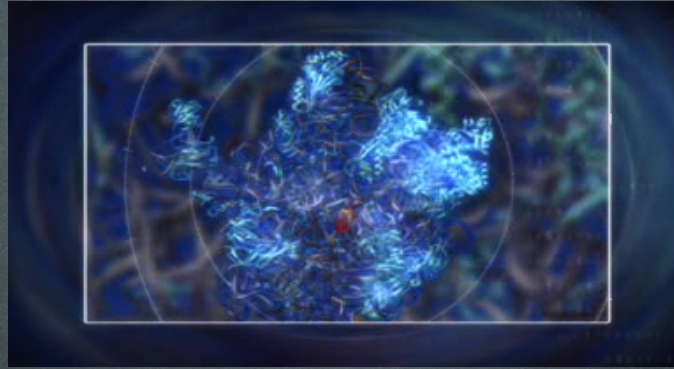

- Time-Resolved diffraction from protein nanocrystals with spontaneous radiation: sub-picosecond pumps & probe structural and spectrometric investigations
- Structural characterization of biological systems, muscle contraction
- Small angle X-ray scattering of biological molecules
- Low density Atomic and Molecular processes with two photons spectroscopy
- X-ray microscopy with nanometer resolution
- Femtosecond Raman spectroscopy
- Single molecule imaging with hard X-rays

# THz radiation source

The interest for having high-power, sub-ps pulsed radiation covering the spectral range from THz to MIR is rapidly growing, both as it is a powerful tool for investigating the behavior of matter at low energy, and as it allows for a number of possible applications spanning from medical science to security.

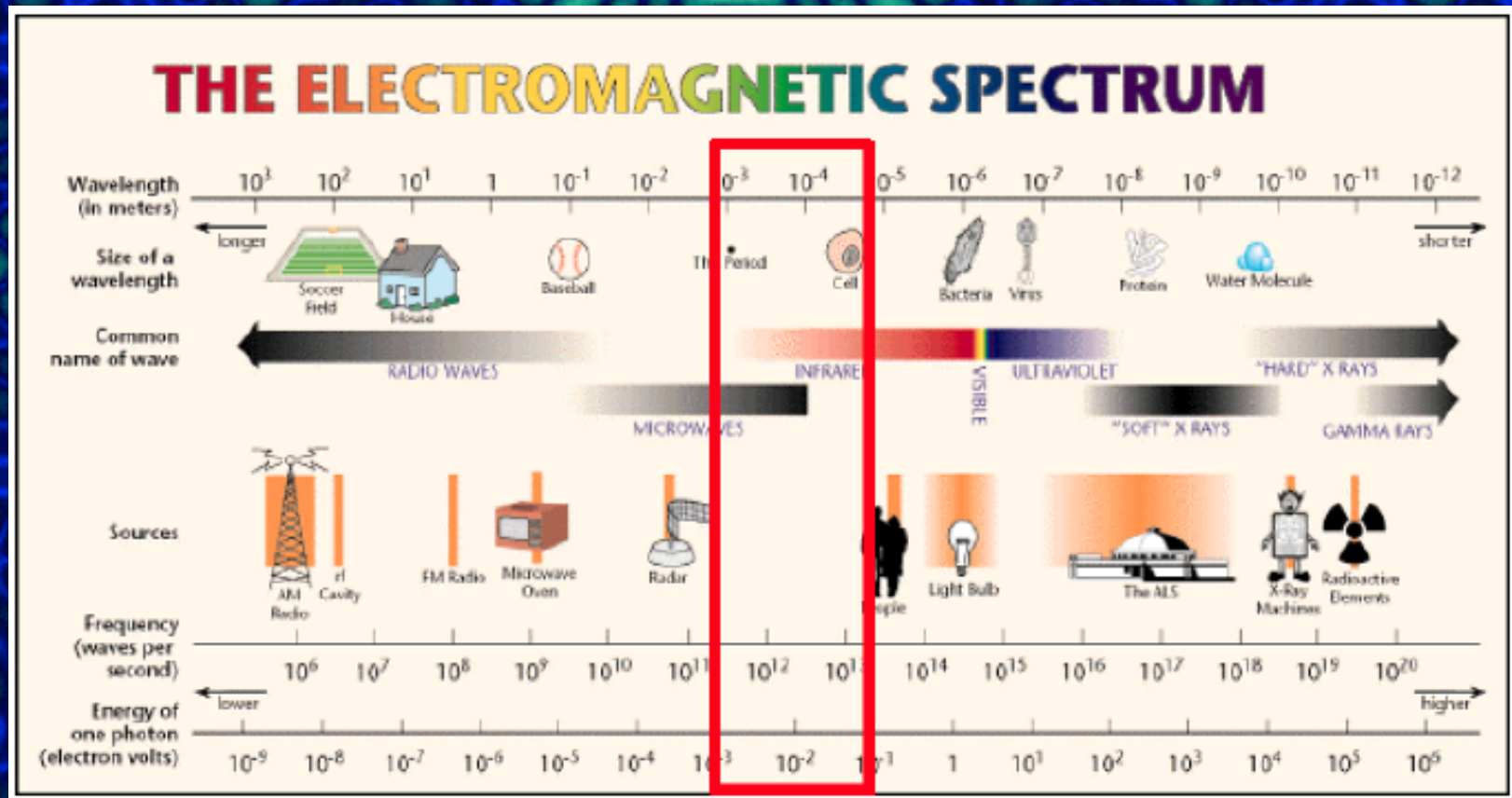

# THz radiation source

## Condensed Matter Physics

### Superconductivity

- Energy gap
- Symmetry of the order parameter
- Direct determination of the superfluid density
- Dynamics of Cooper pairs

### Low-dimensional materials

- Dimensionality crossover
- Non-Fermi liquid normal states
- Broken symmetry ground states

### Coherent Phase Transitions

- Polarons
- Structural Phase Transitions

### Magnetic sub-ps Dynamics

## Physical and Analytical Chemistry

### Polar liquids

- Hydrogen bond
- Van der Waals interactions
- Acoustic-Optic phonon mixing in water

### Solutions

- Static and dynamic interactions between solvated ions and solvent

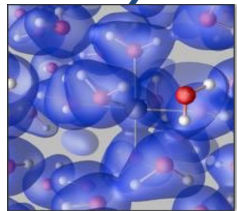
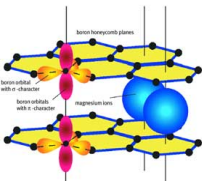

## Life Sciences



### Macromolecules conformation

- Secondary and tertiary structure
- Coherent dynamic development

### Imaging

- 3D tomography of dry tissues
- Near-field sub-wavelength spatial resolution

## New Technologies

### THz technologies

- Array THz detectors
- Metamaterials

### Medical diagnostic

- Skin cancer detection

### Industrial production

- Material inspection
- Production line monitoring

### Defense industry/Homeland security

- Detection of explosives and biohazards

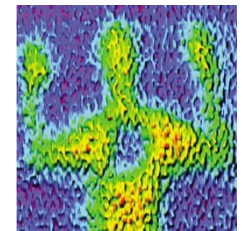

# THz radiation source

Electron beam parameters	
Electron energy (GeV)	1.5 – 0.5
Charge/bunch (pC/bunch)	250
RMS bunch length ( $\mu\text{m}$ )	60
Normalized emittance (mm mrad)	1
Undulator	
Period (cm)	40
Number of periods	10
Magnetic field (T)	0.1 -1
Coherent Undulator Radiation parameters	
Wavelength ( $\mu\text{m}$ )	20 – 200
Peak power (MW)	100
Micropulse energy (mJ)	10
Micropulse duration (fs)	200
Coherent Diffraction Radiation parameters	
Wavelength ( $\mu\text{m}$ )	> 60
Peak power (MW)	100
Micropulse energy ( $\mu\text{J}$ )	> 10
Micropulse duration (fs)	200

# Neutron Source

A Neutron Source can be realized by **photo-production** sending high energy electrons on a suitable high Z target. This kind of source allows to obtain **neutrons with an energy spectrum** that spans over more than 9 decades of energy **from few meV up to hundred of MeV**, even if most of them have energy around the nuclear equilibrium temperature of the target material (for W, it is around 1 MeV)

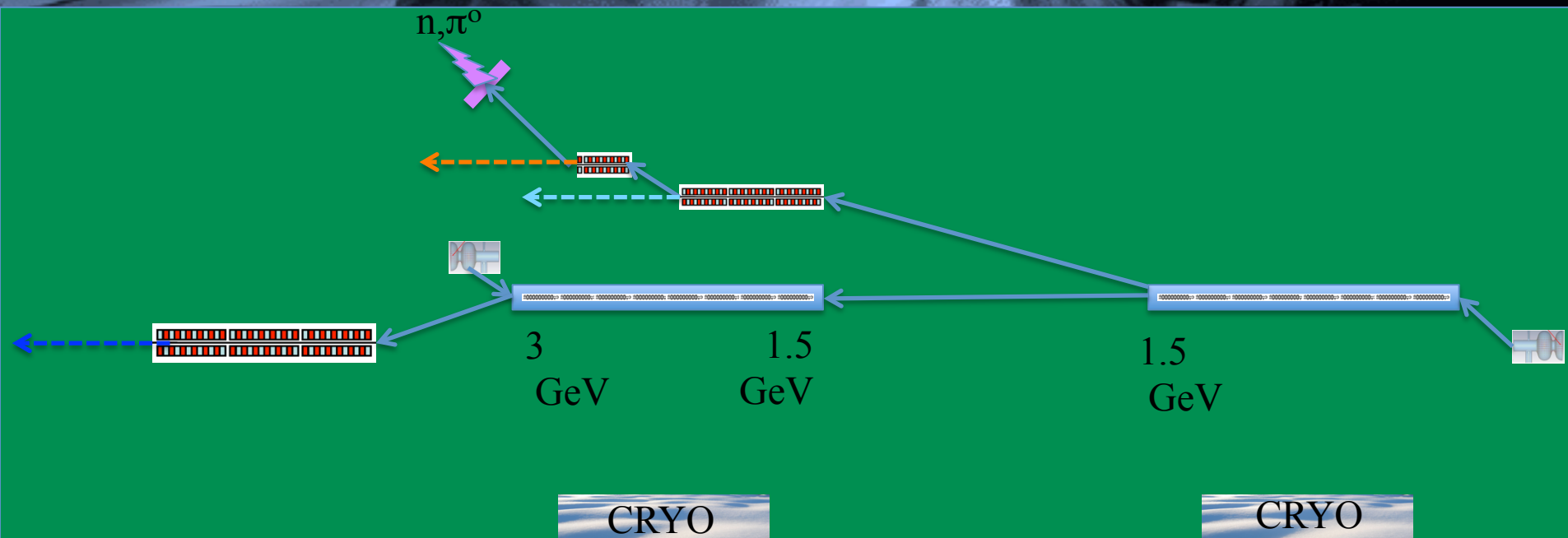

# Neutron Source

This source may be suitable for multiple applications, ranging from material analysis for industrial and cultural heritages purposes to chip irradiation and metrology. These applications envisage the development of properly designed beam lines with neutron moderation and possibly cold/thermal neutron transport systems. The proposed new facility will represent a great opportunity for research and development of neutron instrumentation (e.g. detectors) as well as training of young scientist in the use and development of neutron techniques.

Deposited Power [kW]	Primary Electron Energy [GeV]	Expected Average Neutron rate [n/s]
30	1	1.3 E+14
250	1	1.0 E+15
400	1	1.7 E+15
30	3	4.3 E+13
250	3	3.3 E+14
400	3	5.6 E+14

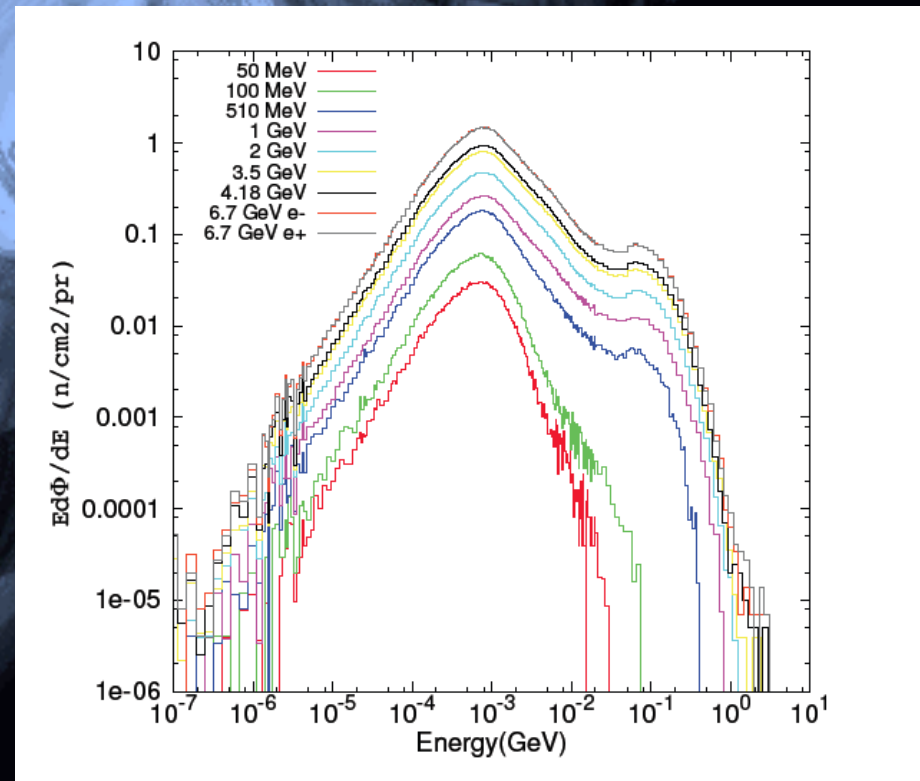

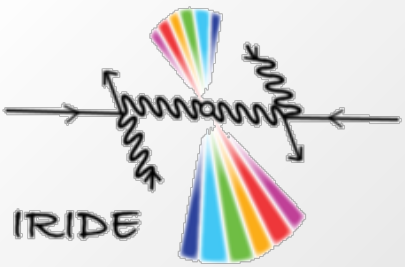

# Comparison with other sources

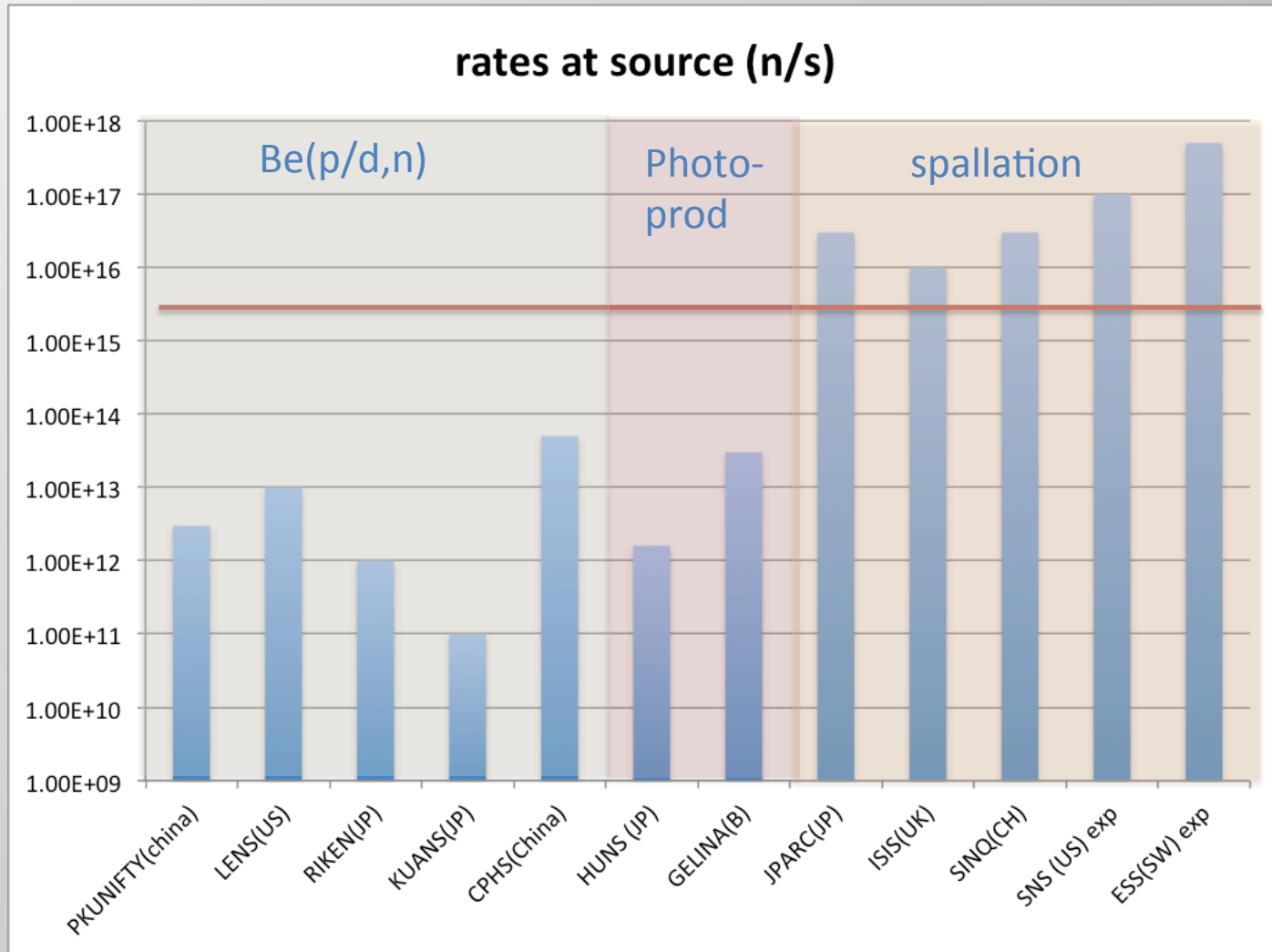



# Neutron Source

**Neutron Resonance Capture Analysis (NRCA):** Each resonance is the fingerprint of a nuclear specie (isotopical recognition) thus allowing for the elemental material analysis (qualitative and quantitative) especially on metallic samples (e.g. cultural heritages).

**Bragg Edge Transmission (BET):** By means of this technique, stresses and strain in bulky samples can be analysed. This analysis is very important for both industrial as well as cultural heritages applications.

**Chip irradiation :** In order to test the robustness of electronic devices to neutron field in a few minutes, neutron beams produced at facilities are desirable as they may provide an almost atmospheric-like neutron spectrum but several orders of magnitude more intense.

**Radiography and Tomography (NR, NT):** By means of radiography it is possible to obtain an image of an object that evidences the internal structure, by rotating the sample with respect to the incident beam and collecting images for each angular position a 3D image of the object is obtained (tomography).

**Neutron metrology:** In this context, the Italian National Institute of Ionization Radiation Metrology (INMRI) is interested in having in Italy (and especially in the Roma area) a high energy neutron source in order to develop primary standards for neutron emission rate and energy spectrum calibration.

The special feature of Neutrograph is its intensity together with a moderate collimation.

These properties allow the investigation of dynamic processes with an excellent time resolution and the transmittance through strongly absorbing and bulky materials.

A totally new spectrum of scientific and engineering applications could be developed.

Among the experiments are investigations of heat exchangers and combustion engines, parts from aircrafts, fossils and historical heritage.

Institut Laue-Langevin (ILL) in Grenoble



# Advanced $\gamma$ -ray Compton Source

The state of the art in producing high brilliance/spectral density mono-chromatic  $\gamma$ -ray beams will be soon enhanced, stepping up from the present performances ( $\gamma$ -ray beams with bandwidth nearly 3% and spectral density of about 100 *photons/s.eV*) up to what is considered the threshold for Nuclear Photonics, *i.e.* a bandwidth of the  $\gamma$ -ray beam lower than 0.3% and a spectral density larger than  $10^4$  *photons/s.eV*.

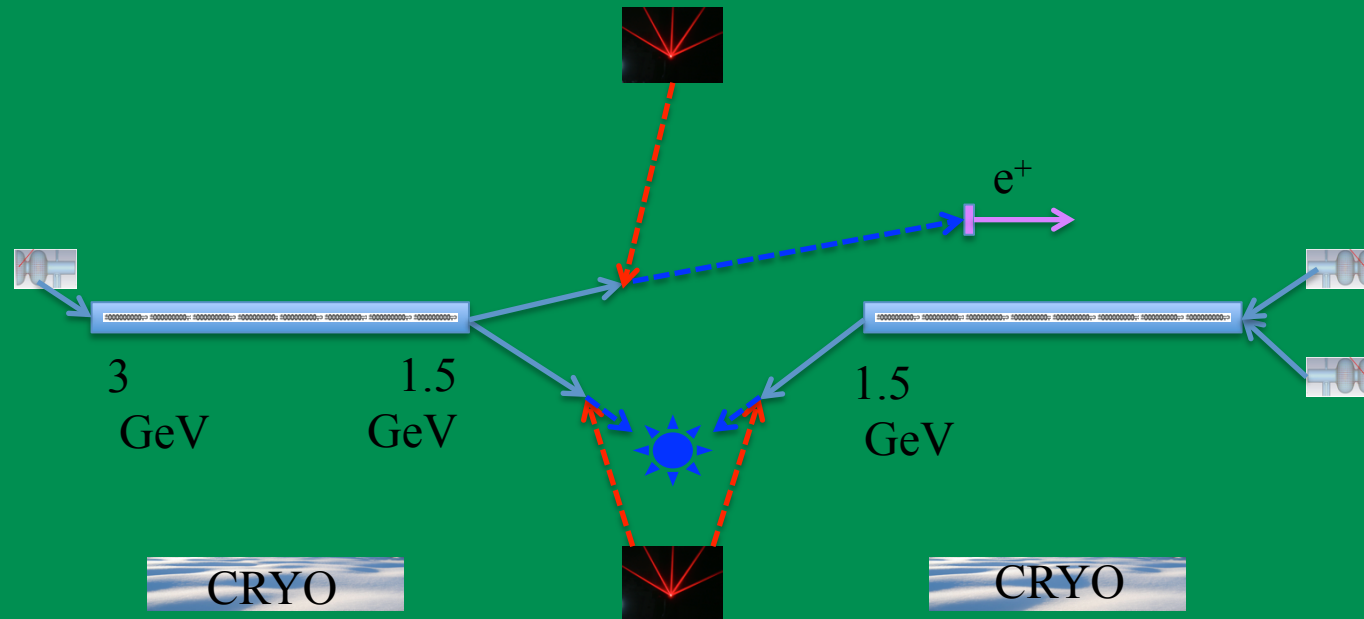

- colliding laser pulses to drive the back-scattering Compton (**Yb:YAG**, 100 W, 1 J, 0.1% bw)

# Advanced $\gamma$ -ray Compton Source

Parameters for ELI-NP case Recirculator	Units	Thomson Compton Source
Beam energy	[GeV]	1
Charge	[nC]	0.5
Bunch length rms	[ $\mu\text{m}$ ]	300
Peak current	[A]	200
effective Rep. rate	[Hz]	60x100
Average current	[ $\mu\text{A}$ ]	3
rms spot size at collision	[ $\mu\text{m}$ ]	5
coll. Laser eff. Power	[kW]	0.1
coll. Laser pulse energy	[J]	1
rms norm. emittance	[ $\mu\text{m}$ ]	0.5
beta-funct. at coll. (1 GeV)	[ $\mu\text{m}$ ]	100
# $\gamma$ /shot		$6.0 \cdot 10^8$
# $\gamma$ /s	[ $\text{s}^{-1}$ ]	$3.6 \cdot 10^{12}$

Parameters for SC-qCW case Fabry-Perot	Units	Thomson Compton Source
Beam energy	[GeV]	1
Charge	[nC]	0.5
Bunch length rms	[ $\mu\text{m}$ ]	300
Peak current	[A]	200
Effective Rep. rate	[Hz]	9400x100
Average current	[ $\mu\text{A}$ ]	470
rms spot size at collision	[ $\mu\text{m}$ ]	5
coll. Laser eff. Power	[kW]	1000
coll. Laser pulse energy	[J]	0.01
rms norm. emittance	[ $\mu\text{m}$ ]	0.5
beta-funct. at coll. (1 GeV)	[ $\mu\text{m}$ ]	100
# $\gamma$ /shot		$6.0 \cdot 10^6$
# $\gamma$ /s	[ $\text{s}^{-1}$ ]	$5.6 \cdot 10^{12}$

# Advanced $\gamma$ -ray Compton Source

- studies of the nucleus structure at the Pigmy and **Giant Dipole Resonance** with unprecedented resolution in reconstructing the nuclear states: this is crucial also to understand some unknown processes in the stellar nucleo-synthesis
- studies of two **level barionic states in the high energy resonance of the nuclei**, above  $20 \text{ MeV}$  and up to  $60 \text{ MeV}$ , crucial to reconstruct the equation of state of the nuclear matter
- **detection and imaging of fissile and strategic material** with isotopic reconstruction of the components with large impact on the national security scenario
- **remote sensing and diagnosis of nuclear wastes in containers**, with reconstruction of the isotope and nuclear composition of the waste material, with large impact on the atomic energy scenario
- **medical imaging and therapy**

# $\gamma$ -e Linear Collider

The precise measurement of the  $\pi^0$  width through the process  $e\gamma \rightarrow \pi^0 e$  (*Primakoff effect*), and the search for **light dark bosons in the energy region of few to hundreds MeV**. These measurements, which provide important tests of the Standard Model, **are not possible at present electron-photon colliders due to the low photon intensities of the machines**.

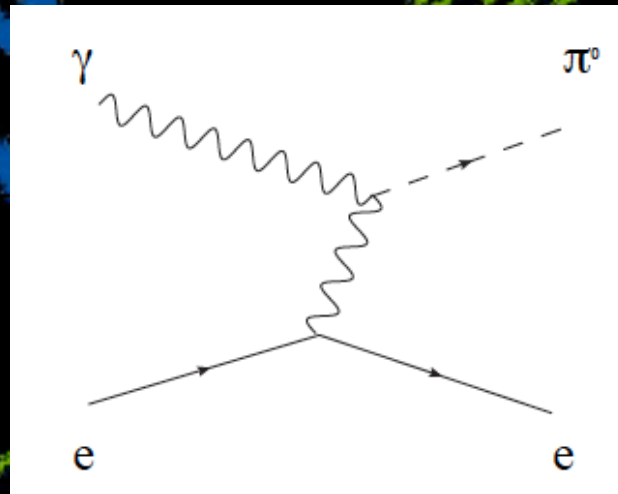

**$\pi^0$  width measurement:** the axial anomaly of Adler, Bell and Jackiw (non-conservation of the axial vector current) is responsible for the decay of the neutral pion into two photons. It bridges in QCD the strong dynamics of infrared physics at low energies (pions) with the perturbative description in terms of quarks and gluons at high energies. The anomaly allows to gain insights into the strong interaction dynamics of QCD and has received great attention from theorists over many years.

# Motivation

$$2\sqrt{T_e \cdot h\nu_\gamma}$$

CM energy (MeV)

2000

1500

1000

500

500

1000

1500

2000

2500

electron energy (MeV)

213 nm

266 nm

355 nm

532 nm

1064 nm

$\eta'$

$\eta$

$\pi_0$

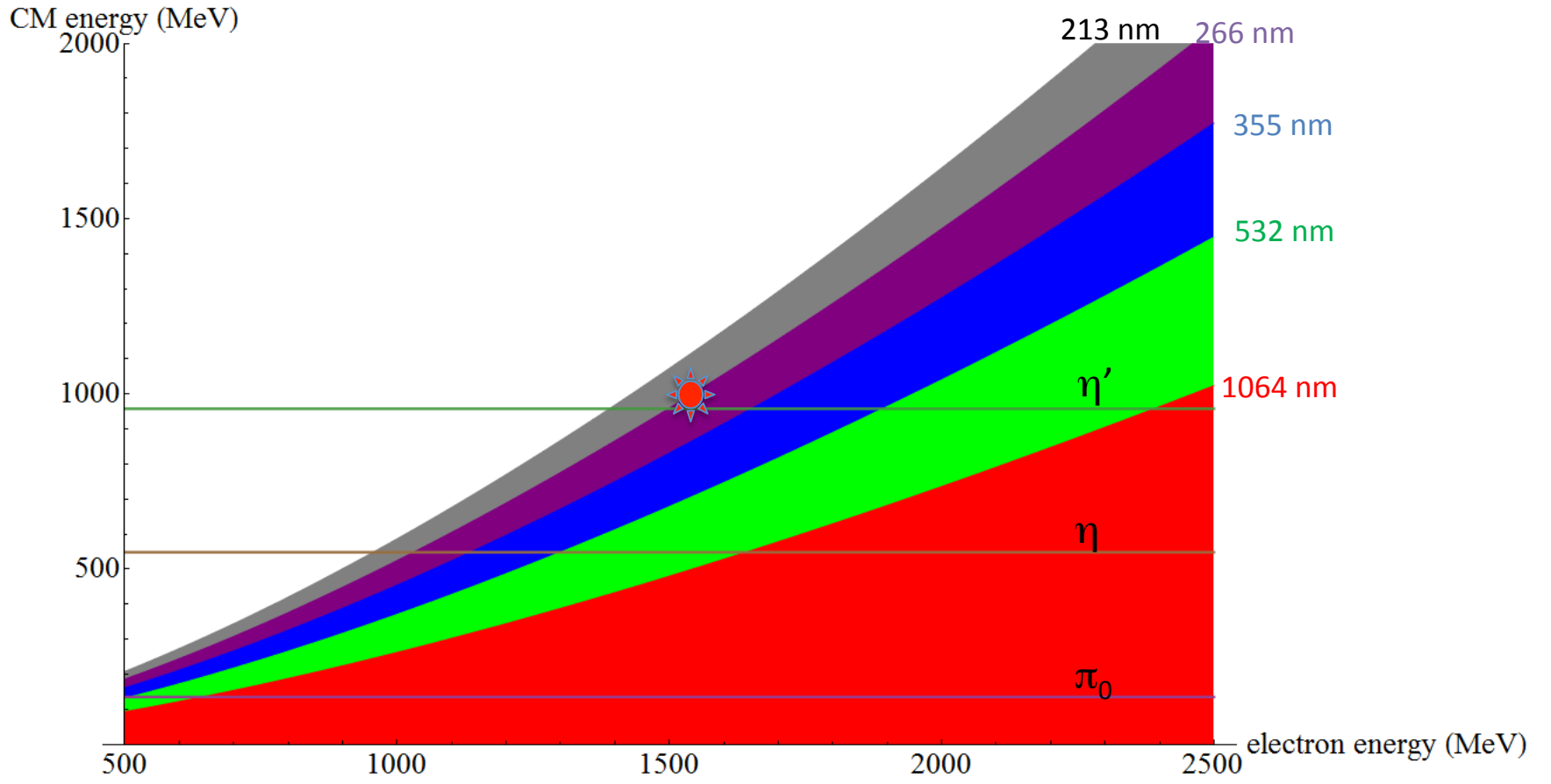

# Conceptual scheme

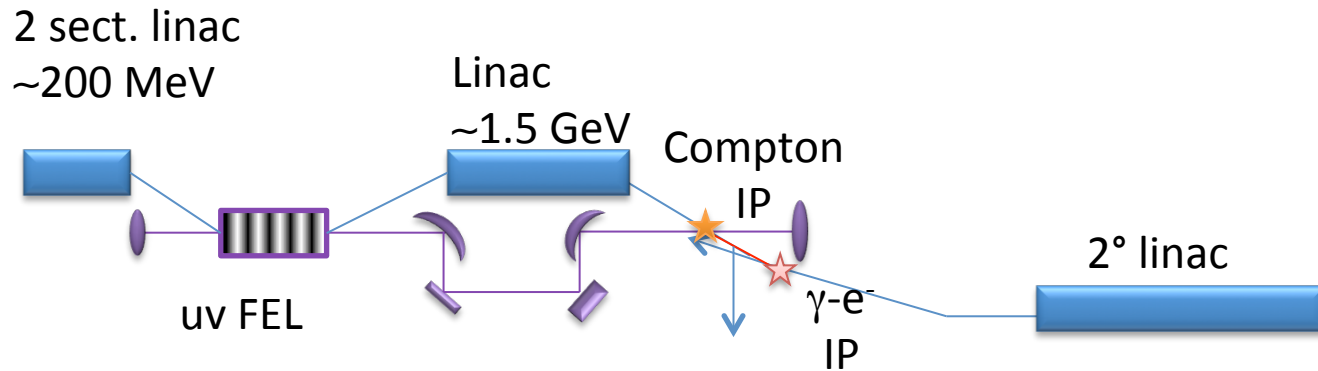

0°&45° mirrors @266 nm: >99.5%, 2J/cm<sup>2</sup>@10 ns

Undulator: 2 m, 4.8 cm period, 2.45 kG on axis  
K=1.1;  $\rho=0.0014$  ( $L_g=1.54$ m)

2 cryomodules (200 MeV) + all the other sections (up to 1 to 2 GeV)

Charge per bunch: 500 pC

Bunch time structure: macrobunch 15% DC at 100Hz, single bunch 1ps rms

Average current: 0.47 mA @1GeV, 0.28 mA @1.5GeV, 0.12 mA @2GeV



# First calculations

- FEL:
  - FEL wavelength: 266 nm
  - Electron waist: 350  $\mu\text{m}$
  - FEL intracavity intensity at saturation:  $1.3 \cdot 10^{12} \text{ W/cm}^2$  (5mJ/pulse)
- Compton
  - # of  $\gamma_{\text{compton}}$ /shot (10% bw):  $8 \cdot 10^5$
  - Electron  $\gamma$ : 3050 (1550 MeV)
  - Focus dimension: 5  $\mu\text{m}$
  - $\gamma_{\text{compton}}$  energy: 153 MeV
- $\gamma$ - $e^-$  interaction
  - Electron  $\gamma$ : 3050
  - CM energy: 977 MeV
  - IP dimension: 0.25  $\mu\text{m}$
  - Luminosity:  $3 \cdot 10^{29} \text{ cm}^{-2} \text{ s}^{-1}$  (other sources  $1.3 \cdot 10^{30} \text{ cm}^{-2} \text{ s}^{-1}$  in 1<sup>st</sup> h) x0.25 in 2<sup>nd</sup> h, x0.09 in 3<sup>rd</sup> h

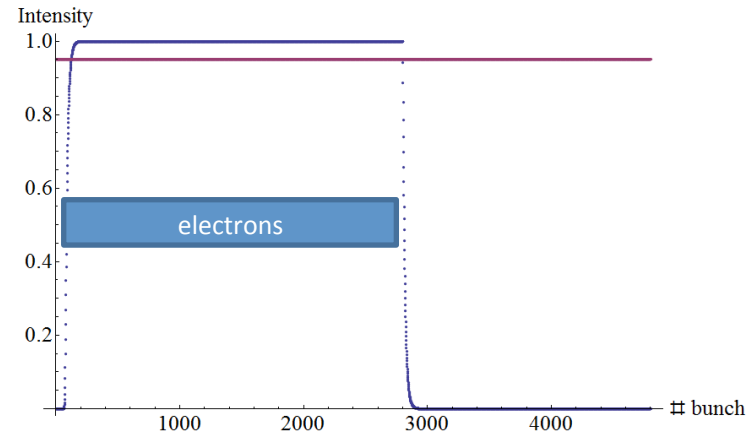

# $\gamma$ - $\gamma$ Linear Collider

The vacuum of QED poses some still unsolved challenges which are central not only in the context of field theory, but also of super-symmetry and string theory as well. The elastic photon-photon scattering offers unique opportunities to probe the nature of QED vacuum. We propose an experiment to observe photon-photon scattering in the range 1 MeV – 2 MeV CM energy, i.e., near the peak of the QED cross-section. In addition a low-energy photon-photon collider investigation could lead to the necessary technology developments and prepare the ground for a higher energy complex, while still providing a rich testing ground for QED, and, more generally, QFT.

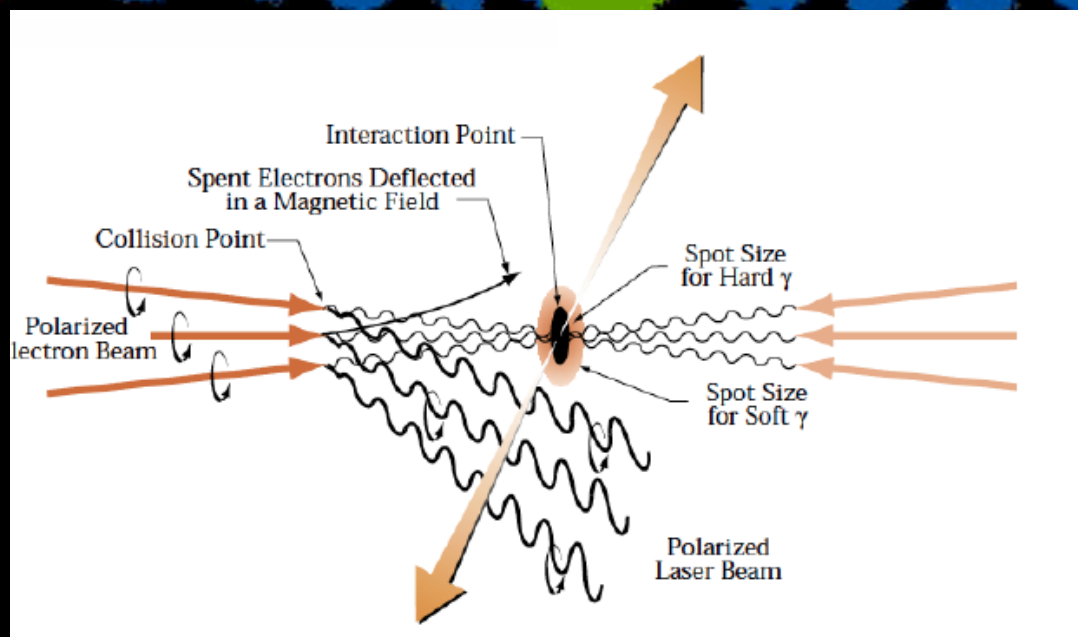

# $\gamma$ - $\gamma$ Linear Collider

The most striking failing of QFT is the huge mismatch between the measured energy density of vacuum and the energy density of the ground level of the fundamental fields which is wrong by something like 120 orders of magnitude.

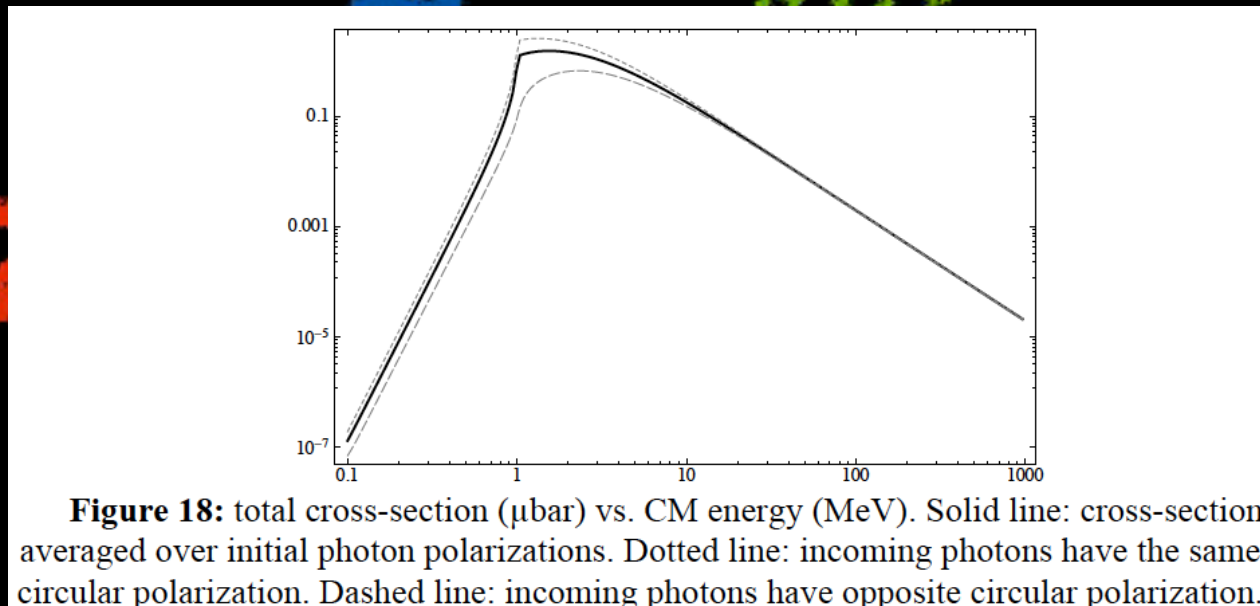

a photon-photon scattering experiment with photon energies in the 0.5-0.8 MeV range – where the cross-section is reasonably large, would be an important test of our understanding of the QED vacuum.

This experiment needs a low-energy photon-photon collider, and a photon detection apparatus which is very similar to that current PET scanners

# Luminosity and beam requirements

Parameters for ELI-NP case	Units	Thomson Compton Source	$\gamma$ - $\gamma$ collider	$e$ - $\gamma$ collider
Beam energy	[GeV]	1	1	1
Charge	[nC]	0.5	0.5	0.5
Bunch length rms	[ $\mu$ m]	300	300	125
Peak current	[A]	200	200	1600
effective Rep. rate	[Hz]	60x100	60x100	60x100
Average current	[ $\mu$ A]	3	3	3
rms spot size at collision	[ $\mu$ m]	5	1	0.25
coll. Laser eff. Power	[kW]	0.1	0.1	0.1
coll. Laser pulse energy	[J]	1	1	1
rms norm. emittance	[ $\mu$ m]	0.5	1	1
beta-funct. at coll. (1 GeV)	[ $\mu$ m]	100	2	0.125
# $\gamma$ /shot		$6.0 \cdot 10^8$		
# $\gamma$ /s	[s <sup>-1</sup> ]	$3.6 \cdot 10^{12}$		
Luminosity (coll)	[cm <sup>-2</sup> s <sup>-1</sup> ]		$1.7 \cdot 10^{28}$	$1.4 \cdot 10^{30}$

Parameters for SC-qCW case	Units	Thomson Compton Source	$\gamma$ - $\gamma$ collider	$e$ - $\gamma$ collider
Beam energy	[GeV]	1	1	1
Charge	[nC]	0.5	0.5	0.5
Bunch length rms	[ $\mu$ m]	300	300	125
Peak current	[A]	200	200	1600
Effective Rep. rate	[Hz]	9400x100	9400x100	9400x100
Average current	[ $\mu$ A]	470	470	470
rms spot size at collision	[ $\mu$ m]	5	1	0.25
coll. Laser eff. Power	[kW]	1000	1000	1000
coll. Laser pulse energy	[J]	0.01	0.01	0.01
rms norm. emittance	[ $\mu$ m]	0.5	1	1
beta-funct. at coll. (1 GeV)	[ $\mu$ m]	100	2	0.125
# $\gamma$ /shot		$6.0 \cdot 10^6$		
# $\gamma$ /s	[s <sup>-1</sup> ]	$5.6 \cdot 10^{12}$		
Luminosity (coll)	[cm <sup>-2</sup> s <sup>-1</sup> ]		$2.7 \cdot 10^{26}$	$2.2 \cdot 10^{30}$

# $e^+ e^-$ Linear Collider

An electron-positron collider with luminosity of  $10^{32} \text{ cm}^{-2}\text{s}^{-1}$  with center of mass energy ranging from the mass of the  $\phi$ -resonance  $1 \text{ GeV}$  up to  $\sim 3.0 \text{ GeV}$ , would complement high-energy experiment at the LHC and future linear collider (ILC). Such a machine can easily collect an integrated luminosity of about  $5 \text{ fb}^{-1}$  in a few years of data taking.

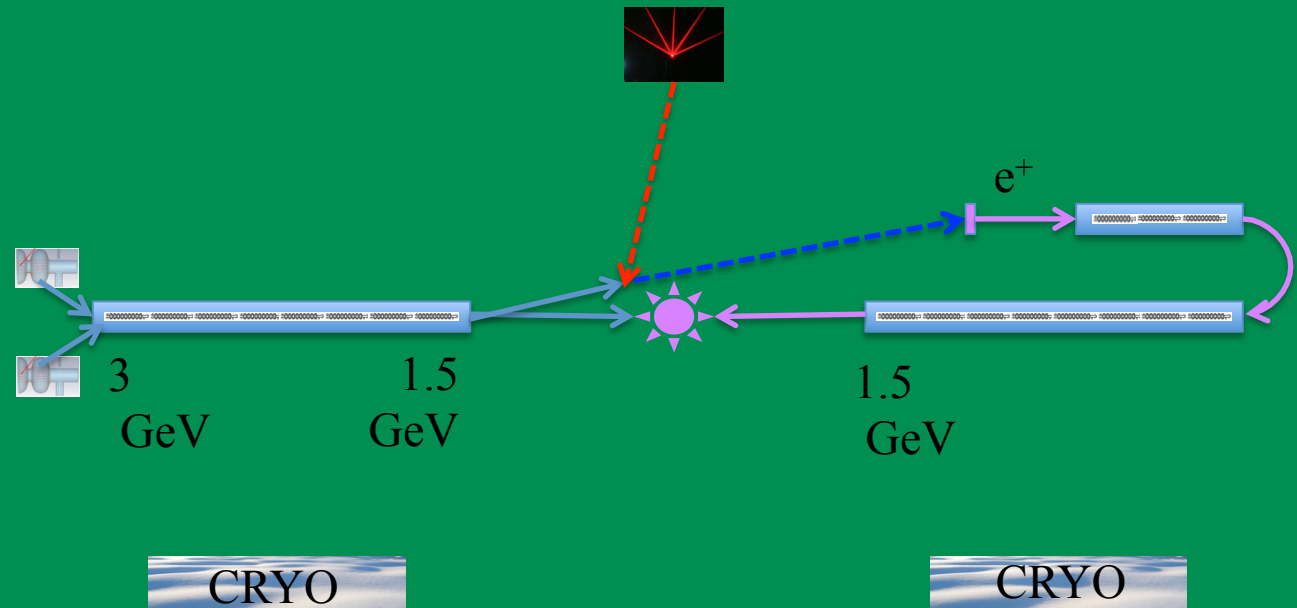

This will allow one to measure the  $e^+e^-$  cross section to hadrons with a total fractional accuracy of 1%, a level of knowledge that has relevant implications for the determination of SM observables, like, the  $g-2$  of the muon and the effective fine-structure constant at the  $M_Z$  scale. The latter are, through quantum effects, sensitive to possible bSM physics at scales of the order of hundred GeV or TeV.

A primary effect of the electron-positron interaction is an enhancement of the luminosity due to the **pinch effect**, i. e. the reduction of the cross section of both beams occurring at the IP due to **self focusing forces** that is included in the luminosity definition through the factor  **$H_D$** .

$$L = \frac{n_b N_e^2 f_{rep}}{4\pi\sigma_x^* \sigma_y^*} \times H_D = \langle I \rangle \times \frac{N_e}{4\pi\sigma_x^* \sigma_y^*} \times H_D$$

$$H_D = \frac{L}{L^*} = \frac{\sigma_x^* \sigma_y^*}{\sigma_x \sigma_y}$$

$$D_{x,y} \equiv \frac{2N_e r_e}{\gamma} \frac{\sigma_z}{\sigma_{x,y} (\sigma_x + \sigma_y)}$$

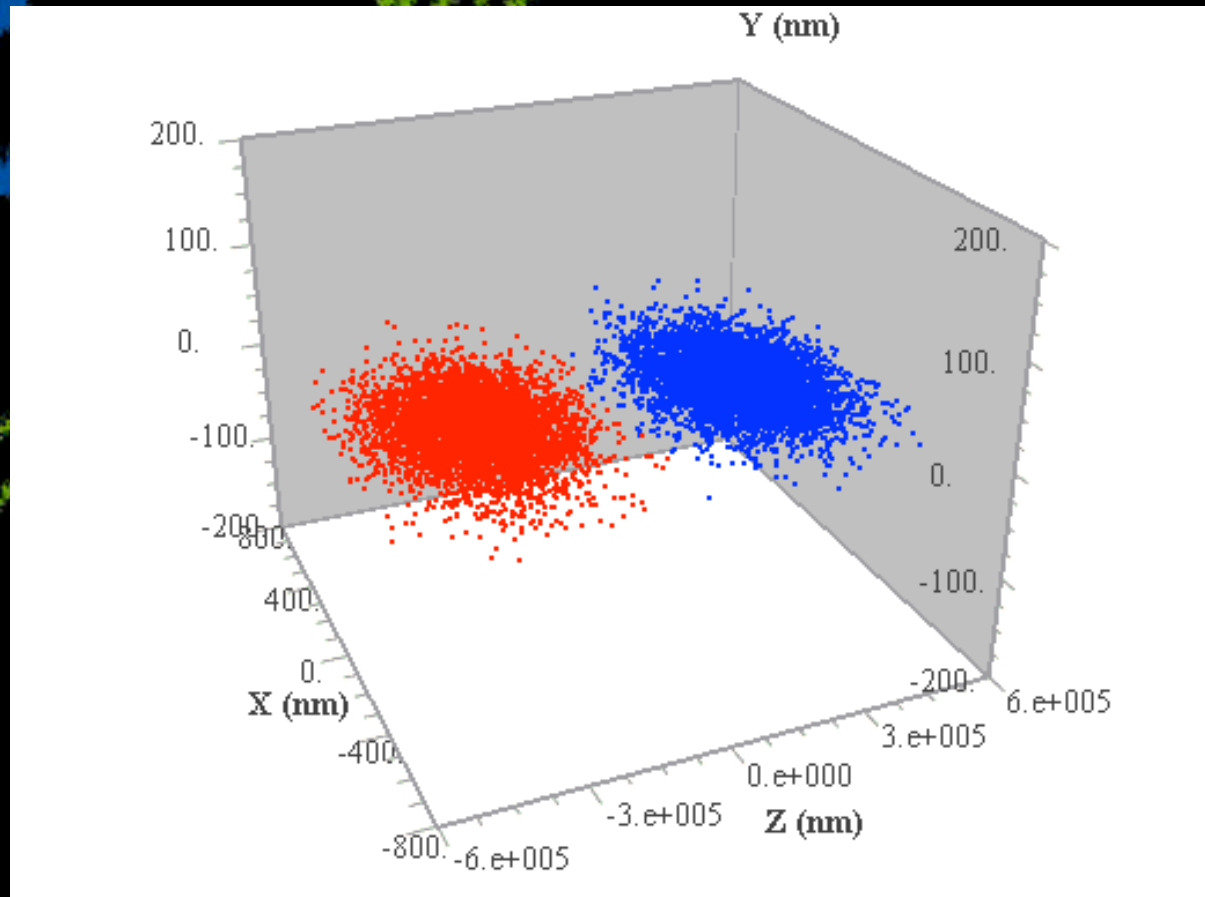

$$\sigma''_{pos,x} + \frac{k_{el}^2}{\gamma} \sigma_{pos,x} = \frac{\epsilon_{pos,n}^2}{\gamma^2 \sigma_{pos,x}^3}$$

$$k_{el}^2 = \frac{4I_{el}}{I_A \sigma_{el,x}^2}$$

$$\sigma_{x,pos} = 2 \sqrt{\frac{\epsilon_{n,pos}}{\sqrt{\gamma} k_{el}}}$$

Under the previous condition the positron beam spot size remains constant during the interaction due to the balance between its own defocusing emittance pressure and the counter-propagating electron beam focusing effect.

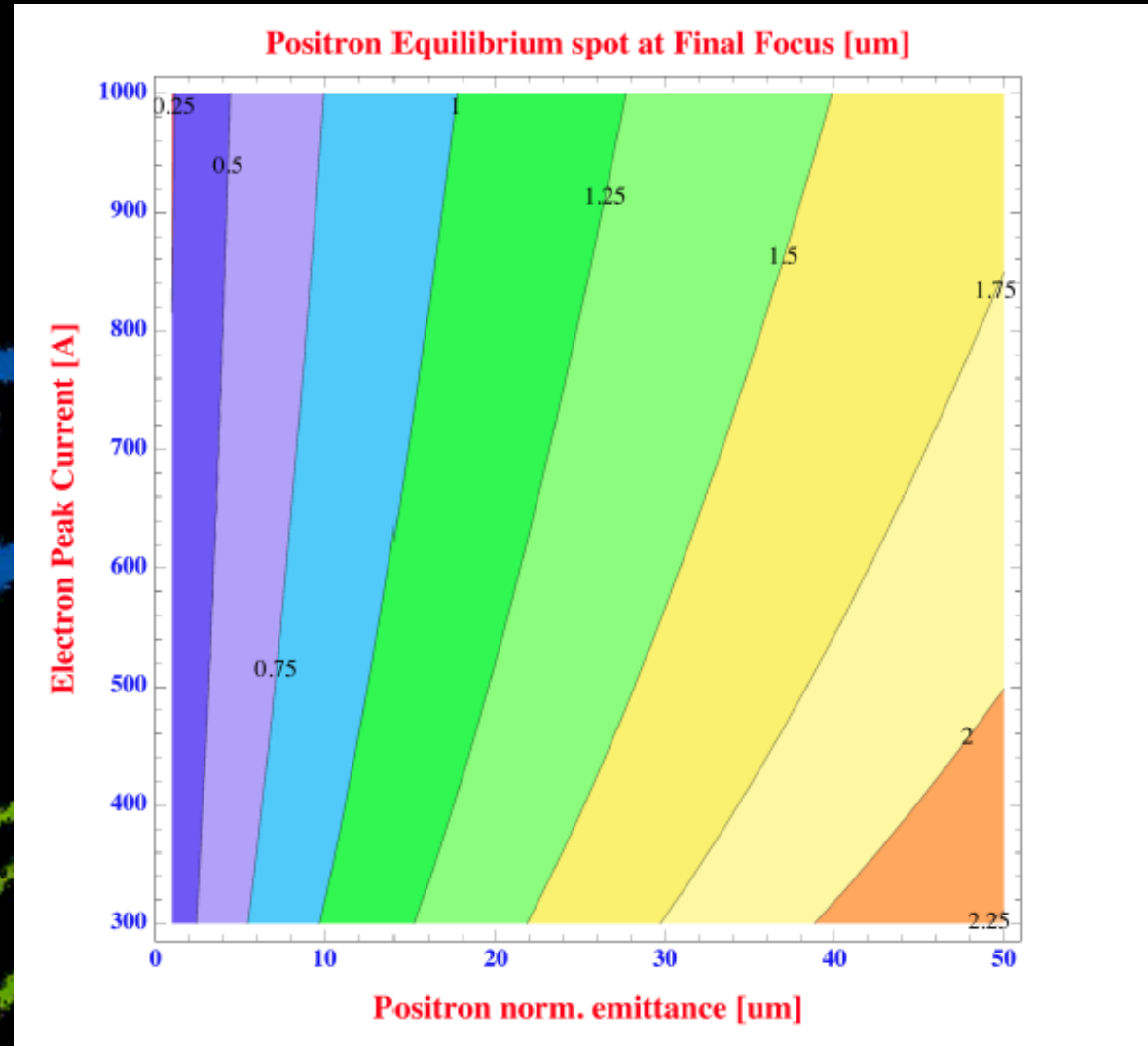

Parameters	Units	Electrons $\times$ Electrons	Electrons $\times$ Positrons	Reduced Positron quality
Beam energy	[GeV]	1	1	1
Beam power	[MW]	1	1	0.4
AC power	[MW]	1.9	1.9	1.3
Charge	[nC]	0.2	2	0.8
Bunch length rms	[ $\mu\text{m}$ ]	500	675	450
Peak current	[A]	120	888	533
Rep. rate	[MHz]	5	0.5	0.5
Average current	[mA]	1	1	0.4
Transverse rms spot at IR	[ $\mu\text{m}$ ]	0.5	1.5	1.5
Norm. emittance	[ $\mu\text{m}$ ]	1	2	10
Beta at IR	[mm]	0.5	2.6	0.45
Aspect ratio	A	1	0.3	1
Disruption parameter	D	-3.5	5.3	1.4
Beam-strahlung parameter	$\delta_e$	$\sim 10^{-7}$	$\sim 10^{-7}$	$\sim 10^{-7}$
Luminosity enhancement factor	$H_D$	(<) 1	5.8	1.3
Luminosity	$\text{cm}^{-2}\text{s}^{-1}$	$\sim 2.5 \cdot 10^{32}$	$1.6 \cdot 10^{33}$	$\sim 1.1 \cdot 10^{32}$



Parameters Pulsed Operation	Units	Electrons × Electrons	Electrons × Positrons	Reduced Positron quality
Beam energy	[GeV]	1.5	1.5	1.5
Linac Active Length	[m]	200	200	200
Accelerating gradient	[MV/m]	11.29	11.29	11.29
Beam train duration	[ms]	0.93	0.93	0.93
<b>Beam rep. rate in the train</b>	<b>[MHz]</b>	<b>26</b>	<b>5</b>	<b>5</b>
N. bunches in the train		24180	4650	4650
RF rep. rate	[Hz]	100	100	100
Beam Duty Cycle	[%]	9.3	9.3	9.3
Beam power	[MW]	0.725	1.4	0.588
AC power	[MW]	0.839	1.5	0.671
Charge	[nC]	0.200	2	0.8
Bunch length rms	[μm]	270	1013	675
Peak current	[A]	222	592	355
<b>Average current pulsed</b>	<b>[mA]</b>	<b>5.2</b>	<b>10</b>	<b>4</b>
<b>Average current</b>	<b>[mA]</b>	<b>0.484</b>	<b>0.930</b>	<b>0.372</b>
Transverse rms spot at IR	[μm]	0.3	1.5	1.5
Norm. emittance	[μm]	1	2	10
Beta at IR	[mm]	0.270	3.4	0.675
Aspect ratio	A	1	0.3	1
Disruption parameter	D	3.5	5.3	
Beam-strahlung parameter	$\delta_e$	$\sim 10^{-0}$	$\sim 10^{-1}$	$\sim 10^{-1}$
Luminosity enhancement factor	$H_D$	0.42	5.8	1.0
Luminosity	$\text{cm}^{-2}\text{s}^{-1}$	$1.4 \cdot 10^{32}$	$1.5 \cdot 10^{33}$	$\sim 1.0 \cdot 10^{32}$

# Experimental and Theoretical Progress LC Final Focus Design and ATF2 Facility

**Andrei Seryi**

John Adams Institute for Accelerator Science

*for the ATF/ATF2 international collaboration*



# Factors driving design of BDS

- **Final Doublet chromaticity**
  - local compensation of chromaticity
- **Beam-beam effects**
  - background, IR and extraction design
- **SR emittance growth in BDS bends**
  - weak and long
- **Halo collimation**
  - survivability of spoilers
- **Beam diagnostics**
  - measurable size at laser wires
- ...

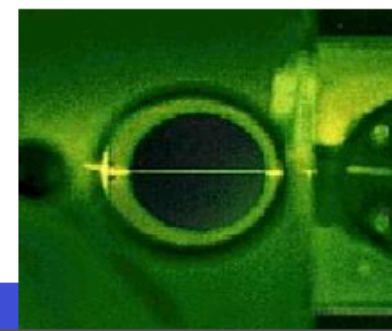
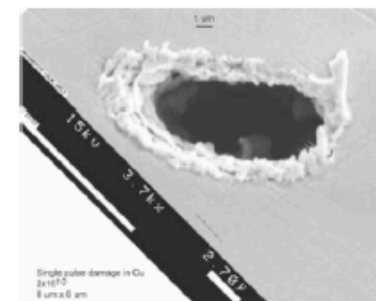
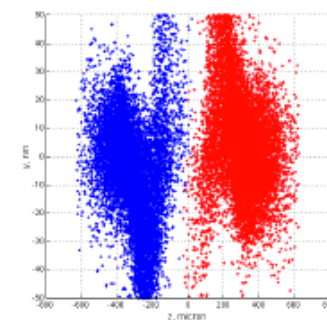
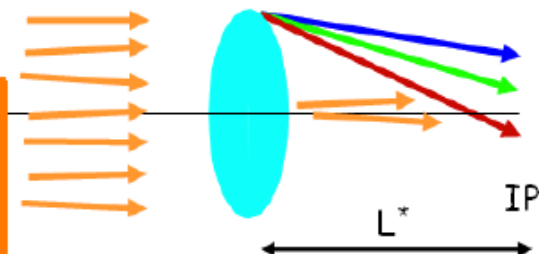

ATF2 beam line

ATF extraction line

Final Focus System

$\beta$  matching

Diagnostic

Reconfiguration of extraction line for reduction of dispersion

57000

41179.42

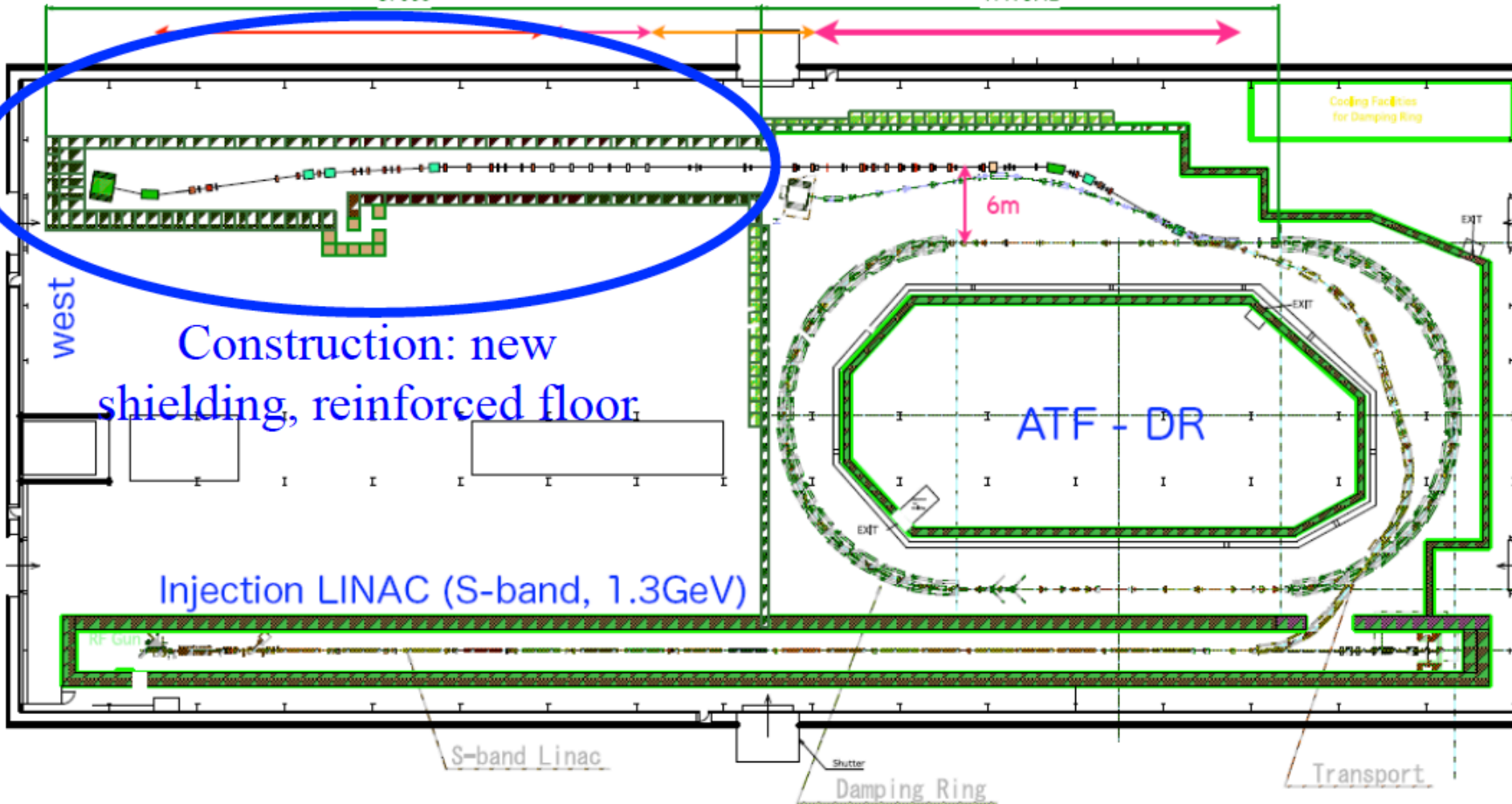

Construction: new shielding, reinforced floor

Injection LINAC (S-band, 1.3GeV)

ATF - DR

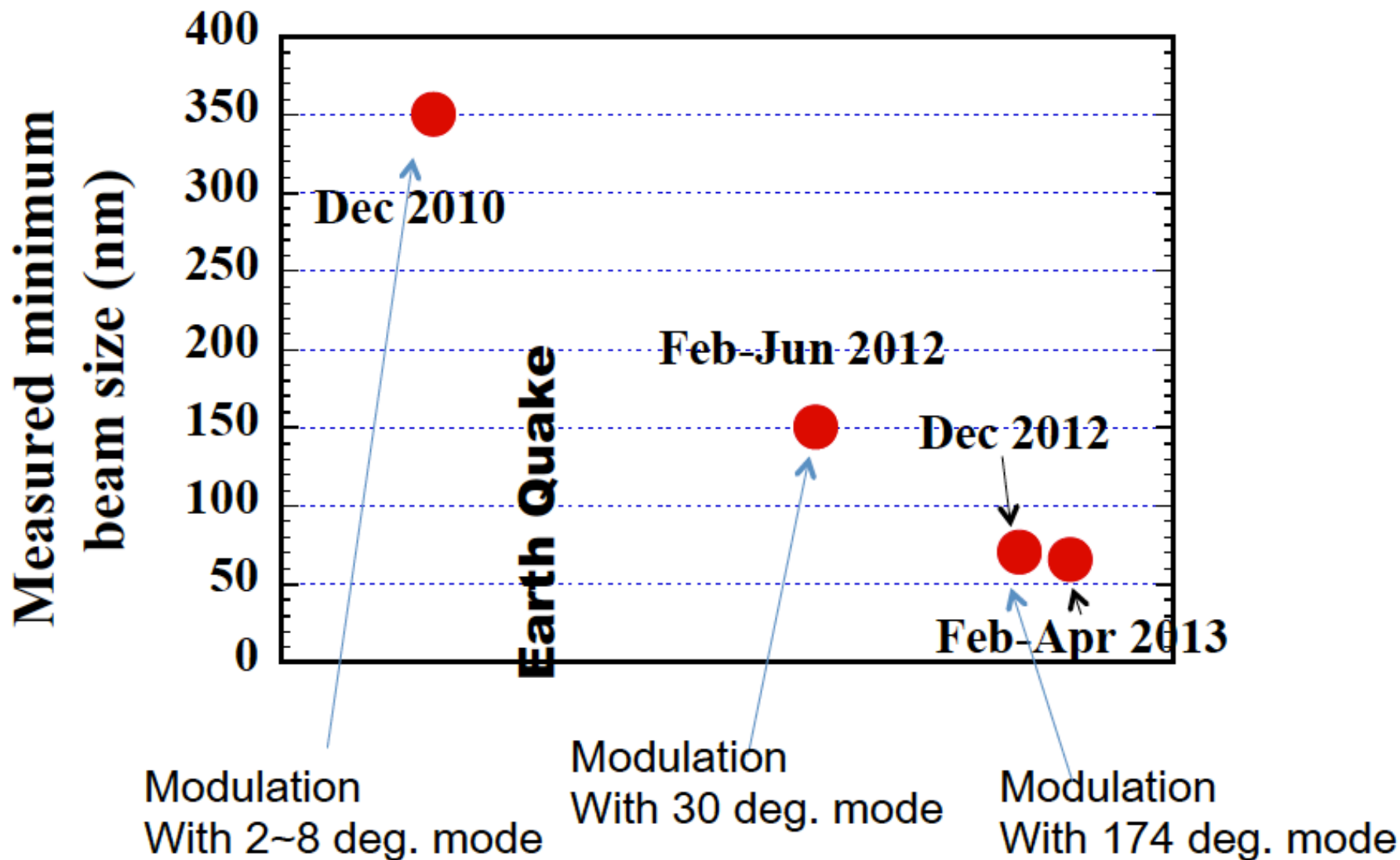

# Classical sources, scheme

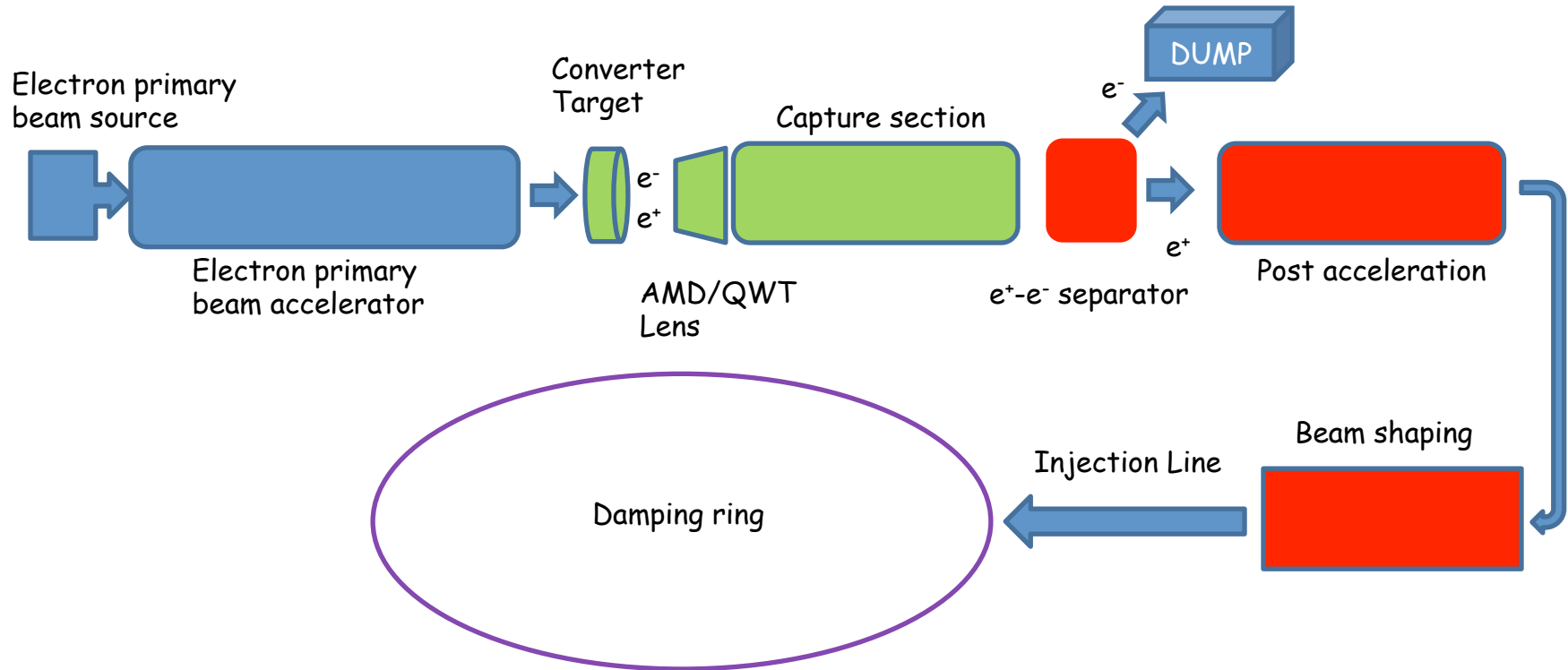

Can the DR be considered as a part of the positron source?

In my opinion it can. Its parameters result from the positron source and vice versa

# Gamma separation: ILC Positron source schematic. Undulator Undulator and laser => Polarization

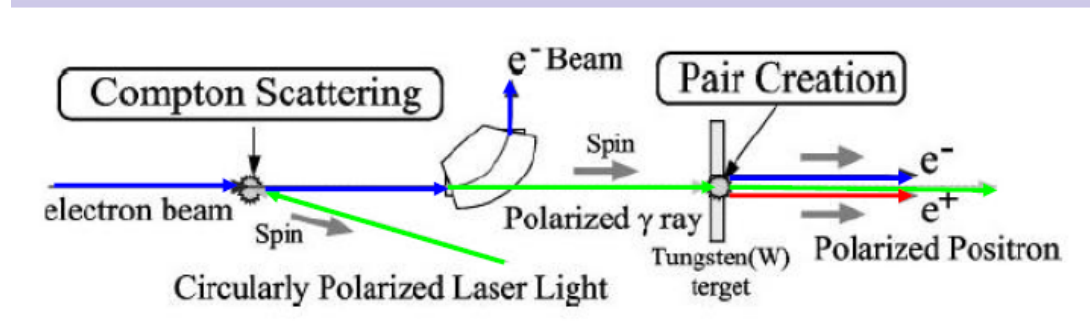
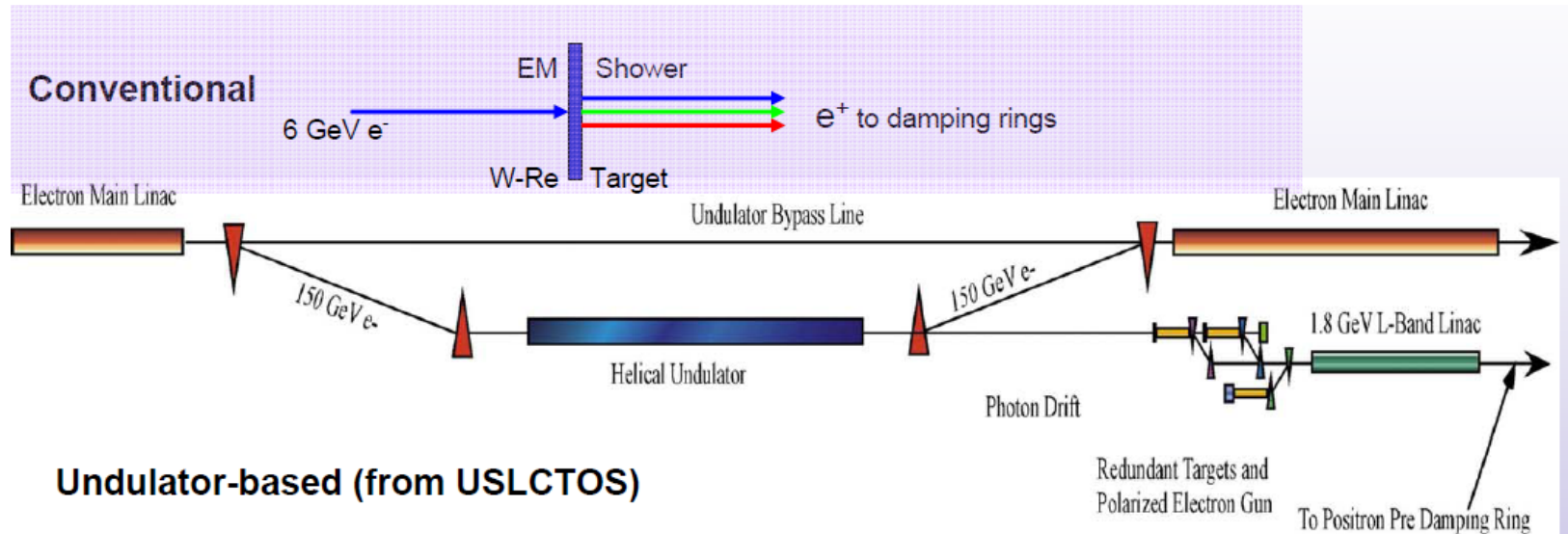

Balakin, Mikhailichenko

# Gamma separation CLIC Hybrid Source

## 1) Channeling

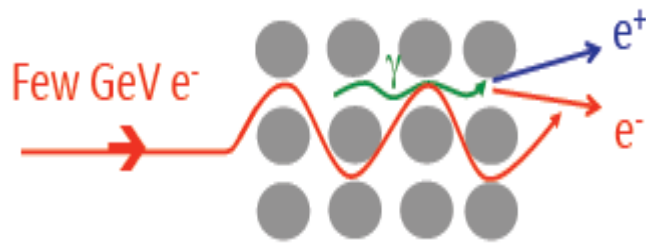

**PEDD = Peak Energy Deposition Density**  
 $1 \text{ GeV/cm}^3 = 8.3 \times 10^{-12} \text{ J/g}$  for W  
 Train of 312 bunches =  $2.34 \times 10^{12} e^-$   
 $\sigma$  (e- spot) = 2.5 mm

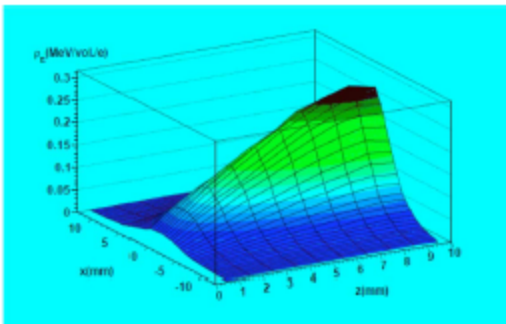

R. Chehab  
 V. Strakhovenko  
 A. Variola

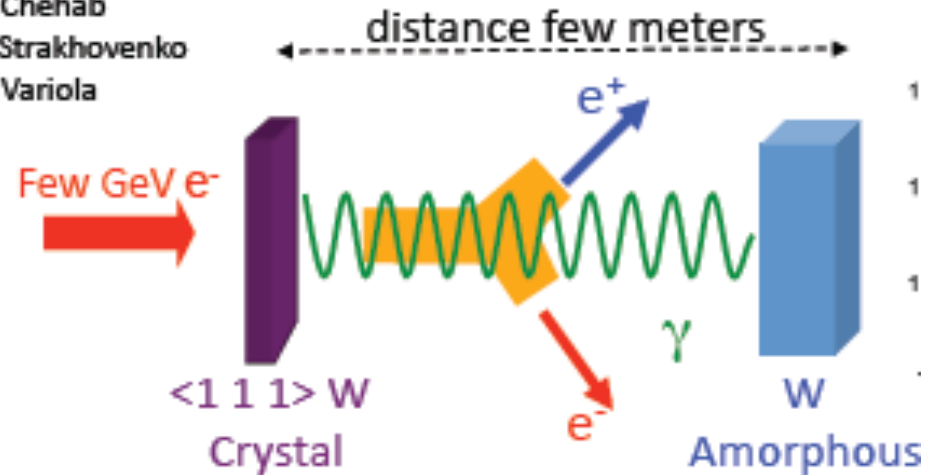

### Strakhovenko code

Mesh volume =  $0.094 \text{ mm}^3$   
 (ring shape)  
 PEDD =  $0.040 \text{ MeV / vol / e}^-$   
 PEDD =  $0.427 \text{ GeV/cm}^3/\text{e}^-$   
 PEDD =  $15.5 \text{ J/g}$

### GEANT4 results:

Mesh volume =  $0.25 \text{ mm}^3$   
 (parallelepiped shape)  
 PEDD =  $0.285 \text{ MeV / vol / e}^-$   
 PEDD =  $1.14 \text{ GeV/cm}^3/\text{e}^-$   
 PEDD =  $22.14 \text{ J/g}$



**Table 12:** Comparison between Conventional and ICS positron source performances

	<b>Conventional</b>	<b>ICS based</b>
RMS source size	400 $\mu\text{m}$	50 $\mu\text{m}$
N. particles/driving pulse	one 600 MeV electron	one 60 MeV photon
Target thickness	$6X_0$	$0.4X_0$
RMS transverse momentum	5 MeV	1 MeV
RMS emittance	0.001 m rad	$50 \cdot 10^{-6}$ m rad
N. positrons/pulse	1	0.4

For the peak brightness the main advantage of driving the conversion directly with a photon beam relies on the possibility of using thinner targets. The emittance of the positron beam emerging from the target is determined by the source size and the beam divergence.

# IRIDE road map

- **March → June – Working Groups Meeting with int. experts**
- **July 17 – White Book ready**
- **By the end of 2013 IRIDE approval?**

A tropical beach scene with a vibrant rainbow arching across a clear blue sky. The foreground shows a sandy beach with several green lounge chairs and white umbrellas. Palm trees line the right side of the beach, and the turquoise ocean extends to the horizon. The text "Thank you" is overlaid in the center, with each letter in a different color corresponding to the rainbow's spectrum.

Thank you

# ILC-CLIC, Compton backscattering

T. Omori et al., Nucl. Inst. Meth. A500 (2003) 232. => CO2 lasers  
 S.Araki et al. arXiv:physics/0509016v2 [physics.acc-ph] 15 Sep 2005 => FP cavities  
 I Pogorelski, V Yakimenko, PAC 2007 proceedings, Albuquerque  
 I Chaikovska PhD Thesis

A laser can be seen, by the particle, as a 'light' undulator. The equation of motion is the same as that of a helical undulator... so is the radiation field...linear and non linear

Pro : independent source (main beam few GeV), less thermal stress danger, easy in polarization handling

Main problem: for these applications the Compton cross section is extremely low....

Schemes :

CW => Compton Ring - ERL (FP cavities, high average power laser /stacking, multiple IPs)

Pulsed => Compton LINAC CO2 laser, regenerative, recirculator cavity - single shot

Alternative solutions for ILC and CLIC. A lot of R&D is needed....

