

A pedagogical Introduction to FLUKA + hands-on tutorial

Daniele Calzolari (CERN SY-STI-BMI)

*with material from previous lectures by G. Lerner, A. Lechner, F. Salvat Pujol,
F. Cerutti*

An overview of FLUKA

<https://agenda.infn.it/event/51984/>

Roma 4/5/2026





1. Get FLUKA & Flair to work

Step 0: get FLUKA

- After a successful registration, you can download the binaries or FLUKA from the official website (<https://fluka.cern/download/latest-fluka-release>)

Binary libraries for GNU/Linux:

Download

gfortran 8, 64 bits (.tgz)

Download

gfortran 8, 64 bits (.rpm)

Download

gfortran 8, 64 bits (.deb)

Download

gfortran>=9, 64 bits (.tgz)

Download

gfortran>=9, 64 bits (.rpm)

Download

gfortran>=9, 64 bits (.deb)

I chose this for my machine!
(Ubuntu 24.04.3 LTS via WSL)

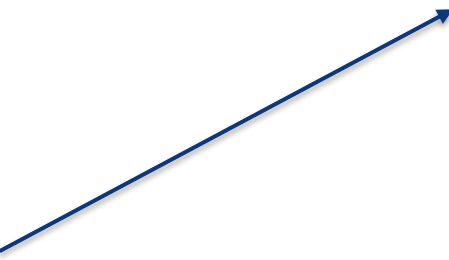

Step 0: get FLUKA (... and a lazy one-liner)

```
wget https://flair.cern/download/flair-3.4-5.2.tgz
wget https://flair.cern/download/flair-geoviewer-3.4-5.2.tgz
tar xzvf flair-3.4-5.2.tgz
tar xzvf flair-geoviewer-3.4-5.2.tgz
rm flair-geoviewer-3.4-5.2.tgz
rm flair-3.4-5.2.tgz
cd flair-geoviewer-3.4
make -j 8
make install DESTDIR=../flair-3.4
cd ..

tar -xvf fluka-4-5.1.x86-Linux-gfor9.tgz
cd fluka4-5.1/src/
make -j 8
cd ../
wget https://flukafiles.web.cern.ch/flukafiles/neutron/fluka_pw_jeff-3.3-1-1.tar.gz
tar xvfz fluka_pw_jeff-3.3-1-1.tar.gz
rm fluka_pw_jeff-3.3-1-1.tar.gz
cd ..

# Can be useful to have an alias like this:
alias myflair=$(pwd)/flair-3.4/flair
```

Download,
extract and
install flair

Compile FLUKA
and download
neutron cross
section

Consider doing it for your laptop!

Flair: the first rendezvous

- If all of that was successful, you can invoke flair, and it should open. First sanity checks:
 - The geoviewer works
 - The Flair (and FLUKA) versions are correct
- The first time you open flair, you should check that the FLUKA path is correct

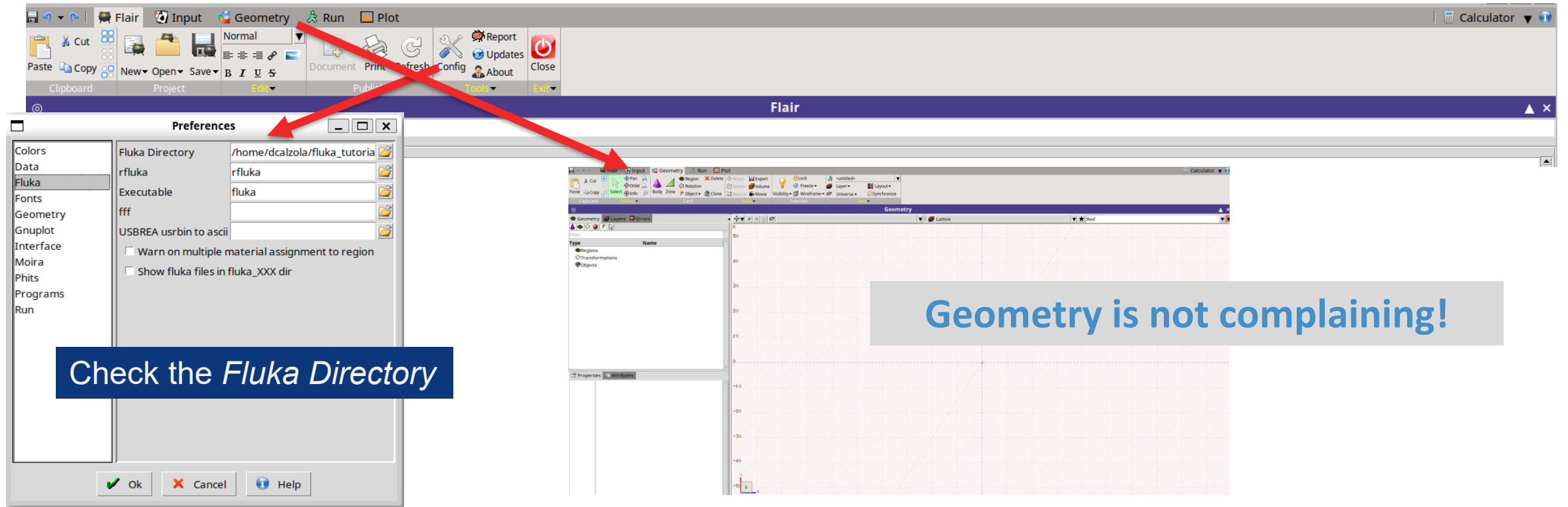



1. Objectives of today

How we are going to work

- On your computer you should be able to access to a working FLUKA and a (obsolete) Flair version.
- We will go through an example at the time together. Do not spoil yourself the solutions just yet.

Tasks

- Today we will try to perform some simple simulations:
 1. **Proton Bragg peak**: setup from scratch & visualization (~15 min)
 2. **Other particles & energies**: particle fluence comparisons (~15 min)
 3. **Target activation**: measuring induced radioactivity (~15 min)
- Interesting topics I will not talk about:
 - User routines (but you can find more information in the last [advanced course](#))
 - Advanced physics options (photonuclear, electronuclear, ...)
 - Event by event scoring
 - EM fields
 - Biasing

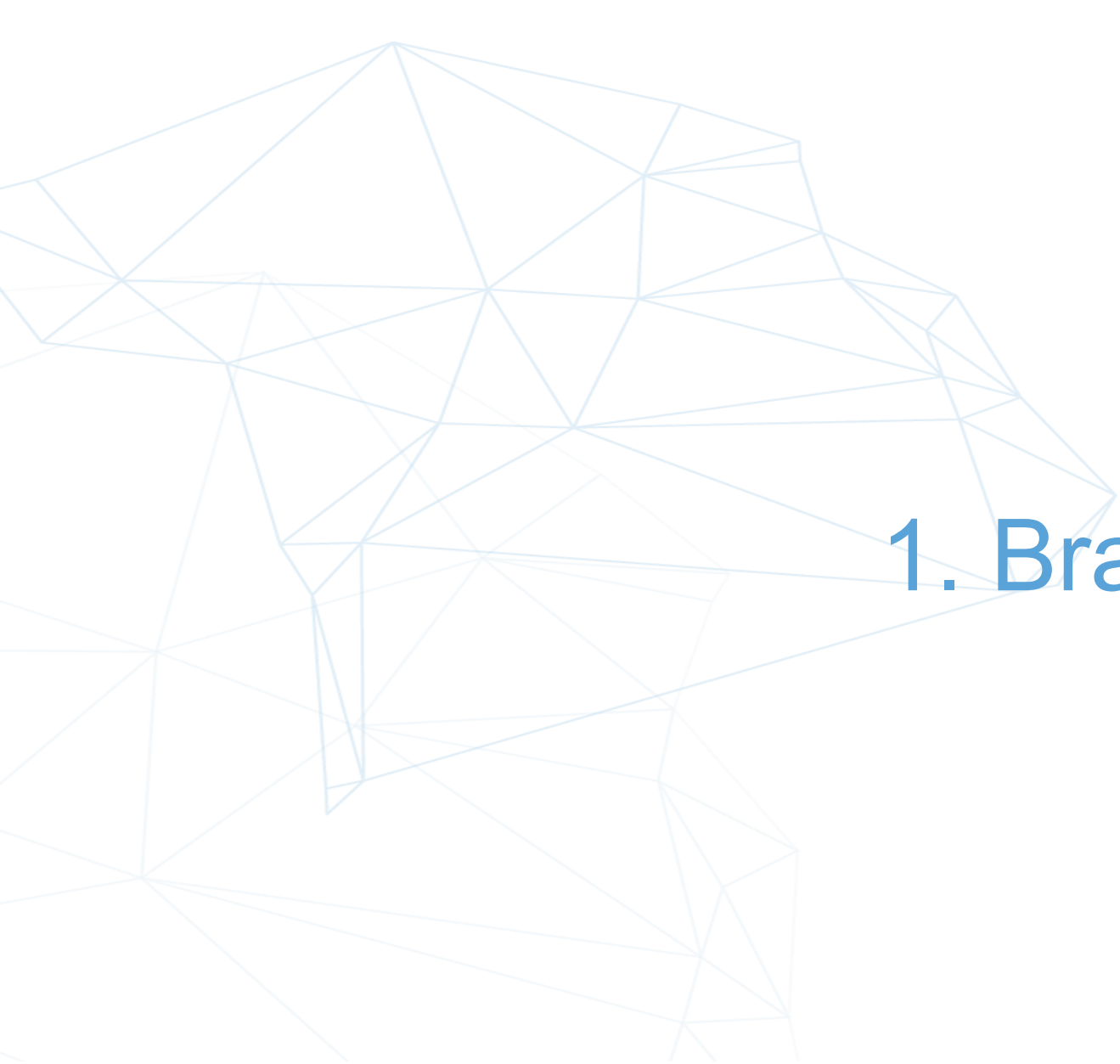

1. Bragg peak simulation

1. What is the Bragg peak

- Charged particles deposit most energy at the **end of their range**
 - As the proton slows down → energy loss increases ($dE/dx \uparrow$)
 - **Sharp peak** just before stopping, then rapid drop
- **Key features:**
 - Low dose at entrance
 - Sharp, localized peak near stopping point
 - Rapid drop to zero after the peak
- Particularly useful for radiation therapy:
 - Precise dose localization
 - Sensitive to beam energy → controls penetration depth

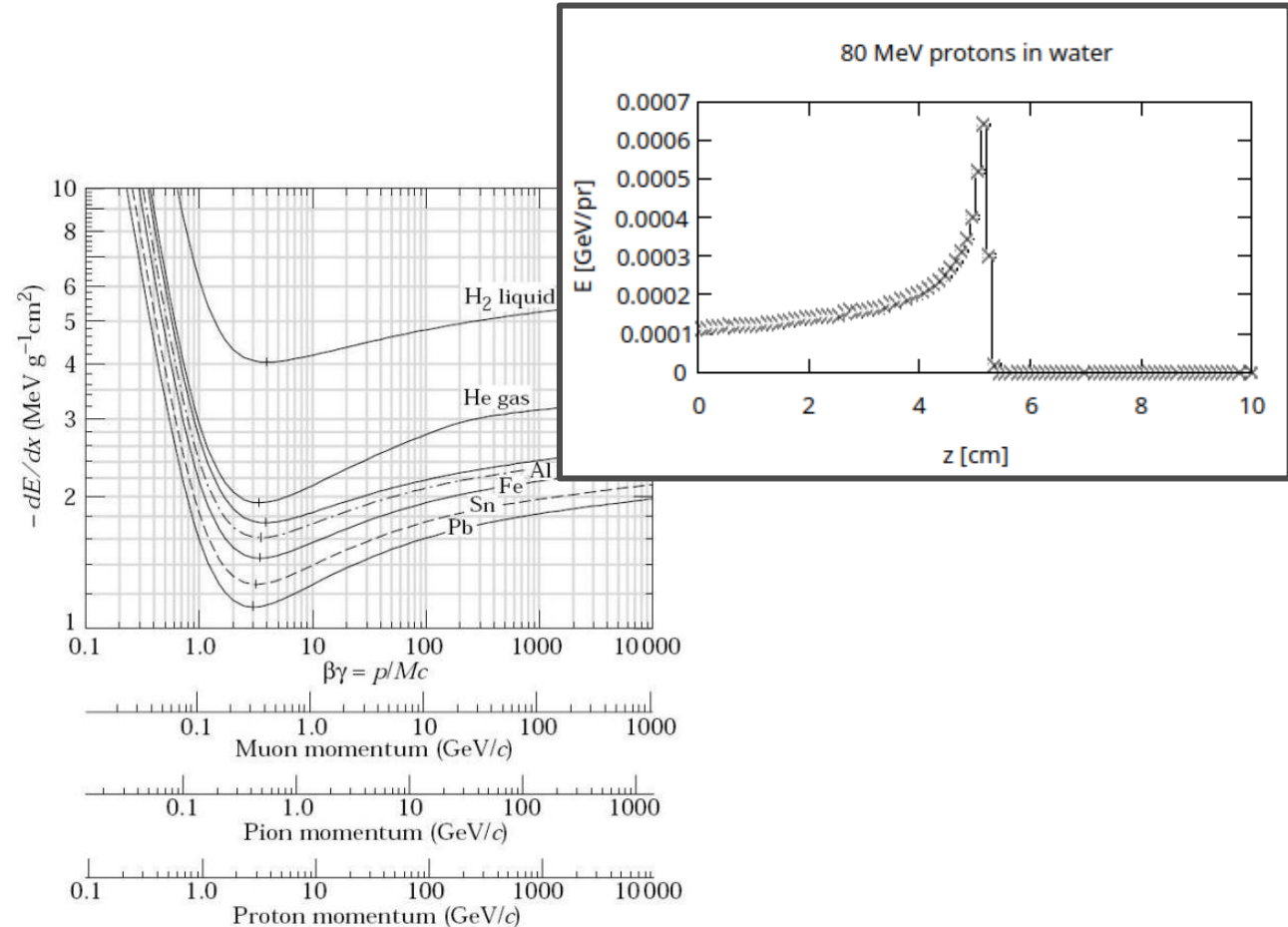

1. Bragg peak simulation: setup

- Flair helps us here: let's create a new inputfile 'basic'

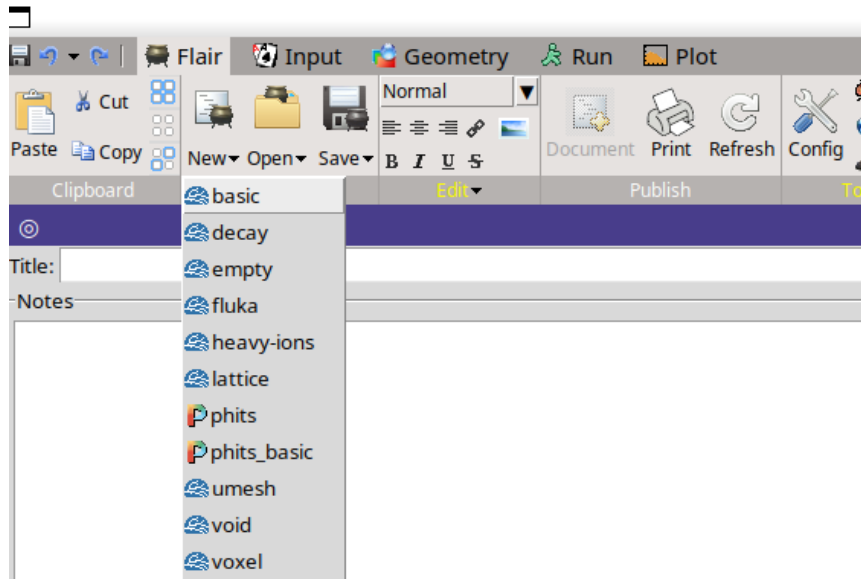

Non-geometry cards

```
T TITLE
Set the defaults for precision simulations
DEFAULTS : PRECISIO v
Define the beam characteristics
BEAM Beam: Momentum v p: Part: v
      Δp: Flat v Δp: Δφ: Flat v Δφ:
      Shape(X): Rectangular v Δx: Shape(Y): Rectangular v Δy:
Define the beam position
BEAMPOS x: y: z:
         cosx: cosy: Type: POSITIVE v
.....1.....2.....3.....4.....5.....6.....7..
ASSIGNMAT Mat: BLCKHOLE v Reg: BLKBODY v to Reg: v
          Mat(Decay): v Step: Field: v
ASSIGNMAT Mat: VACUUM v Reg: VOID v to Reg: v
          Mat(Decay): v Step: Field: v
ASSIGNMAT Mat: COPPER v Reg: TARGET v to Reg: v
          Mat(Decay): v Step: Field: v
Set the random number seed
RANDOMIZE Unit: 01 v Seed:
Set the number of primary histories to be simulated in the run
START No.: Core: v
      Time: Report: default v
STOP
```

1. Bragg peak simulation: geometry

```
GEOBEGIN
  Accuracy:
  Geometry:
  Option:
  Out:
  Paren:
  Fmt: COMBNAME

  Title:
  Black body
  SPH blkbody      x: 0.0      y: 0.0      z: 0.0
                  R: 100000.0

  Void sphere
  SPH void         x: 0.0      y: 0.0      z: 0.0
                  R: 10000.0

  Cylindrical target
  RCC target      x: 0.0      y: 0.0      z: 0.0
                  Hx: 0.0    Hy: 0.0    Hz: 10.0
                  R: 5.0

END
  Black hole
  REGION BLKBODY      Neigh: 5
  expr: +blkbody -void
  Void around
  REGION VOID         Neigh: 5
  expr: +void -target
  Target
  REGION TARGET      Neigh: 5
  expr: +target

END
GEOEND
```

Geometry cards

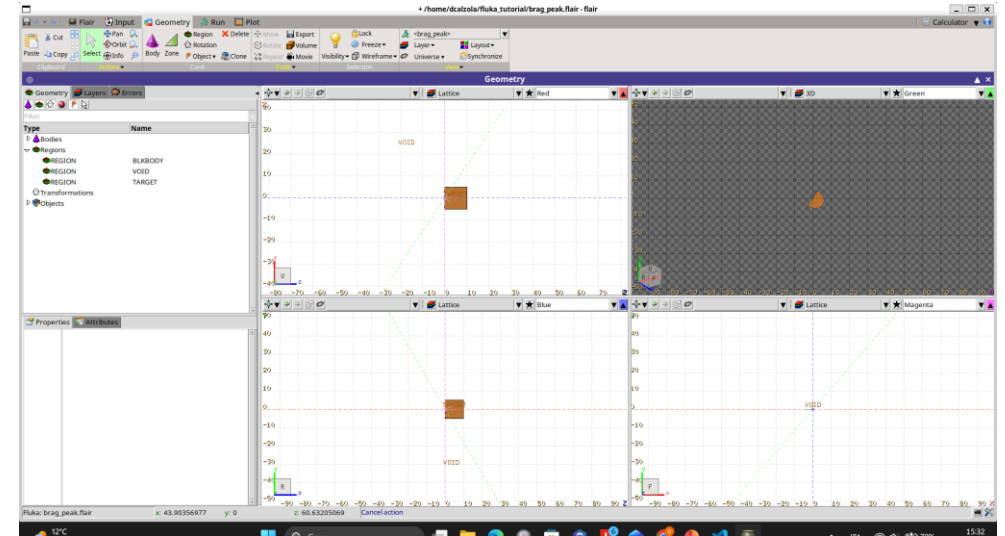

- Extremely simple geometry: cylinder in vacuum
- No need to change it for this example

1. Bragg peak simulation: finalize inputfile

- Few actions are needed before launching the simulation:
 - Set up the correct beam with **BEAM** card. We want to start with **80 MeV protons** (hint: FLUKA uses GeV as unit of measure of energy)
 - Check that we are happy with the default **PRECISION**
 - Modify target material to water
 - Add scoring. For this, we want to score on a grid the energy deposition. Use a **USRBINs** scoring

1. Bragg peak simulation: finalize inputfile

- Few actions are needed before launching the simulation:
 - Set up the correct beam with **BEAM** card. We want to start with **80 MeV protons** (hint: FLUKA uses GeV as unit of measure of energy)
 - Check that we are happy with the default **PRECISION**
 - Modify target material to water
 - Add scoring. For this, we want to score on a grid the energy deposition. Use a **USRBINs** scoring

```
Define the beam characteristics
* BEAM                      Beam: Energy ▼          E: 0.08          Part: PROTON ▼
    Δp: Flat ▼              Δp:                  Δφ: Flat ▼      Δφ:
    Shape(X): Rectangular ▼ Δx:                  Shape(Y): Rectangular ▼ Δy:

* USRBIN                    Unit: 21 BIN ▼          Name: energy
    Type: R-Φ-Z ▼          Rmin: 0           Rmax: 5          NR: 50
    Part: ENERGY ▼       X: 0              Y: 0             NΦ: 0
                          Zmin: 0           Zmax: 10         NZ: 100
```

Modified BEAM card

Added USRBIN

1. Bragg peak simulation: run

- We will run FLUKA directly from Flair. I suggest those 2 optional passages:
 - Create a folder where you want to run this set of simulations
 - Create the *Run* specifying 1000 primaries in 4 spawns (or cycles)

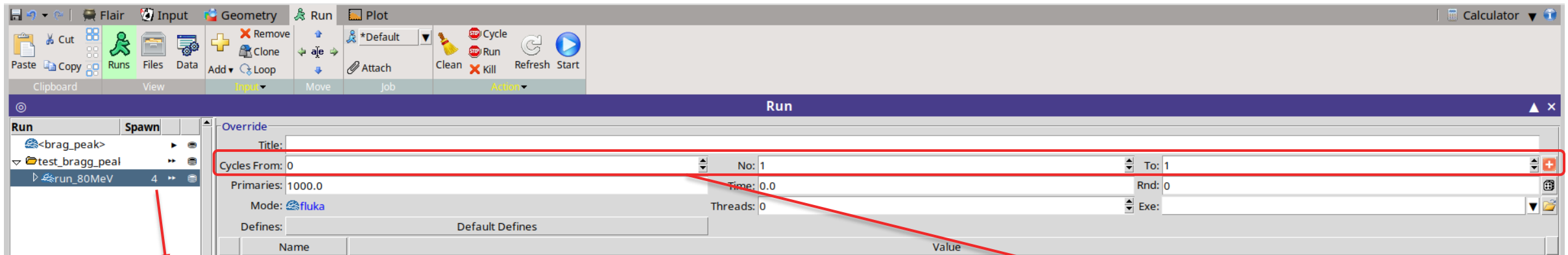
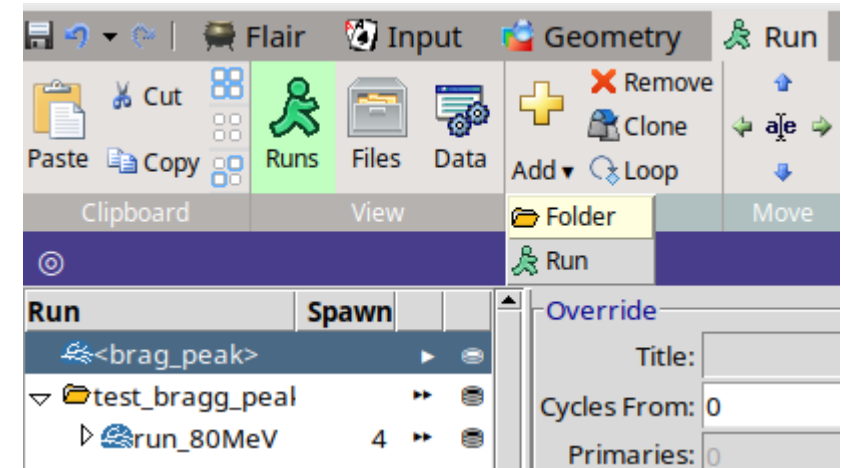

Spawn: independent simulations (in parallel)

Cycles: sequence of simulations

1. Bragg peak simulation: process

- After pressing run, the simulation hopefully finishes smoothly. You have now to process the data

The screenshot shows the Data Flair software interface. A blue callout box with the text "Just click on *Process*" points to the "Process" button in the top toolbar. A green notification box titled "Data Merging" displays "Files created: test_bragg_peak/run_80MeV_21.bnn". The "Run" window is open, showing a table of detectors and a "Files" table. A red arrow points from the "Merge output data page" tooltip to the "Files" table. A blue callout box at the bottom right states "In *Data Flair* automatically picks up your scorings".

Run	Type	Output	Name/Unit
test_bragg_peak/run_80MeV	usrbin	test_bragg_peak/run_80MeV_21.bnn	21

File	Type	Size	Date
test_bragg_peak/run_80MeV_01001_fort.21	21	638	2026.05.02 15:41:43
test_bragg_peak/run_80MeV_02001_fort.21	21	638	2026.05.02 15:41:43
test_bragg_peak/run_80MeV_03001_fort.21	21	638	
test_bragg_peak/run_80MeV_04001_fort.21	21	638	

1. Bragg peak simulation: plot

- With the final *.bnn binary data, you want to plot the longitudinal profile
- The Oz wizard can help us (remember to finalize his guessing)

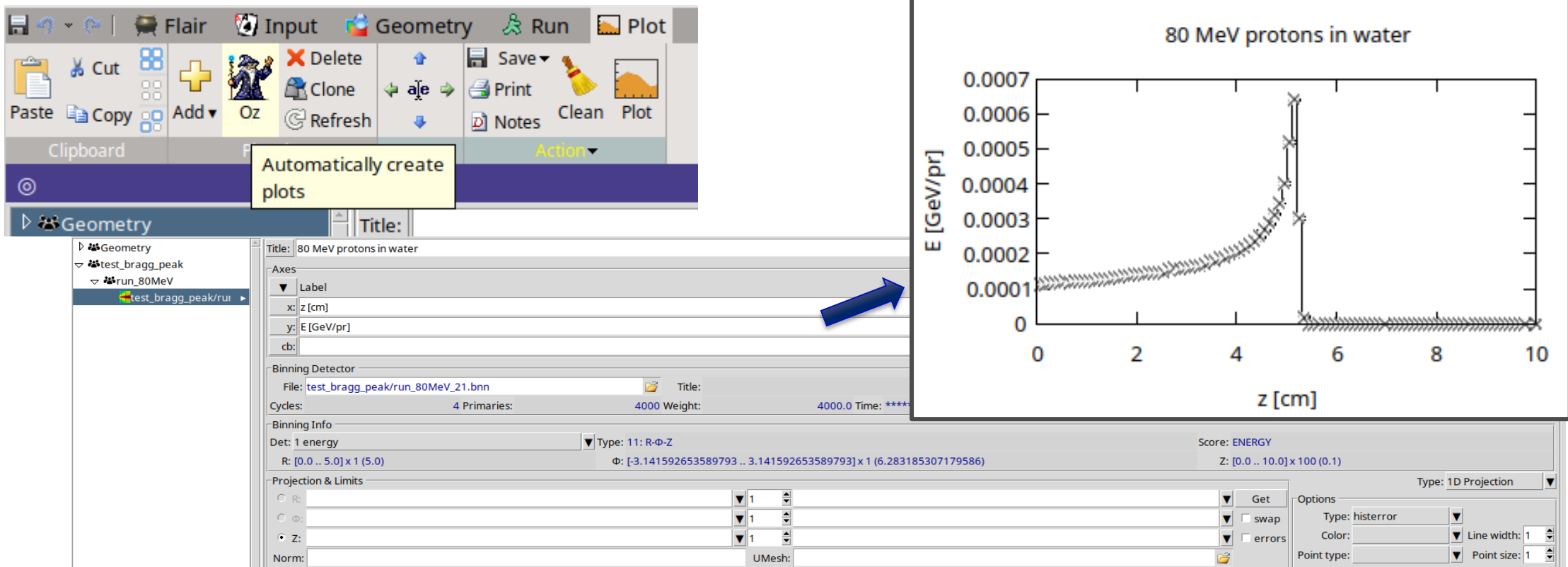

1. Bragg peak simulation: plot

- It is also possible to superimpose the USRBIN results to the geometry viewer

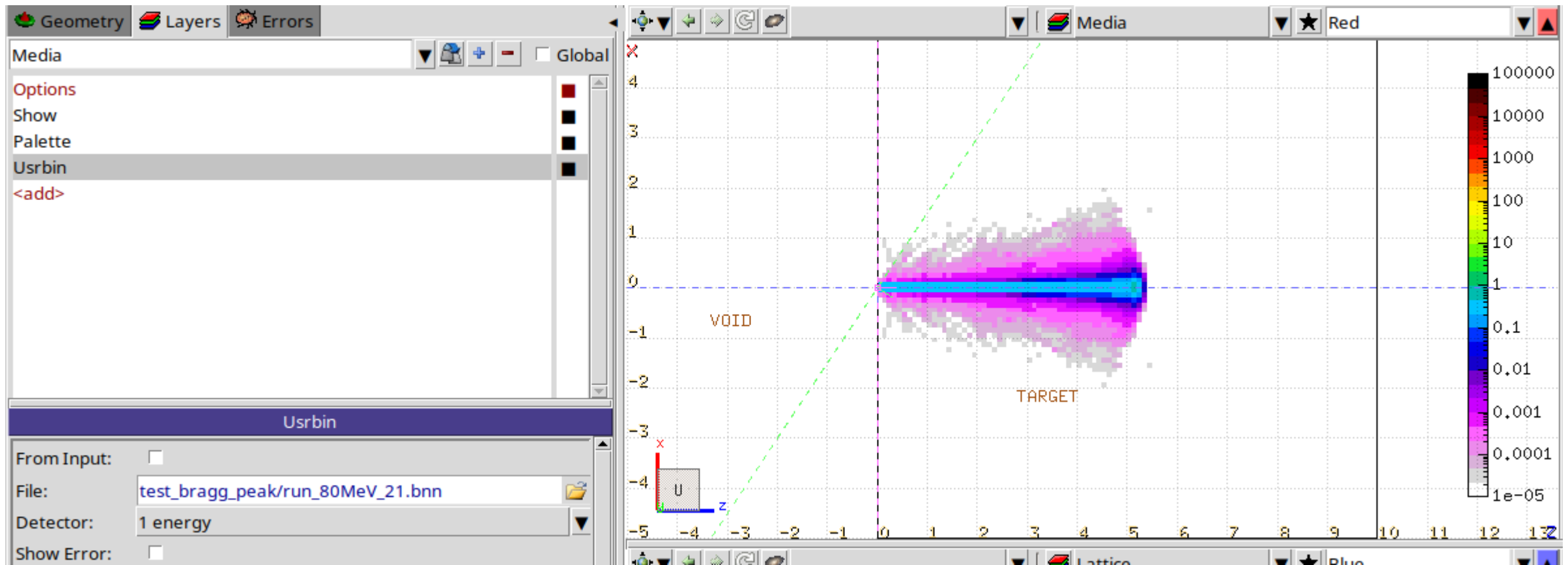

1. Bragg peak simulation: some homework

- We scored and plotted the Bragg peak by proton in water. Some interesting topics can be also checked:
 - Compare the **proton range** against the [pstar](#) reference
 - Check how it moves with **proton energy/target material**
 - Start with **realistic beam sizes/divergences**
 - Think of a way of generating a **SOBP** (Spread Out Bragg Peak) if you want to distribute the dose in a certain volume



2. Other particles/energies

2. Other particles/energies

- In this second part of simulation, we are going to use **high energy protons and electrons**
- Change the geometry to a **6 m long Carbon target** (we can imagine this as being a beam dump)

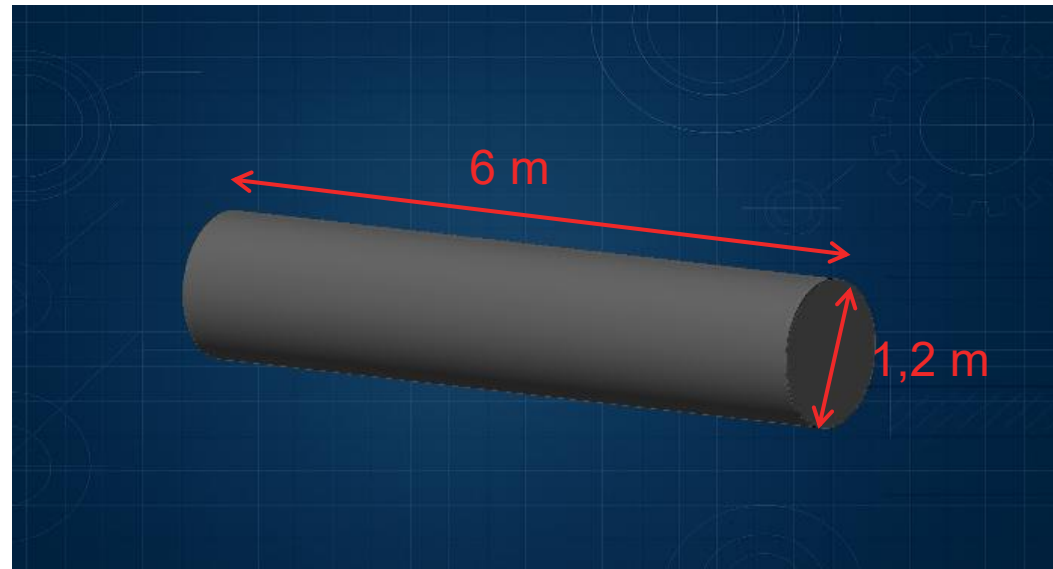

2. Other particles/energies: preprocessor directives

- So far, all information were hardcoded. We want more flexibility to run a set of simulations:
 - **If/else** statement to select protons or electrons
 - **Energy variable** to scan across

2. Other particles/energies: preprocessor directives

- So far, all information were hardcoded. We want more flexibility to run a set of simulations:
 - **If/else** statement to select protons or electrons
 - **Energy variable** to scan across

```
#define PROTON :
#define ENERGY :1
Set the defaults for precision simulations
DEFAULTS : PRECISIO
#if PROTON
  Define the beam characteristics
  BEAM Beam: Energy E: ==ENERGY Part: PROTON
    Δp: Flat Δp: Δφ: Flat Δφ:
    Shape(X): Rectangular Δx: Shape(Y): Rectangular Δy:
#else
  Define the beam characteristics
  BEAM Beam: Function E: ==ENERGY Part: ELECTRON
    Δp: Flat Δp: Δφ: Flat Δφ:
    Shape(X): Rectangular Δx: Shape(Y): Rectangular Δy:
#endif
```

PROTON: used to select which card to use

ENERGY: variable used inside card's WHATs

2. Other particles/energies: energy cuts

- To run the simulation in less time, let's increase the **energy thresholds**. Set them at 1 MeV for $e^{+/-}$ and 300 keV for photons

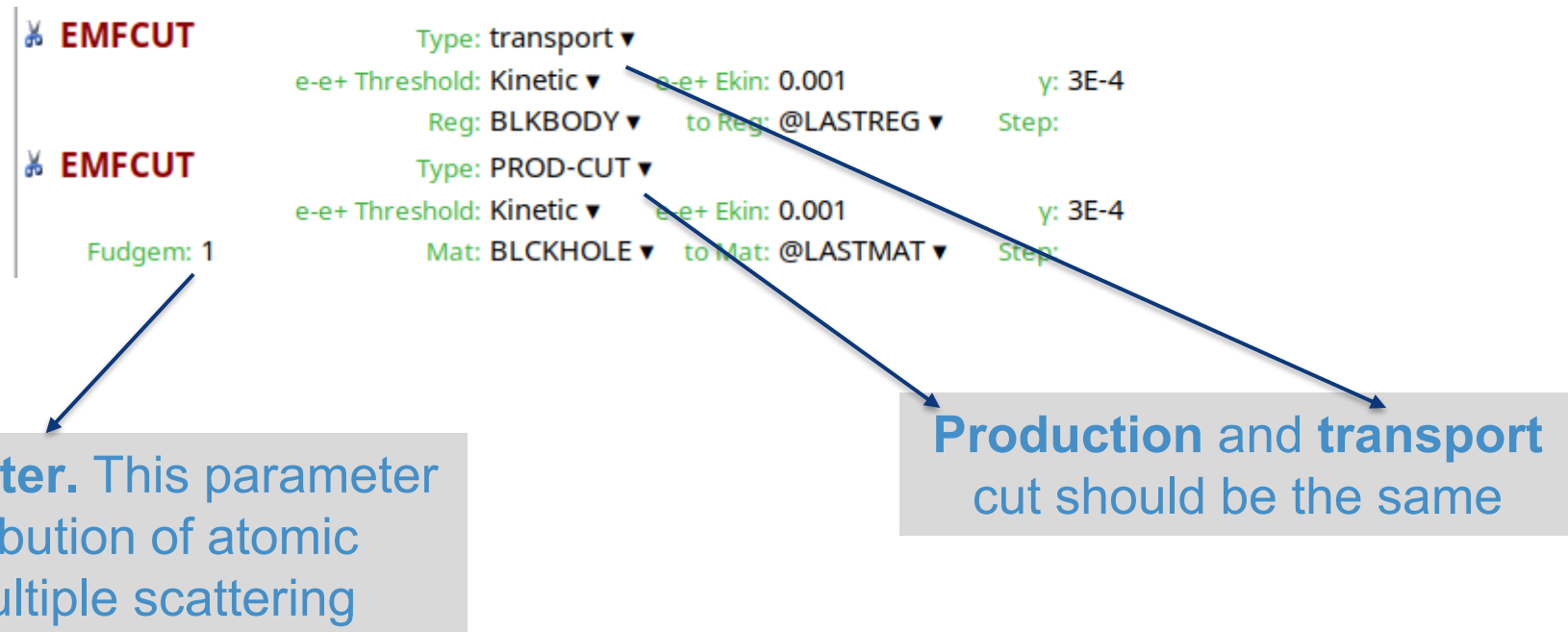

2. Other particles/energies: high energy p & e^{+/-}

- Create a folder for protons and one for electrons. Ran simulations with energies ranging from **100 MeV** to **10 GeV**
- How varies the **CPU time**?

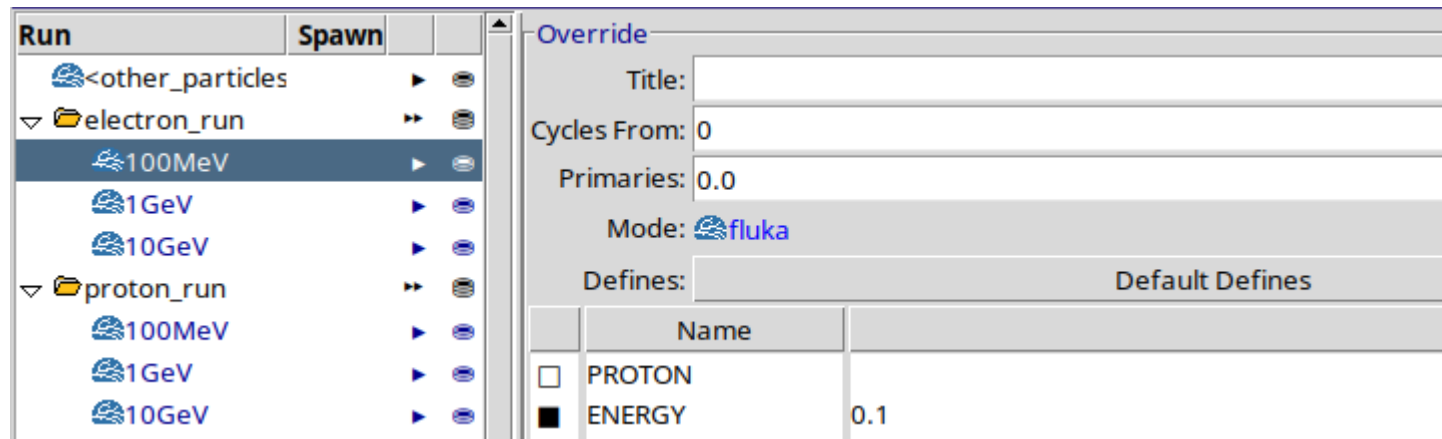

2. Other particles/energies: high energy p & e^{+/-}

- Plot the results. How the **energy distribution** looks like?
- Why the Bragg peak disappears with high energy protons?

2. Other particles/energies: high energy p & e^{+/-}

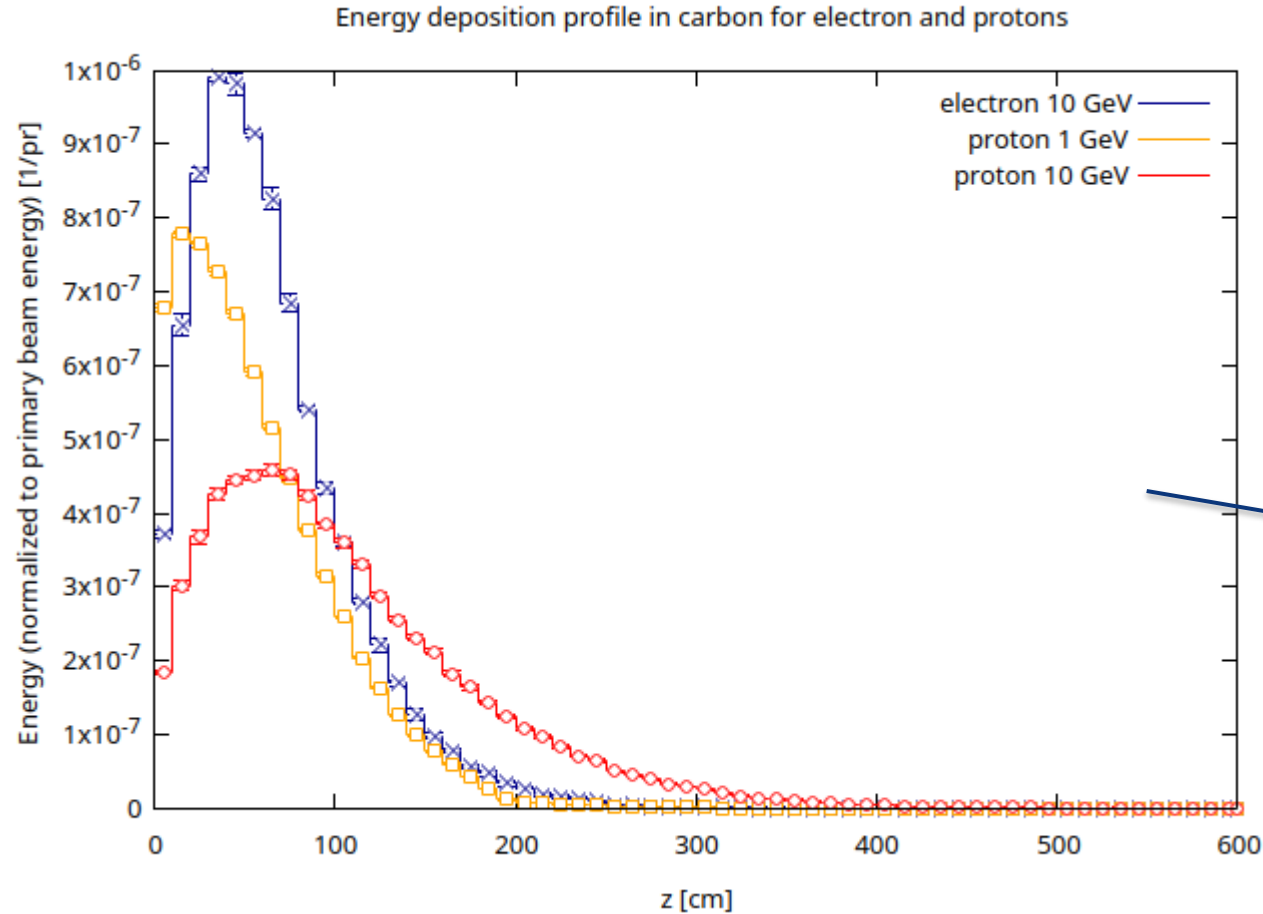

- Is it more difficult to **shield** protons or electrons?
- How to explain the tail in the distribution?

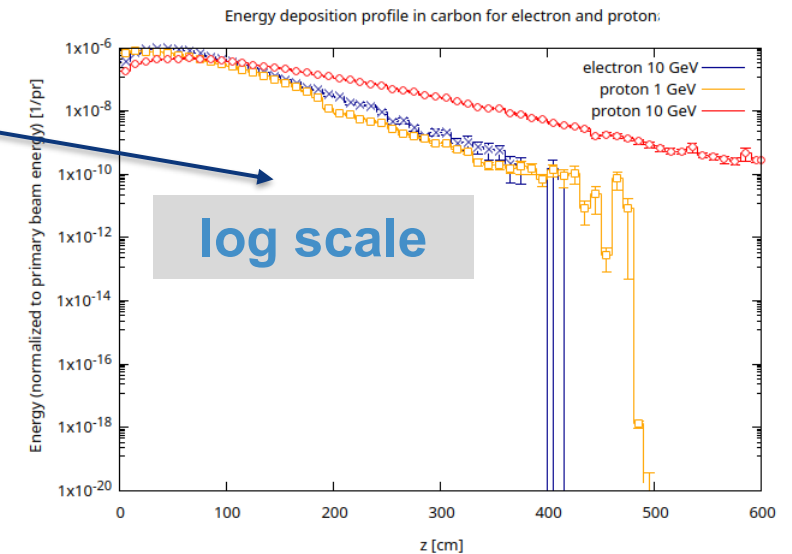

2. Other particles/energies: observe particle fluences

- Let's consider the 10 GeV proton case.
- With USRBIN scorings check the particle fluence in the volume (e^{\pm} , neutrons, protons, pions and muons)
- Are we leaking neutrons? Check the spectrum exiting the dump via USRBDX

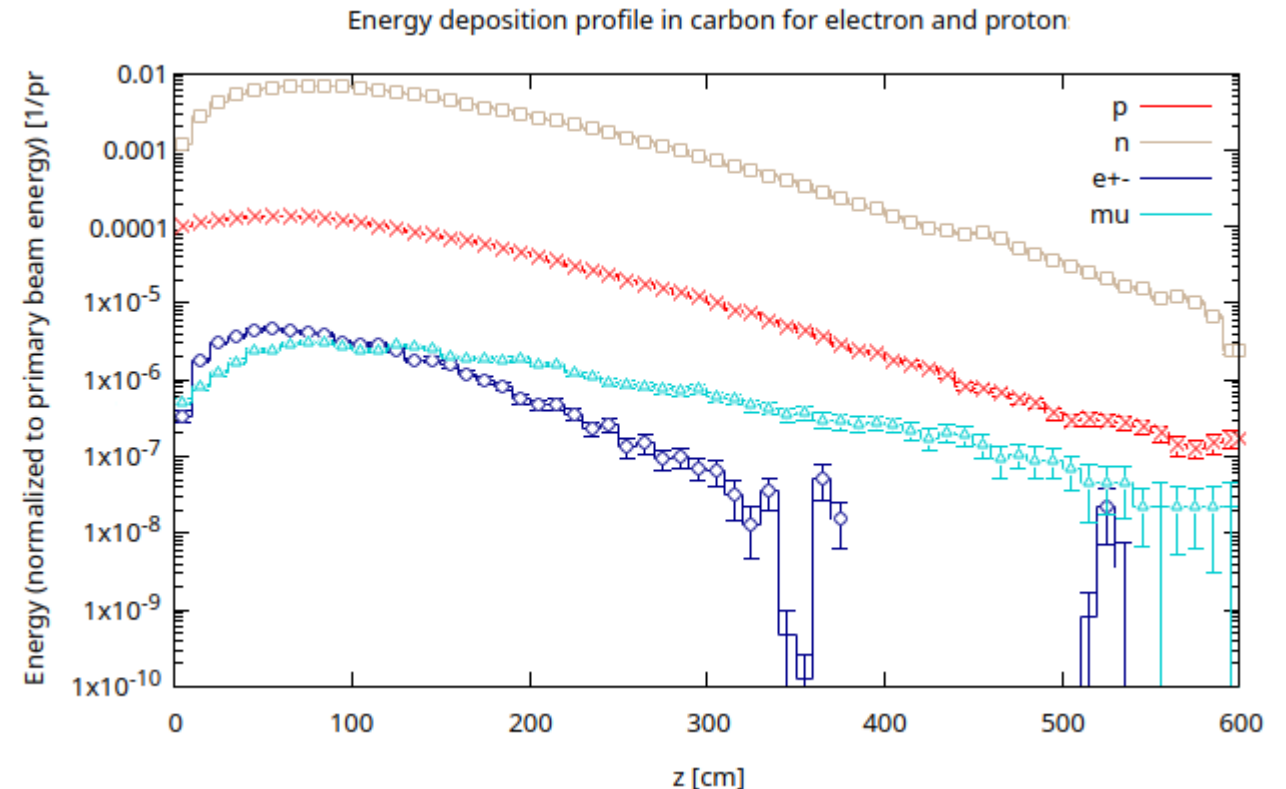
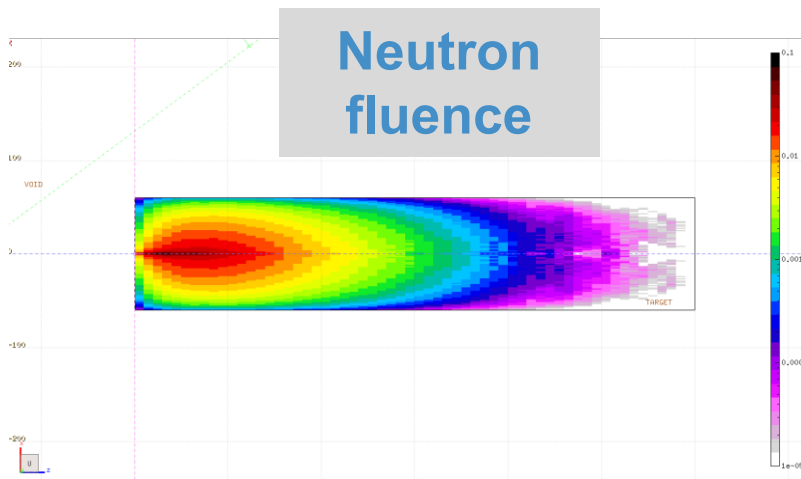

2. Other particles/energies: observe particle fluences

- Let's consider the 10 GeV proton case.
- With USRBIN scorings check the particle fluence in the volume ($e^{+/-}$, neutrons, protons, pions and muons)
- Are we leaking neutrons? Check the spectrum exiting the dump via USRBDX

Can you explain the spectrum shape?

Leaking neutrons energy spectrum

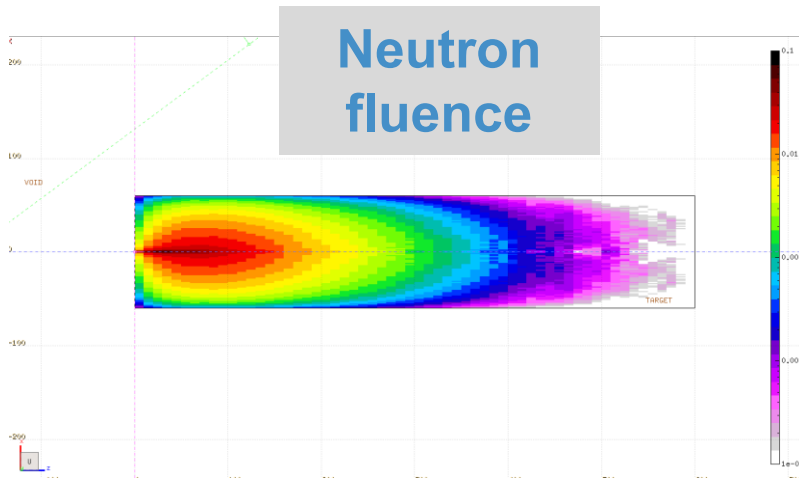
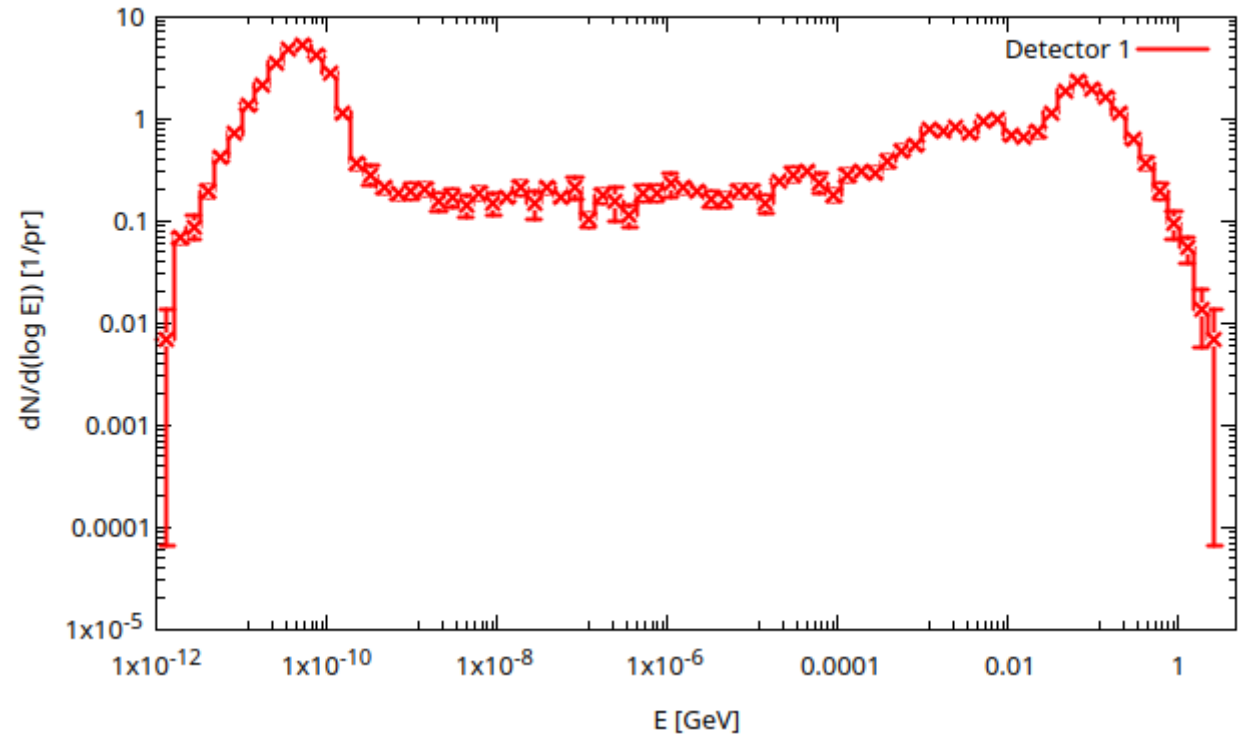





3. Activation

3. Activation: why is important

- Induced radioactivity is an integral part of many **Radiation Protection** assessments
- Total and/or specific (mass) activity for all the various radionuclides
- Basic Scoring options in FLUKA:
 - **RESNUCLEI** - Region based: gives access to full inventory information (radionuclide specific incl. isomeric states)
 - Other options: FLUKA Advanced course

3. Activation: how to enable it

- To appropriately score the residual nuclei, we need to enable:
 - The **coalescence** treatment
 - The **evaporation** of heavy fragments
- Please remember to run with ***flukadpm*** or to link **RQMD** and **DPMJET** if producing a custom executable

 RESNUCLEI	Type: All ▼	Unit: 23 BIN ▼	Name: res
Max Z:	Max M:	Reg: TARGET ▼	Vol: 1
 PHYSICS	Type: COALESCE ▼	Activate: On ▼	
 PHYSICS	Type: EVAPORAT ▼	Model: New Evap with heavy frag ▼	
	Zmax: 0	Amax: 0	

3. Activation: results with our geometry

- With pure carbon the residual activation is minimal
- We see elements up to Z and A of the target material
- Some reactions:
 - Fragmentation
 - Fission (maybe not with carbon...)
 - Capture
- What would happen with a lead target? Let's simulate it

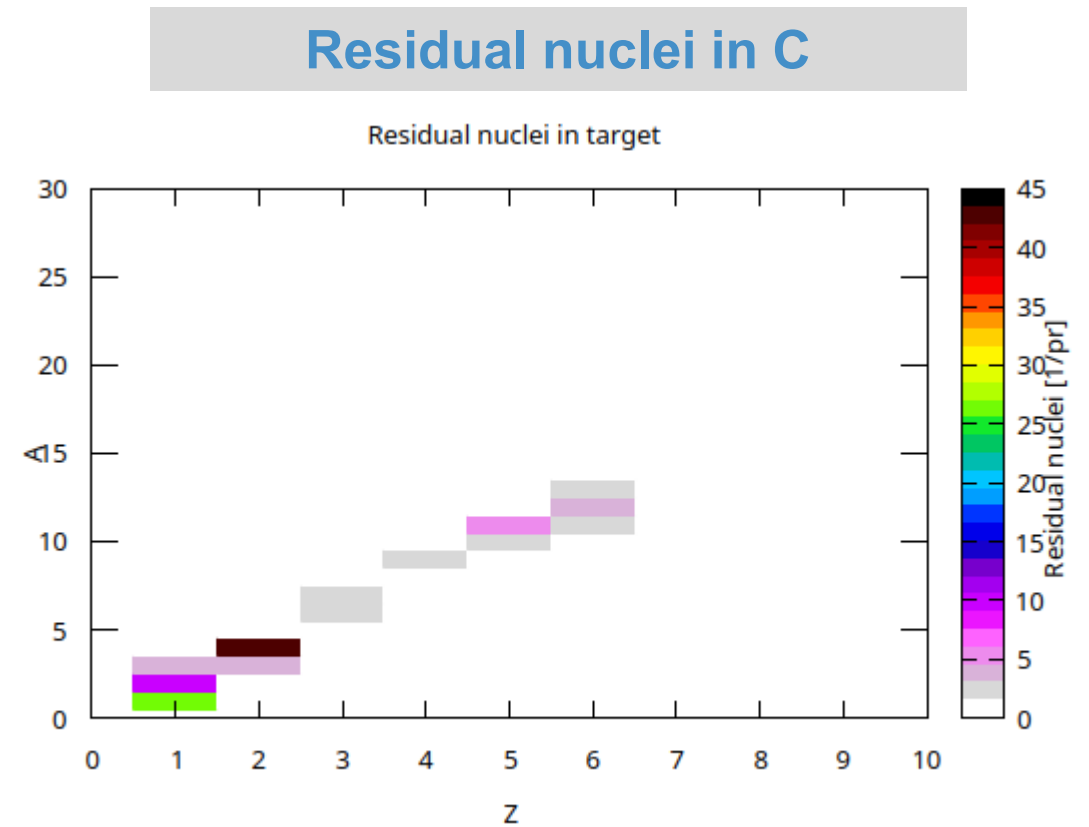

3. Activation: results with our geometry

- High energy particles + heavy target → whole periodic table!

Residual nuclei in C

Residual nuclei in target

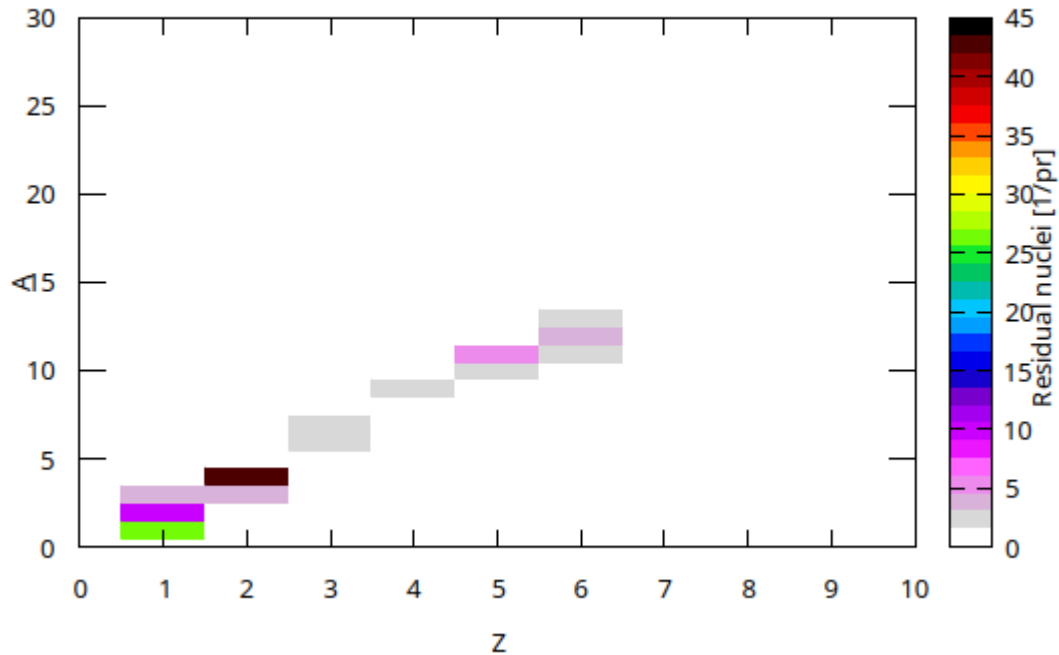

Residual nuclei in Pb

Residual nuclei in target

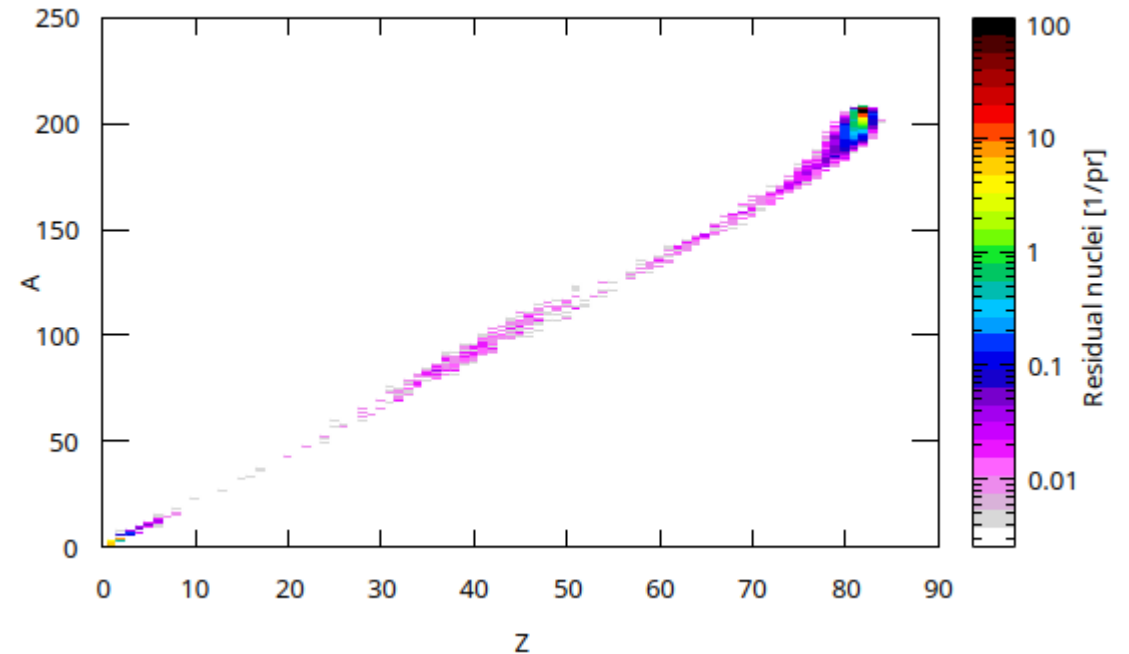

Conclusions

- Today we barely scratched the surface of the FLUKA capabilities
- FLUKA is incredibly powerful, and the standard de-facto for many applications (**industrial, medical and research**)
- With a *personal license* you can continue to expand on the simple example I brought you today. **It could be part of your job tomorrow!**
- If you want to dig deeper, many channels are open:
 - **FLUKA forum**, where most Q&A takes place
 - **FLUKA courses**
 - ...or just send me an email!

Thank you for your attention!

