

# Excited-State Lifetime Measurements in Neutron-Rich Ca, Ar Isotopes

Beau Greaves

GAMMA Collaboration Meeting  
Sezione INFN di Milano  
09/04/2026



# Ca isotopes: a very magic set of nuclei

48Ti	49Ti	50Ti	51Ti	52Ti	53Ti	54Ti	55Ti	56Ti
47Sc	48Sc	49Sc	50Sc	51Sc	52Sc	53Sc	54Sc	55Sc
46Ca	47Ca	48Ca	49Ca	50Ca	51Ca	52Ca	53Ca	54Ca
45K	46K	47K	48K	49K	50K	51K	52K	53K
44Ar	45Ar	46Ar	47Ar	48Ar	49Ar	50Ar	51Ar	52Ar
43Cl	44Cl	45Cl	46Cl	47Cl	48Cl	49Cl	50Cl	51Cl
42S	43S	44S	45S	46S	47S	48S	49S	
41P	42P	43P	44P	45P	46P			

Z = 20

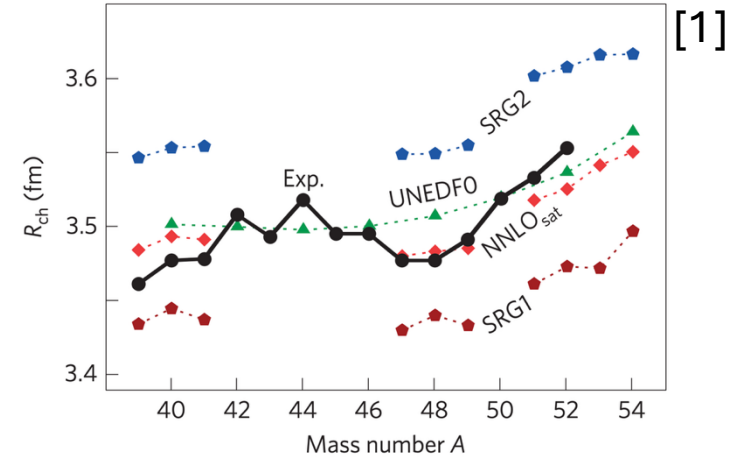
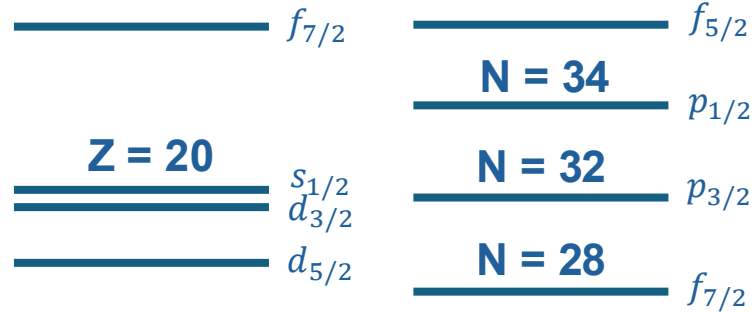

N = 28

- $E(2^+) = 700 - 800$  keV
- $E(2^+) = 1000 - 1500$  keV
- $E(2^+) > 2500$  keV

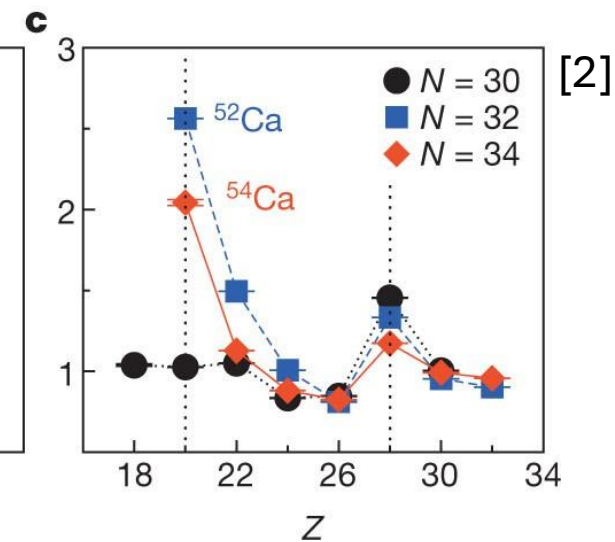
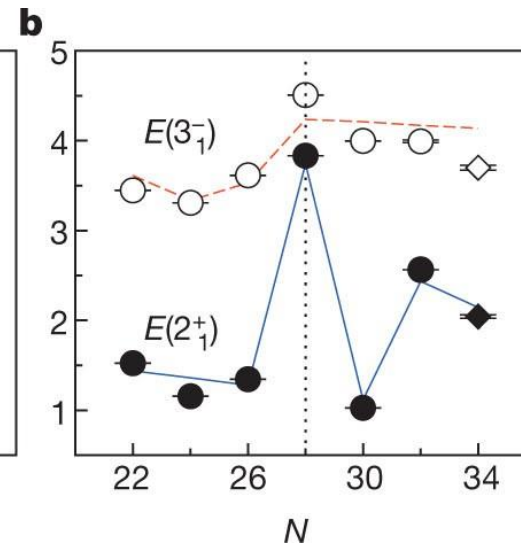
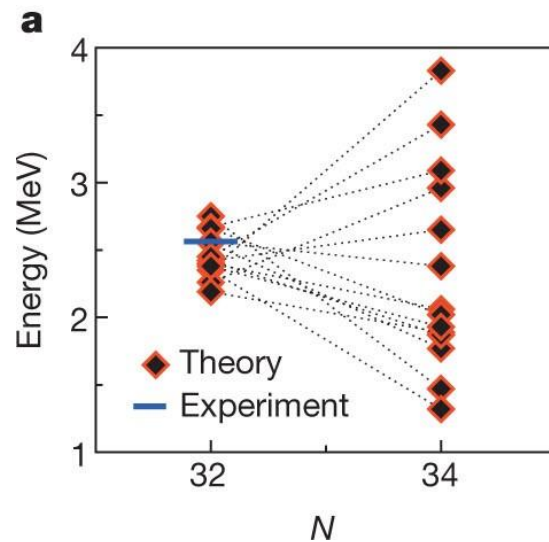

[1] R.F. Garcia Ruiz et al., Nat. Phys. **12**, 594 (2016)  
 [2] D. Steppenbeck et al., Nature **502**, 207–210 (2013)

# E2, M1 strengths to probe shell structure

Black: KB3G

Red: KB3G modified to reproduce N=34 closure, 3-body interaction from L. Coraggio et al. (similar results from GXPF1Br)

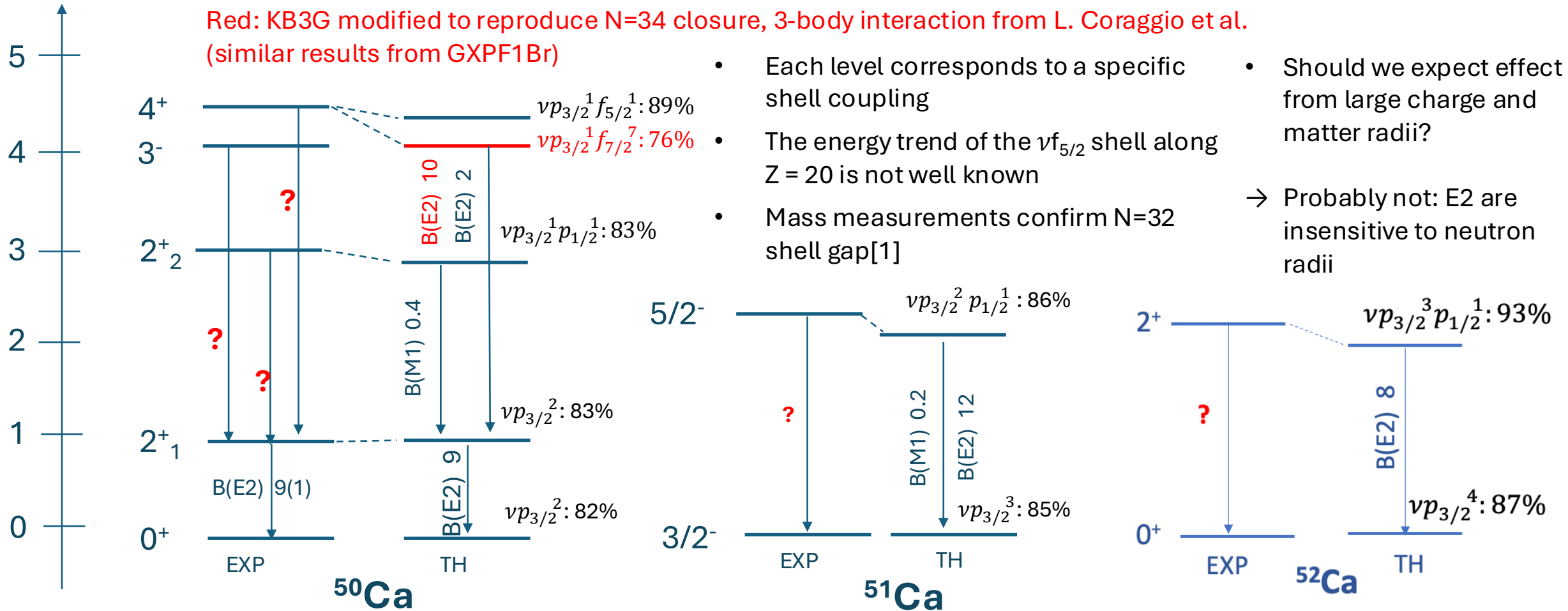

- Each level corresponds to a specific shell coupling
  - The energy trend of the  $\nu f_{5/2}$  shell along  $Z = 20$  is not well known
  - Mass measurements confirm N=32 shell gap[1]
  - Should we expect effect from large charge and matter radii?
- Probably not: E2 are insensitive to neutron radii

[1] A.T. Gallant et al., PRL 109, 032506 (2012)

# 46-48Ar: from sphericity to collectivity

## Evolution of collectivity involving the N=28 core breaking towards 2nd island of inversion in 42Si

- lifetime of the 46Ar 2+ and 4+ state, which is a p-h across N=28: can SDPF-U predict amount of quadrupole deformation?
- lifetime of the 47Ar 7/2- state, which is  $\nu p_{3/2} \otimes \pi 2^+$ : further probe of a suppressed (or not) 2+ E2 in 46Ar
- lifetime of the 48Ar 2+, 4+ states: determination of B(E2)'s

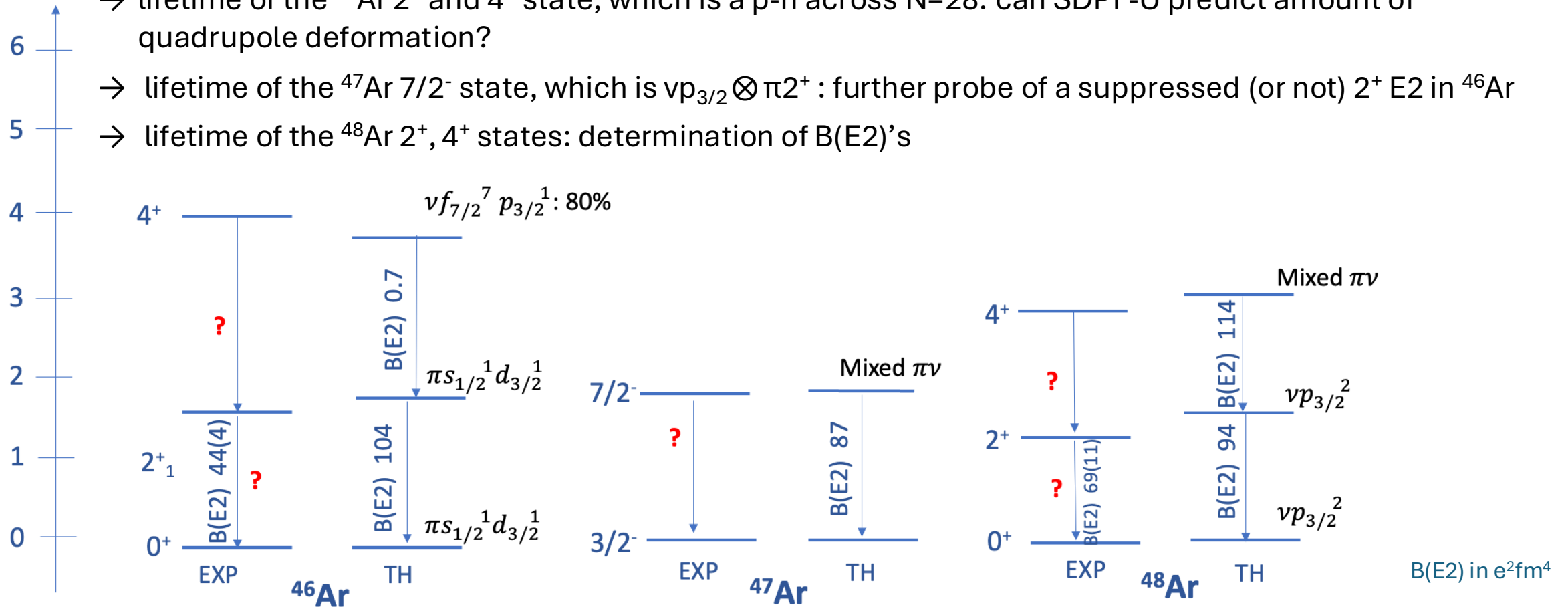

# Experiment 22.81

## AGATA-PRISMA – April 2024

- 305 MeV  $^{48}\text{Ca}$  beam  $\rightarrow$   $^{238}\text{U}$  target + Nb backing
- $\sim$  2 weeks of beamtime, split into 2 components:

### Doppler-Shift Attenuation Method (DSAM)

- 1 mg/cm $^2$   $^{238}\text{U}$  target backed with 5 mg/cm $^2$  Nb
- $\rightarrow$  For states with lifetimes  $\lll$  1 ps

### Recoil-Distance Doppler-Shift (RDDS) Technique

- 1 mg/cm $^2$   $^{238}\text{U}$  target with a 1 mg/cm $^2$  Nb backing
  - 4.9 mg/cm $^2$  Nb degrader spaced 25  $\mu\text{m}$ , 50  $\mu\text{m}$ , and 70  $\mu\text{m}$  using Cologne Compact Plunger
- $\rightarrow$  For states with lifetimes  $\sim$ 10 ps

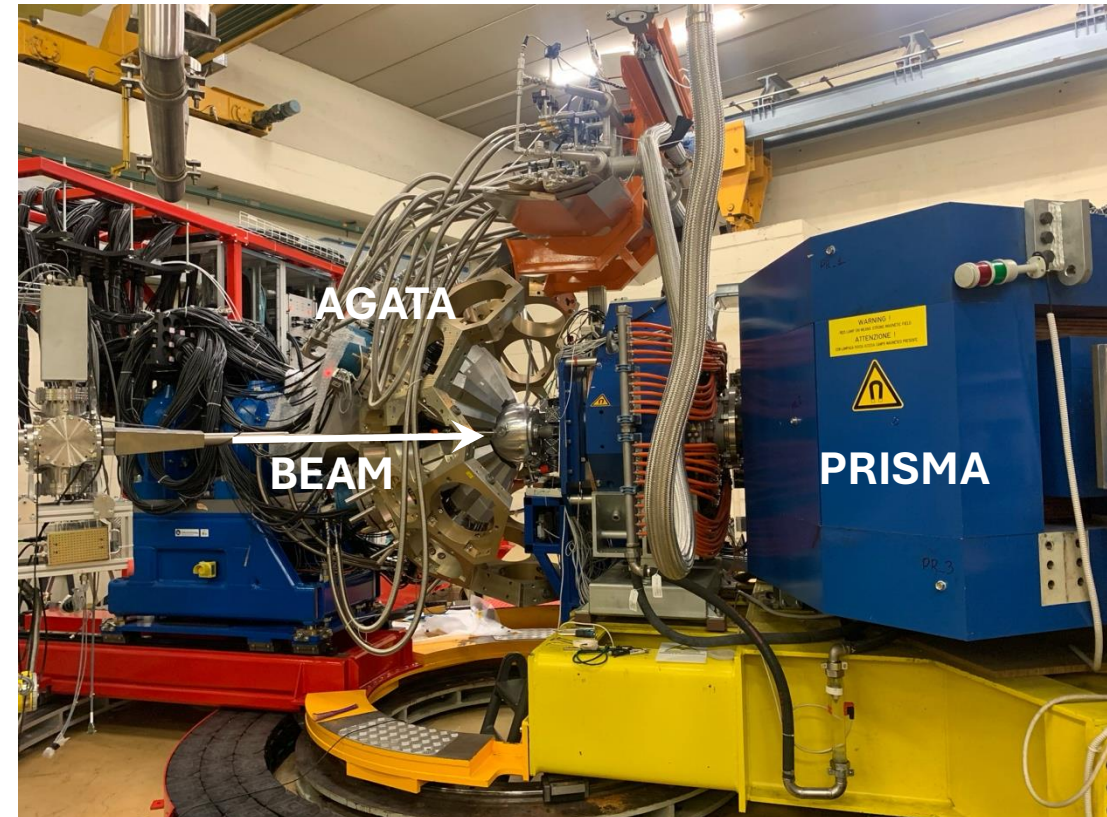

# Experiment 22.81 - DSAM

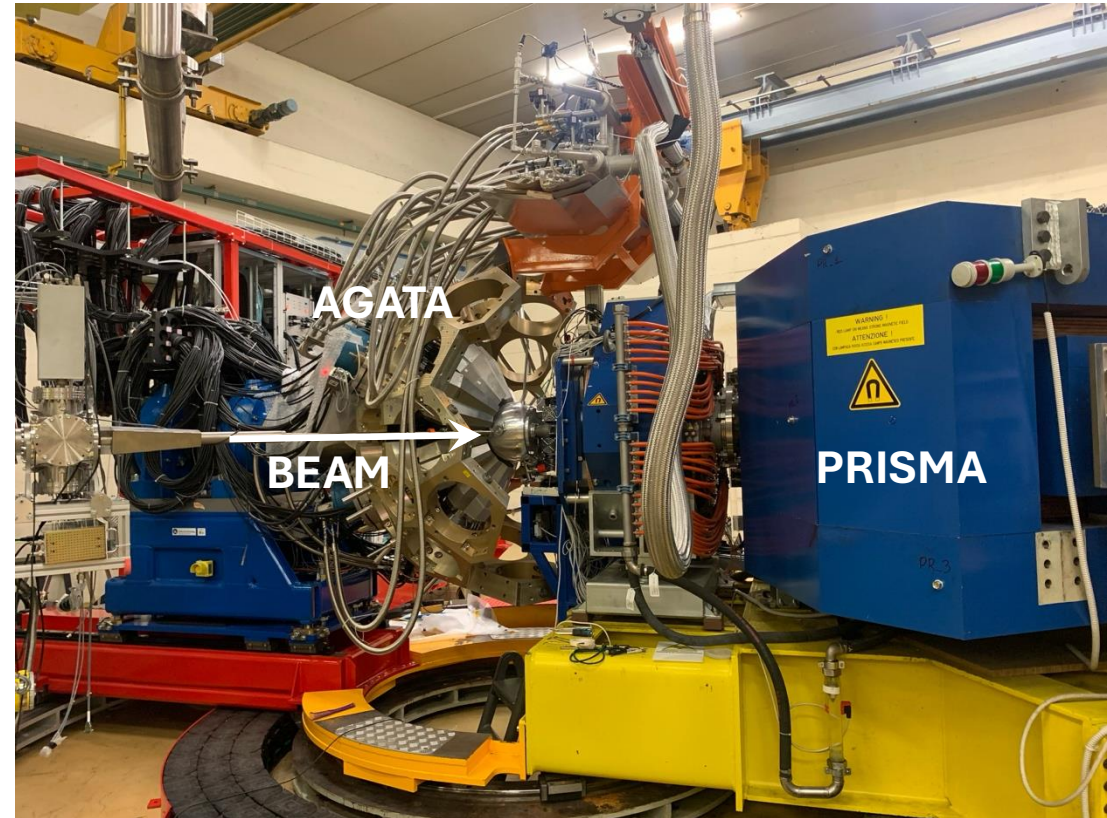
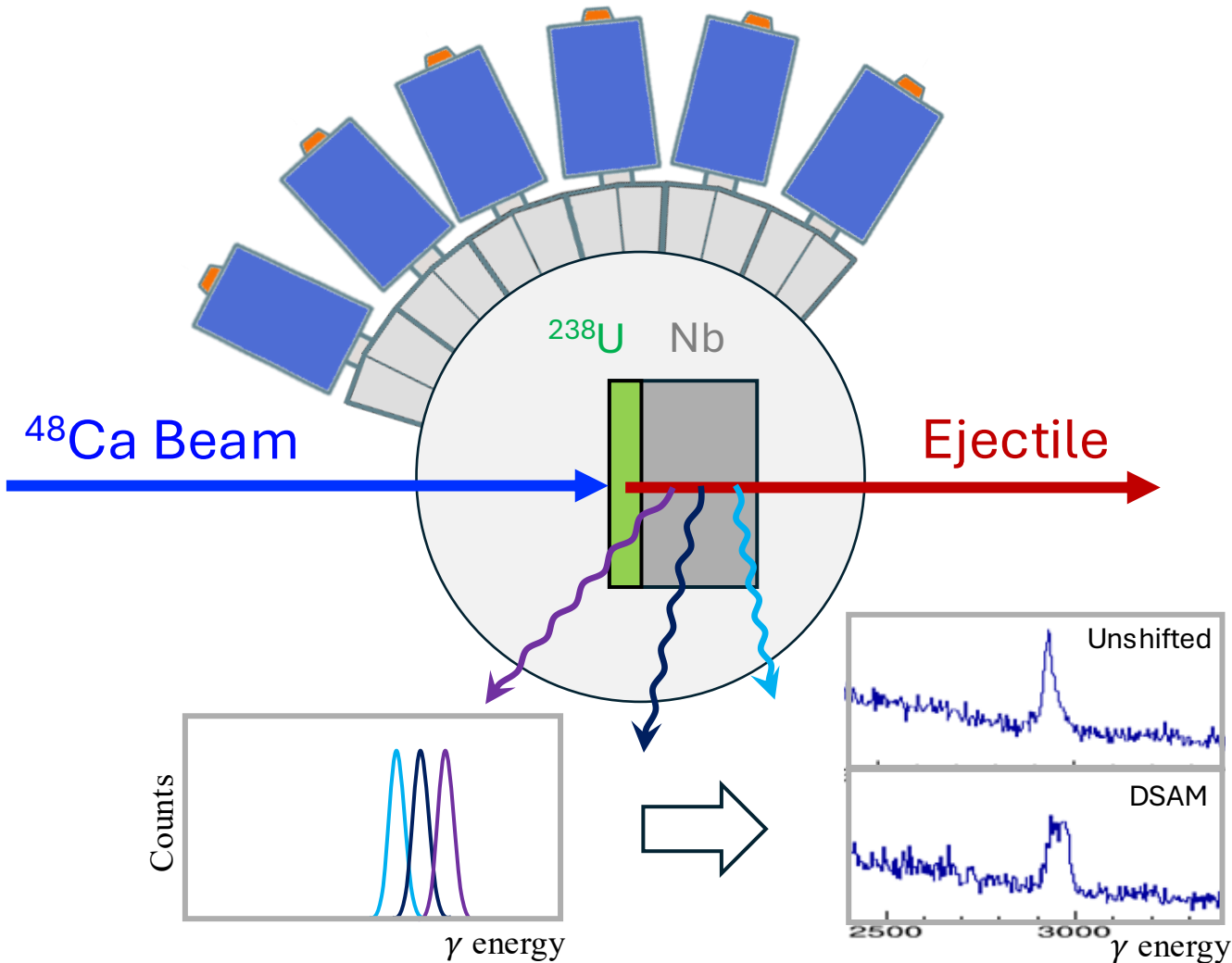

NB: during DSAM, old trigger processor, around 50% dead time

During RDDS, new hardware TP, full capacity

# Experiment 22.81 - RDDS

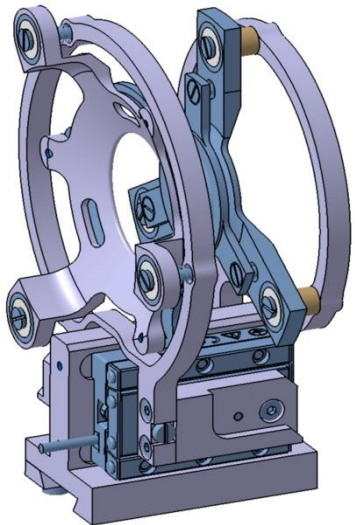
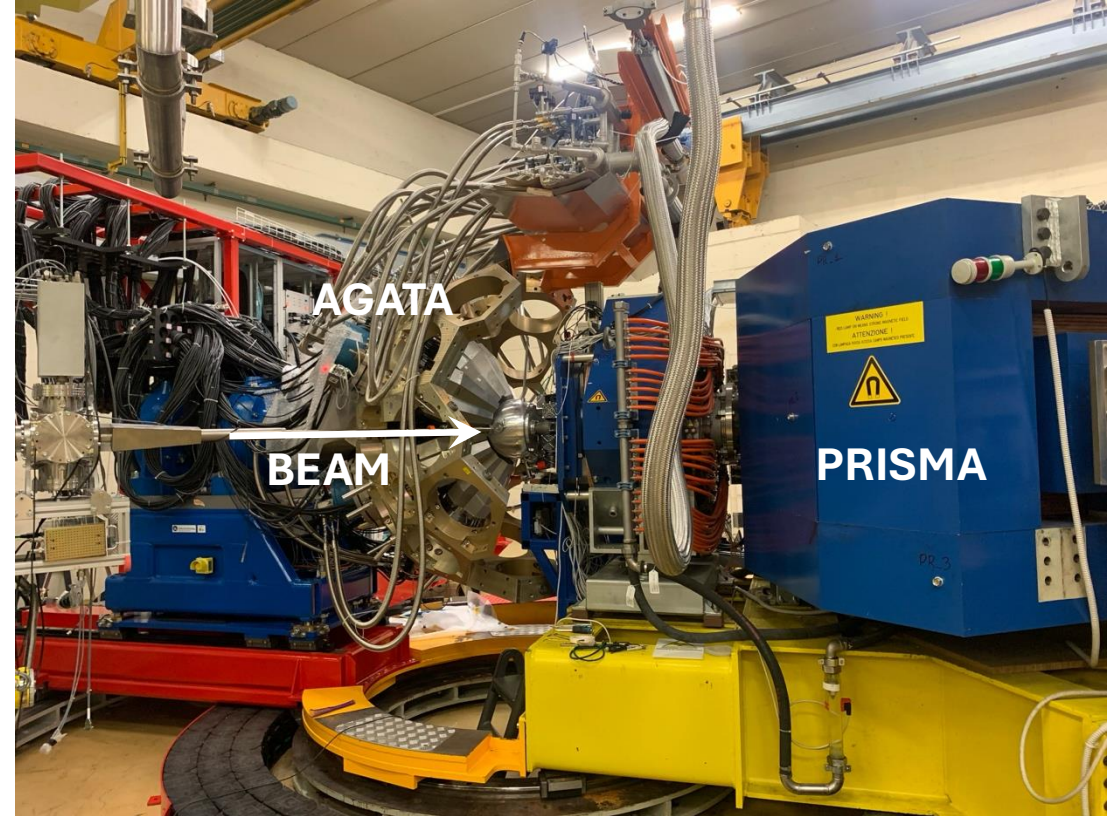
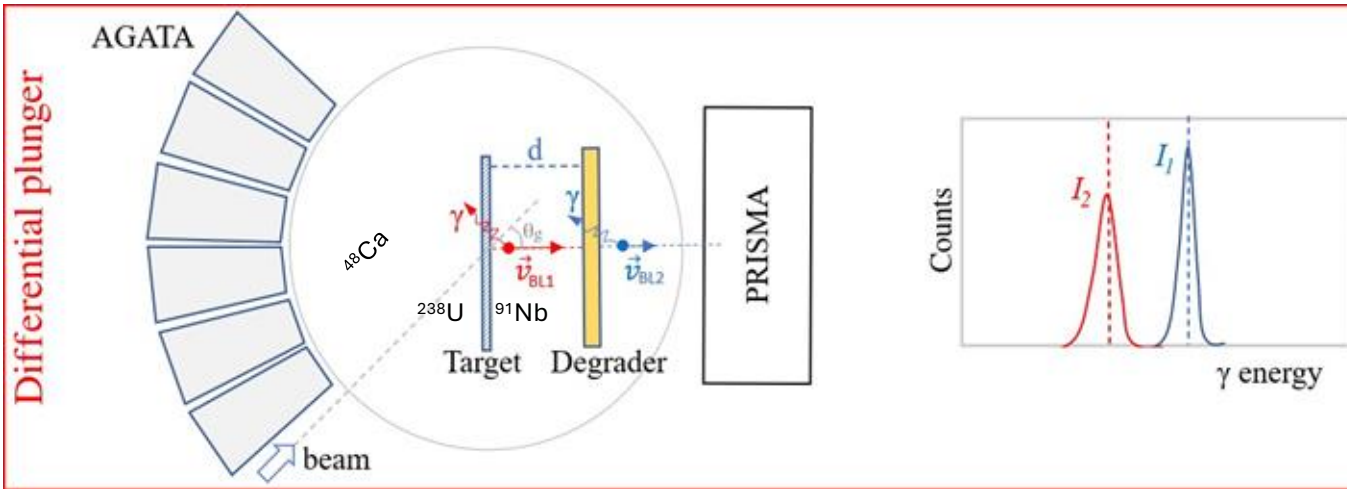

Cologne  
Compact  
Plunger

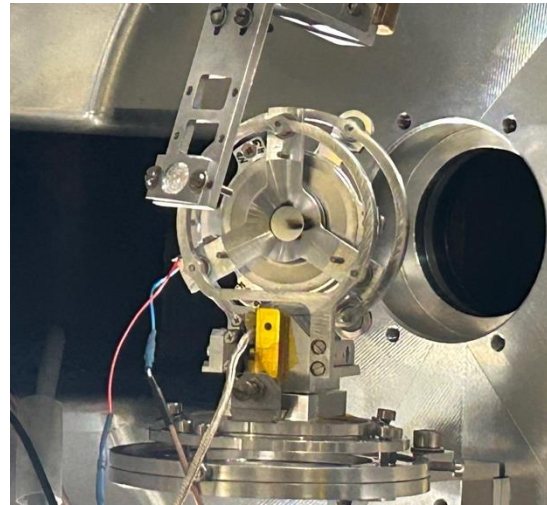

NB: during DSAM, old trigger processor, around 50% dead time  
During RDDS, new hardware TP, full capacity

# PRISMA Analysis

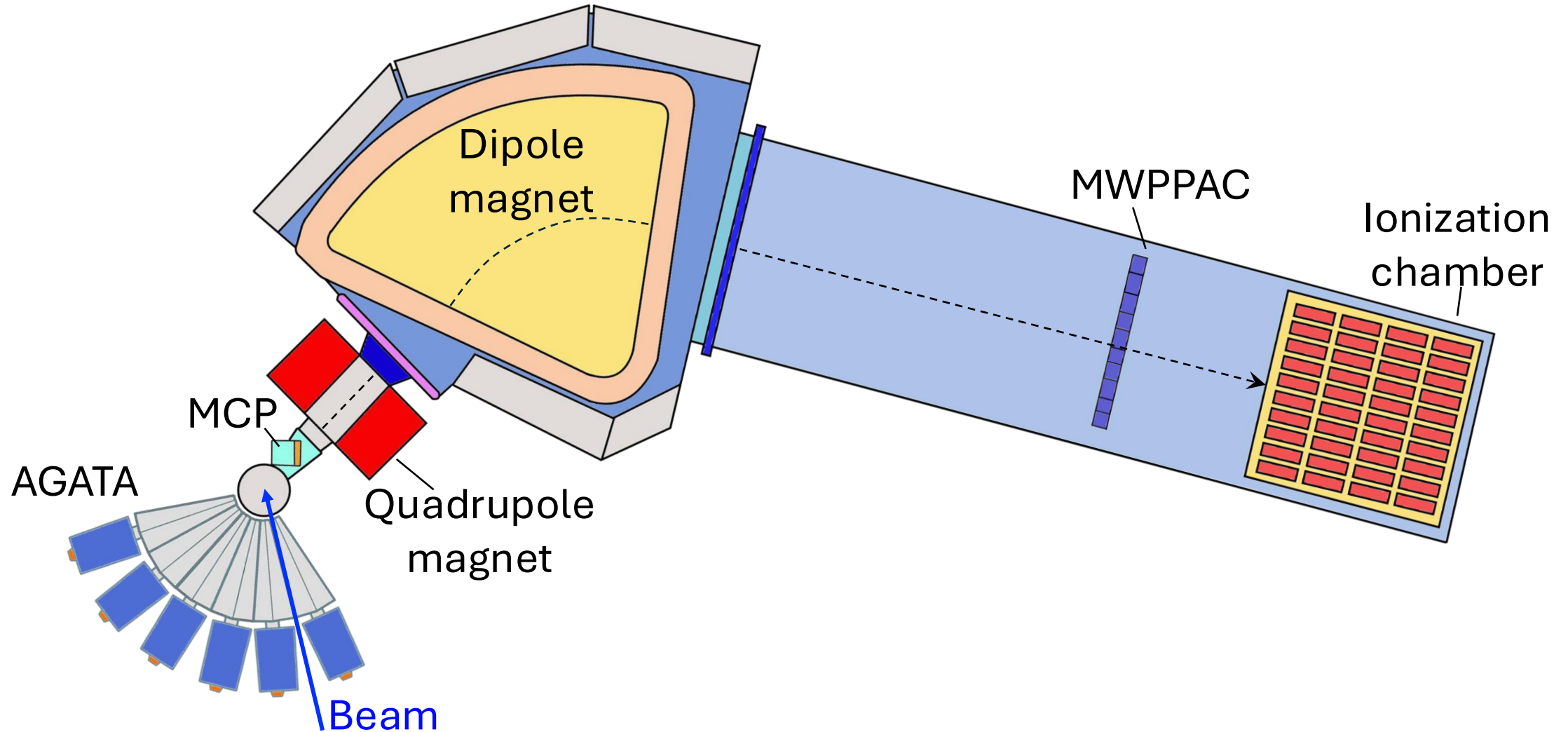

# Micro Channel Plate (MCP)

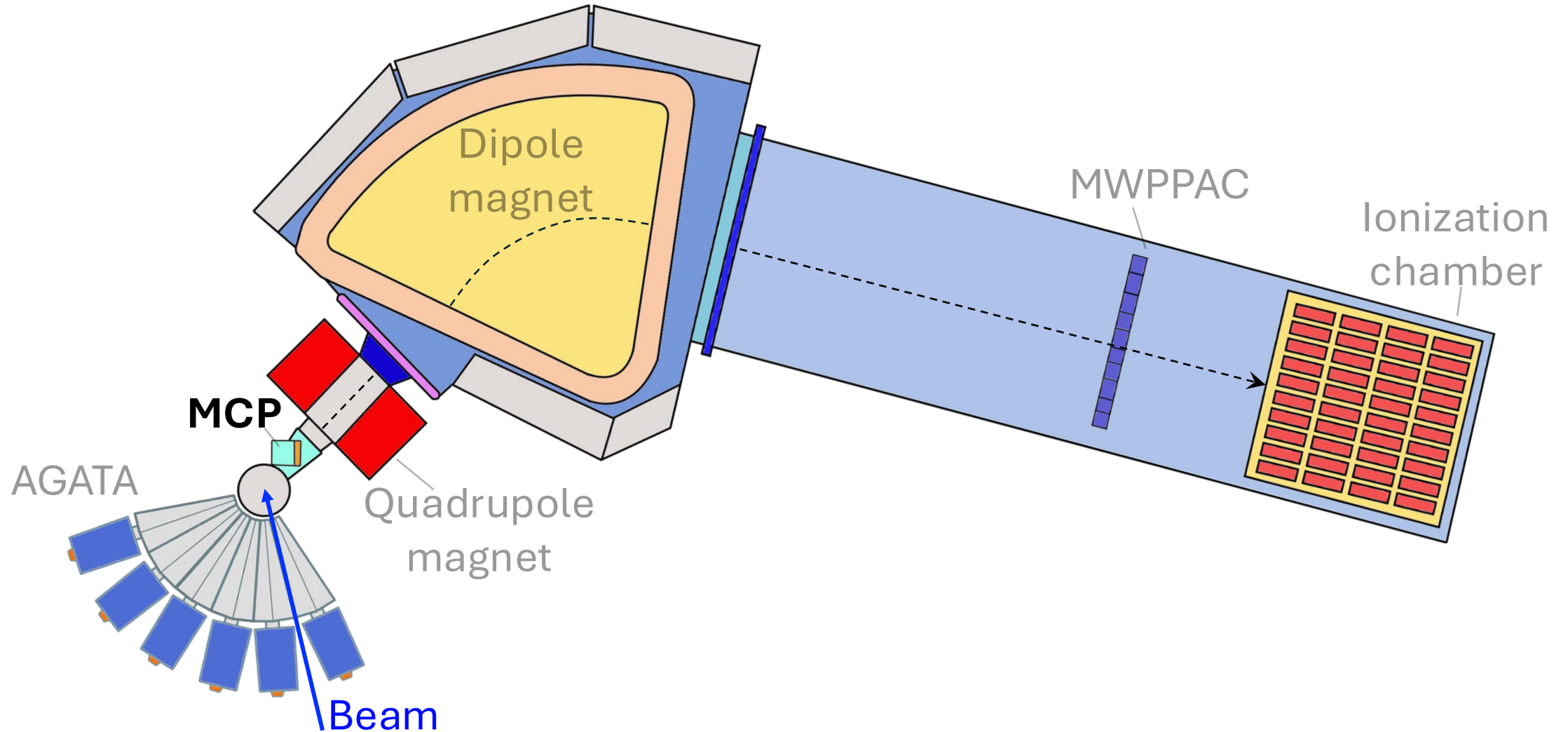

# Micro Channel Plate (MCP)

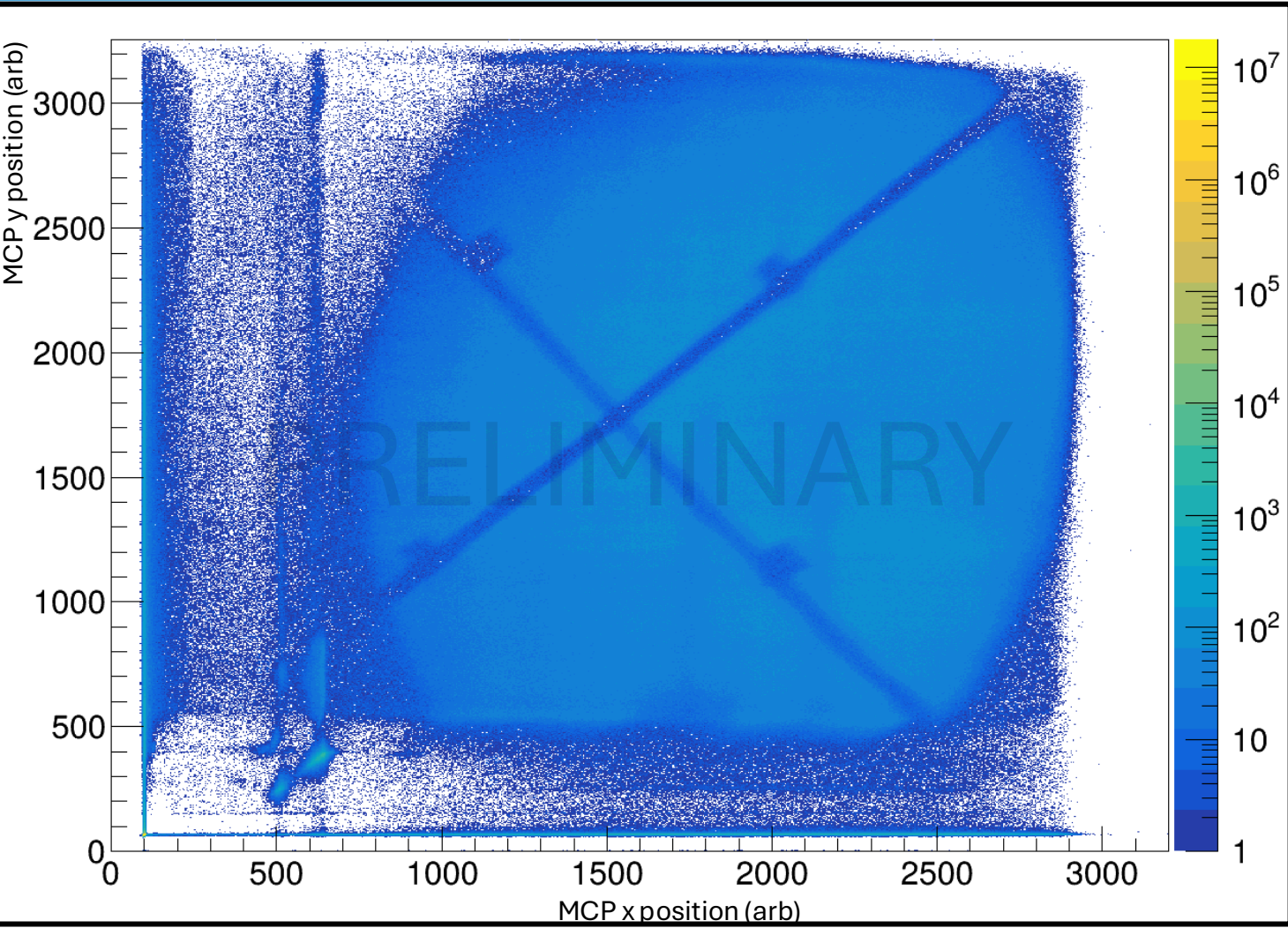
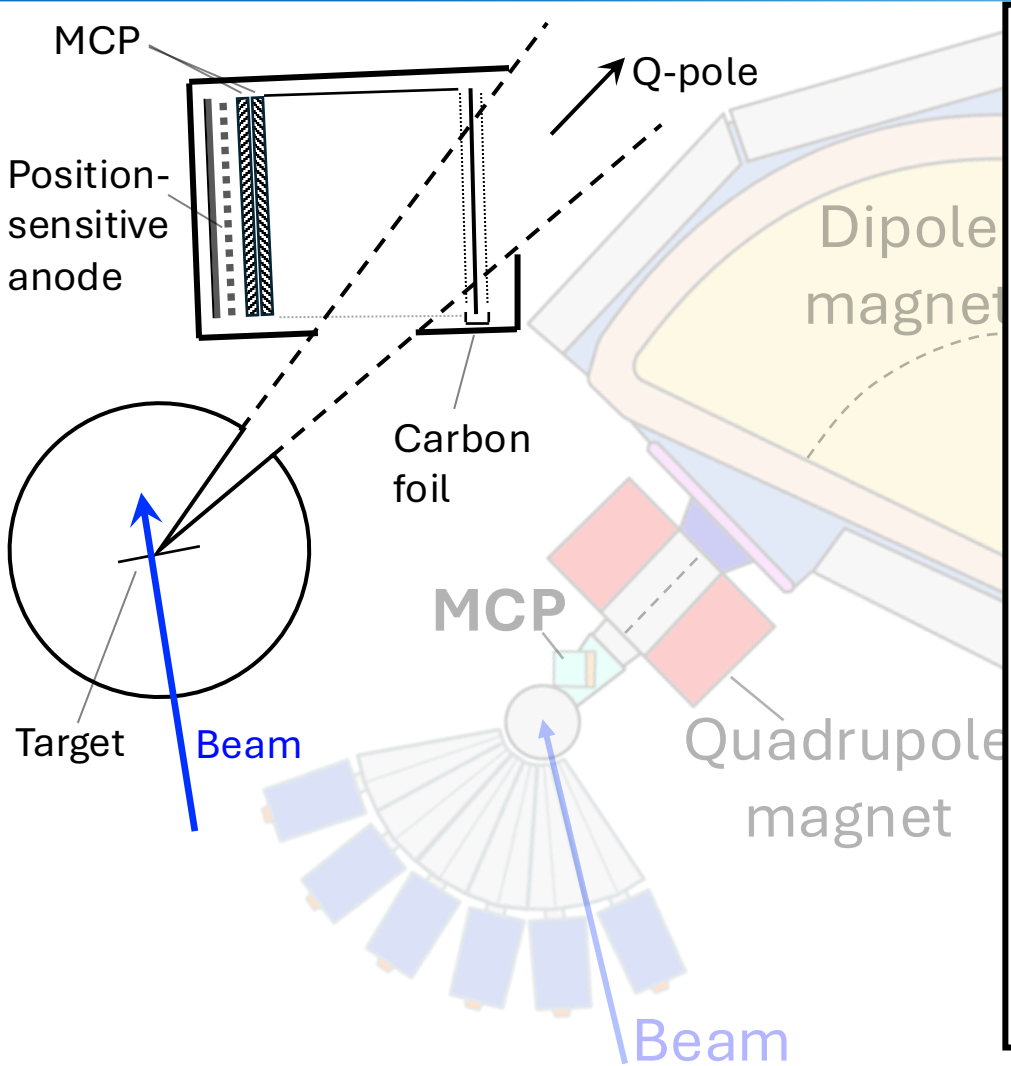

# Micro Channel Plate (MCP)

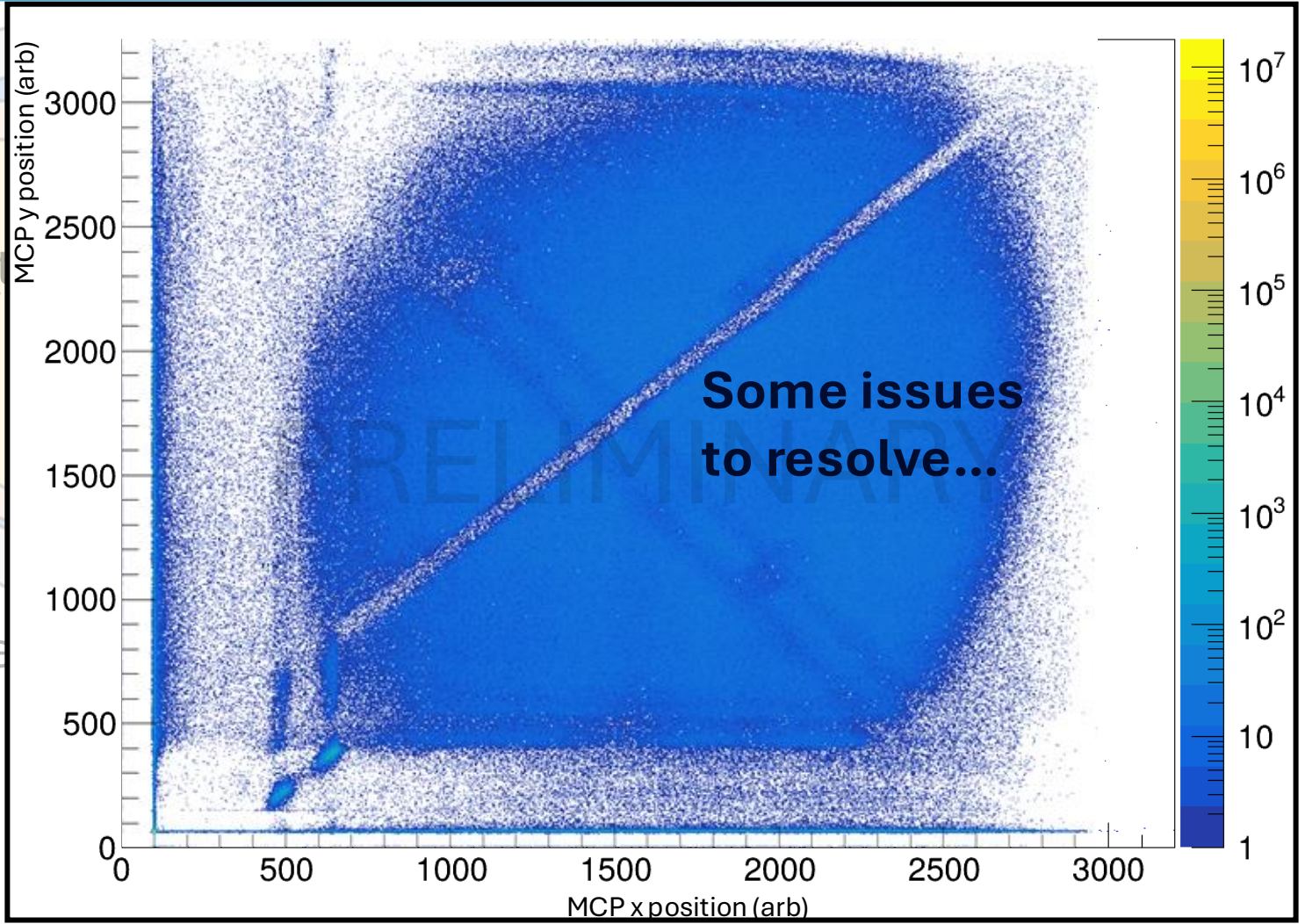
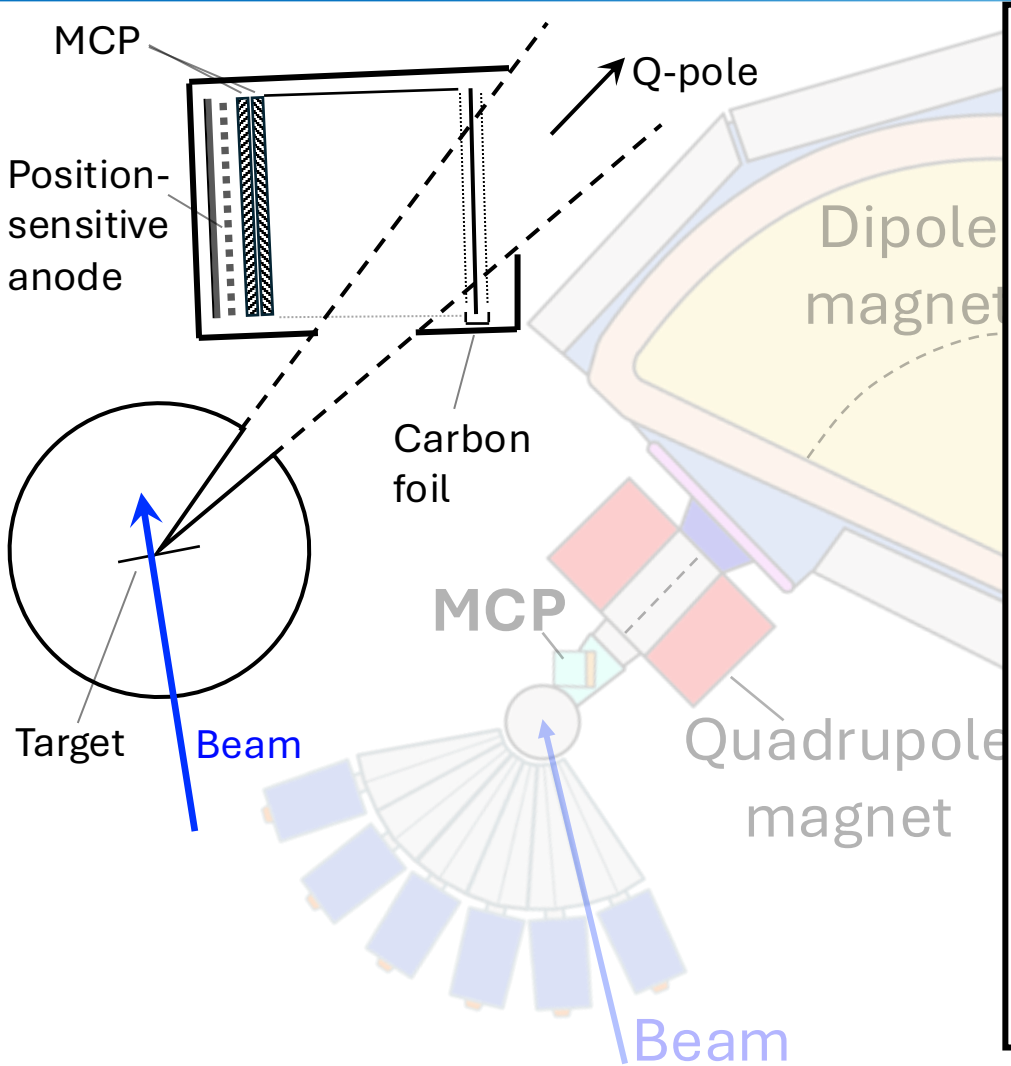

# Micro Channel Plate (MCP)

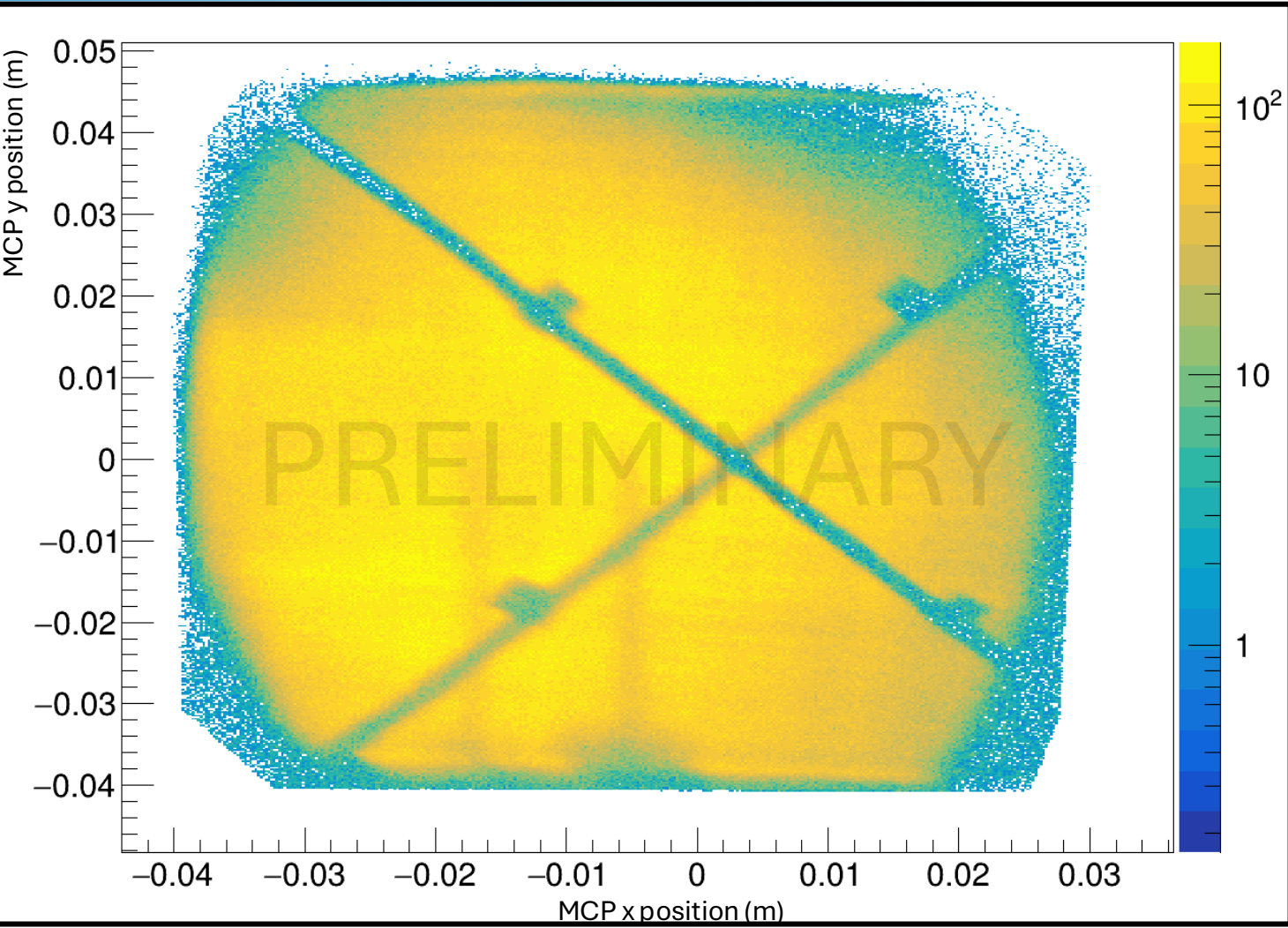
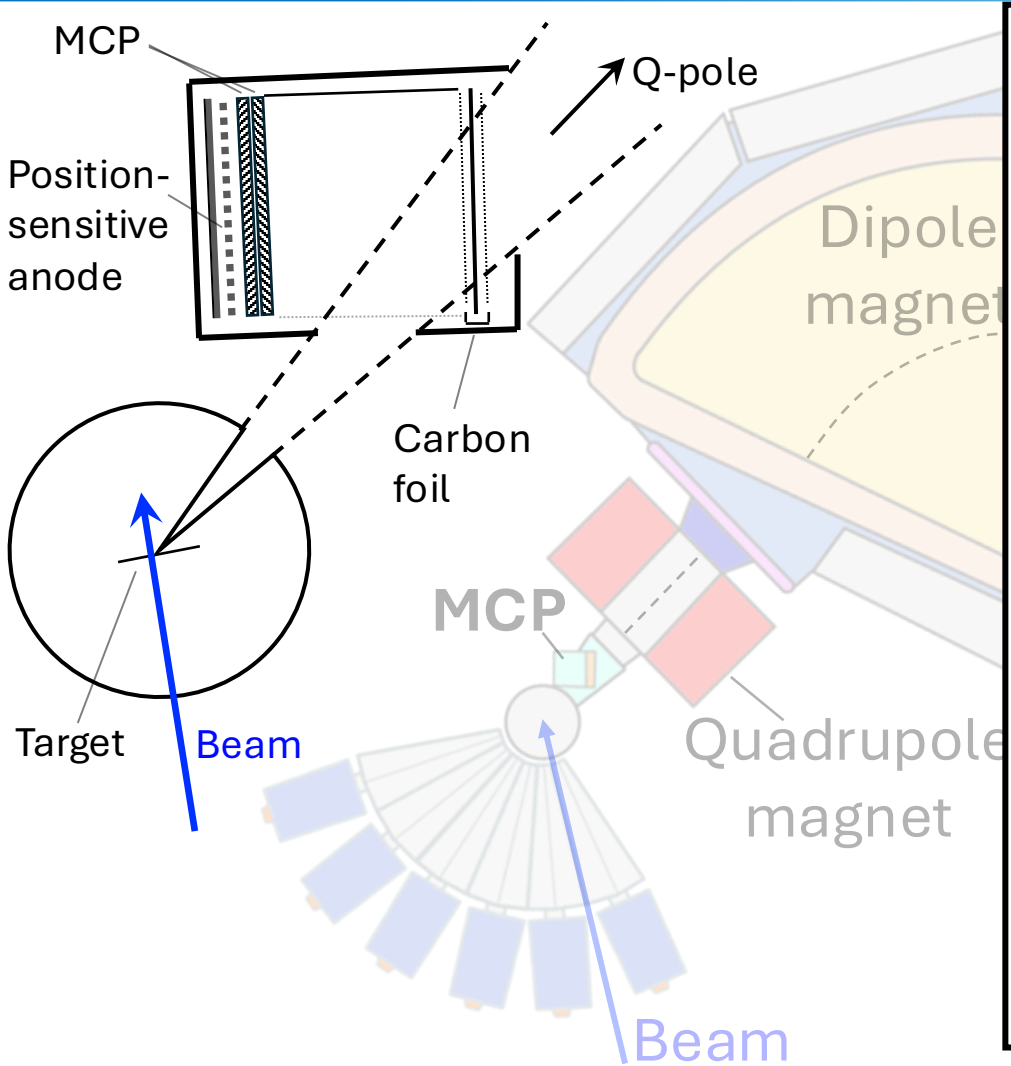

# MultiWire Parallel Plate Avalanche Counter (MWPPAC)

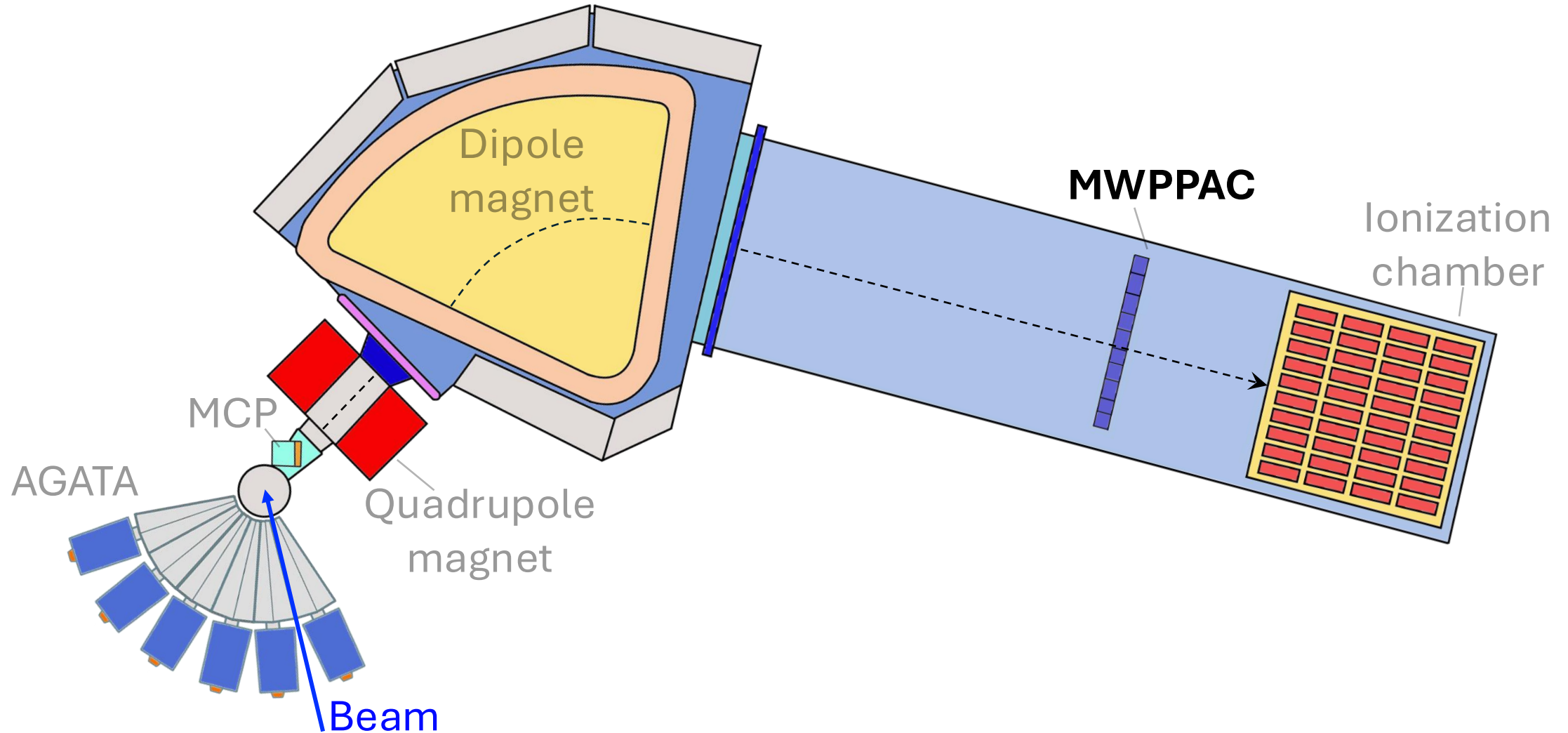

# MultiWire Parallel Plate Avalanche Counter (MWPPAC)

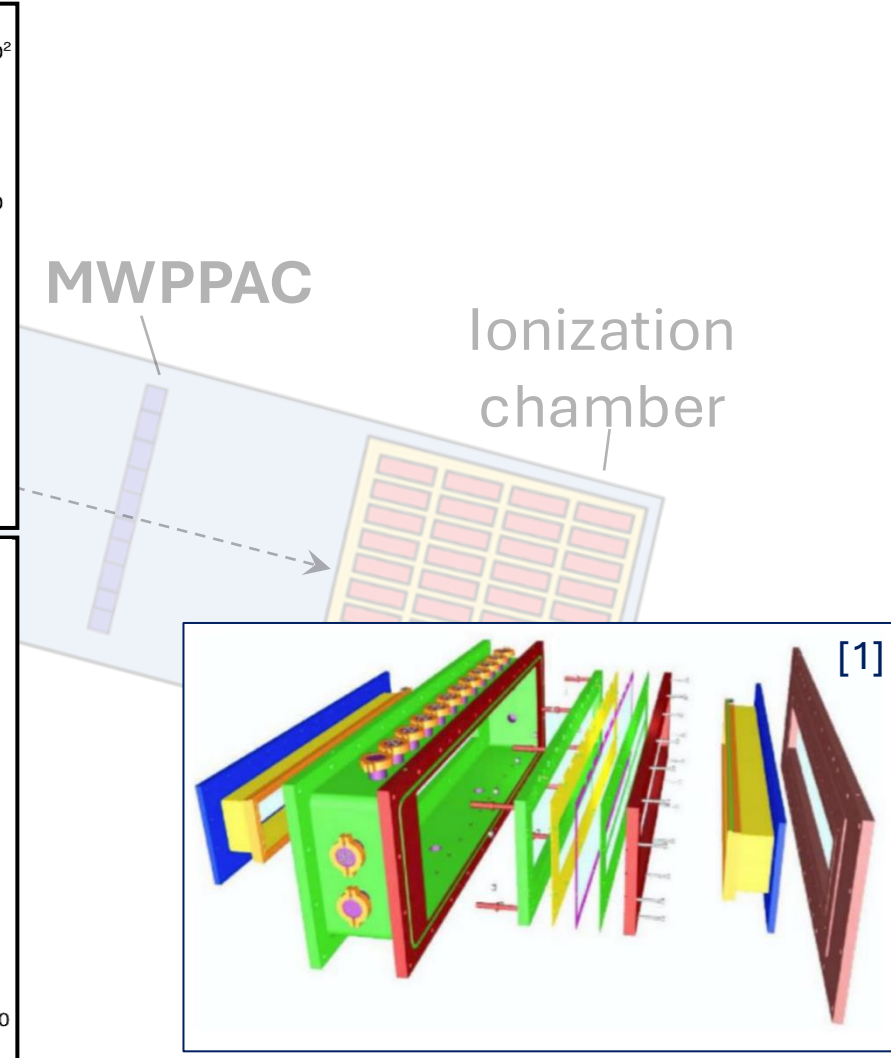
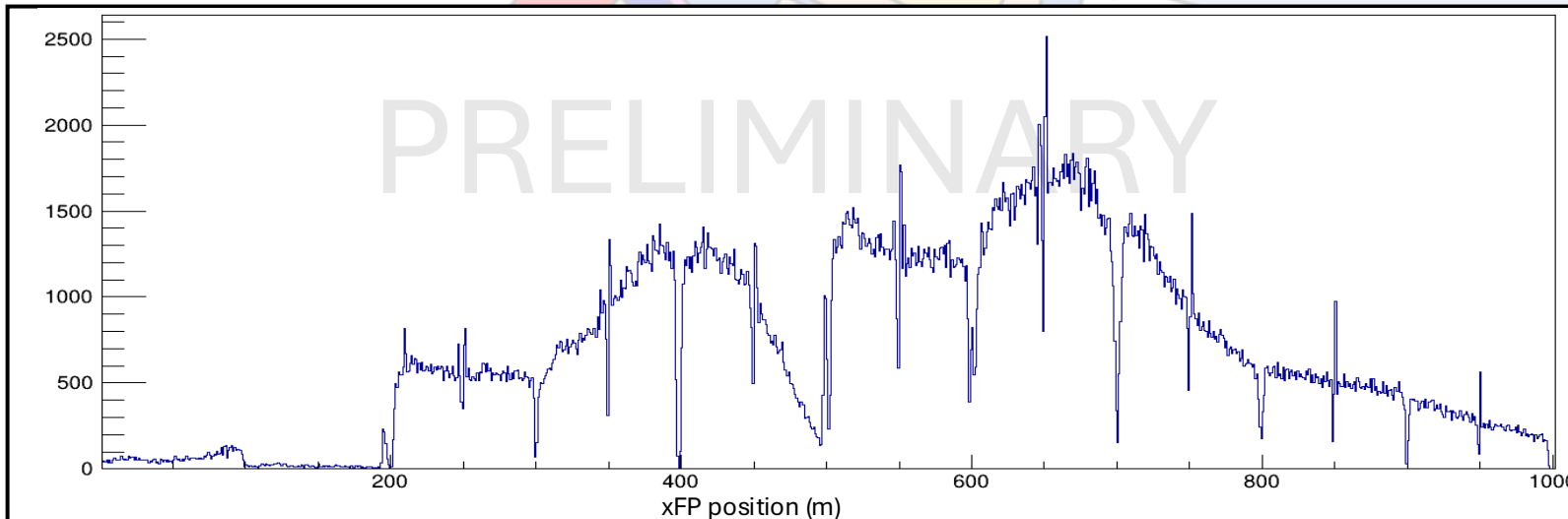
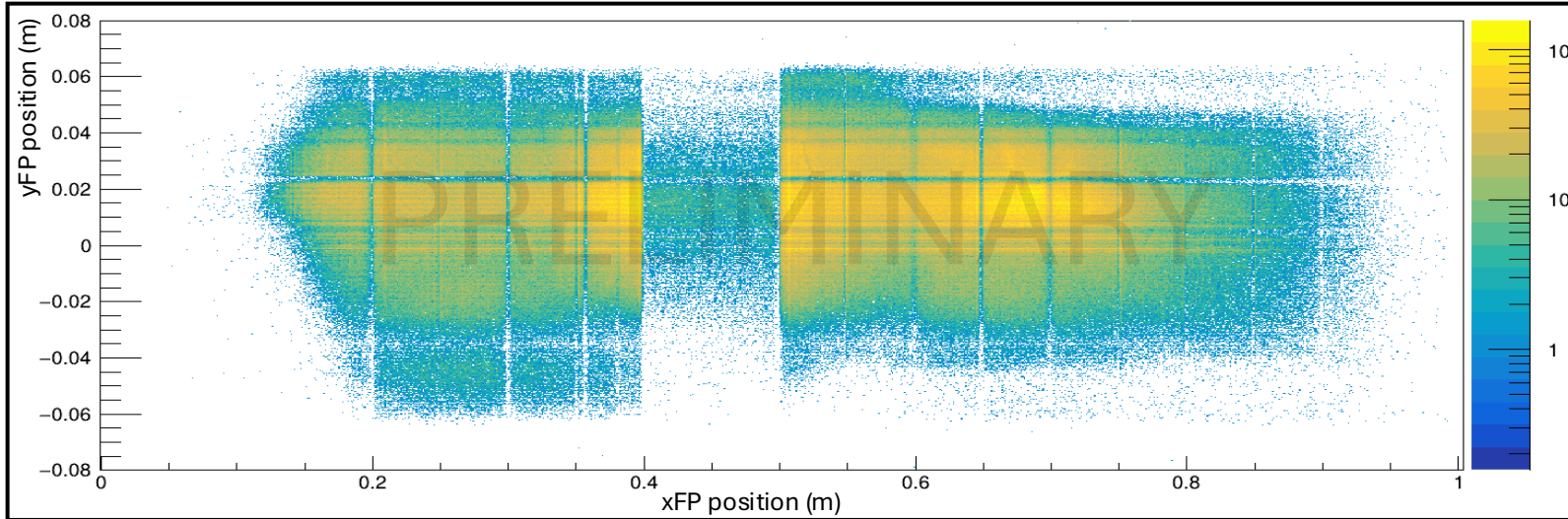

# MultiWire Parallel Plate Avalanche Counter (MWPPAC)

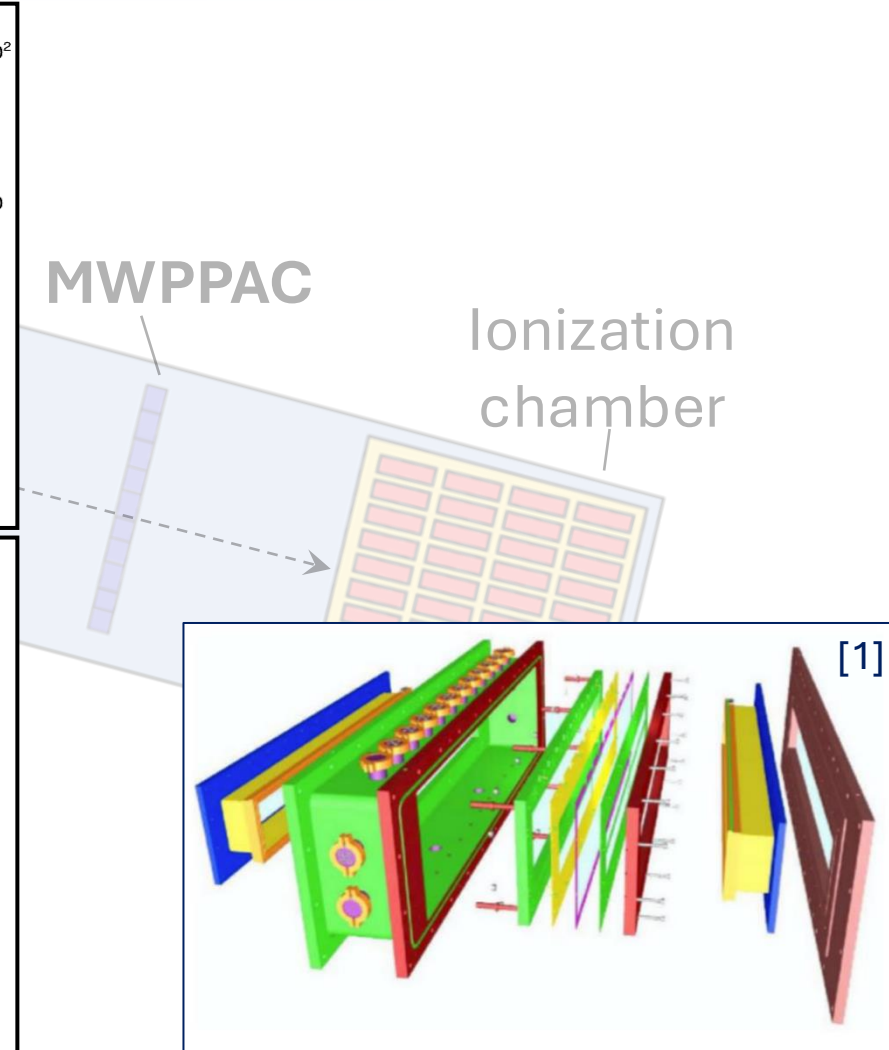
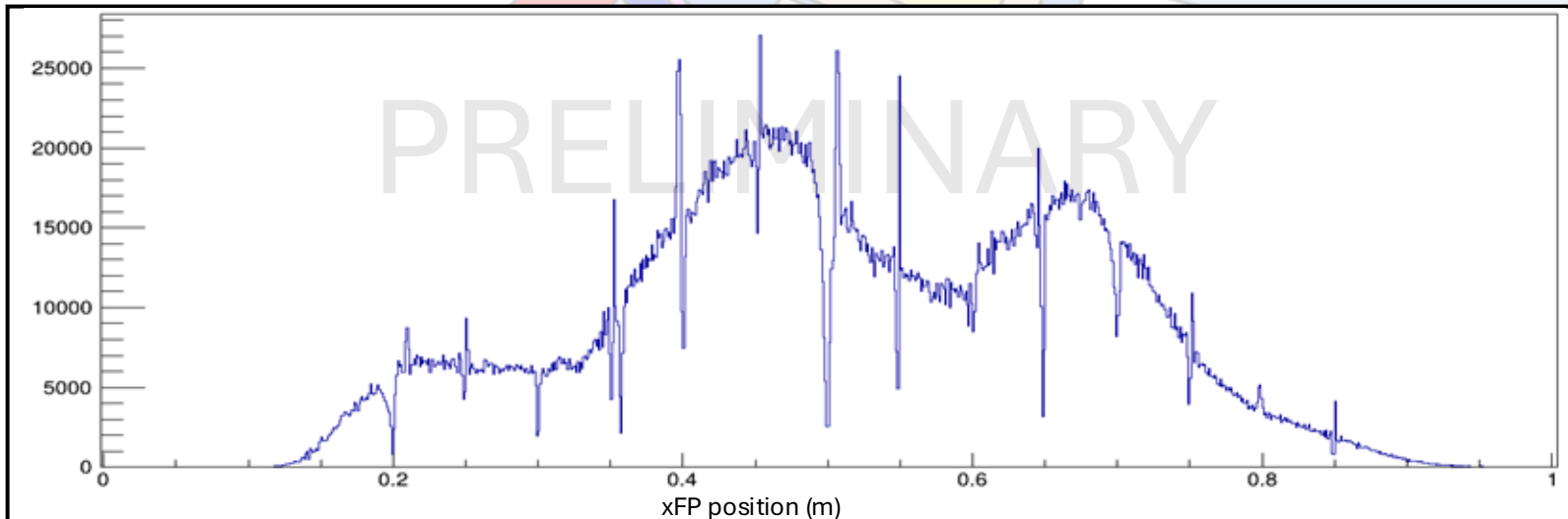
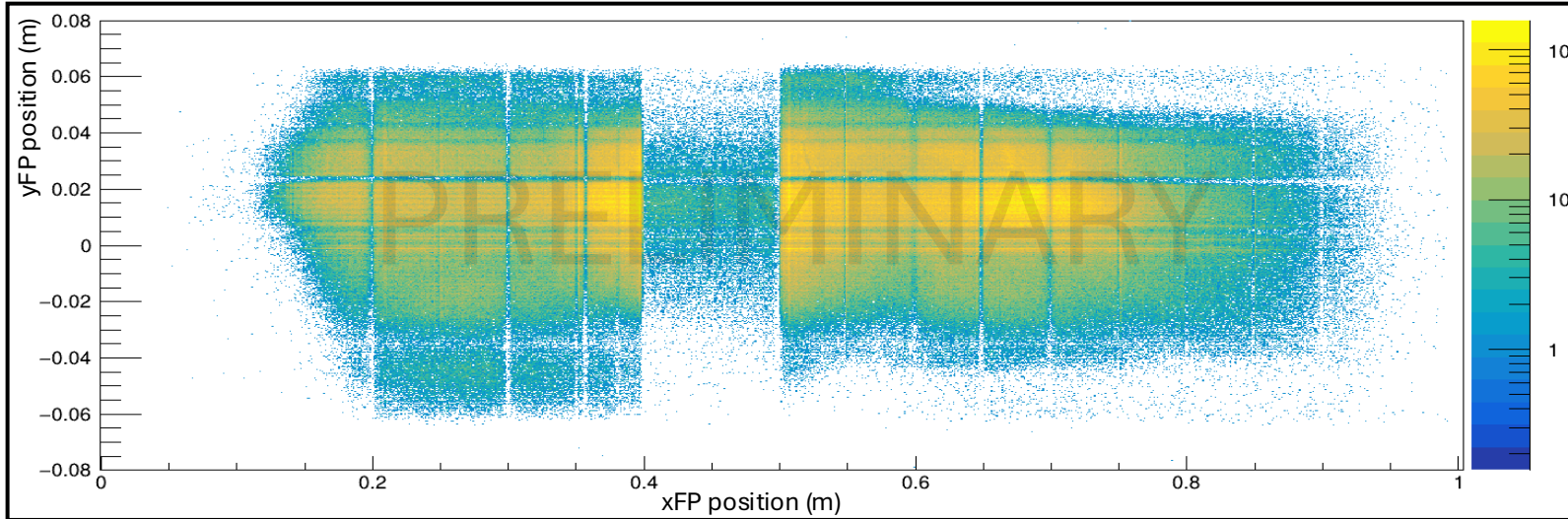

# MultiWire Parallel Plate Avalanche Counter (MWPPAC)

tof : x focal plane

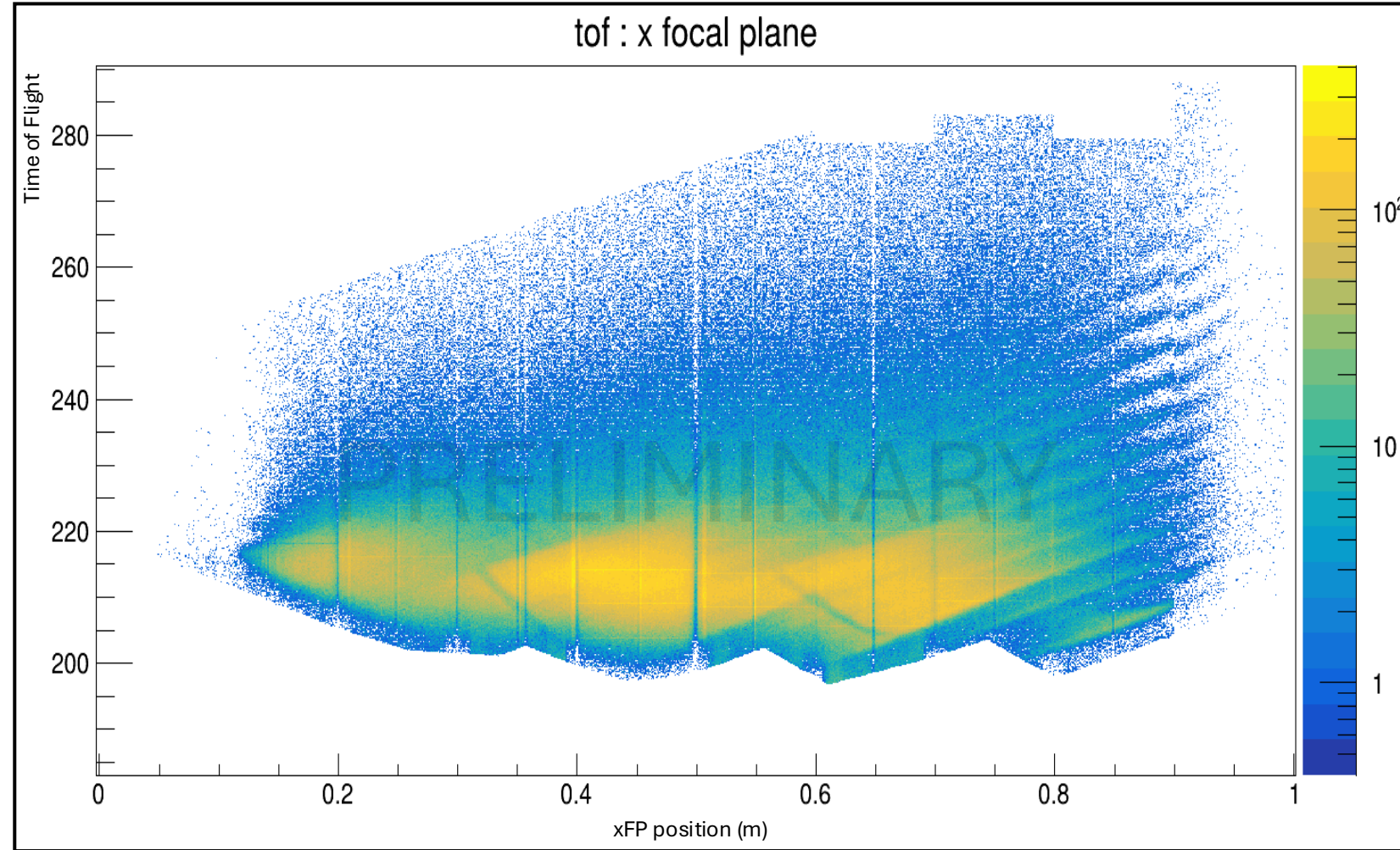

MWPPAC

Ionization chamber

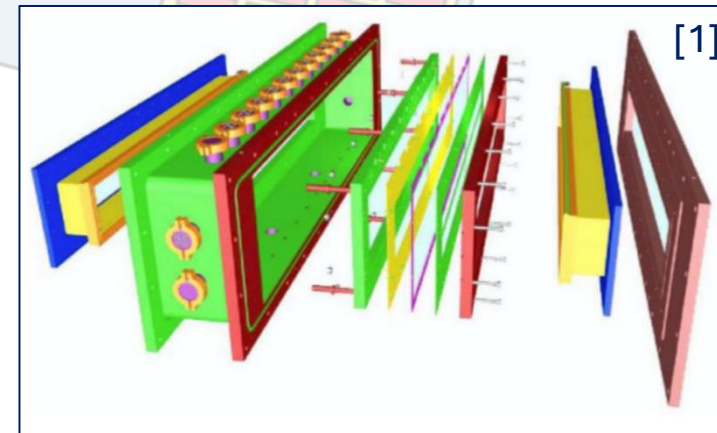

\Beam

# Ionization chamber (IC)

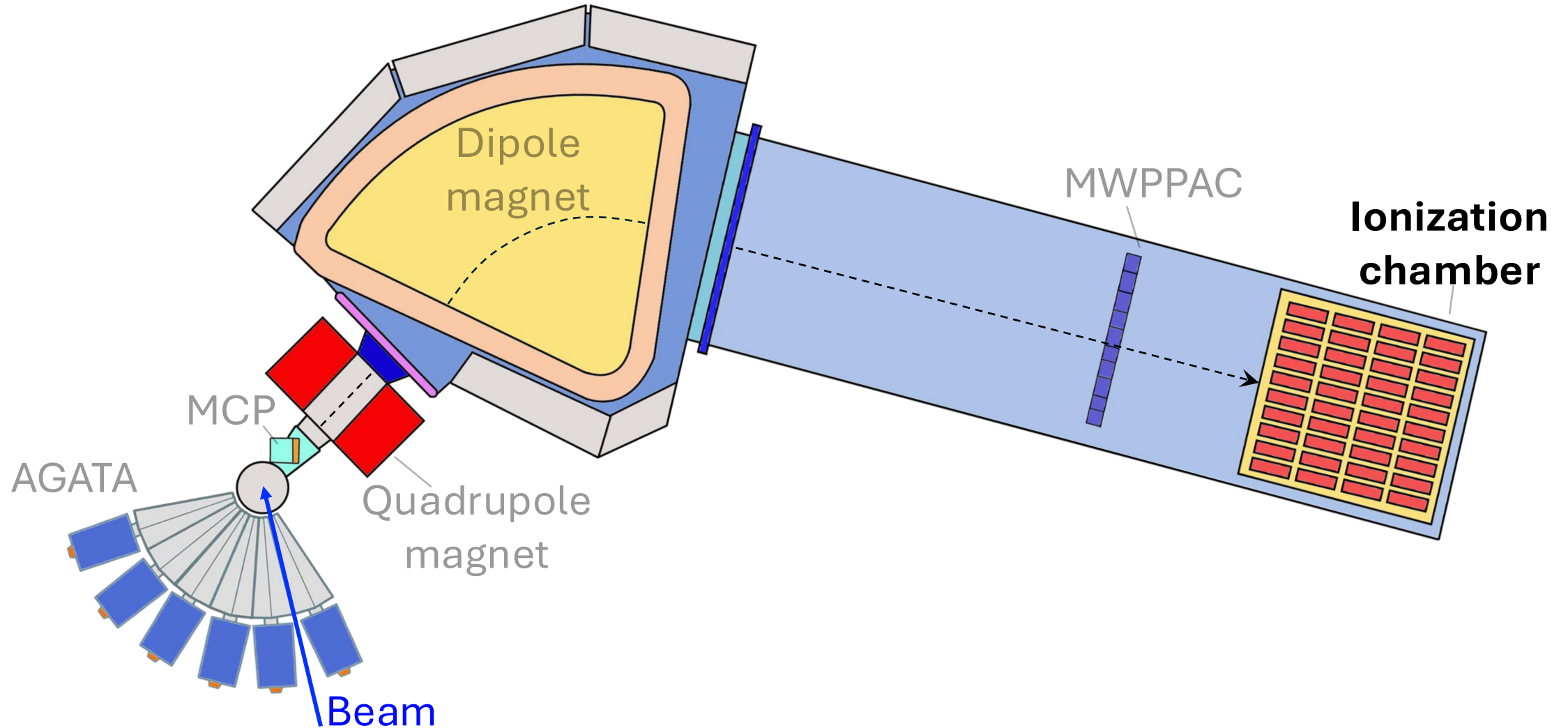

# Ionization chamber (IC)

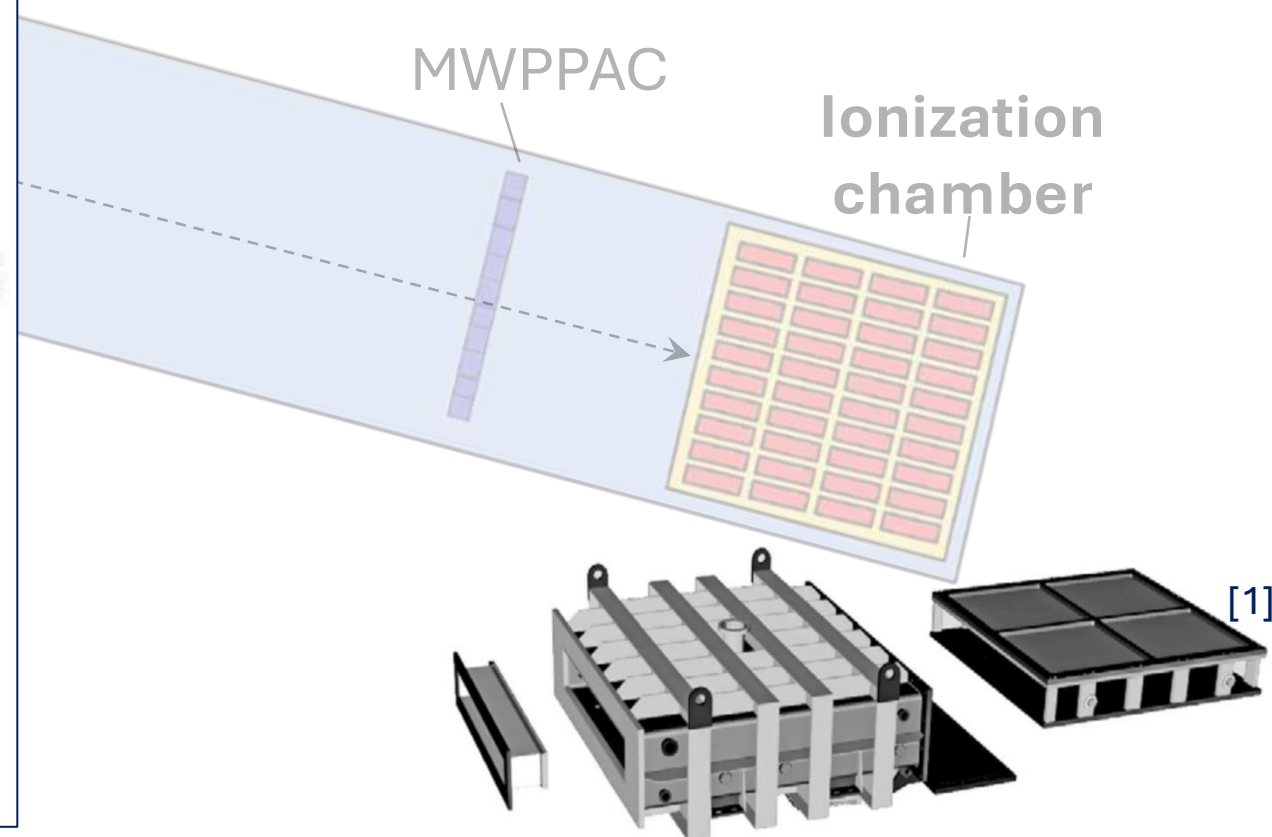
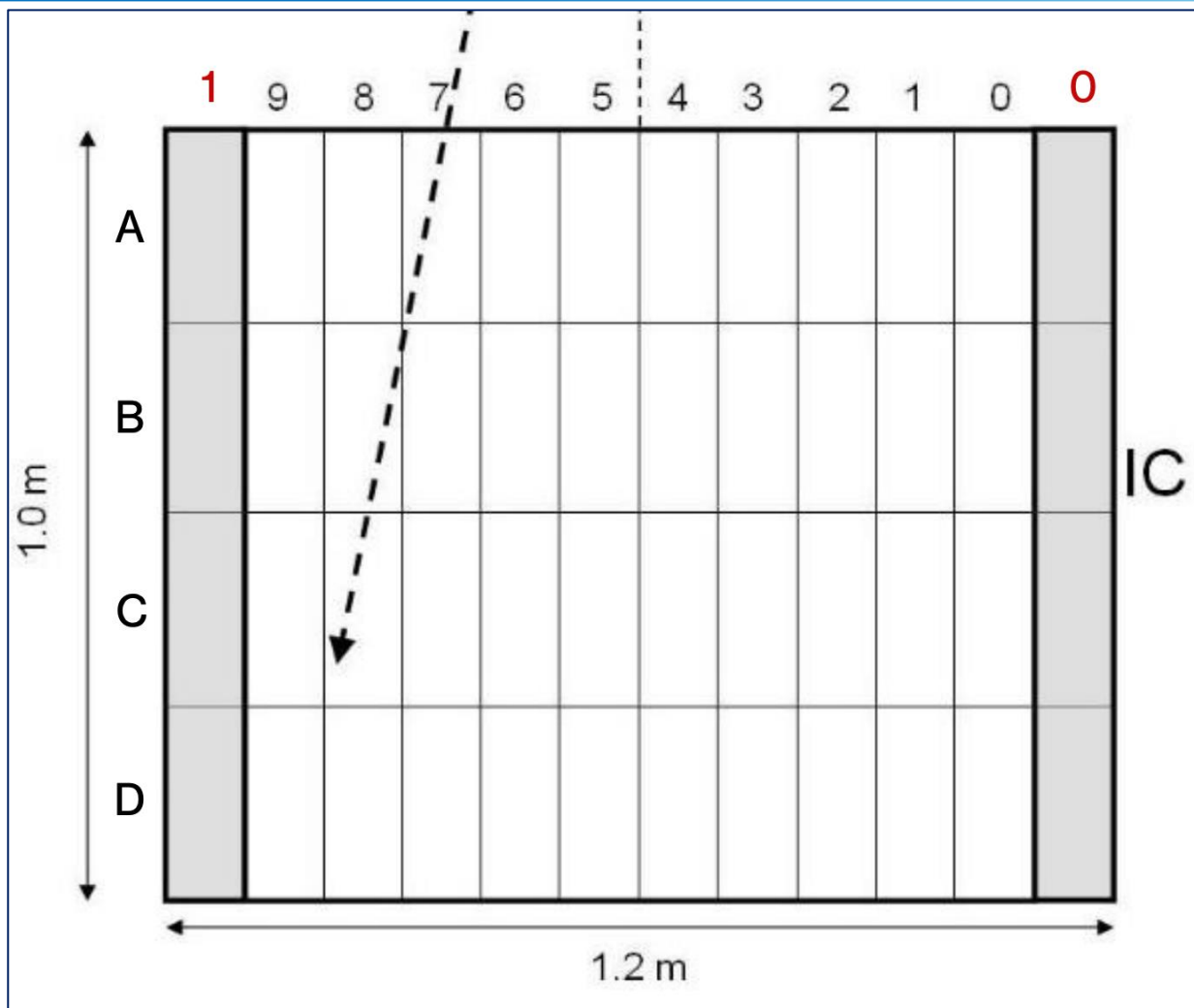

# Ionization chamber (IC)

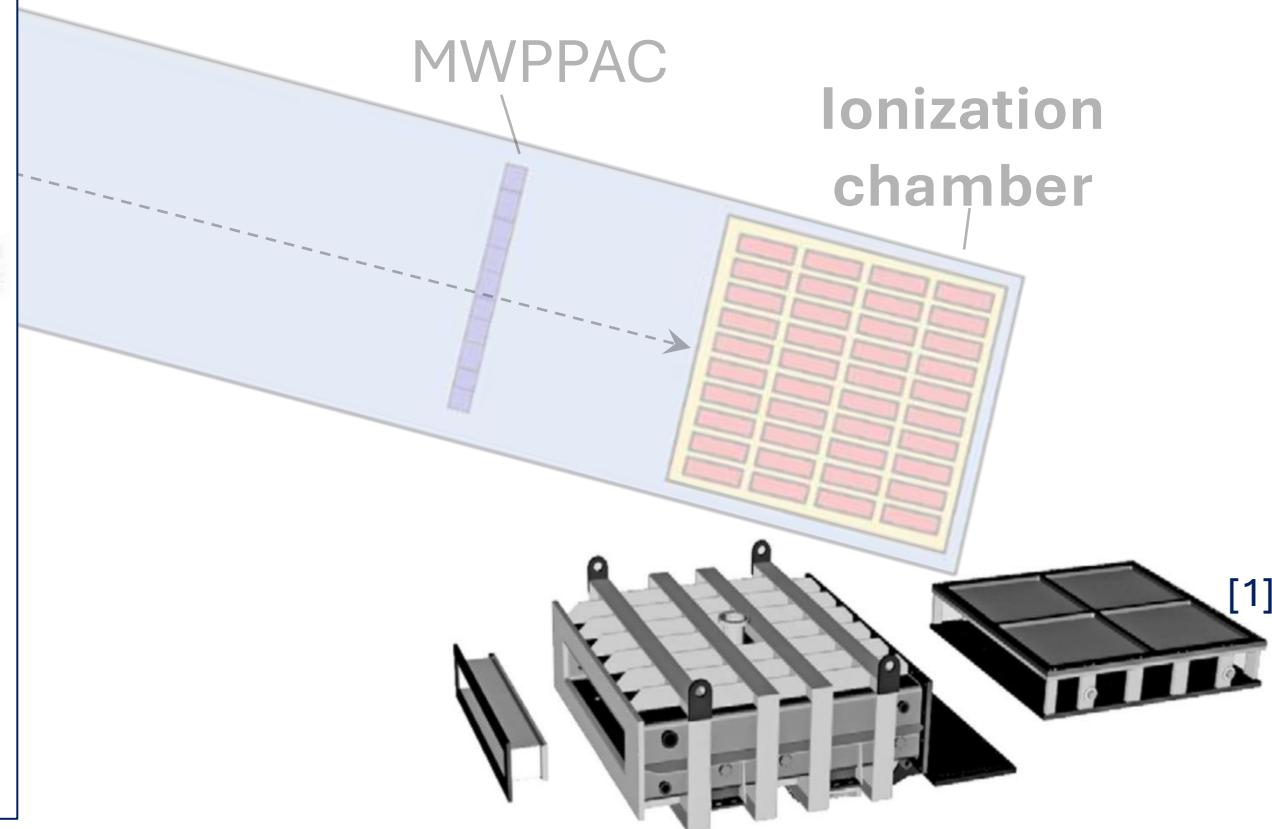
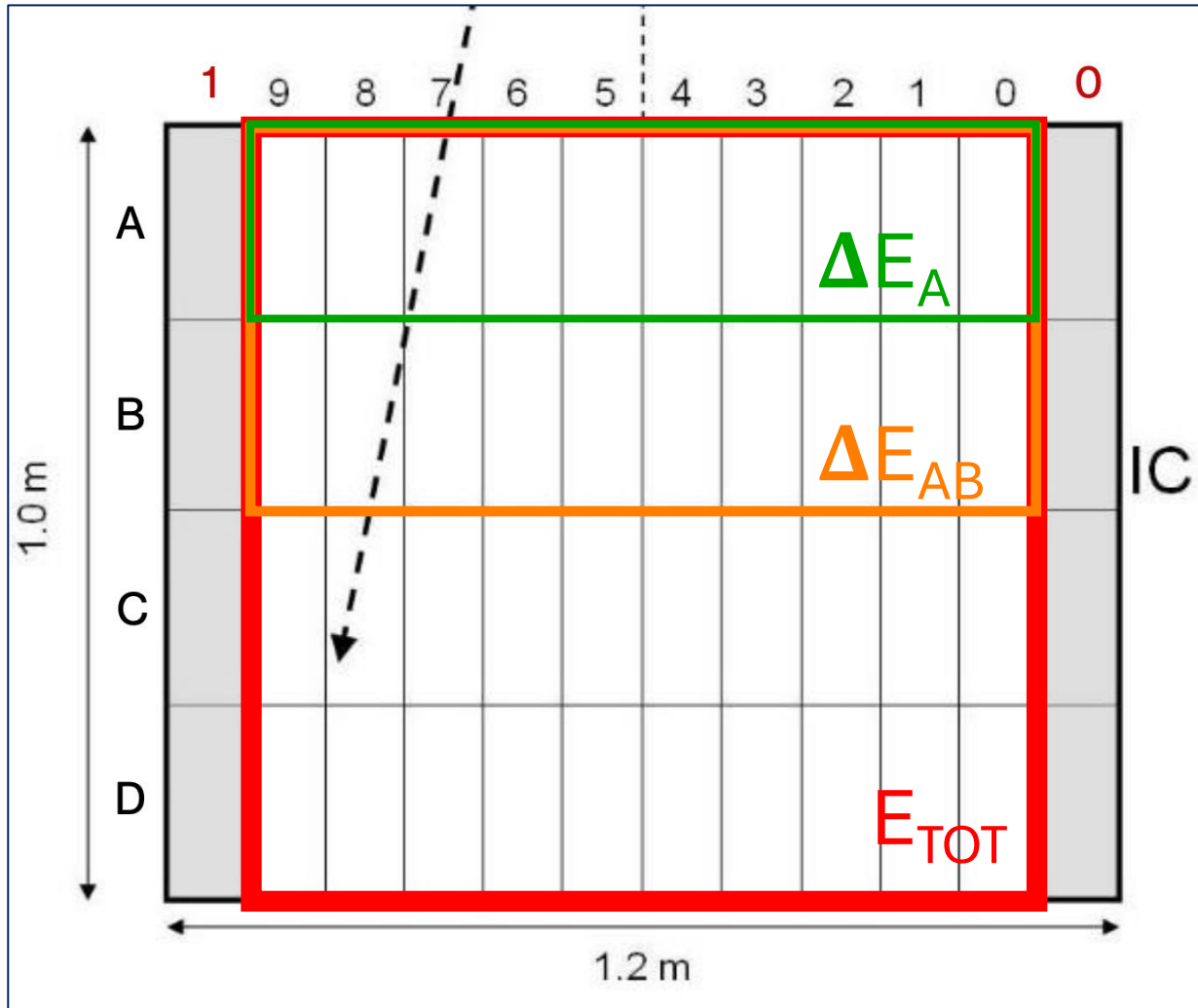

# Ionization chamber (IC)

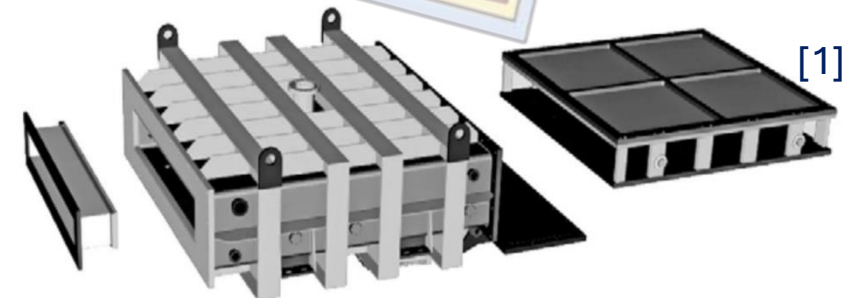
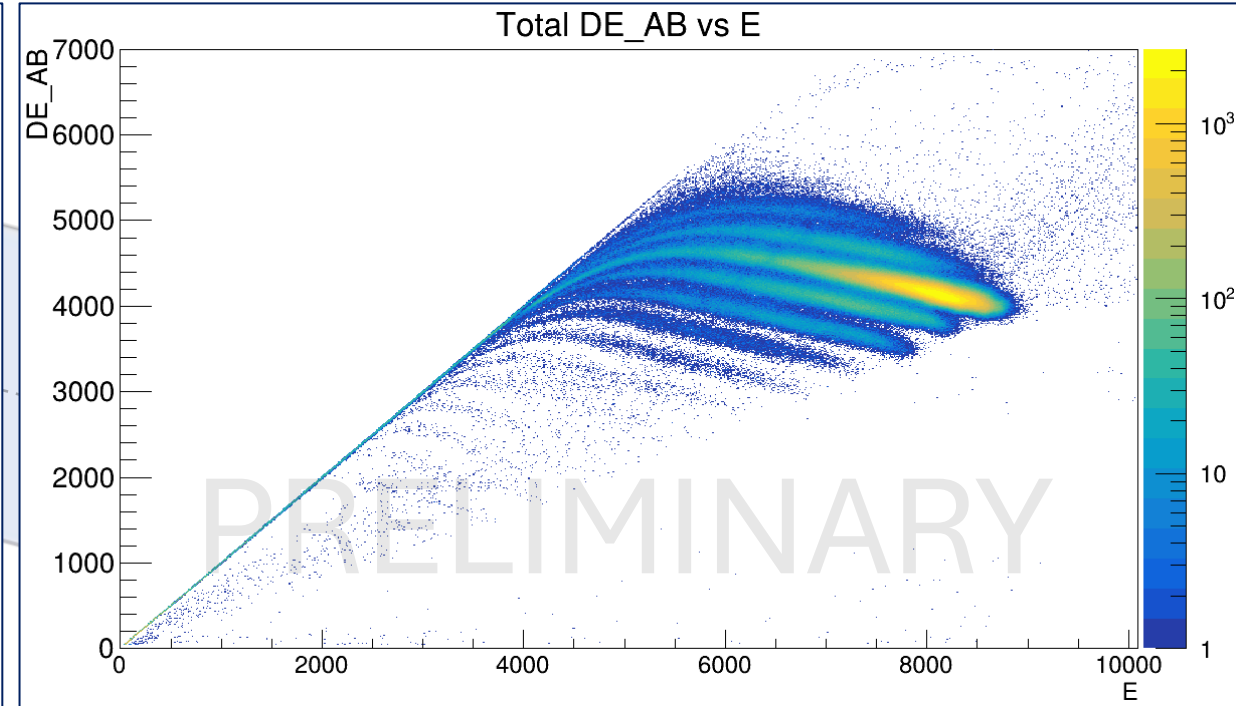
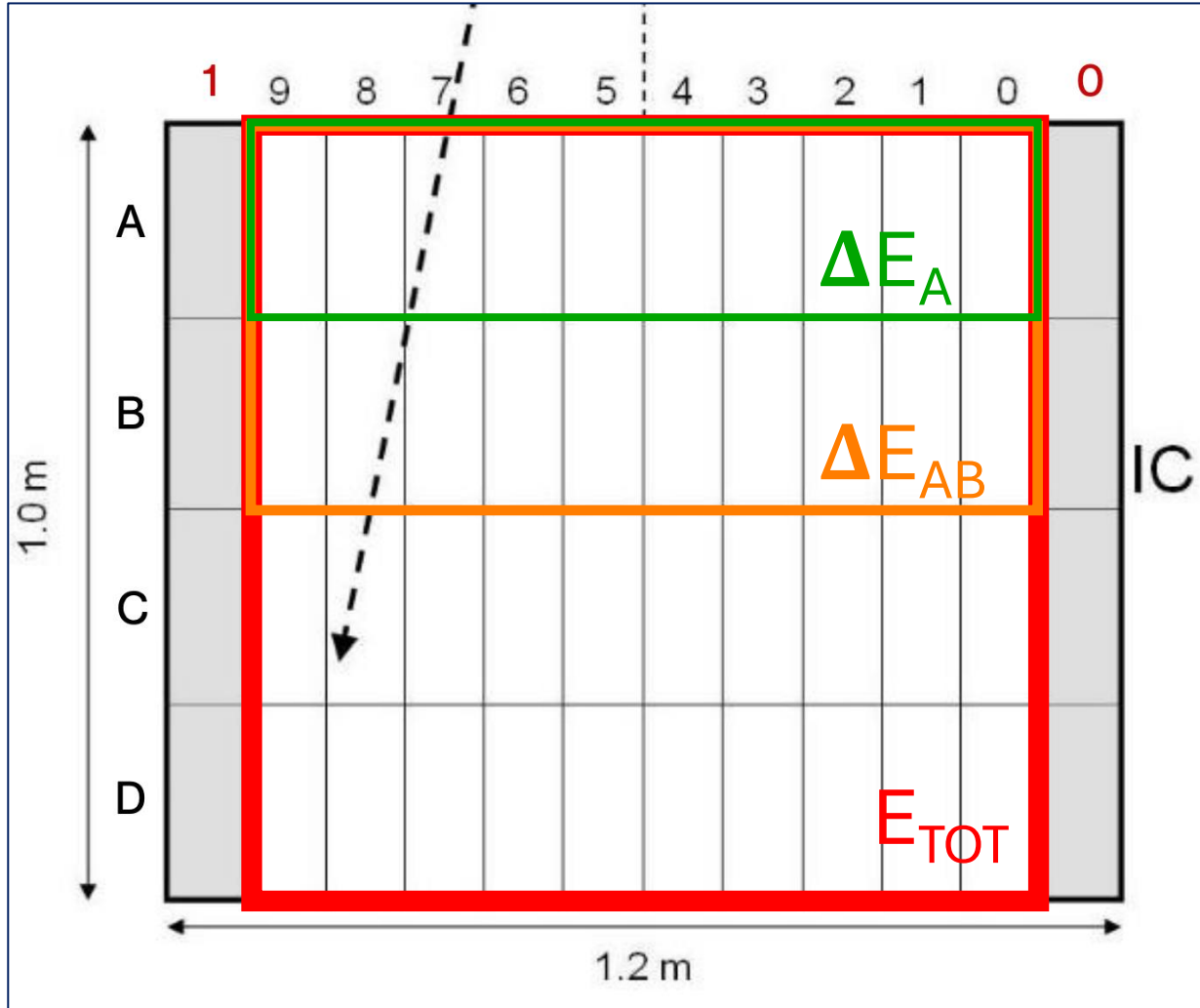

# Ionization chamber (IC)

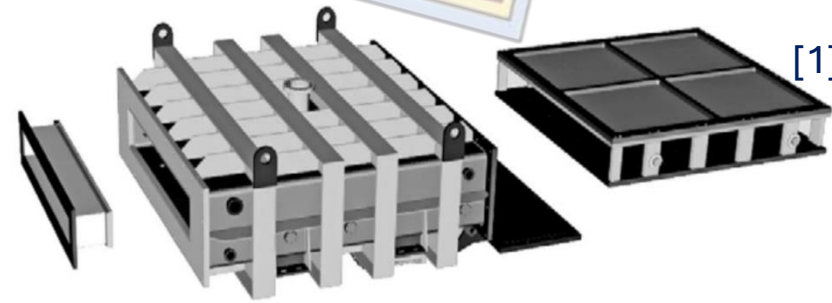
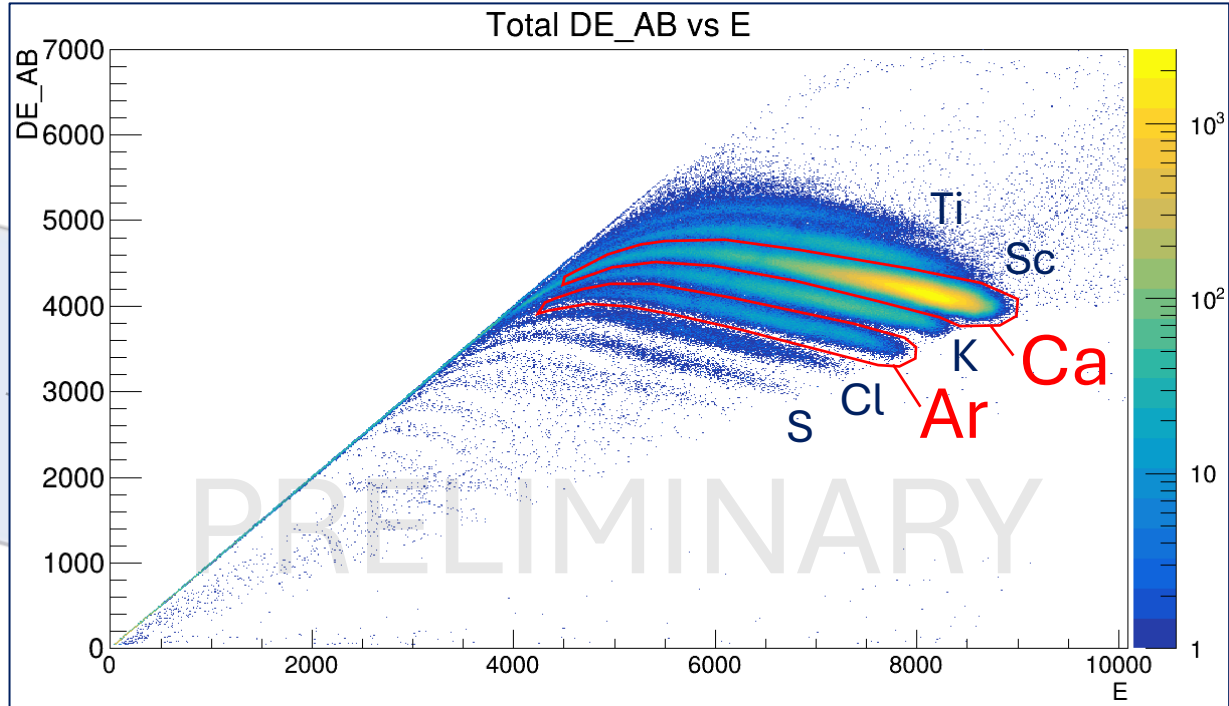
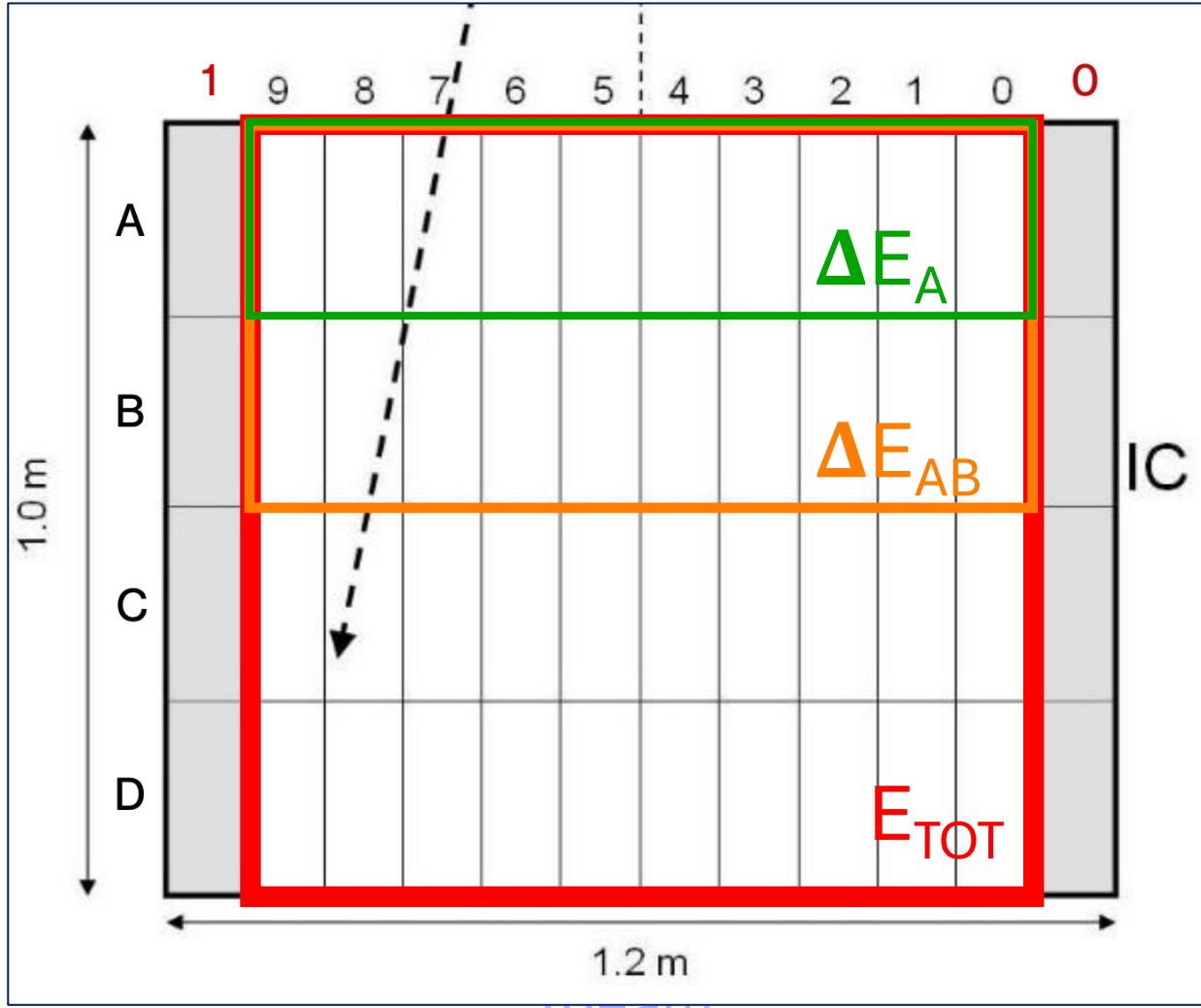

[1] S. Beghini et al., NIM A 551 (2005) 364-374

# Ionization chamber (IC)

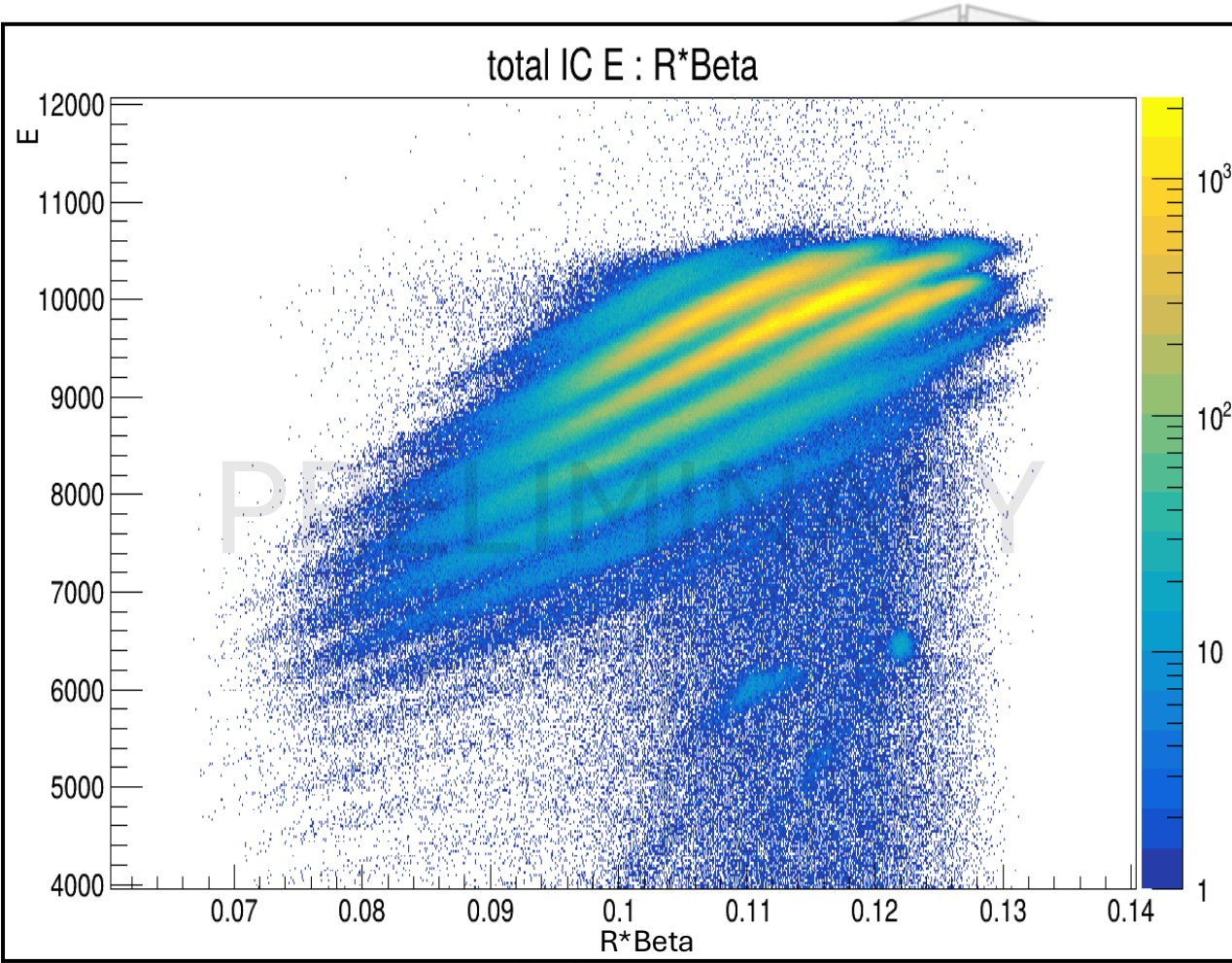

\Beam

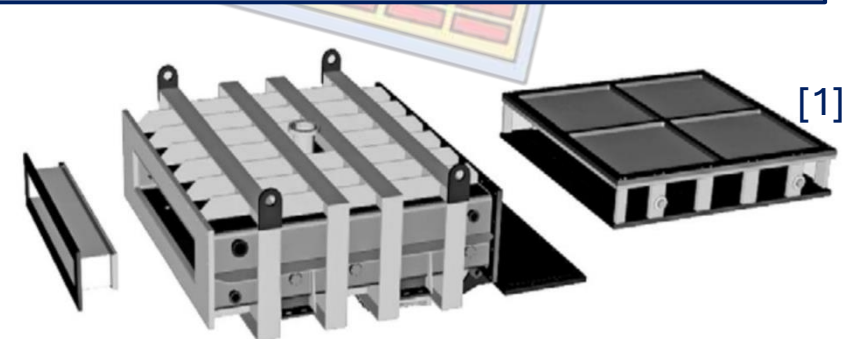
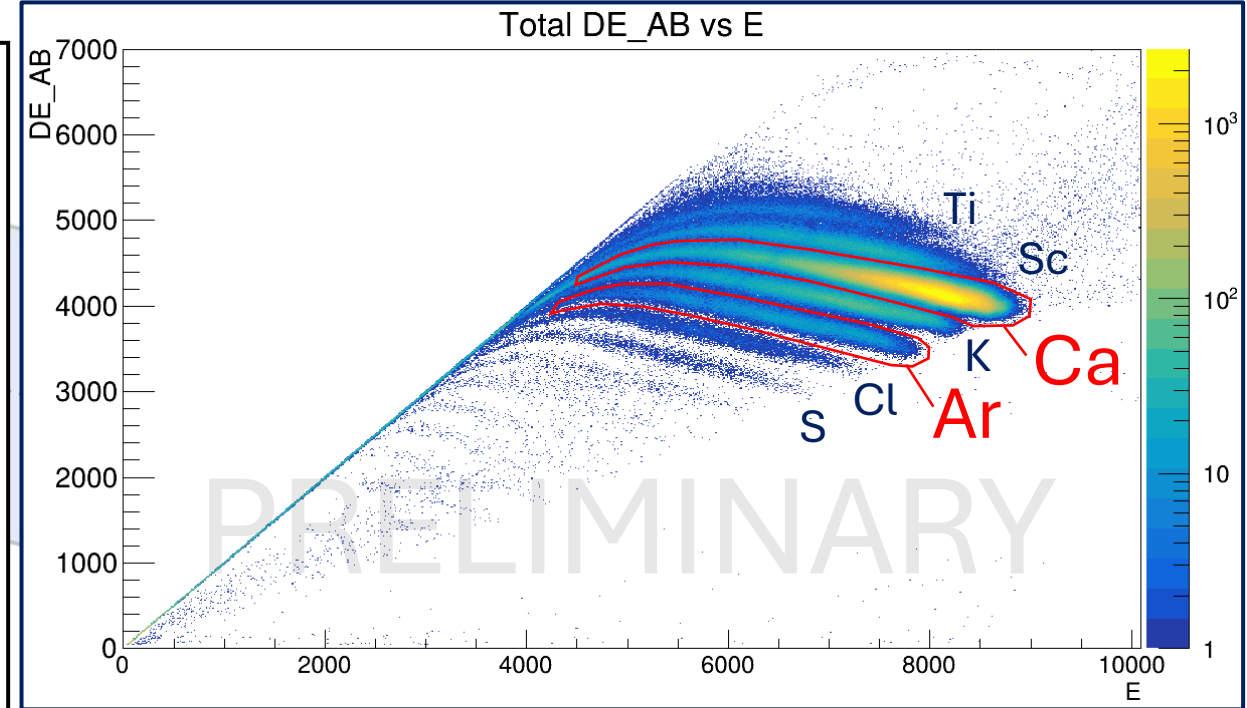

[1] S. Beghini et al., NIM A 551 (2005) 364-374

# Ionization chamber (IC)

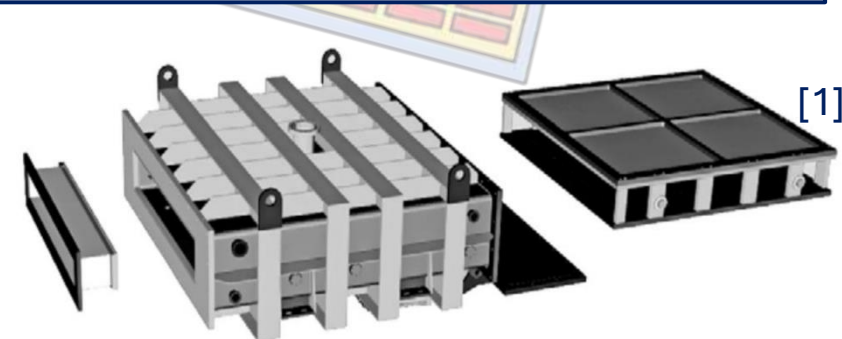
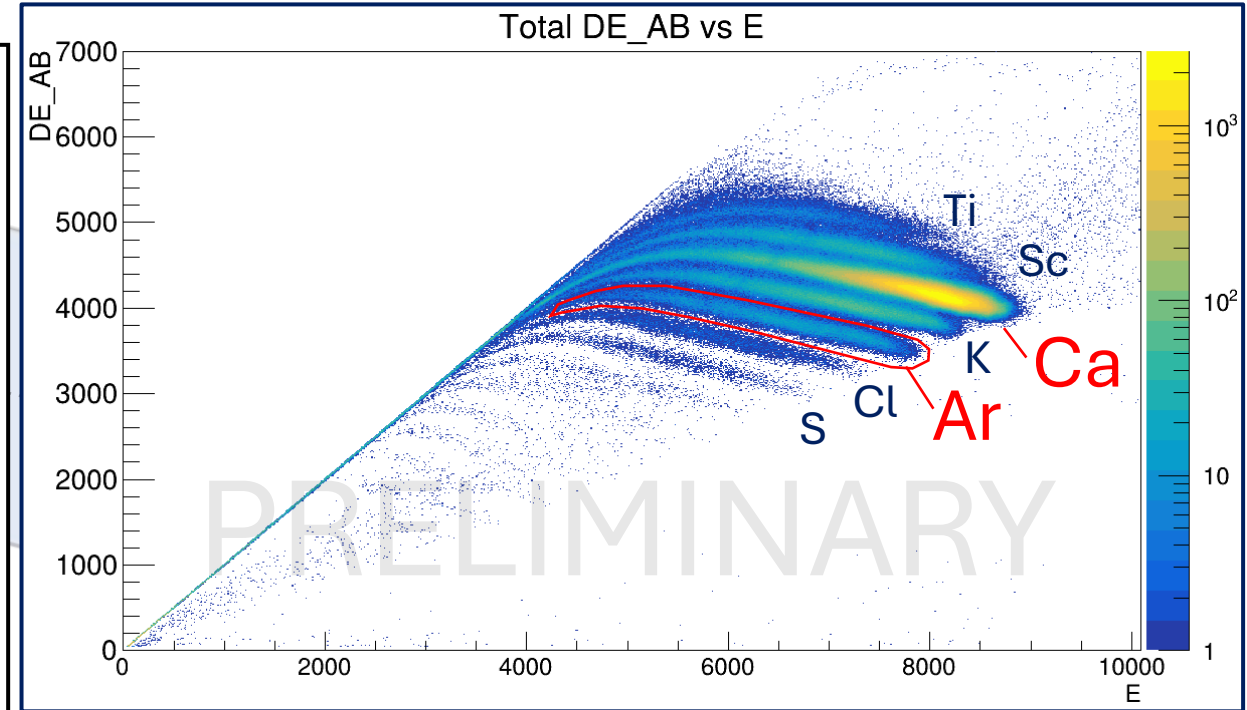
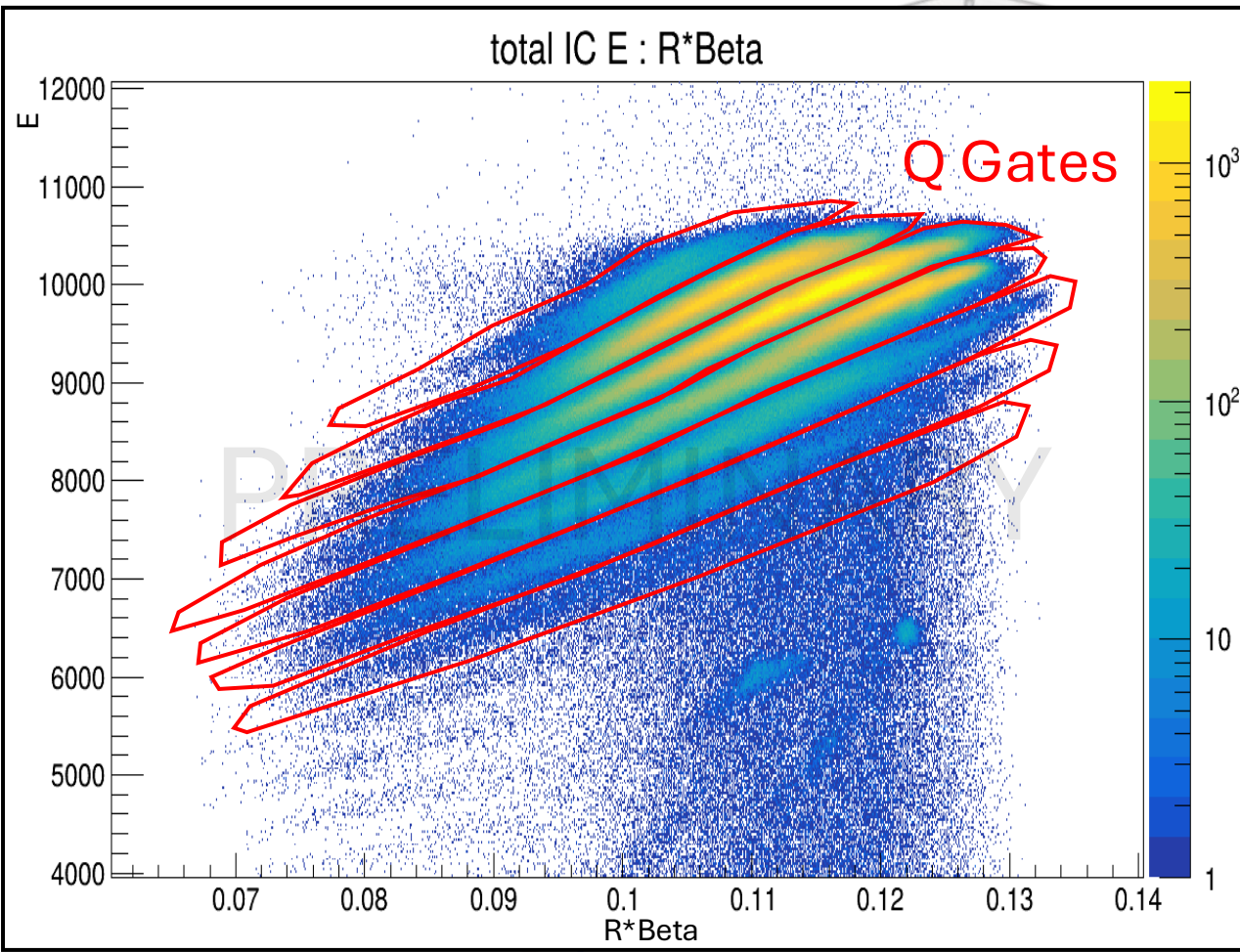

\Beam

[1] S. Beghini et al., NIM A 551 (2005) 364-374

total A/q : x focal plane

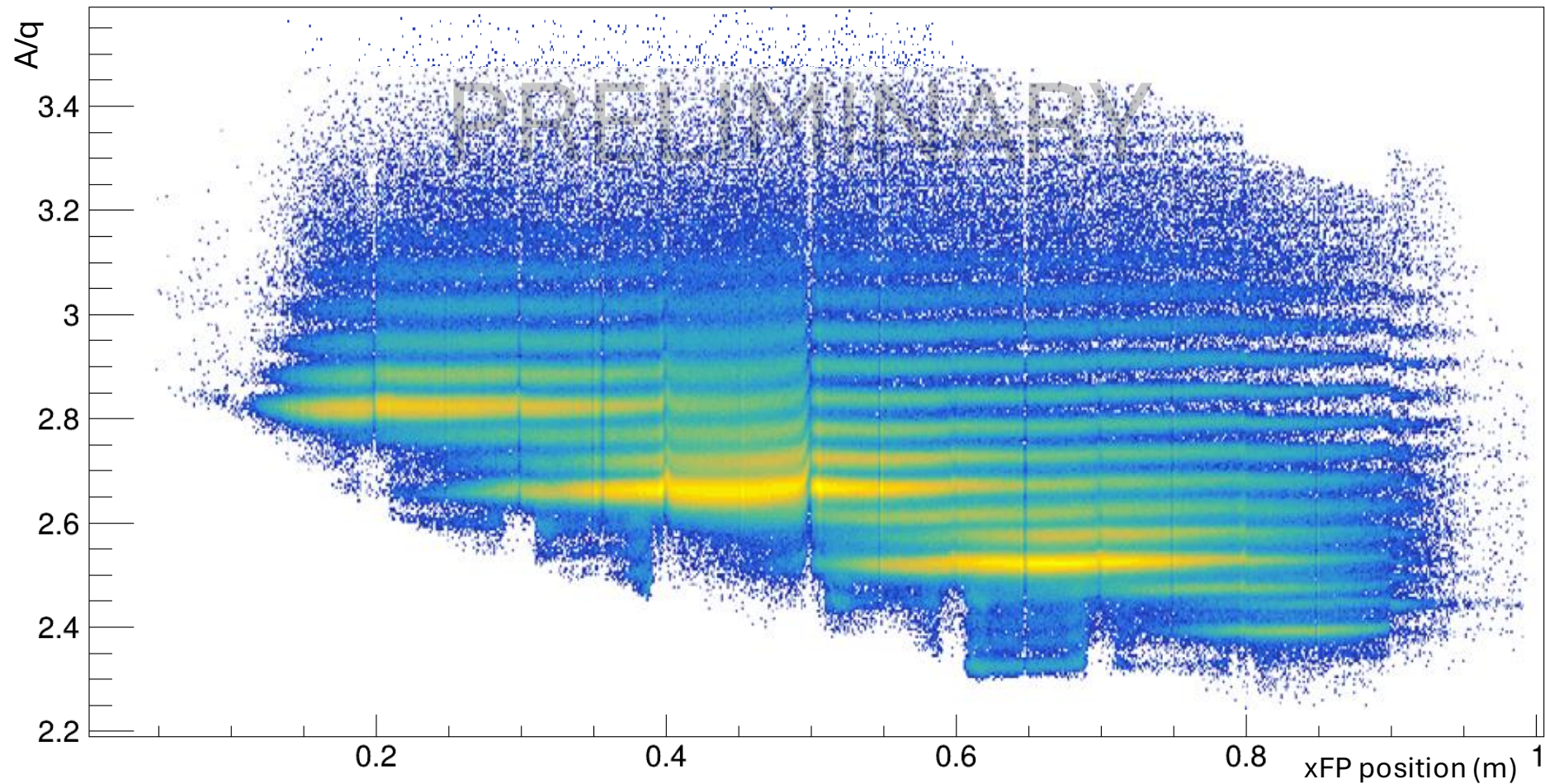

# A/q Calibration + Correction

total A/q : x focal plane

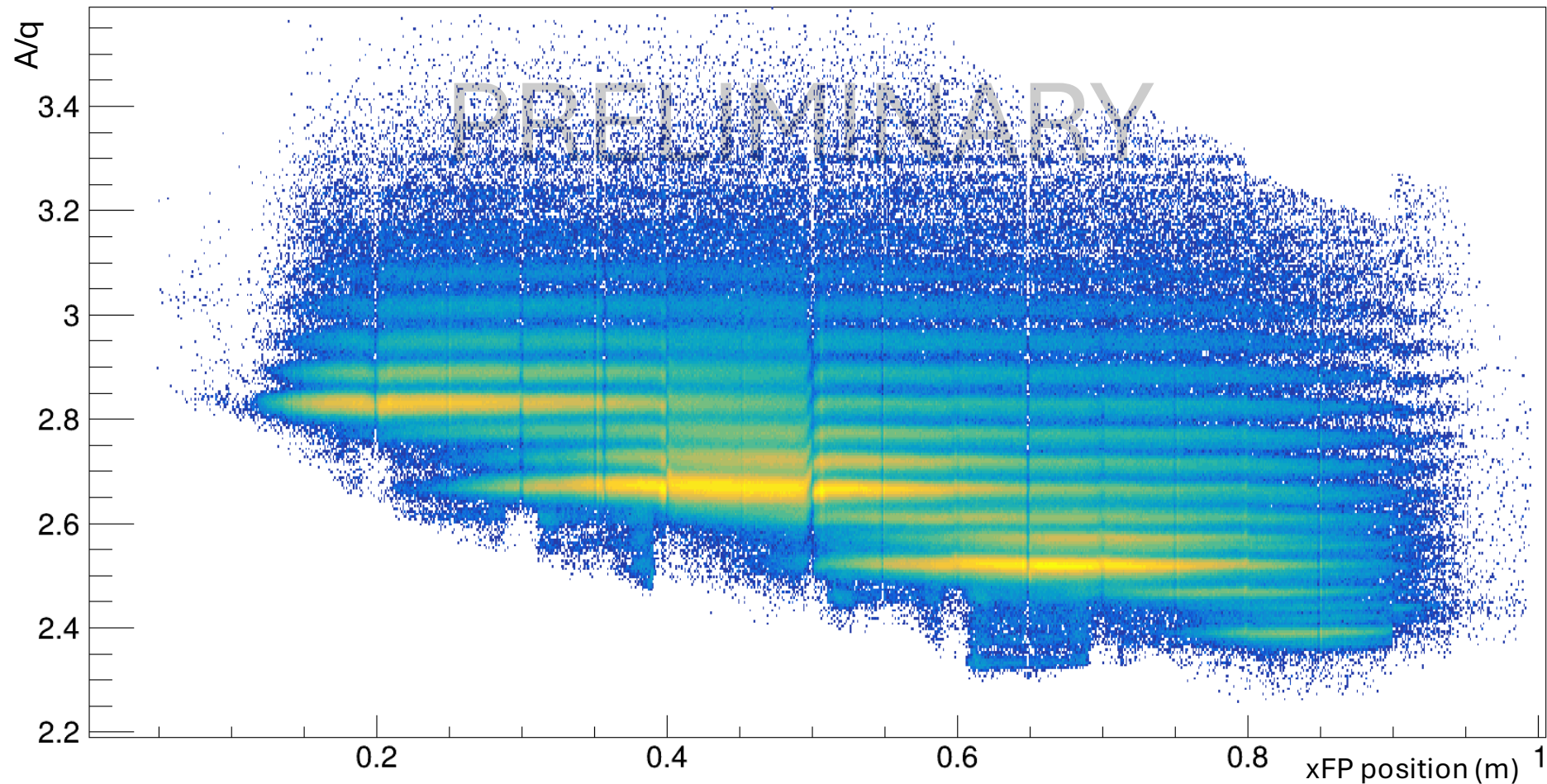

# Mass Isolation

Mass ( $Z = 18$ )

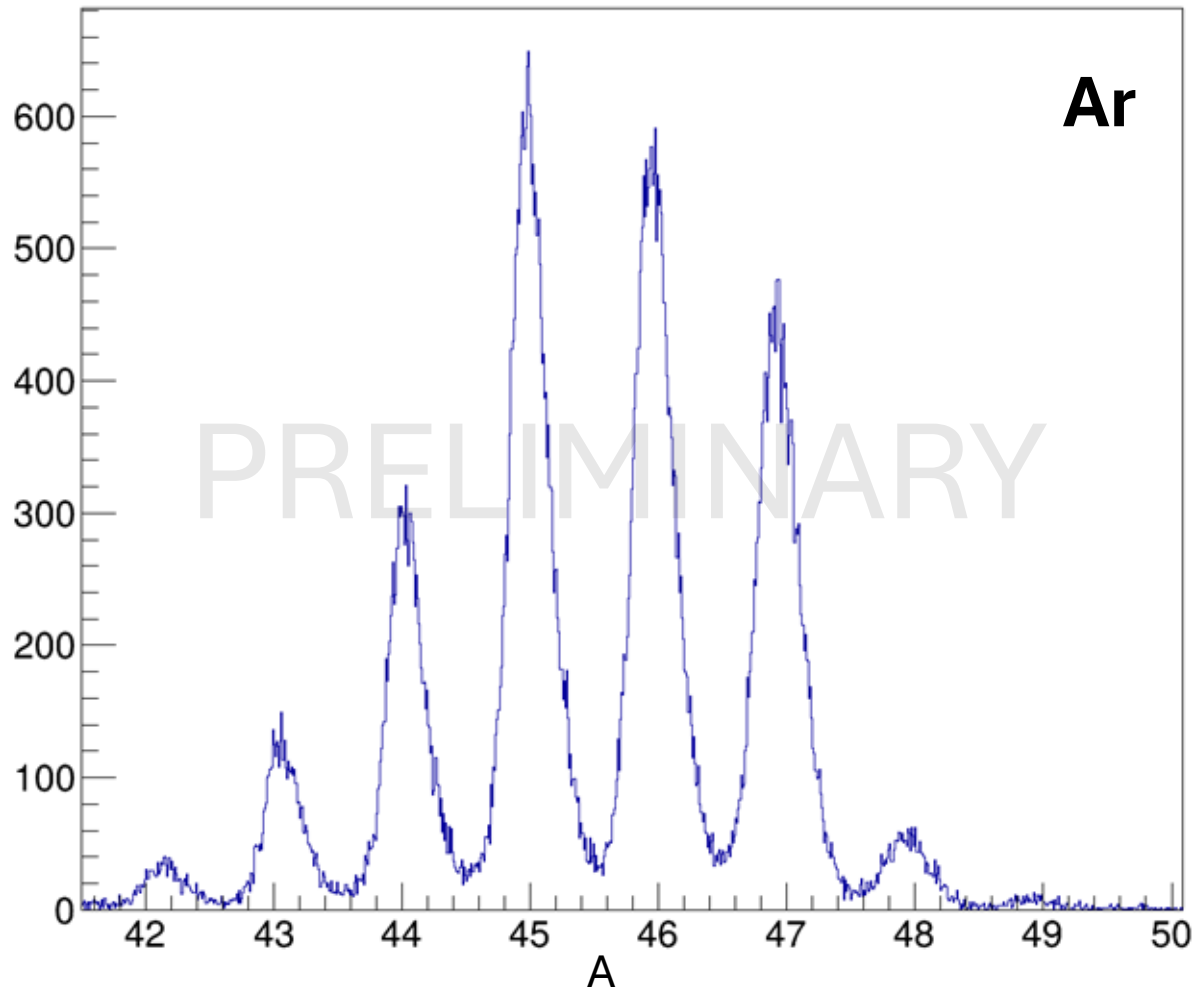

Mass ( $Z = 20$ )

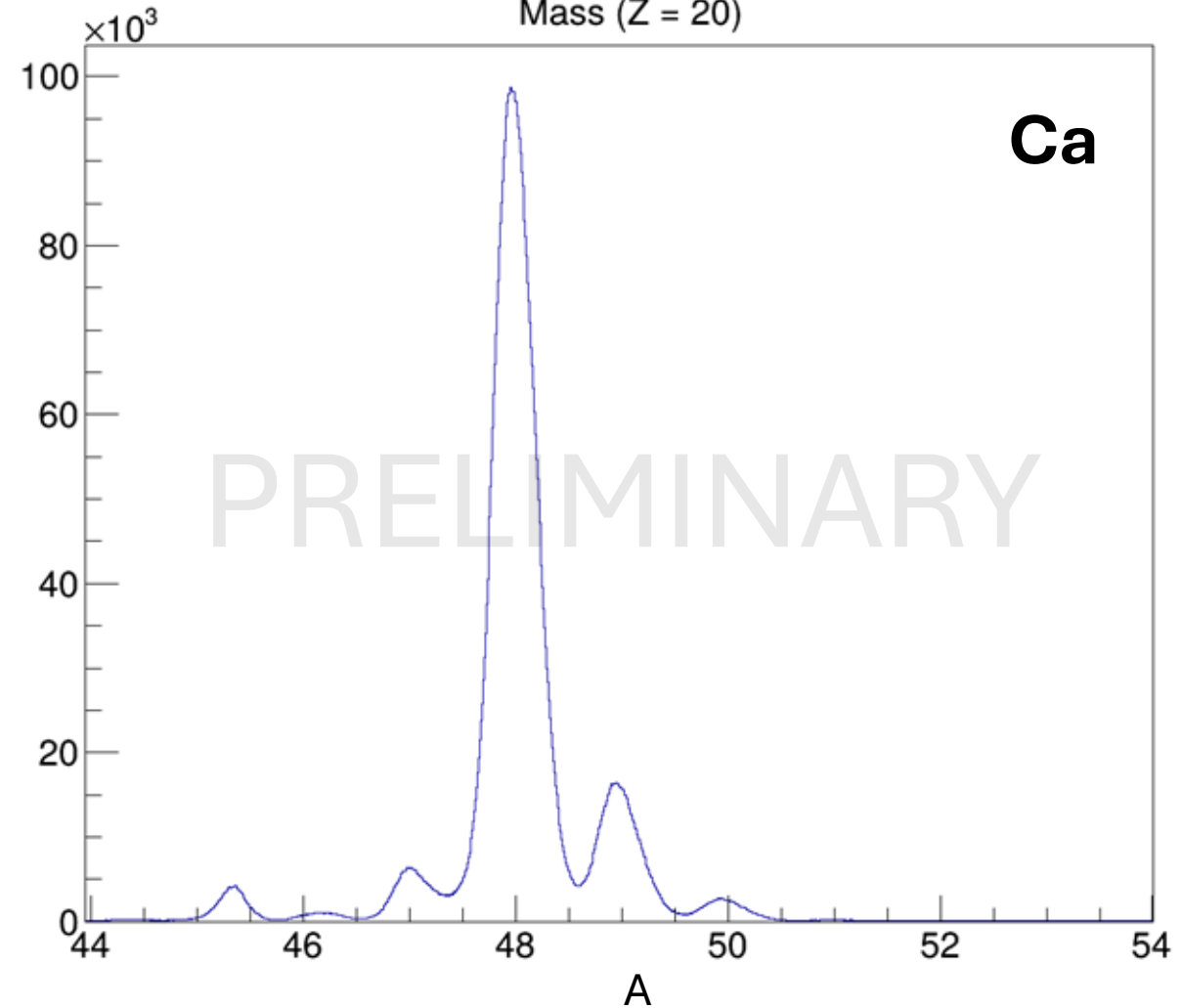

# Mass Isolation

Mass ( $Z = 18$ )

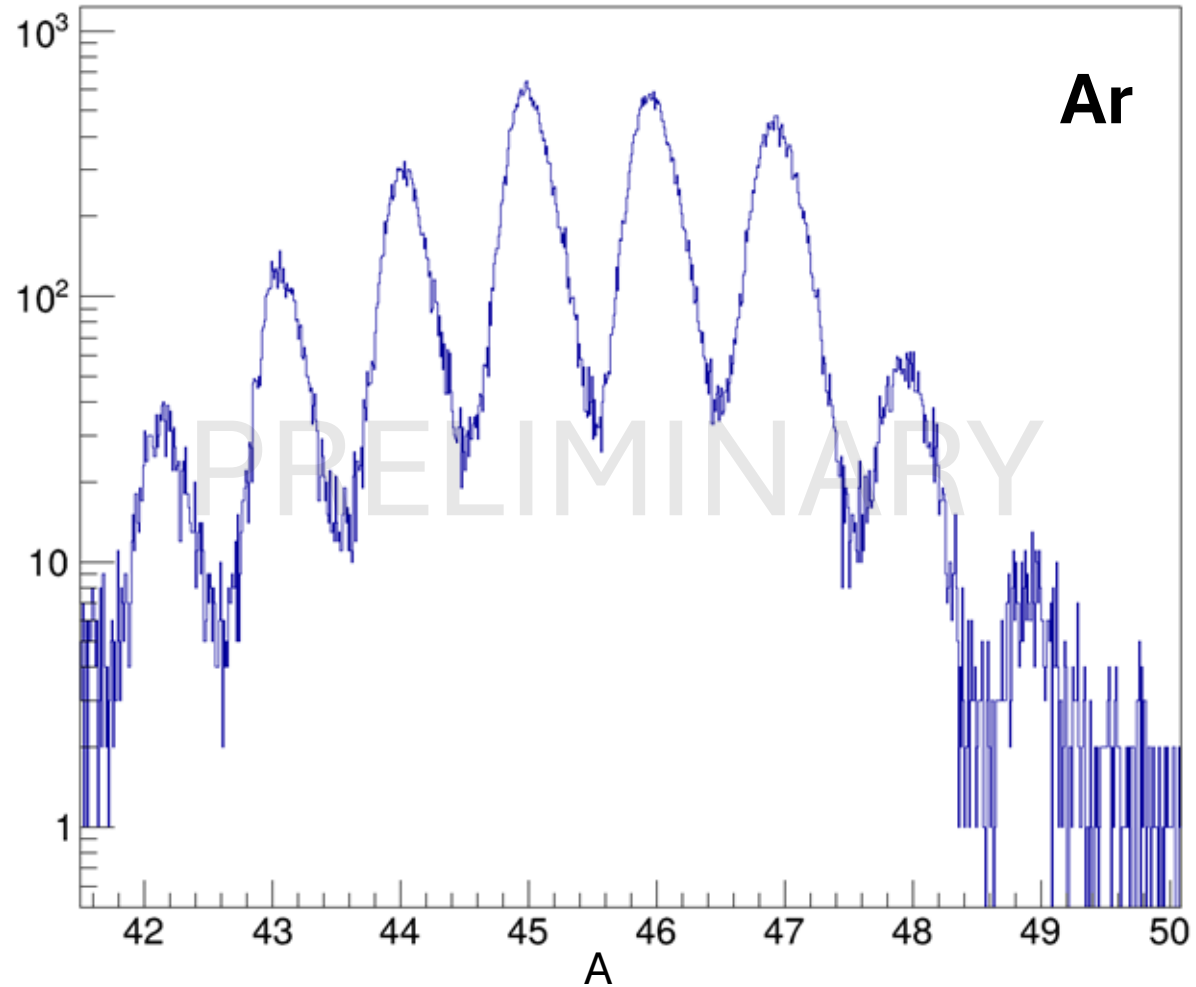

Mass ( $Z = 20$ )

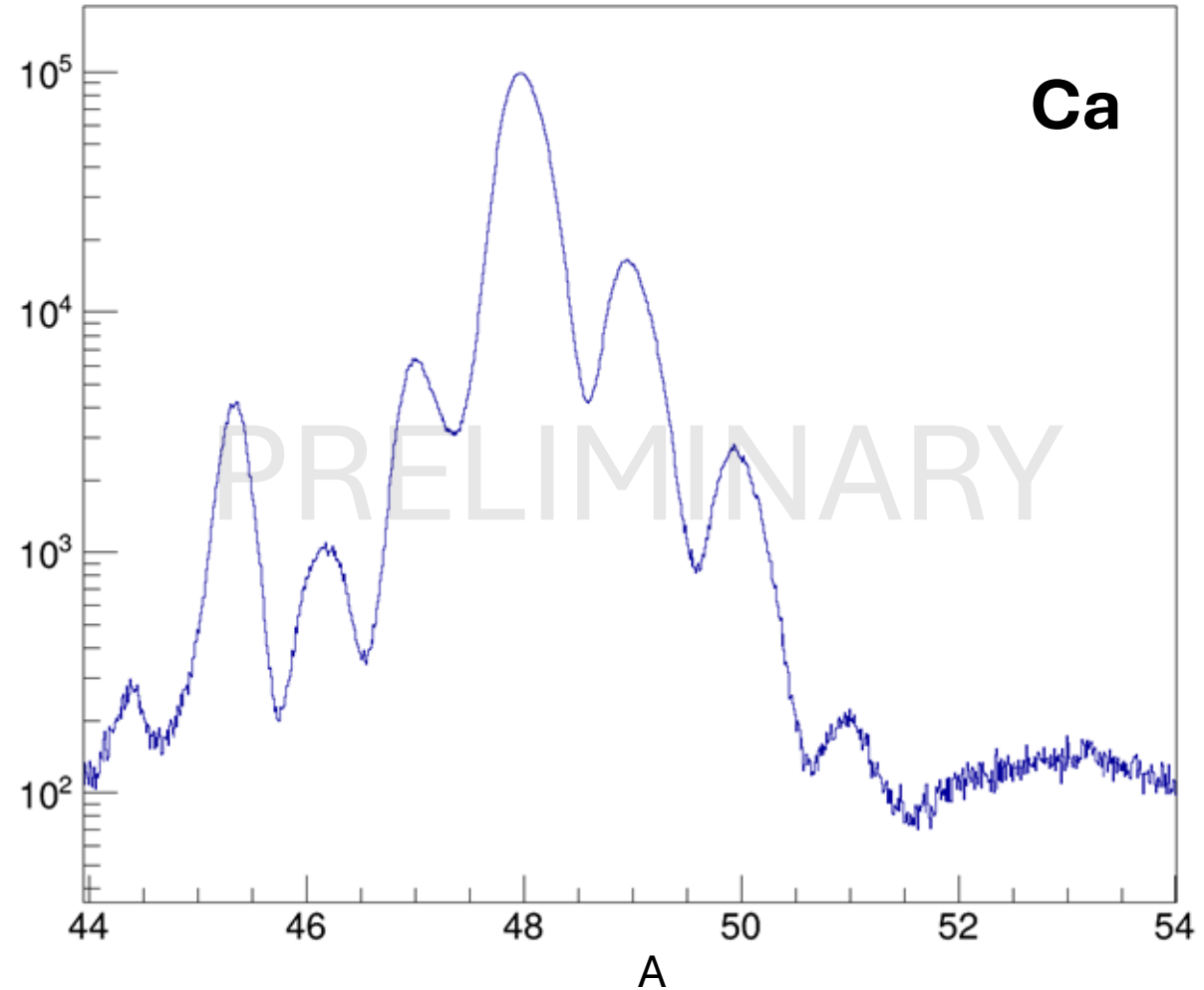

# Preliminary $\gamma$ Spectroscopy



- Preliminary spectroscopy has been performed on the online data by Eleanor Ronning
  - Decays present from Ti, Sc, Ca, K, & Ar were identified & isolated for both DSAM & Plunger
- **Today, we will focus on just Ar & Ca isotopes**



# $^{52}\text{Ca}$ ( $Z = 20, N = 32, J^\pi = 0^+, T_{1/2} = 4.6 \text{ s}$ )

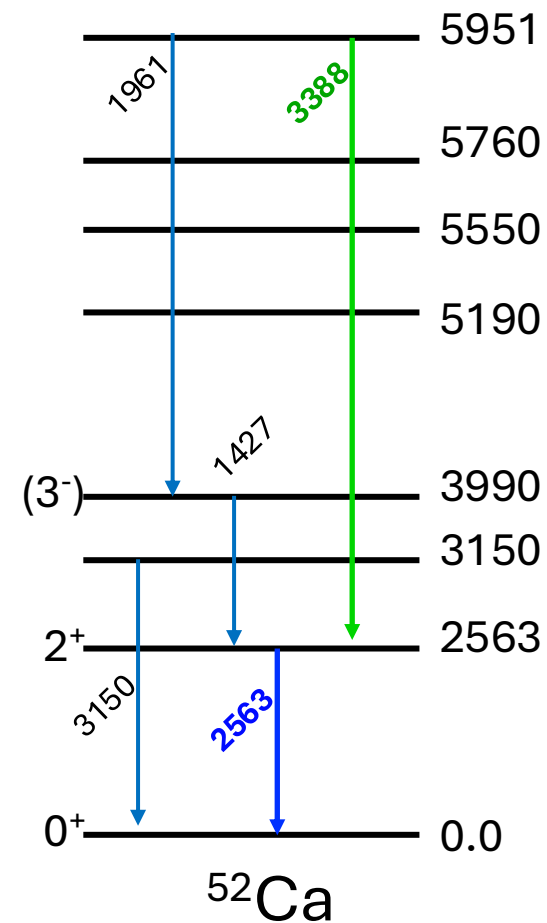
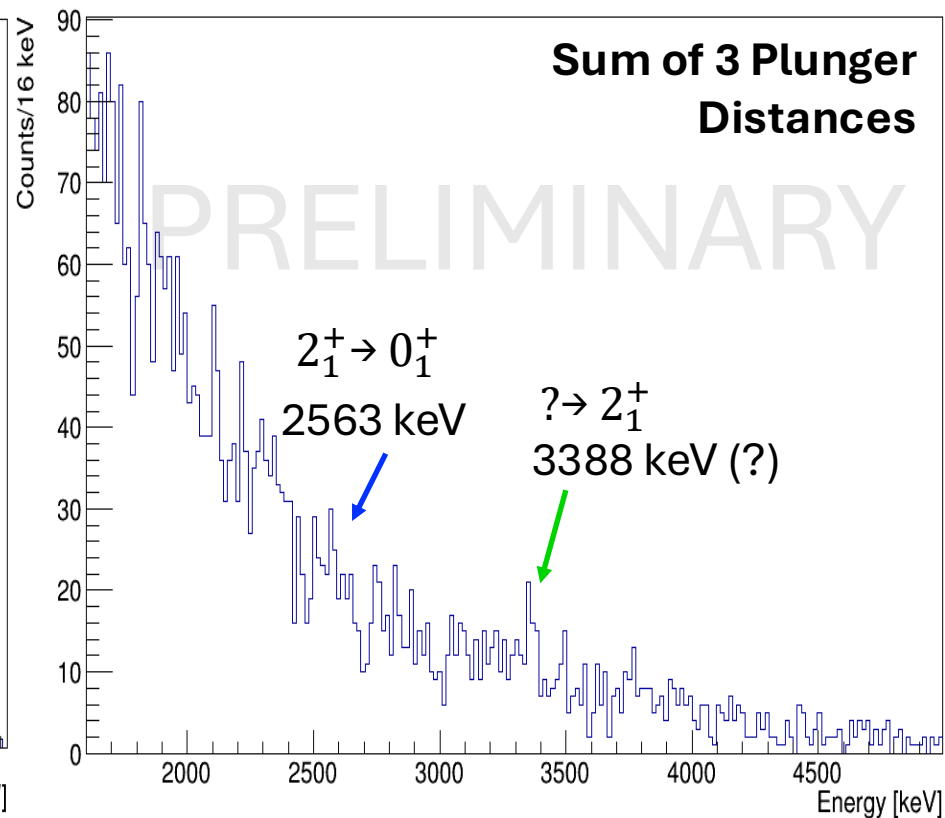
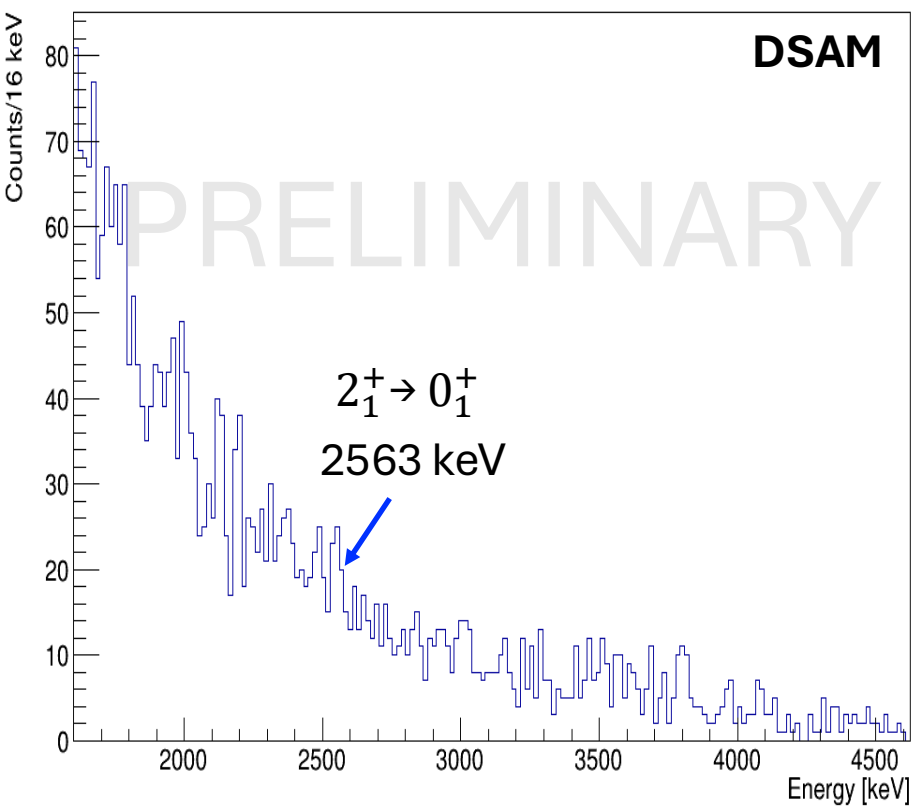

# $^{51}\text{Ca}$ ( $Z = 20, N = 31, J^\pi = 3/2^-, T_{1/2} = 10.0 \text{ s}$ )

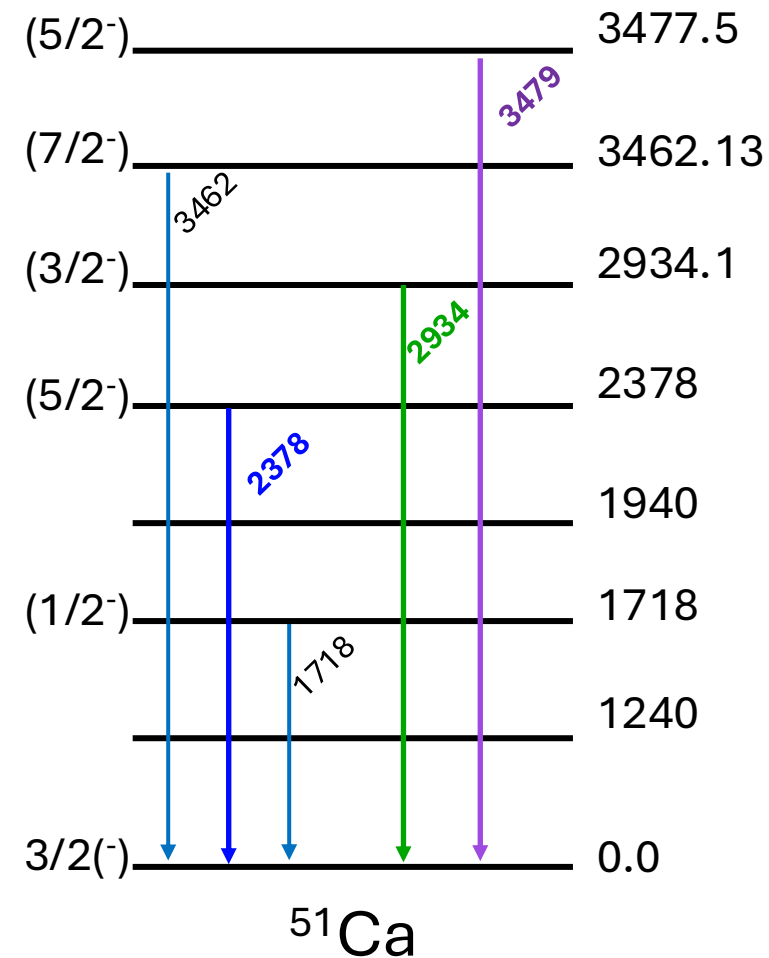
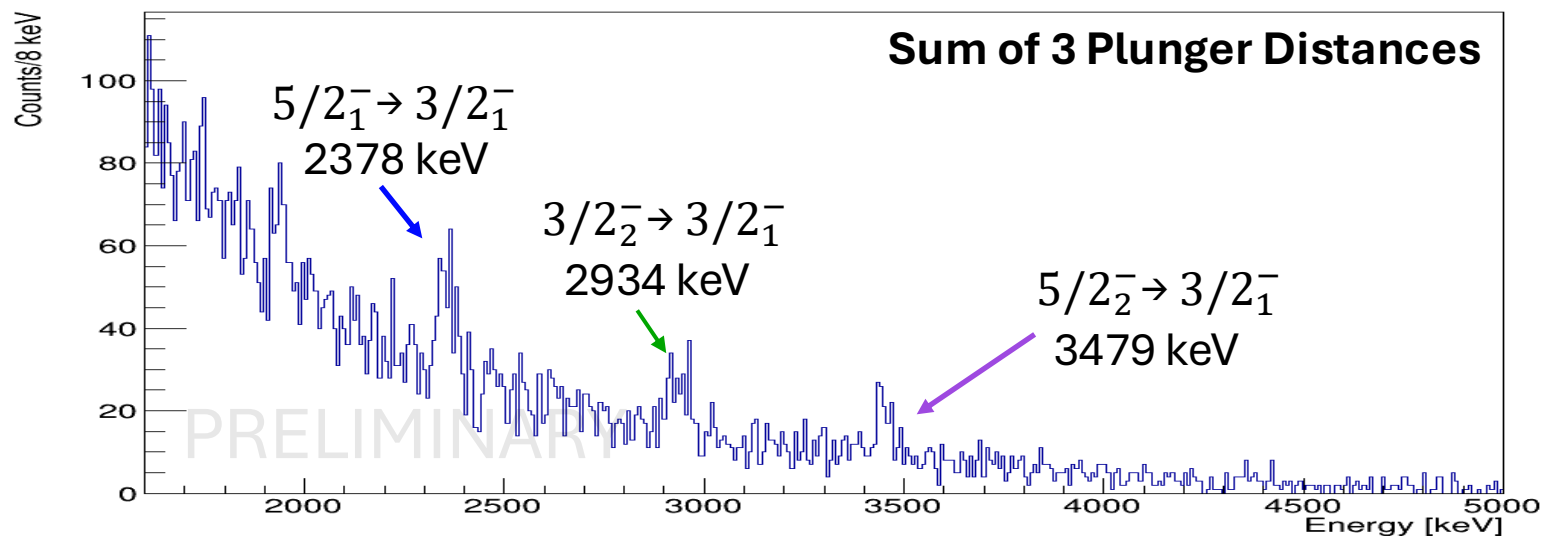
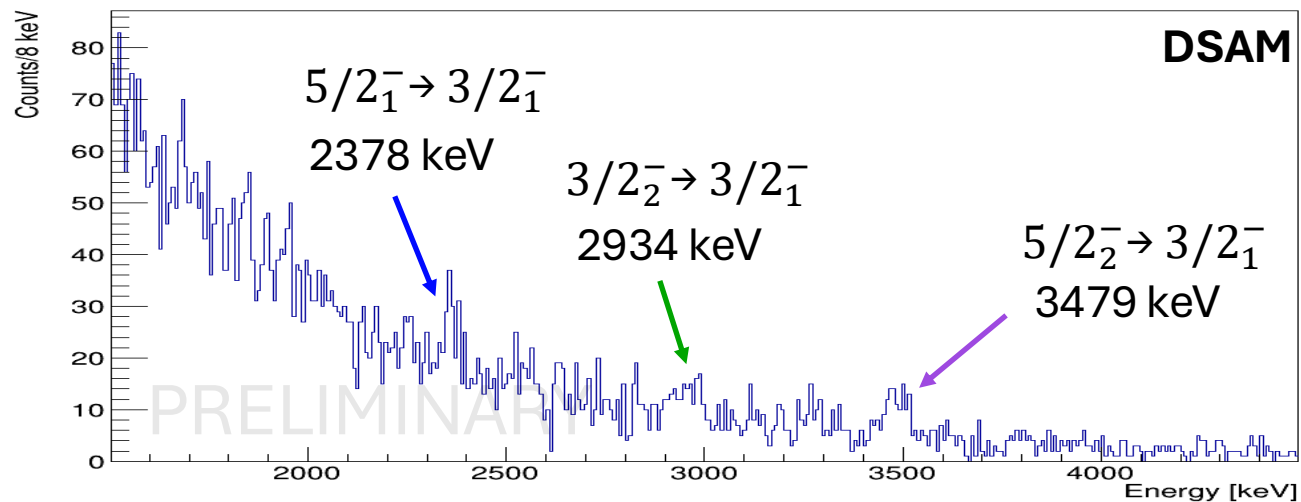

# $^{50}\text{Ca}$ ( $Z = 20, N = 30, J^\pi = 0^+, T_{1/2} = 13.45 \text{ s}$ )

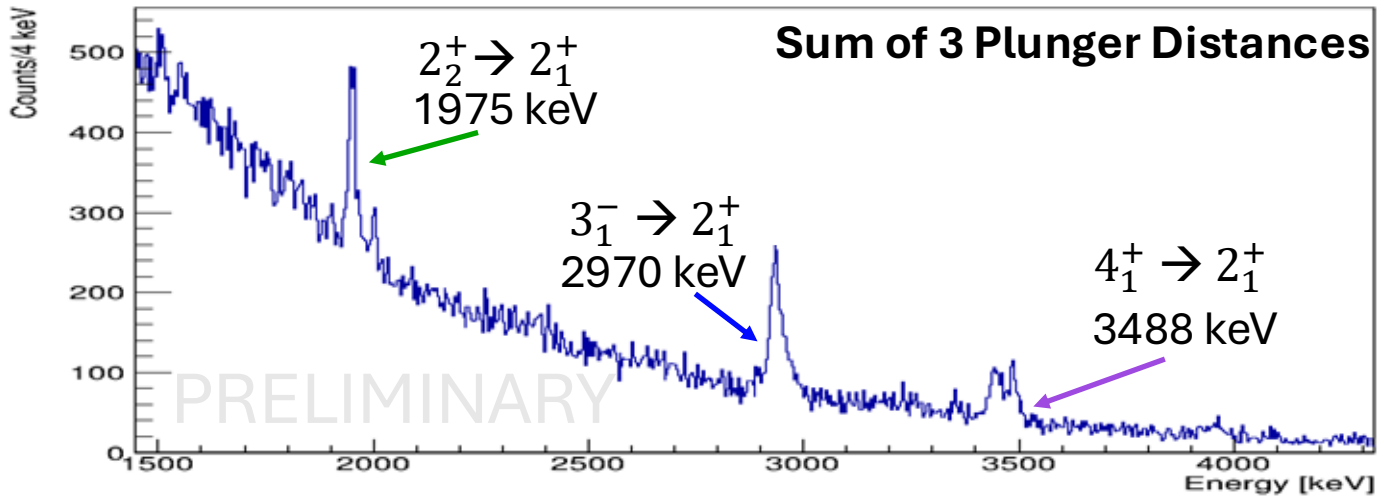
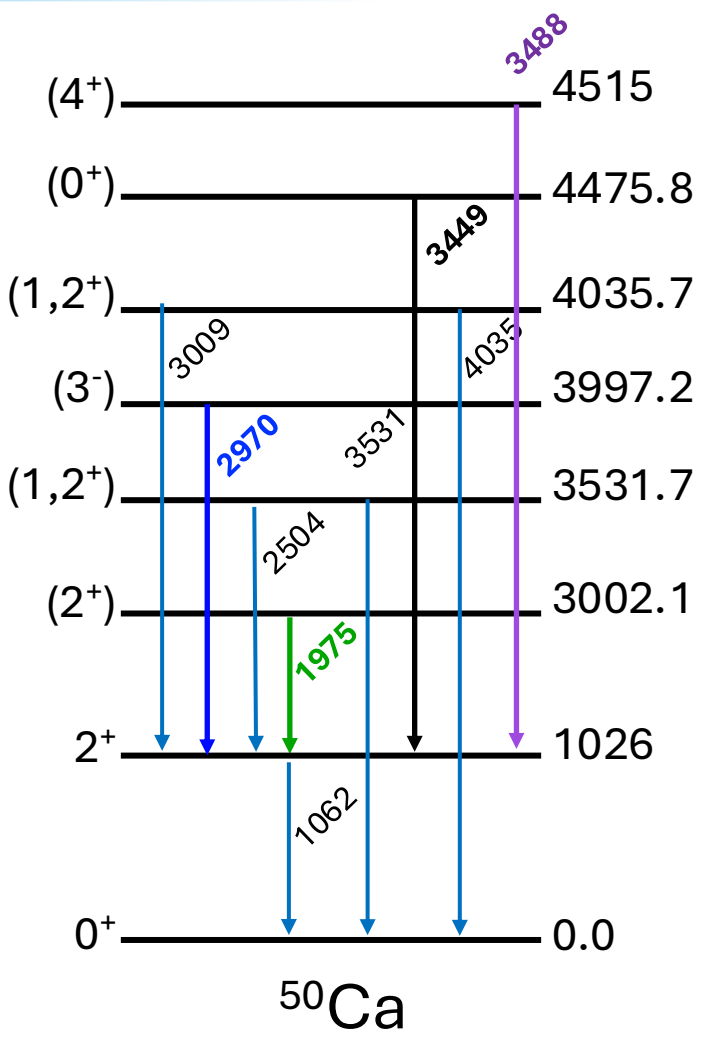
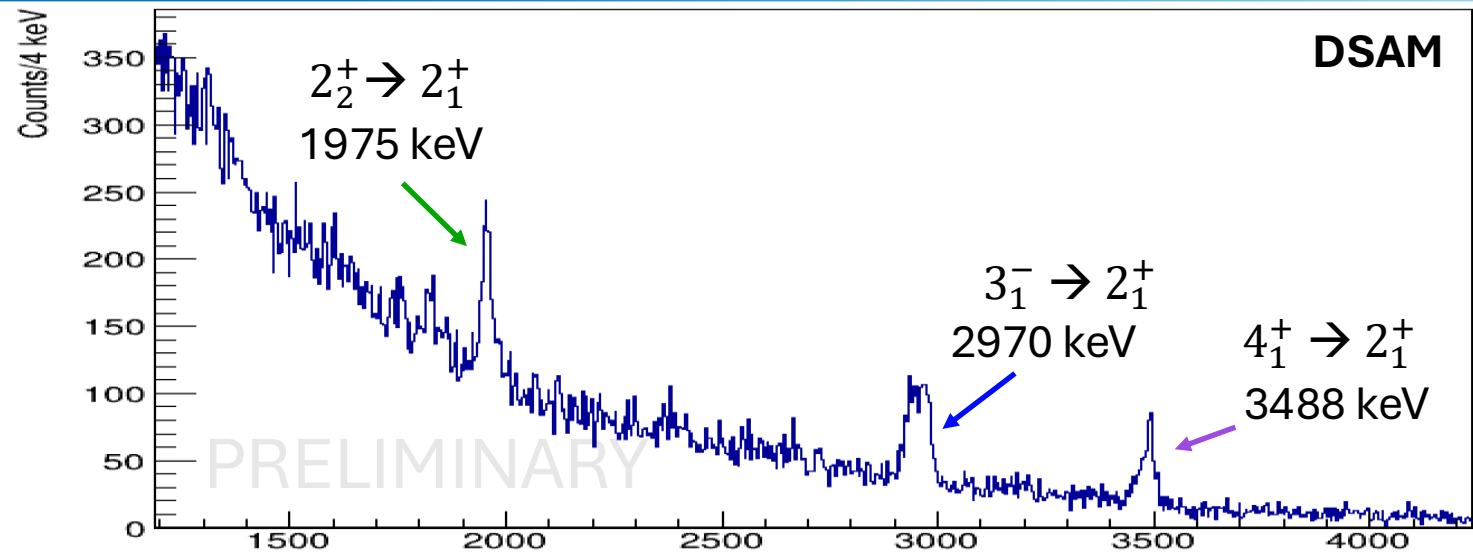

# $^{48}\text{Ar}$ ( $Z = 18, N = 30, J^\pi = 0^+, T_{1/2} = 0.416 \text{ ms}$ )

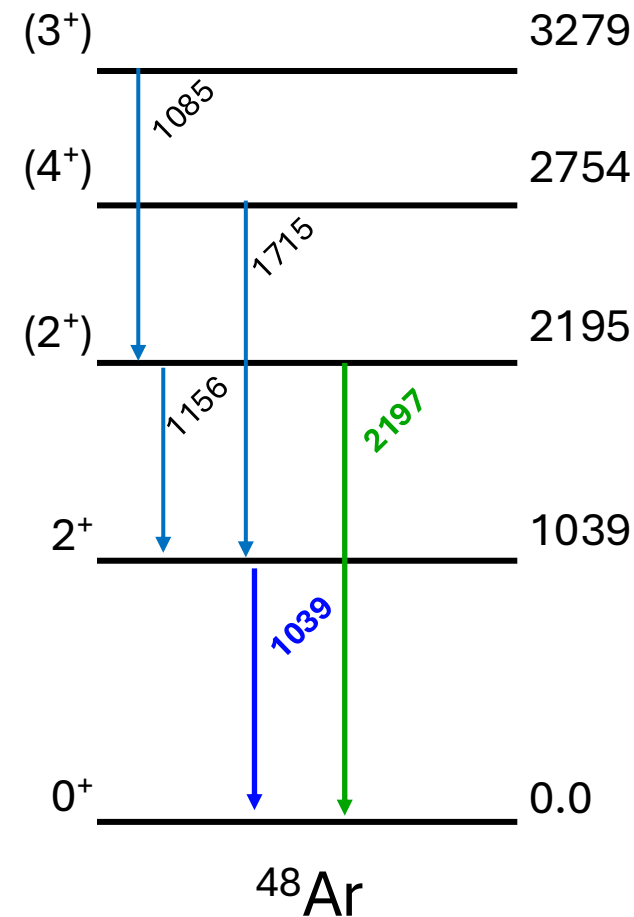
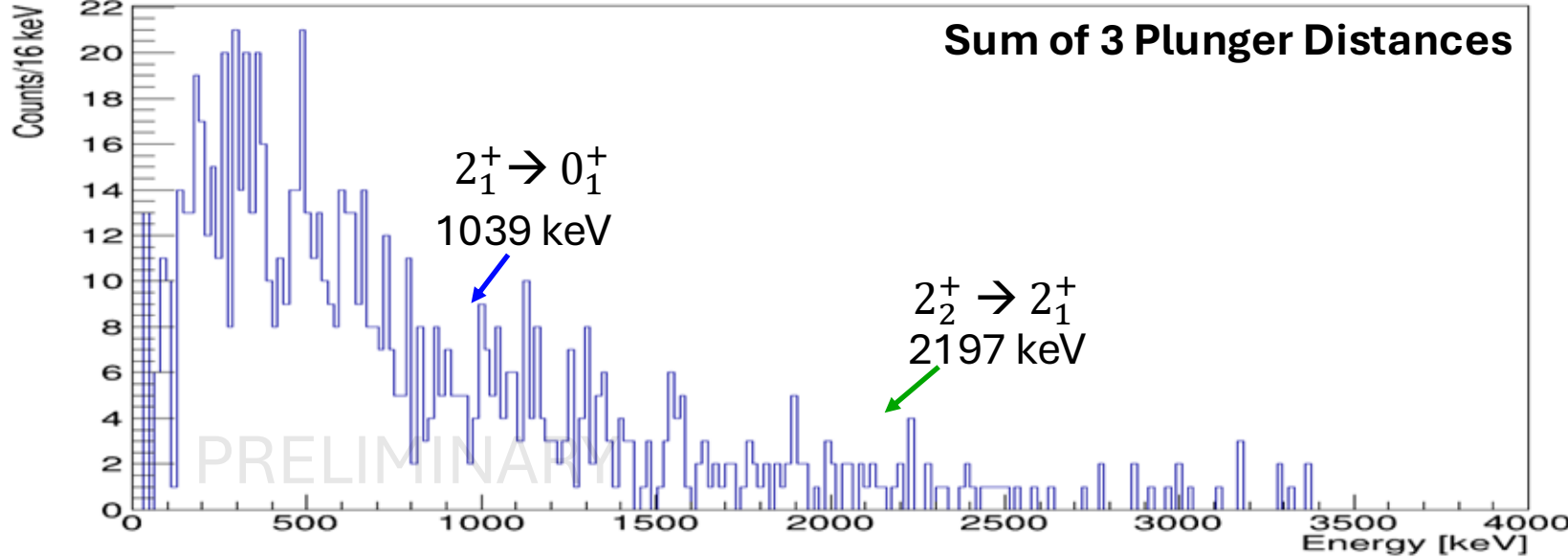
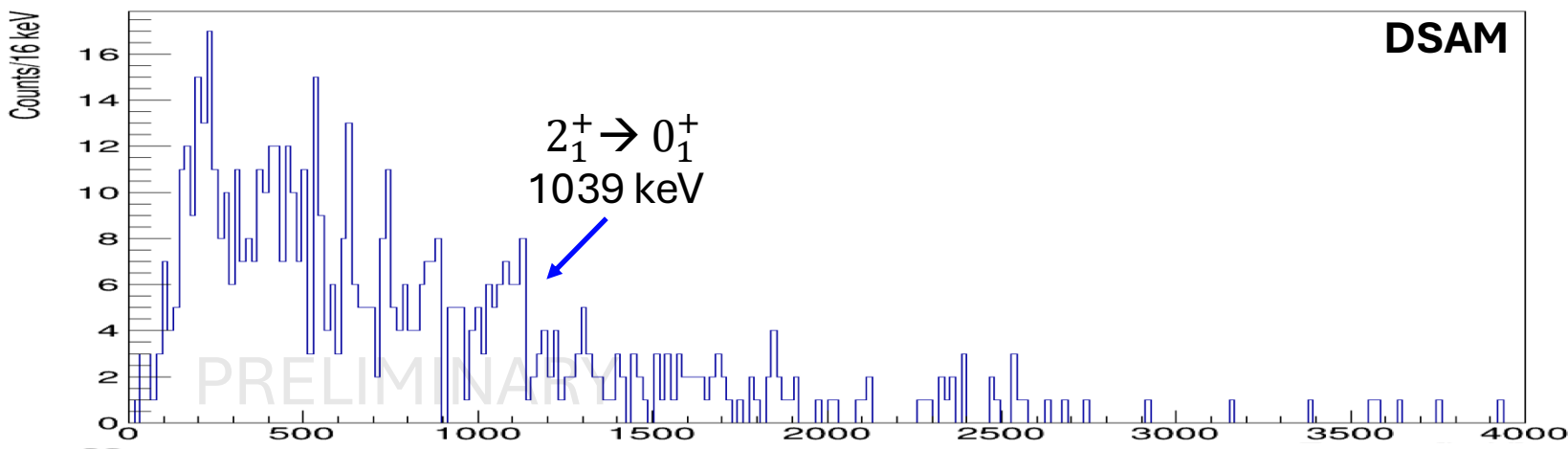

# $^{47}\text{Ar}$ ( $Z = 18, N = 29, J^\pi = 3/2^-, T_{1/2} = 1.23 \text{ s}$ )

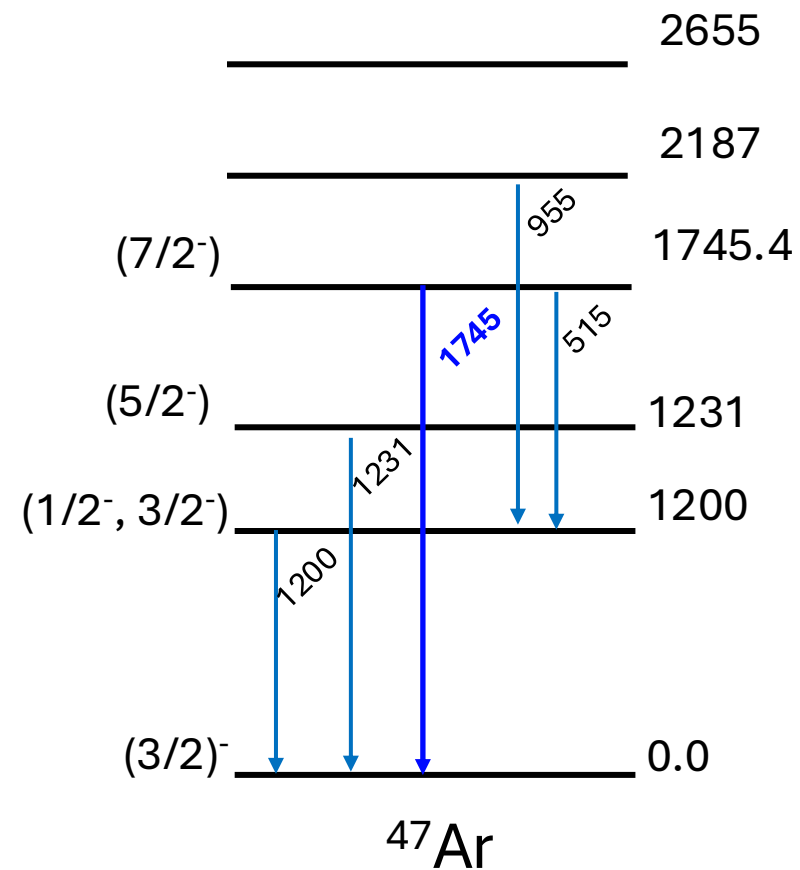
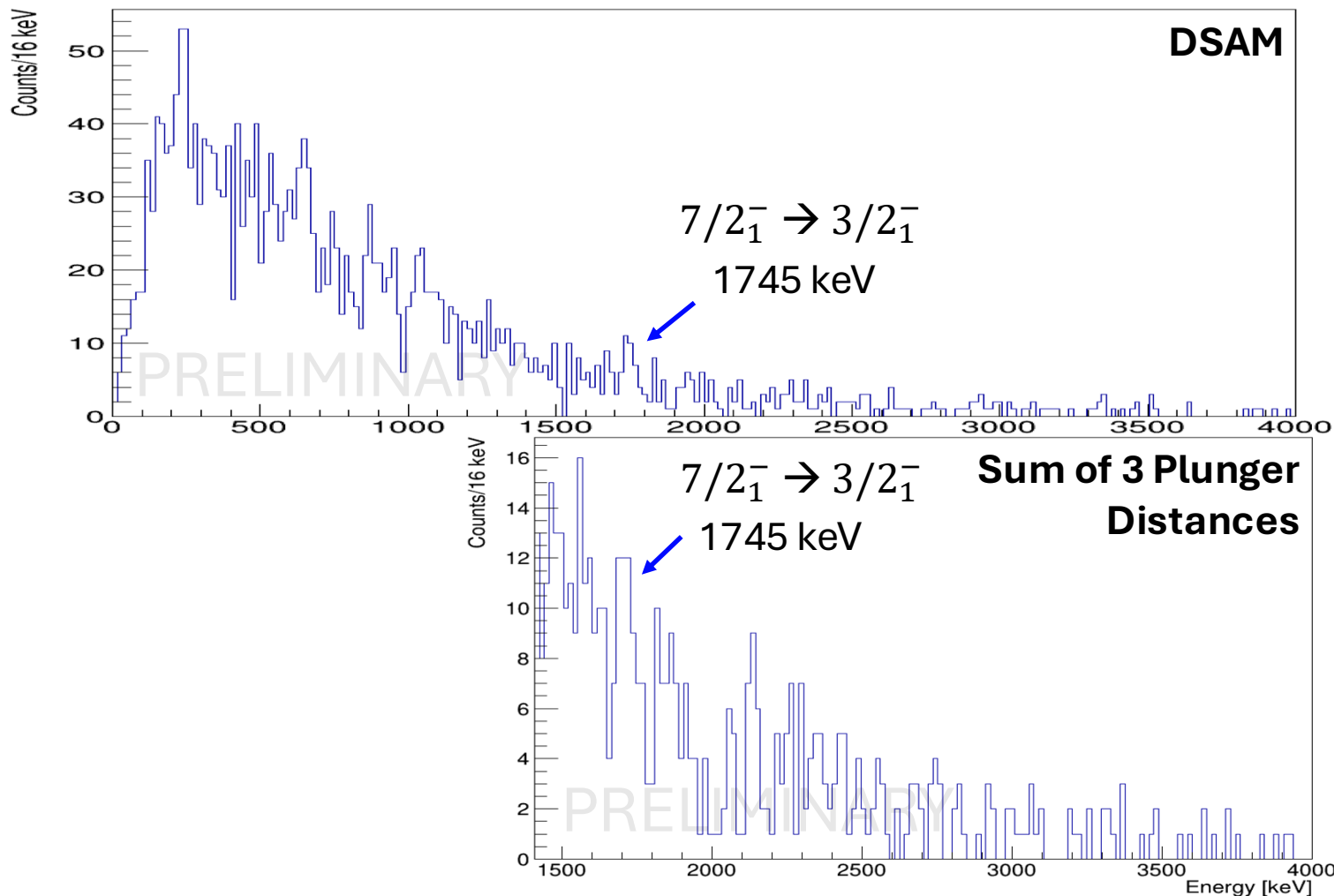

# $^{46}\text{Ar}$ ( $Z = 18, N = 28, J^\pi = 0^+, T_{1/2} = 8.4 \text{ s}$ )

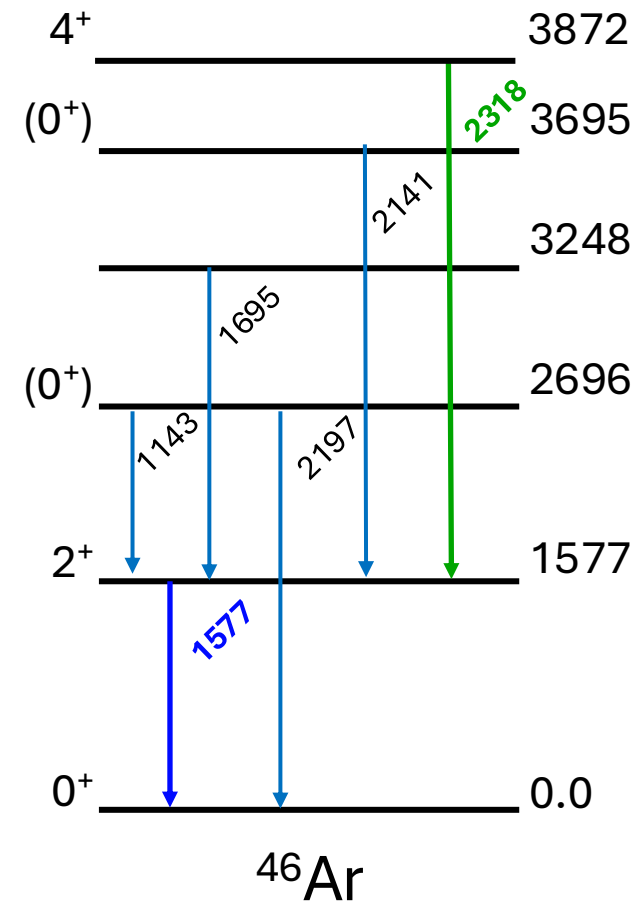
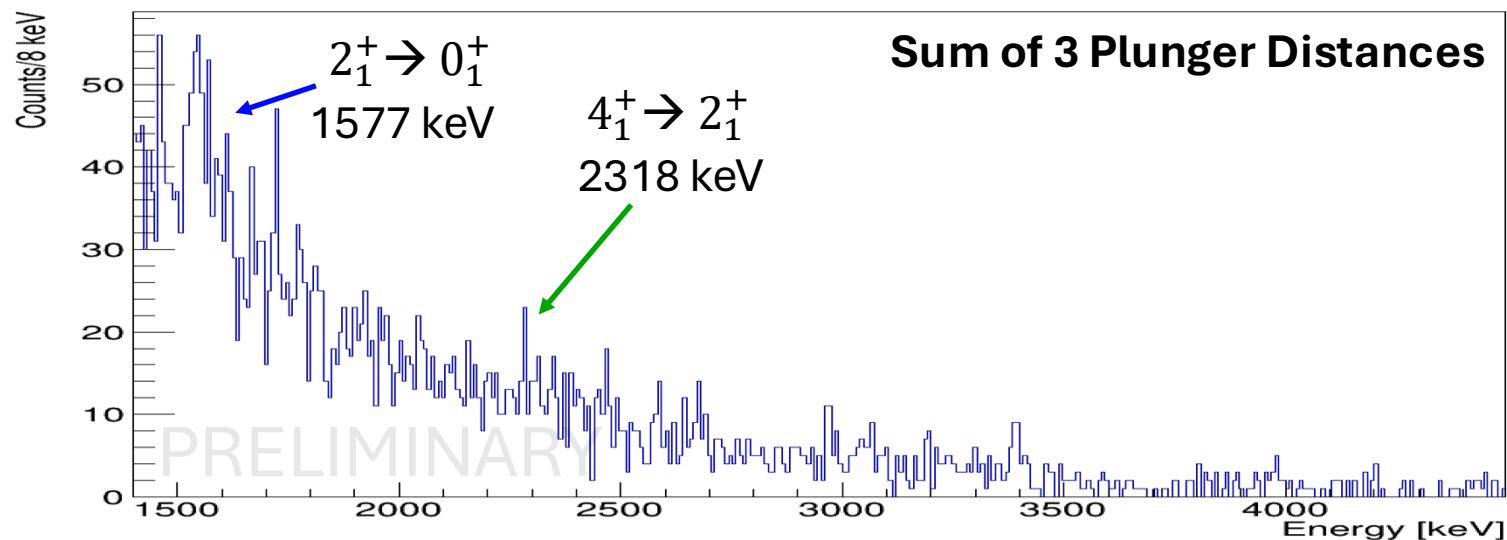
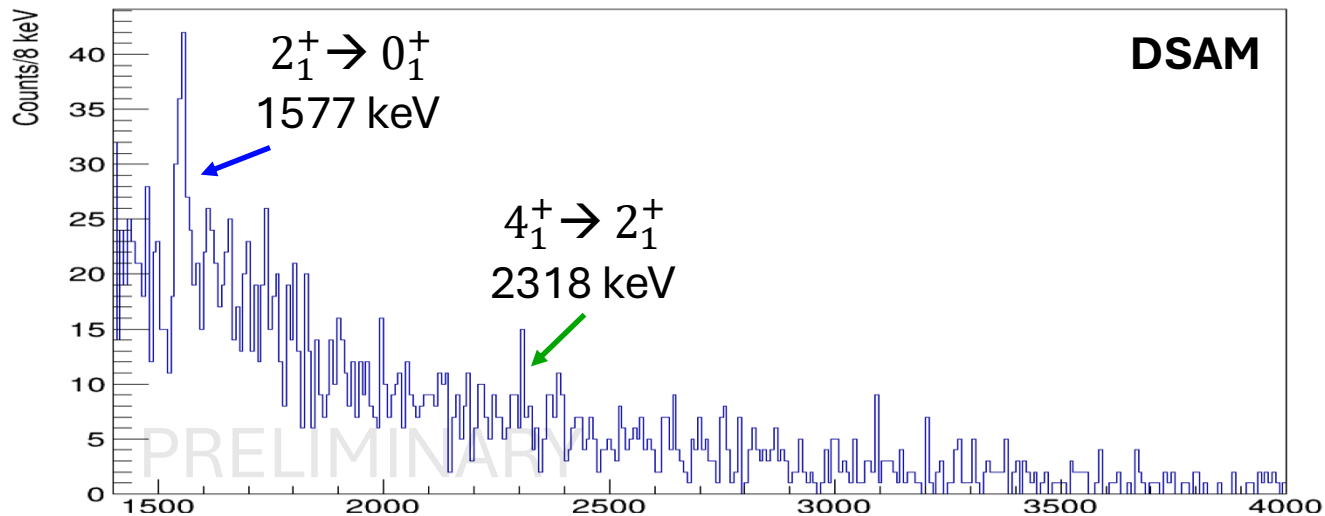

## PRISMA

- Calibrations completed for detector components
- Now optimizing the charge calibration for optimal mass resolution

## AGATA

### $^{50}\text{Ca}$ :

- The  $2_2^+$  level is very short lived (tens of fs)
- The  $3^-$  level is quite short lived (hundreds of fs)
- The  $4^+$  state lives longer (0.5 ps ?)

### $^{51}\text{Ca}$ :

- Only the  $5/2^- \rightarrow 3/2^-$  has a strong shifted component
- The other levels seem longer lived ones.

### $^{52}\text{Ca}$ :

- The  $2^+ \rightarrow 0^+$  does not feature a significant lineshape
- In plunger measurements it is less clear (all shifted ?)

# Summary & Next Steps



## To-do:

### PRISMA

- Complete mass isolation & remove the background contamination, particularly important for  $^{52}\text{Ca}$  spectroscopy
- Refine  $\beta$  from reconstructed path length & time-of-flight for Doppler correction

### AGATA

- Apply new PRISMA mass isolation to the recalibrated & ND corrected data
- Investigate lifetimes in  $^{46-48}\text{Ar}$  &  $^{50-52}\text{Ca}$  with RDDS & DSAM
- Further investigations into the measurements available in Ti, Sc, K, Cl, & S



## Thank you for listening

**INFN-LNL:** **Andrea Gottardo, Giuseppe Andreatta,** Daniele Brugnara, Lorenzo Corradi, Alain Goasduff, Enrico Fioretto, Benito Gongora Servin, Andrea Gozzelino, Elia Pilotto, Alberto Stefanini, Damiano Stramaccioni, Irene Zanon

**INFN-PD:** **Eleanor Ronning, Daniele Mengoni,** Pablo Aguilera, Dino Bazzacco, Franco Galtarossa, Giovanna Montagnoli, Raquel Nicolás del Álamo, Sara Pigliapoco, Julgen Pellumaj, Marta Polettini, Kseniia Rezyunkina,

**Universitat de Valencia:** **Jose Javier Valiente-Dóbon**

**Institut für Kernphysik:** **Christoph Fransen,** Rainer Abels, Arwin Esmaylzadeh, Herbert Hess, Richard Novak, Peter Reiter, Franziskus von Spee

**INFN Milano:** Giovanna Benzoni, Simone Bottoni,

**Slovak Academy of Sciences:** Matus Balogh, Monika Birova, Matus Sedlak, Margareta Sigmund,

**GSI:** Filippo Angelini

**CSIC:** Rosa Pérez

**Institut Ruđer Bošković:** Mirco Del Fabbro, Suzana Szilner

**INFN Firenze:** Marco Rocchini

**IN2P3:** Luca Zago



UNIVERSITÀ  
DEGLI STUDI  
DI PADOVA



UNIVERSITY  
OF COLOGNE

