

# Fermi Large Area Telescope



S. Maldera  
INFN - Torino



# Fermi Gamma-Ray space telescope

- Il Fermi Gamma-Ray Space Telescope e' una missione internazionale per l'esplorazione del cielo gamma per mezzo di due strumenti:
  - Gamma-ray Burst Monitor (GBM): 8 keV - 40 MeV
  - Large Area Telescope (LAT): 100 MeV - ~500GeV

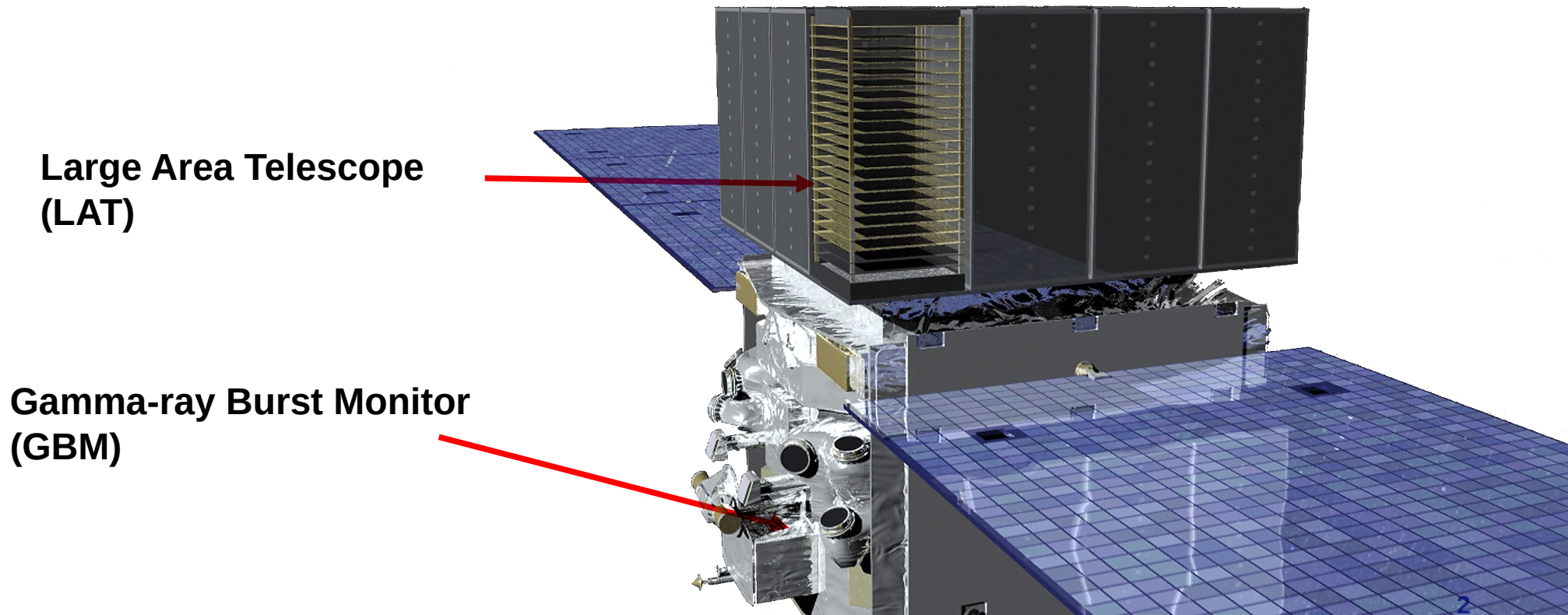

Large Area Telescope  
(LAT)

Gamma-ray Burst Monitor  
(GBM)

# 17 anni fa...

## Lancio

GLAST (Gamma Large Area Space Telescope), lanciato da un razzo Delta II da Cape Canaveral l'11 Giugno 2008 alle 12:05 EDT.

Rinominato in onore di Enrico Fermi dopo il lancio

- Orbita quasi circolare
- Altitudine: 565 km
- Inclinazione: 25.6 deg
- Periodo orbitale= ~90 minuti

# Rivelazione fotoni gamma

## Interazioni fotoni-materia

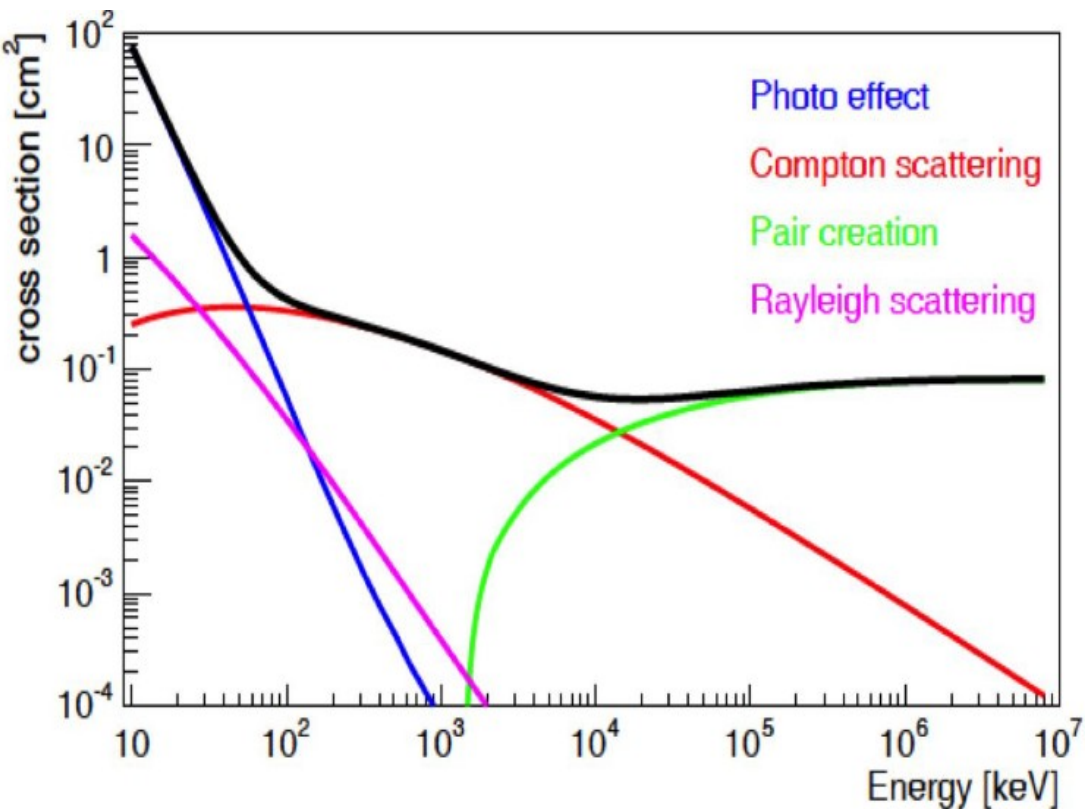

## Effetto Fotoelettrico

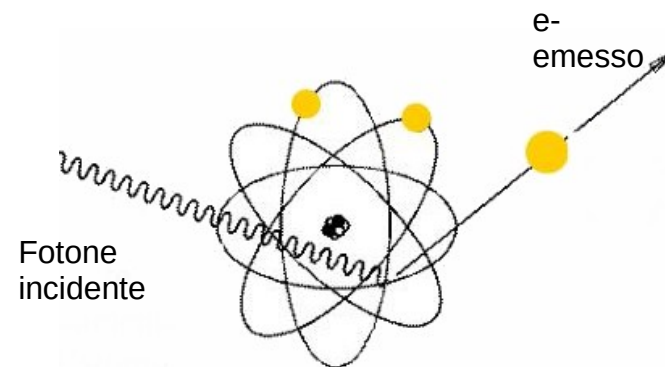

## Scattering Compton

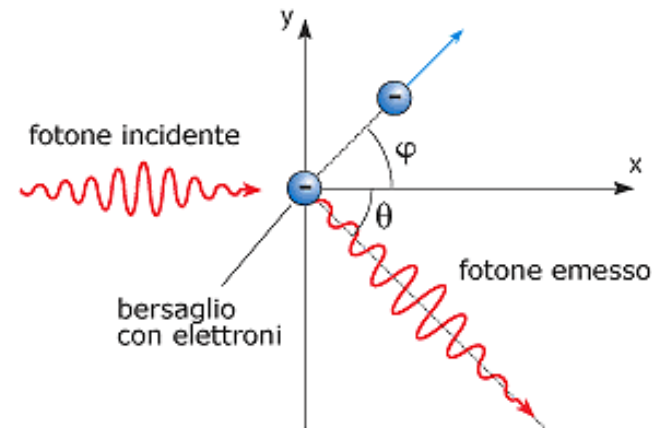

## Produzione di coppie

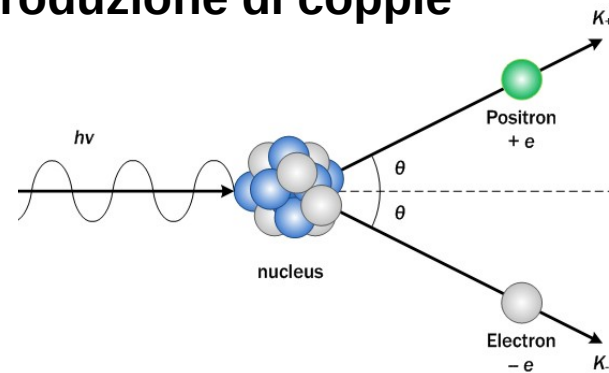

# Rivelazione fotoni gamma

## Interazioni fotoni-materia

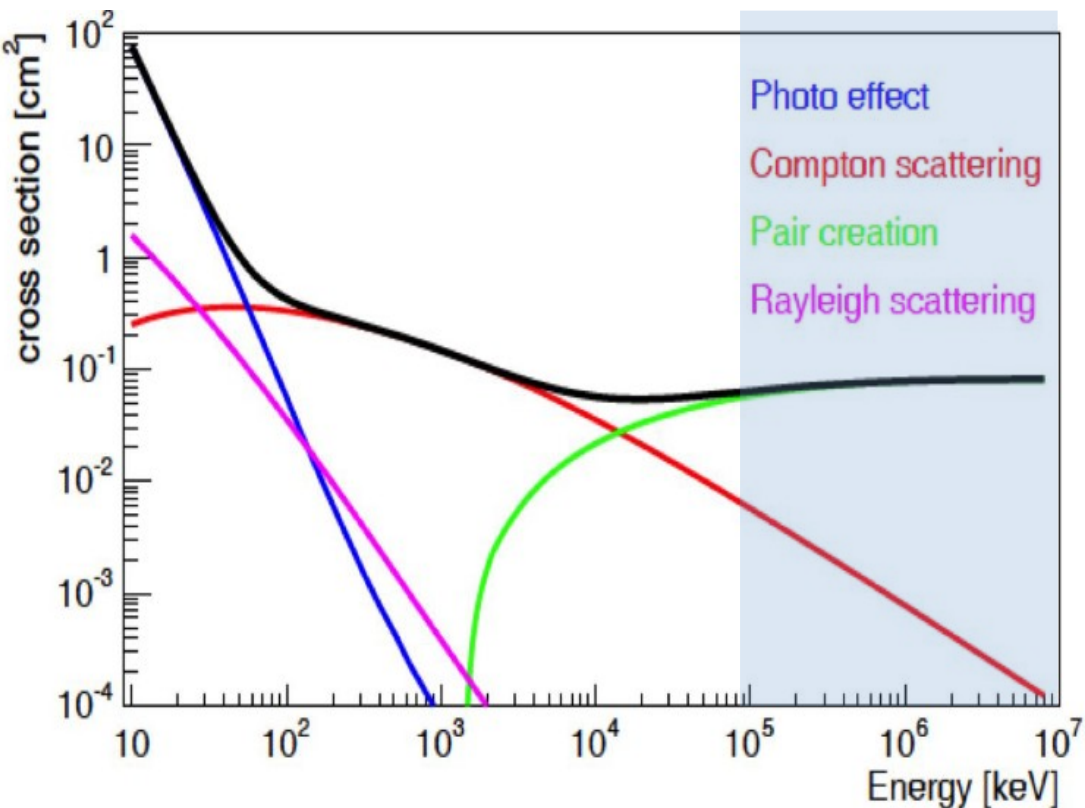

La produzione di coppie e' il processo dominante per fotoni alle energie di interesse del LAT

La coppia e<sup>+</sup> e<sup>-</sup> fornisce indicazioni riguardo a energia e direzione di arrivo del fotone

## Produzione di coppie

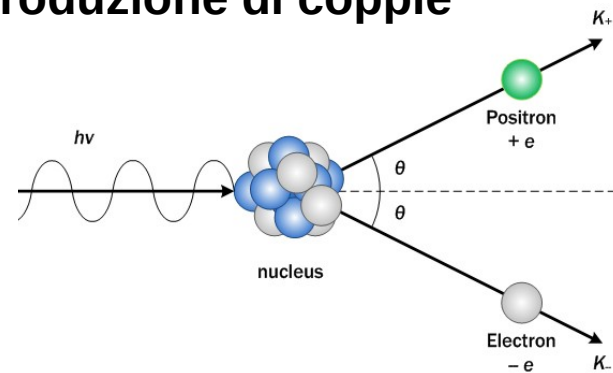

# Pair production Telescope

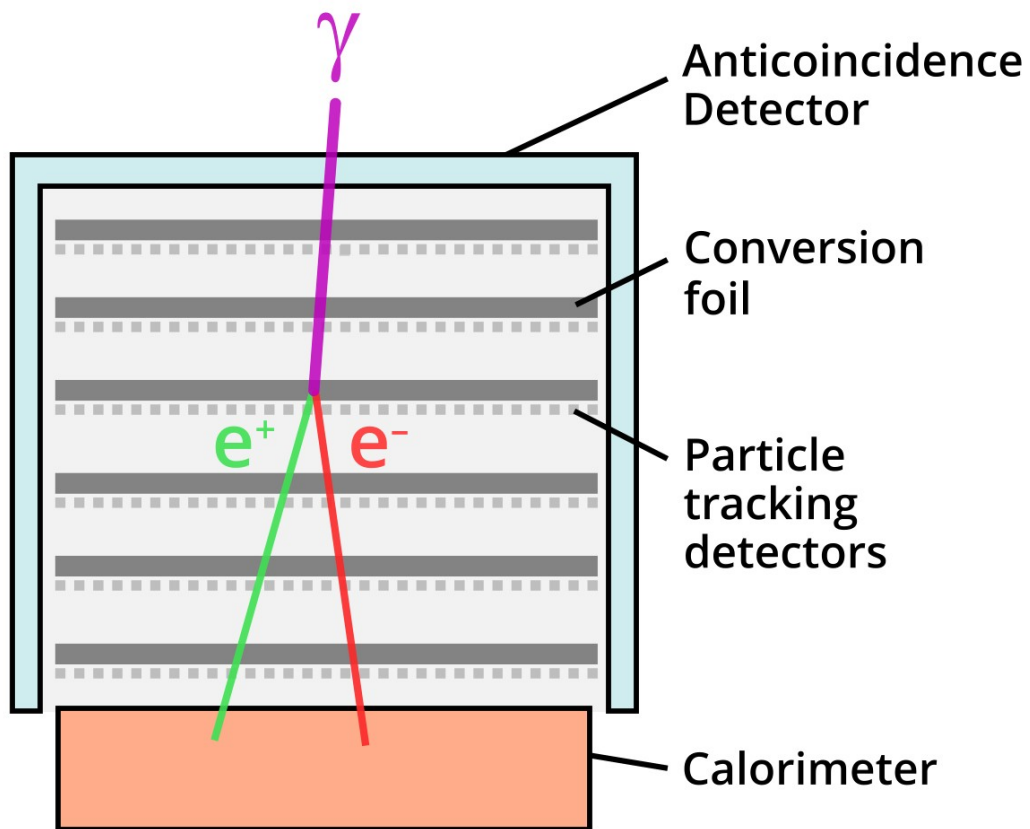

- Convertitore: materiale a alto Z per aumentare la probabilita' di produzione di coppie
- Tracciatore: Rivelatore che traccia il passaggio della coppia  $e^+e^-$
- Calorimetro: Misura l'energia della coppia  $e^+e^-$
- Anticoincidenza: Permette di distinguere le particelle cariche che entrano nel rivelatore

# Large Area Telescope

## Fermi-LAT

Modular design with 3 subsystems. Calorimeter and Tracker organized in 4 modules

## Public Data Release:

All  $\gamma$ -ray data made public within 24 hours (usually less)

## Anti-Coincidence Detector:

Charged particle separation

## Si-Strip Tracker:

convert  $\gamma \rightarrow e+e^-$   
reconstruct  $g$  direction  
EM v. hadron separation

## Hodoscopic CsI Calorimeter:

measure  $\gamma$  energy  
Image EM shower  
EM v. hadron separation

## Trigger and Filter:

Reduce data rate from  
 $\sim 10\text{kHz}$  to 300 - 500 Hz

## Sky Survey:

With 2.5 sr Field-of-View LAT  
sees the sky every 3 hours

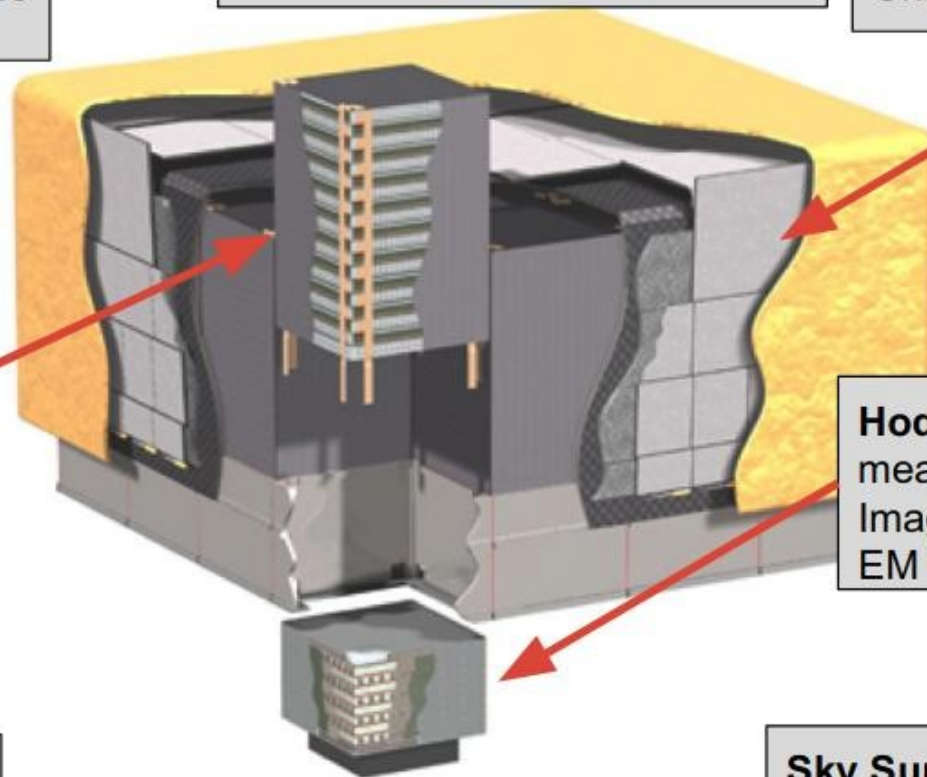

# LAT Tracker



18 bi-layers di silicon strip detector  
(piani x,y)

Intervallati 14 da fogli di tungsteno

spaziatura  $256 \mu\text{m}$

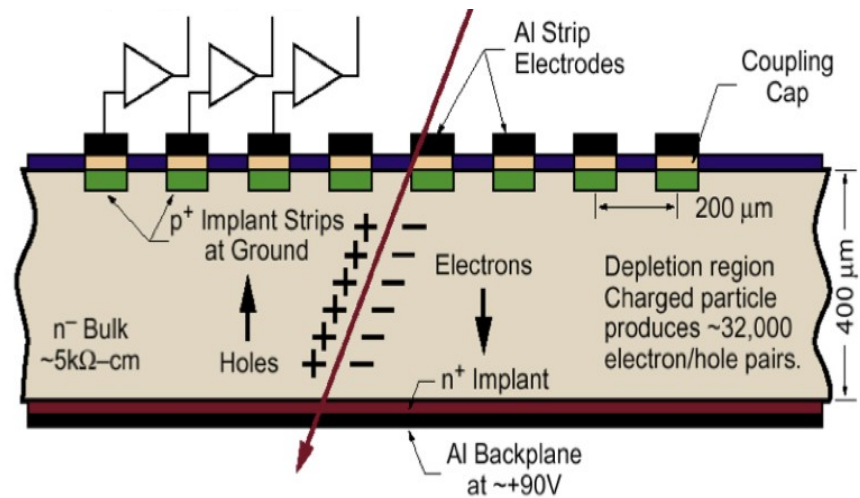
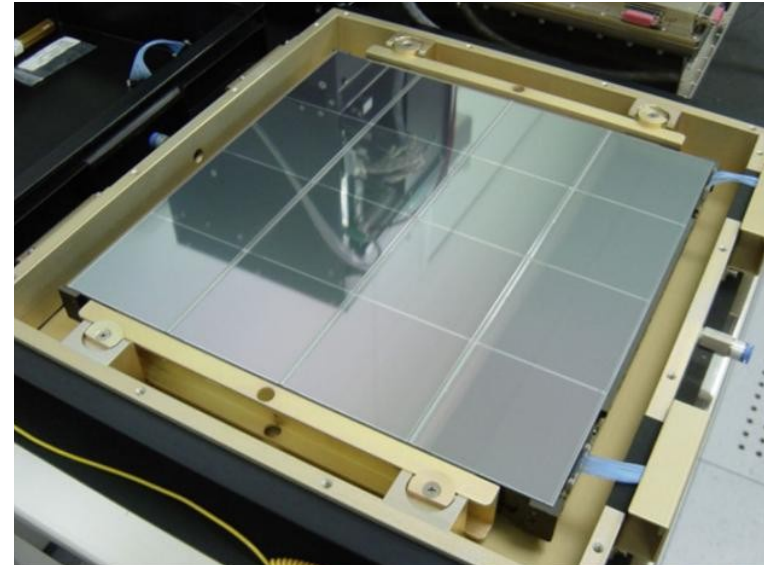

GLAST has 884736 channels. Total Tracker Power = 160 Watts!

# LAT Calorimeter

## Misura l'energia della coppia $e^- e^+$

- Ogni modulo e' formato da 8 strati di 12 cristalli CsI ortogonali tra loro
- Particelle cariche relativistiche producono una luce di scintillazione, raccolta alle estremità tramite 2 fotodiodi

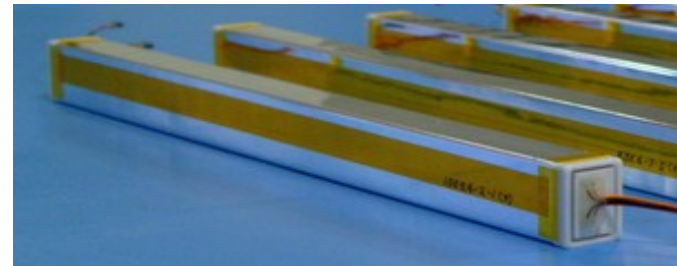
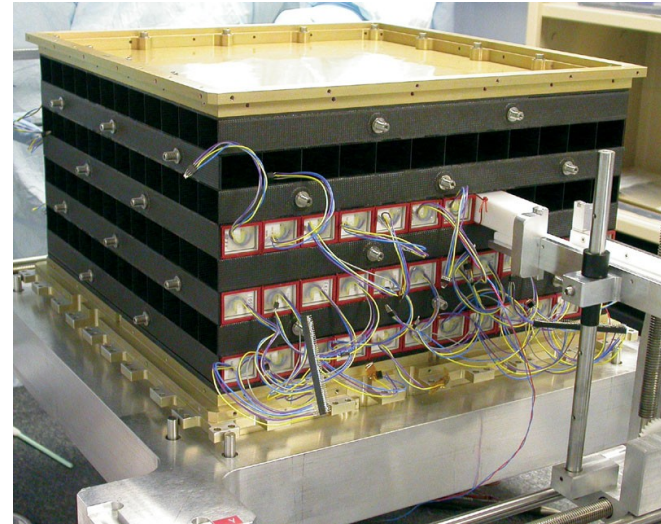

# LAT Calorimeter

## Misura l'energia della coppia $e^- e^+$

- Ogni modulo e' formato da 8 strati di 12 cristalli CsI ortogonali tra loro
- Particelle cariche relativistiche producono una luce di scintillazione, raccolta alle estremità tramite 2 fotodiodi

## Elettroni (e positroni) generano uno sciame elettromagnetico nel calorimetro

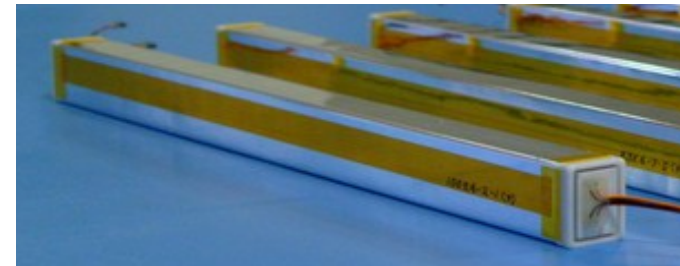
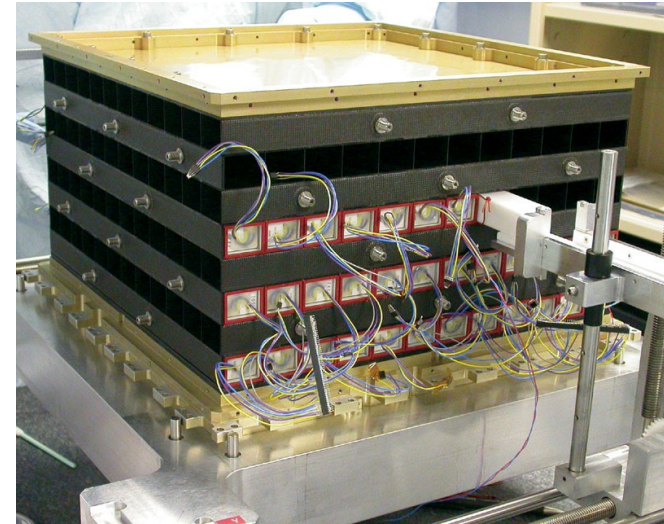
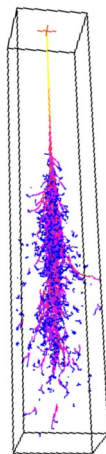
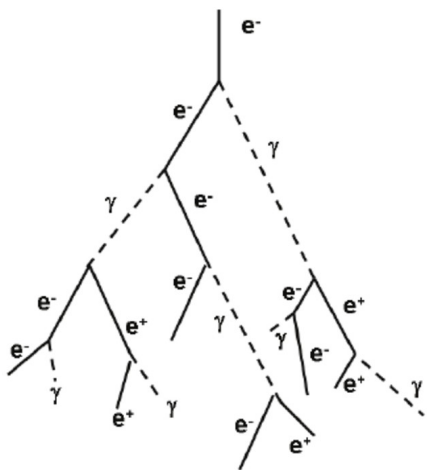

La segmentazione del calorimetro permette di misurare avere un'immagine dello sciame e.m.

# LAT Anticoincidence Detector (ACD)

**Identifica particelle cariche che entrano nel rivelatore**

- Le 16 torri (tracker+cal) sono circondate da 89 piastrelle di scintillatore plastico
- Luce raccolta tramite fibre ottiche e portata a 2 fotomoltiplicatori

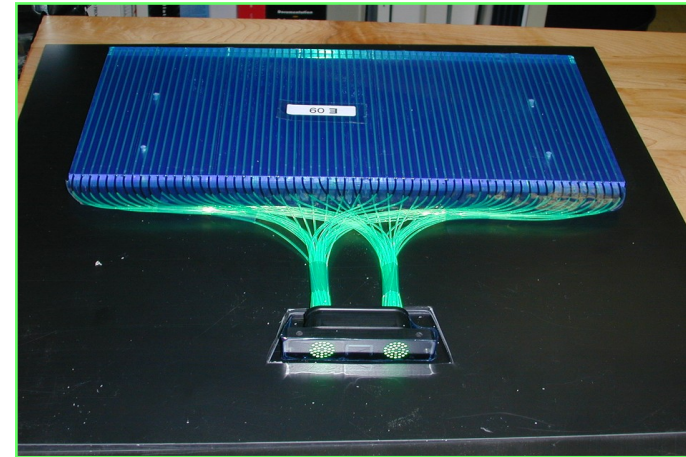

**Segmentazione riduce il self-veto (backsplash dal calorimetro)**

**Alta efficienza (~99.97%)**

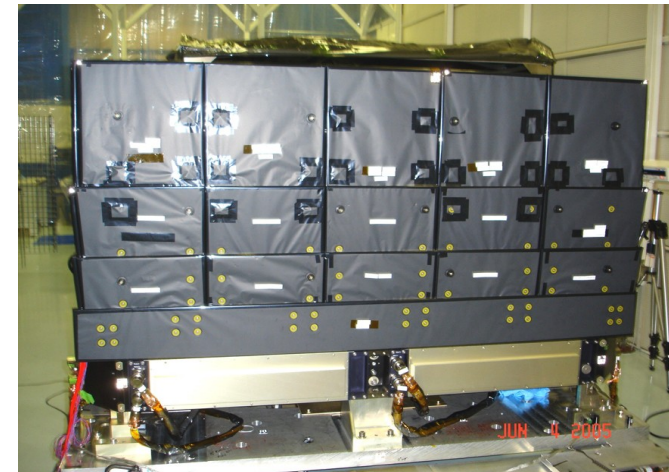

# Fermi pronto per il lancio...

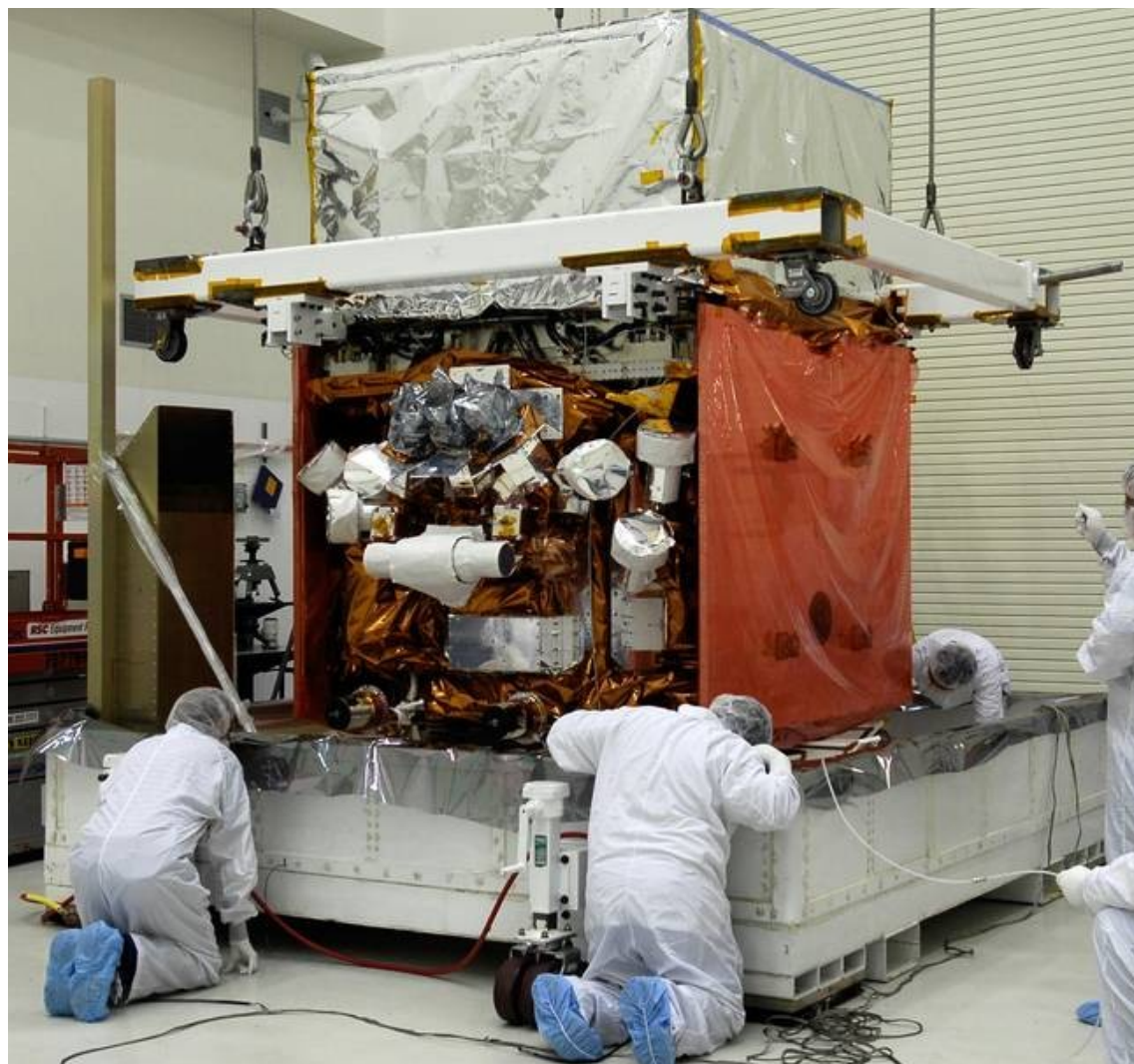
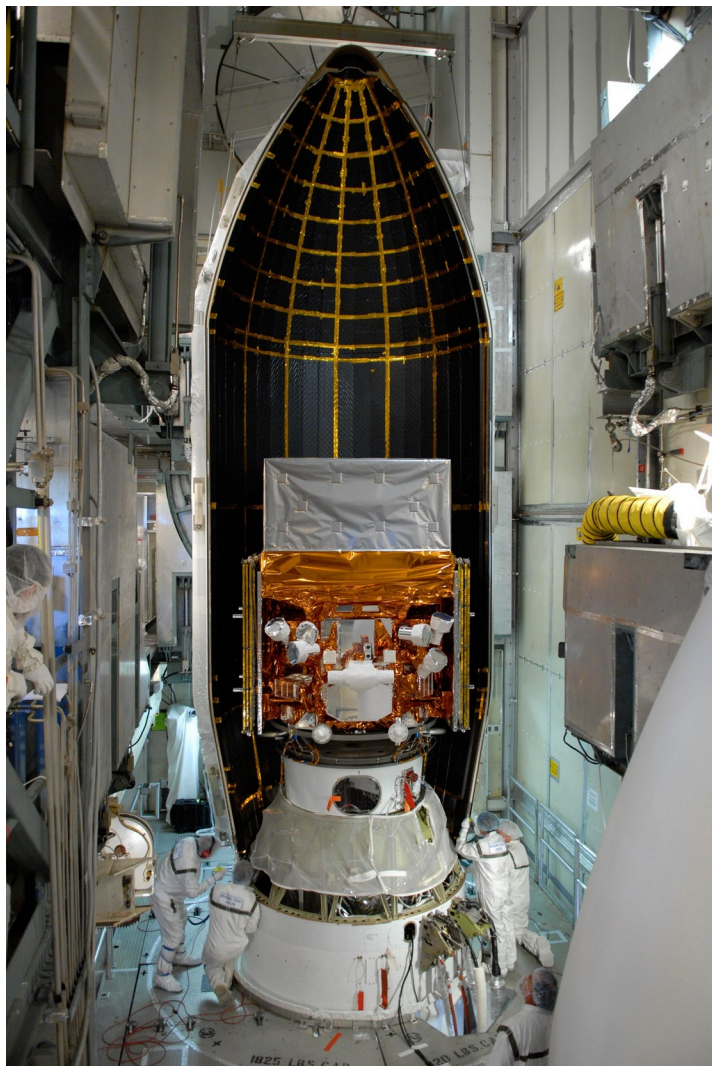

# Ricostruzione degli eventi

**A partire dai segnali nei rivelatori vogliamo:**

- eliminare (o studiare) le particelle cariche (background)
- ricostruire la direzione di arrivo
- ricostruire l'energia

# Fotone gamma nel LAT

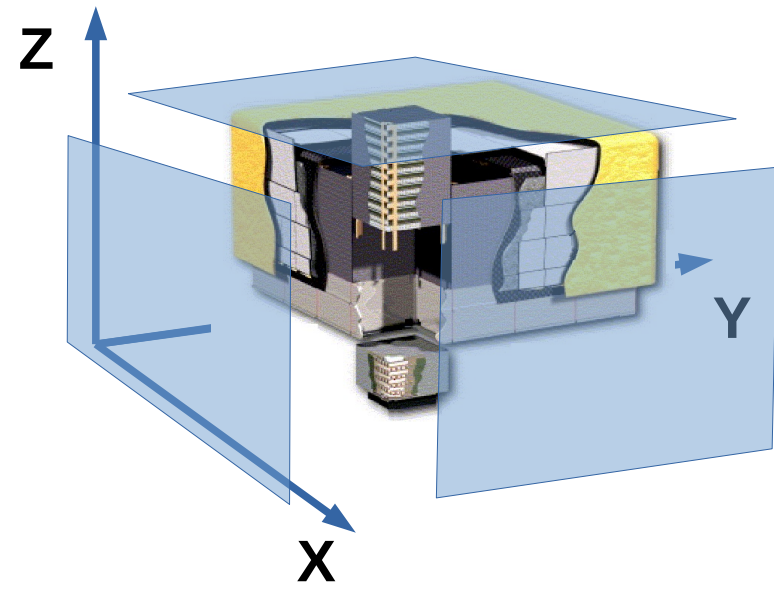
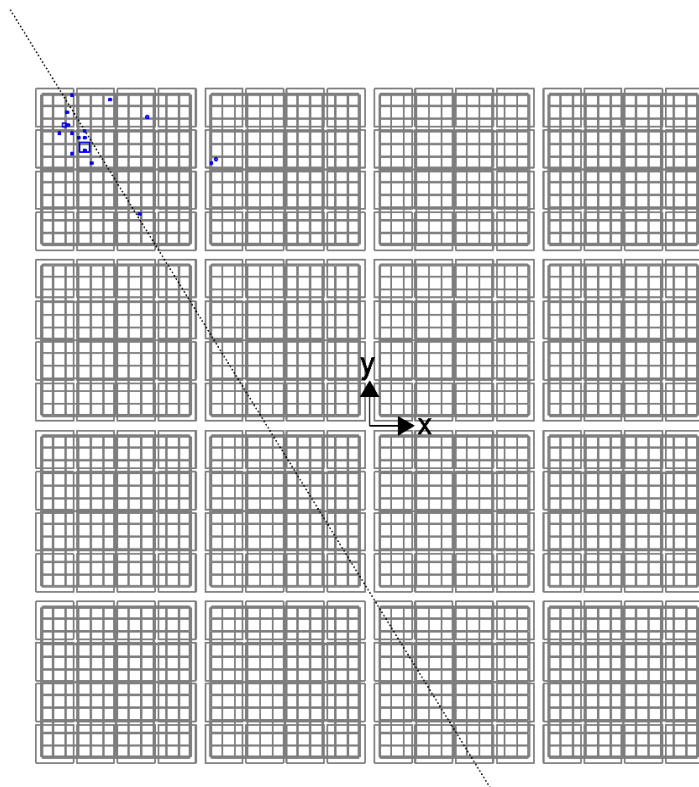
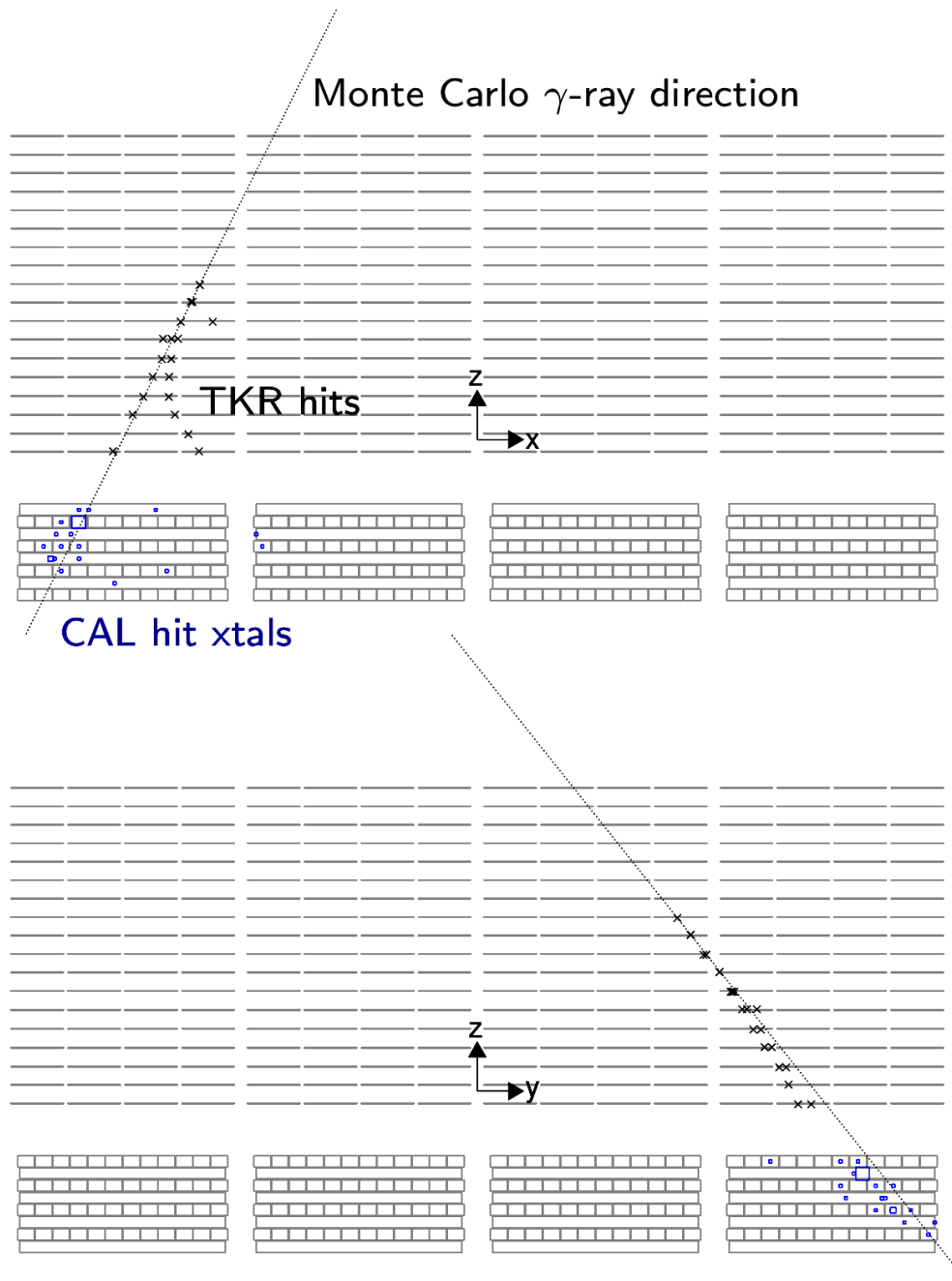

# Evento background nel LAT (protone $\sim 1\text{GeV}$ )

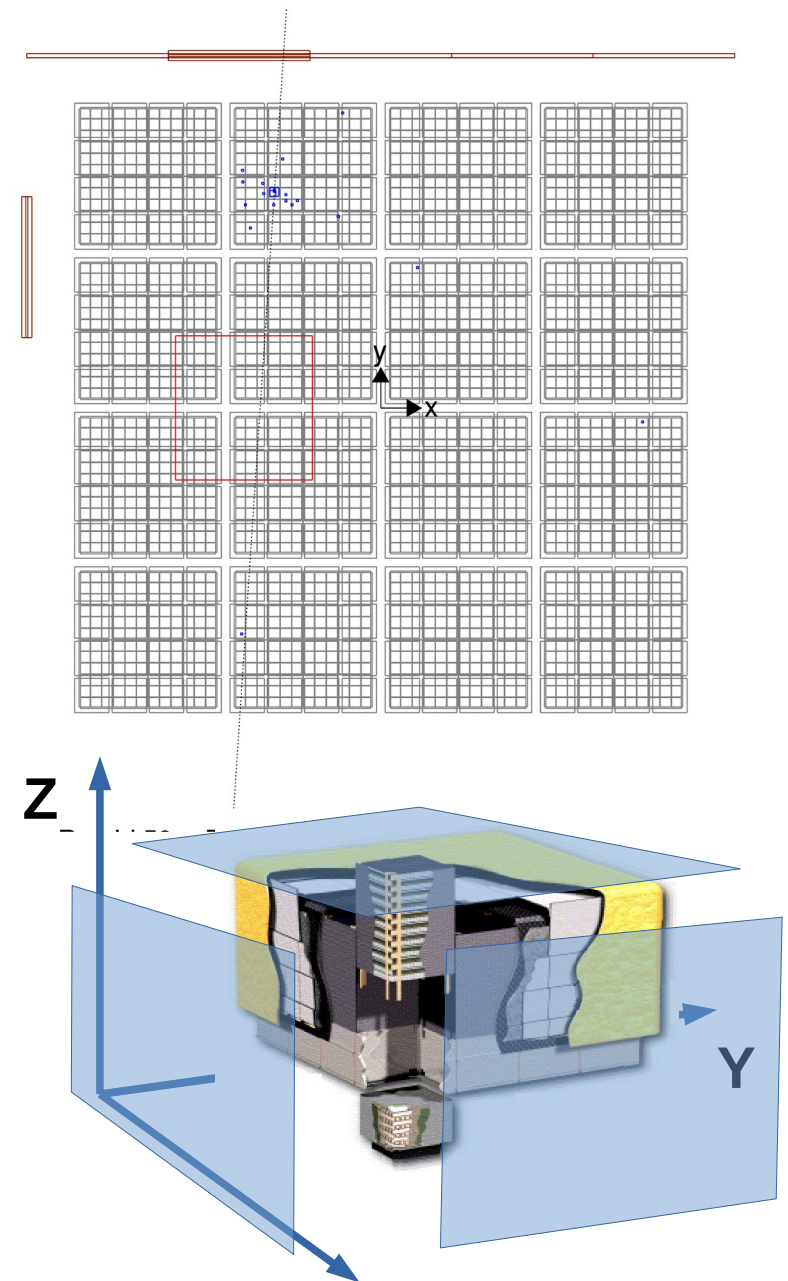
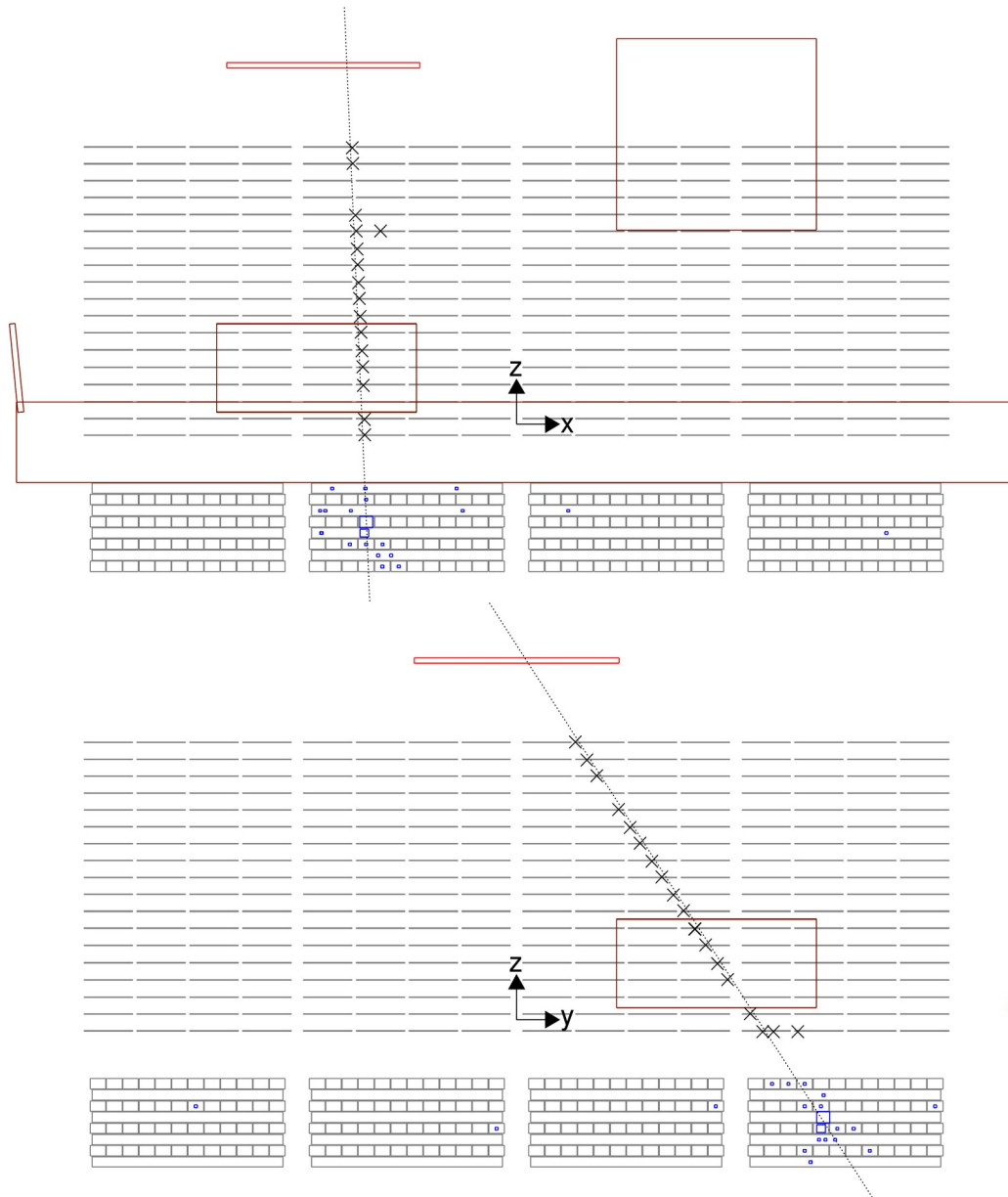

# Flussi all'orbita di Fermi

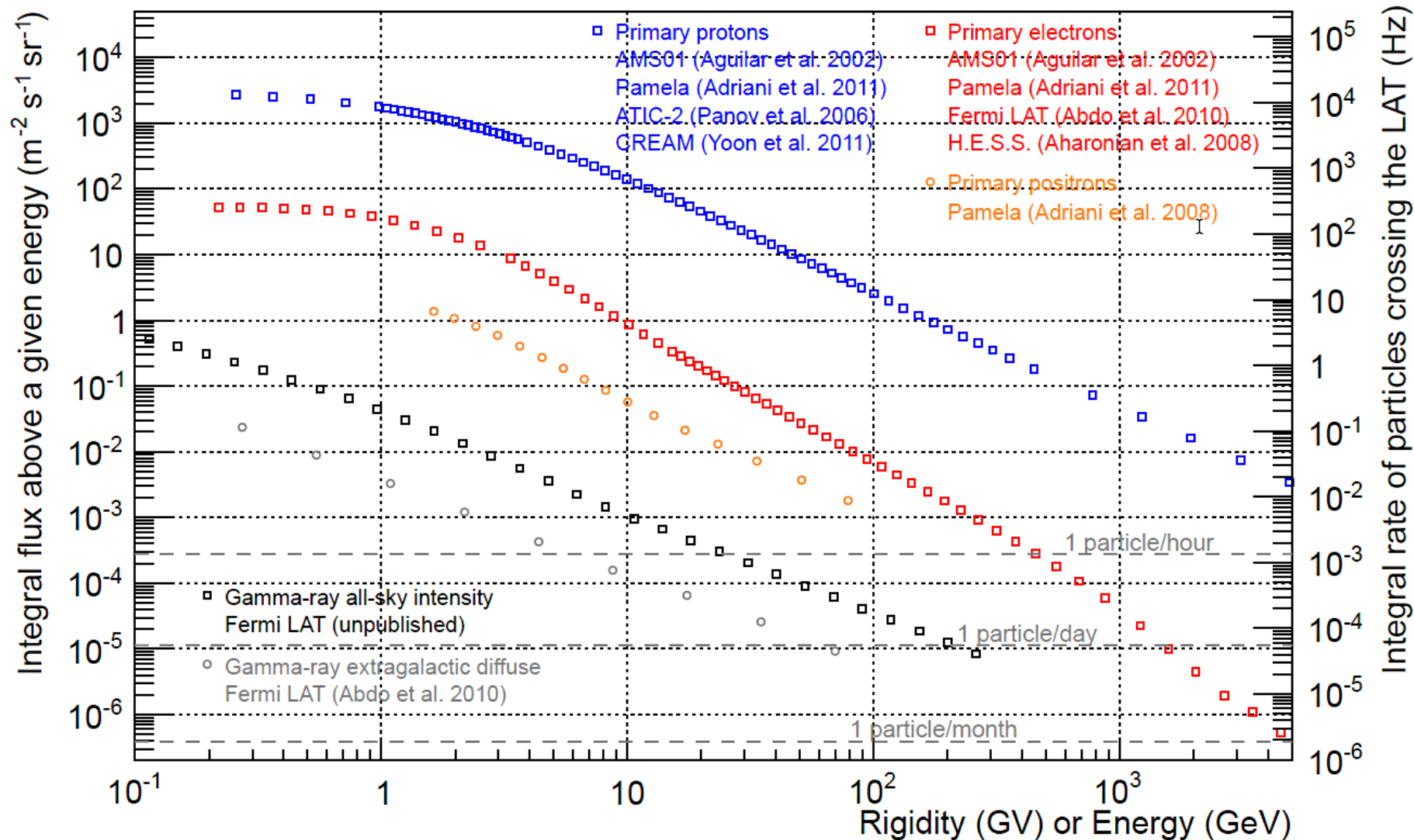

**necessaria una riduzione del background di un fattore  $\sim 10^6$**

ACD + "forma" dello sciame nel calorimetro

# Sciame elettromagnetico vs sciame

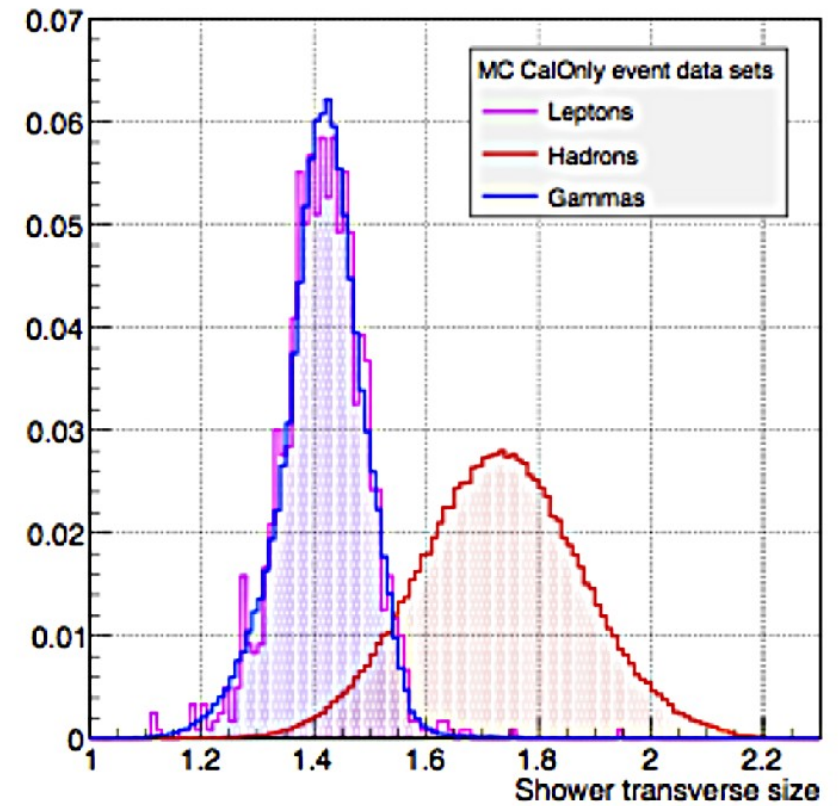
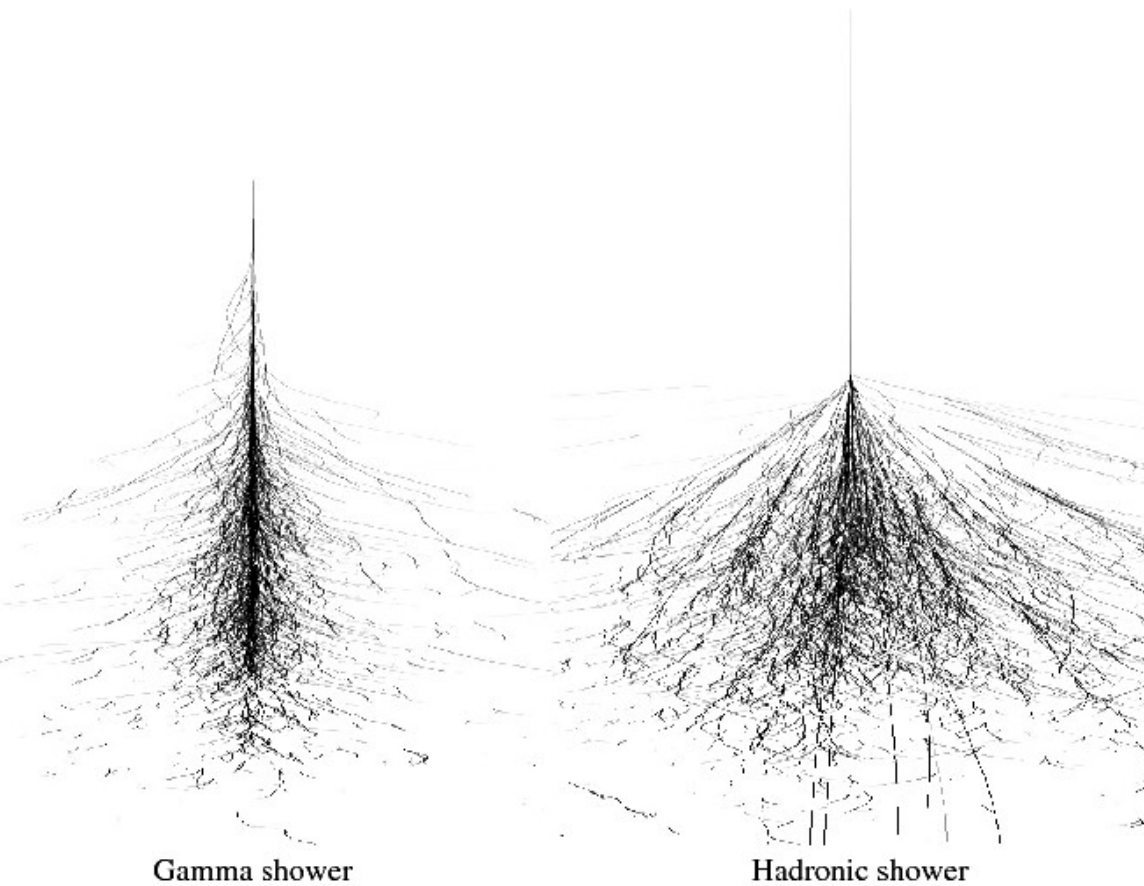

# Data processing

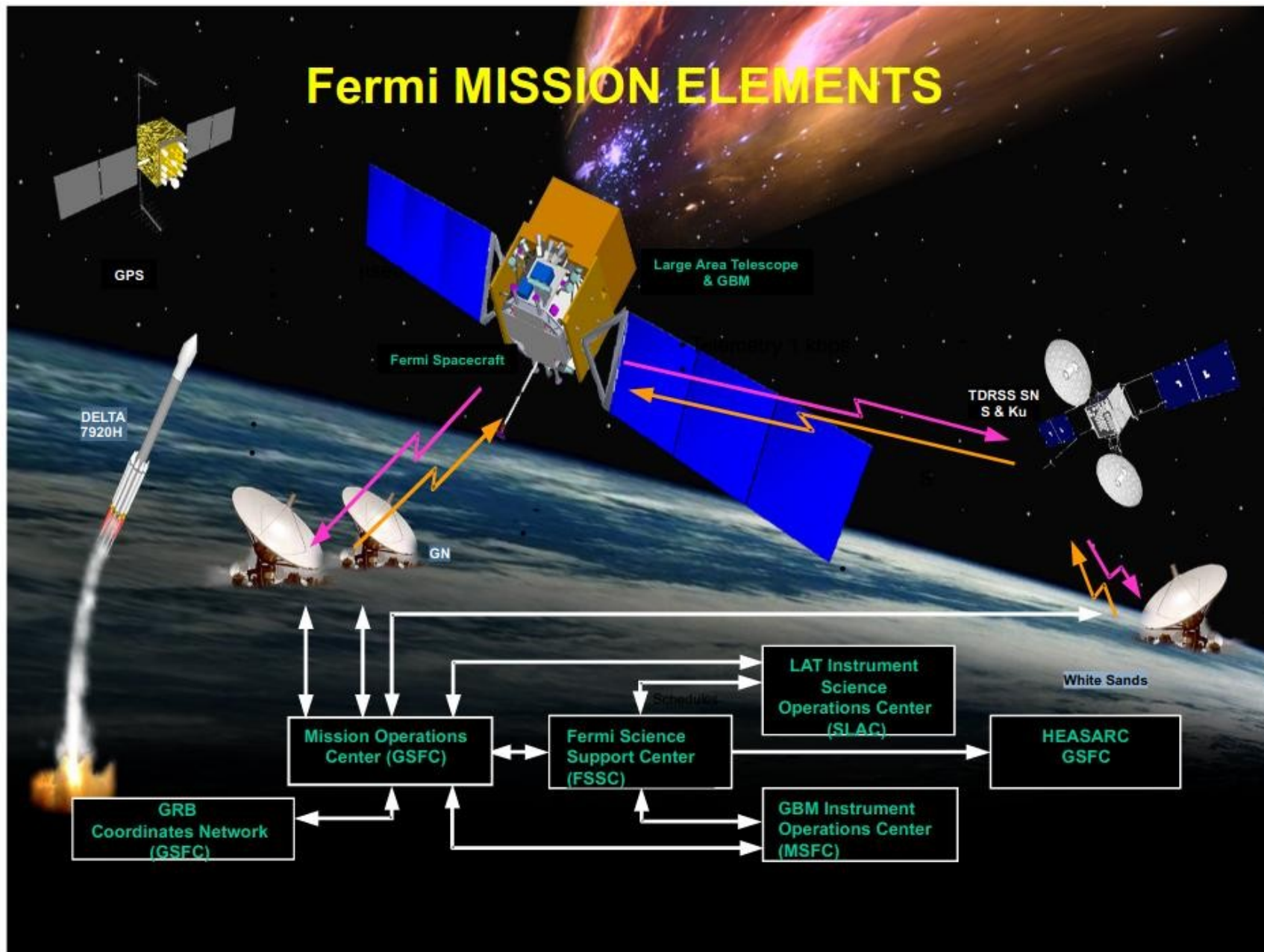

# Data processing

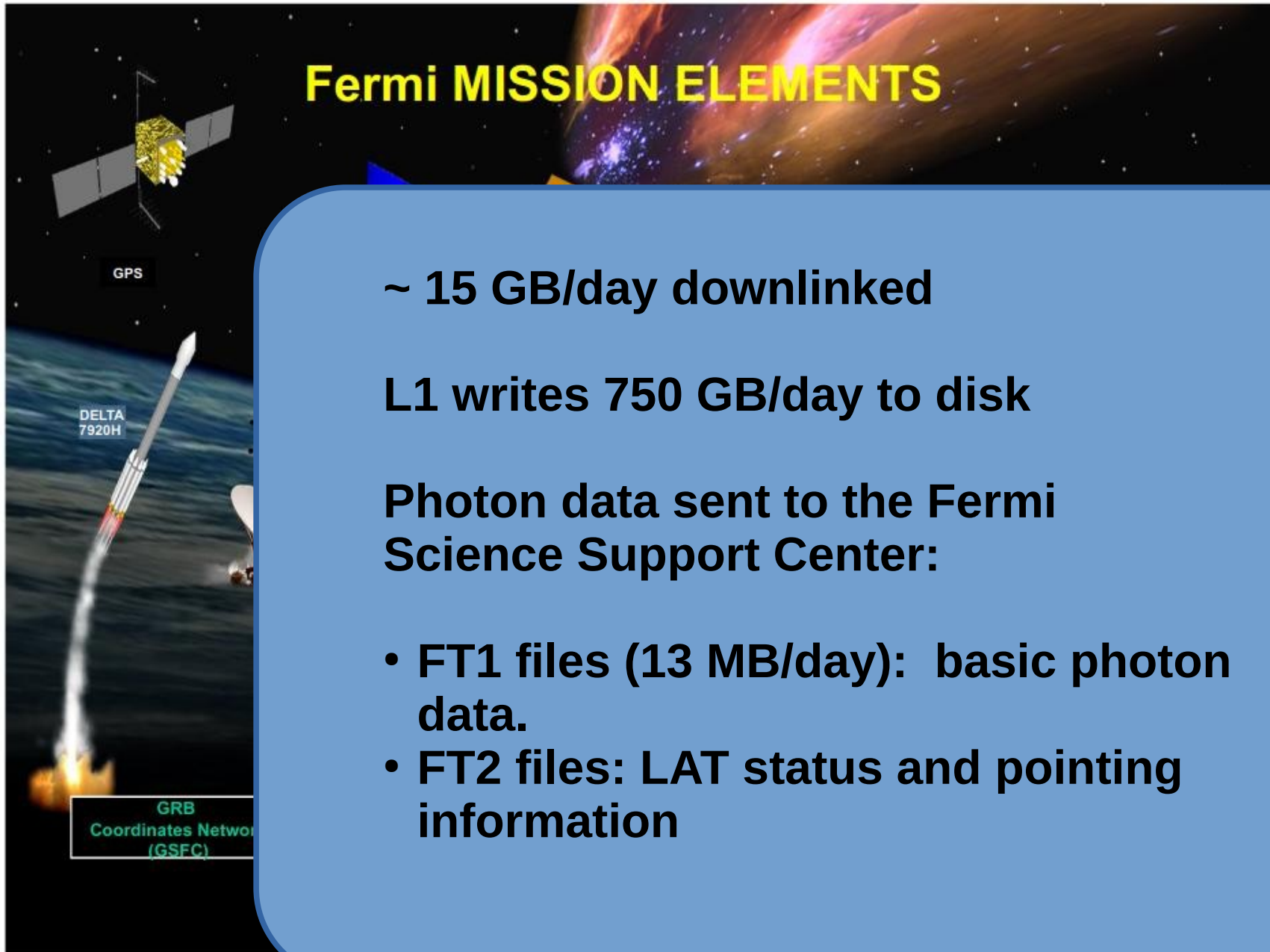
A composite image titled "Fermi MISSION ELEMENTS" in yellow text. The top right shows a colorful nebula. The left side features a satellite labeled "GPS" in orbit, a rocket labeled "DELTA 7920H" launching from Earth, and a box labeled "GRB Coordinates Network (GSFC)".

**Fermi MISSION ELEMENTS**

~ 15 GB/day downlinked

L1 writes 750 GB/day to disk

Photon data sent to the Fermi Science Support Center:

- FT1 files (13 MB/day): basic photon data.
- FT2 files: LAT status and pointing information

# Esempi dati nei files FT2

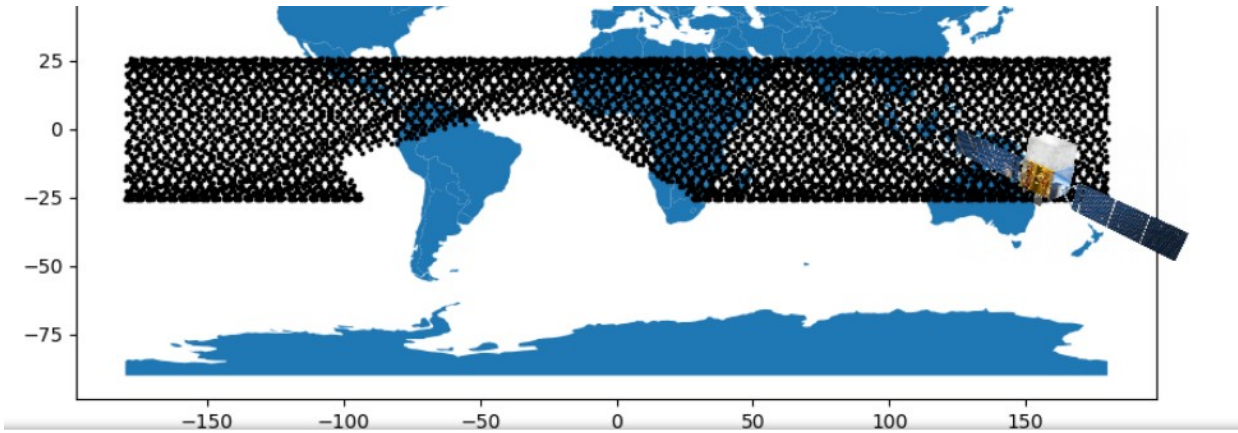

Posizione

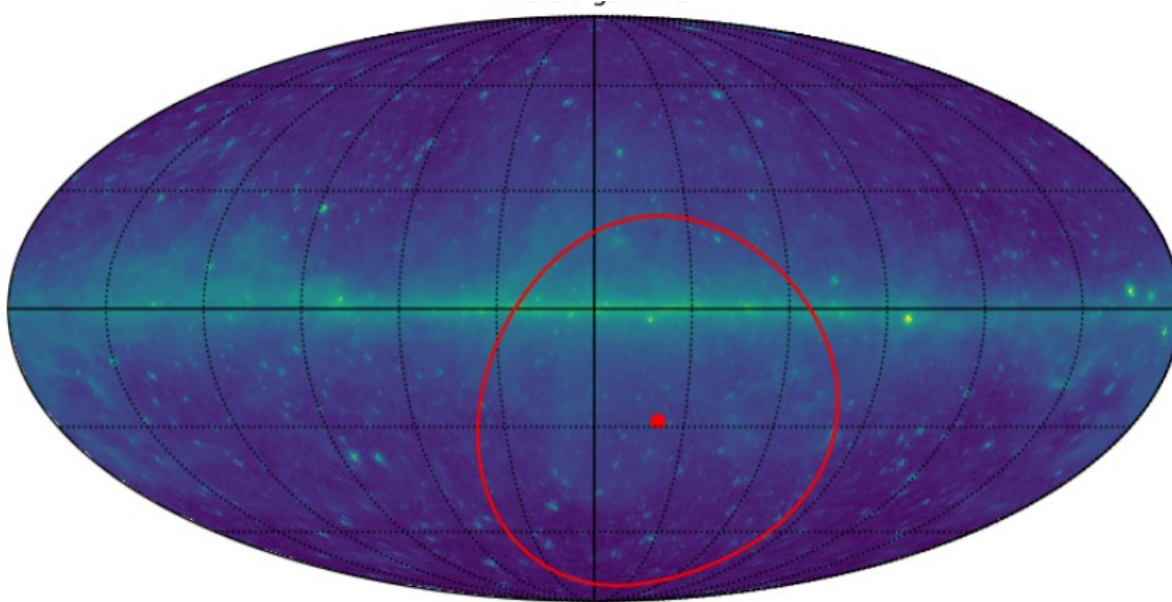

Puntamento

# Eventi gamma

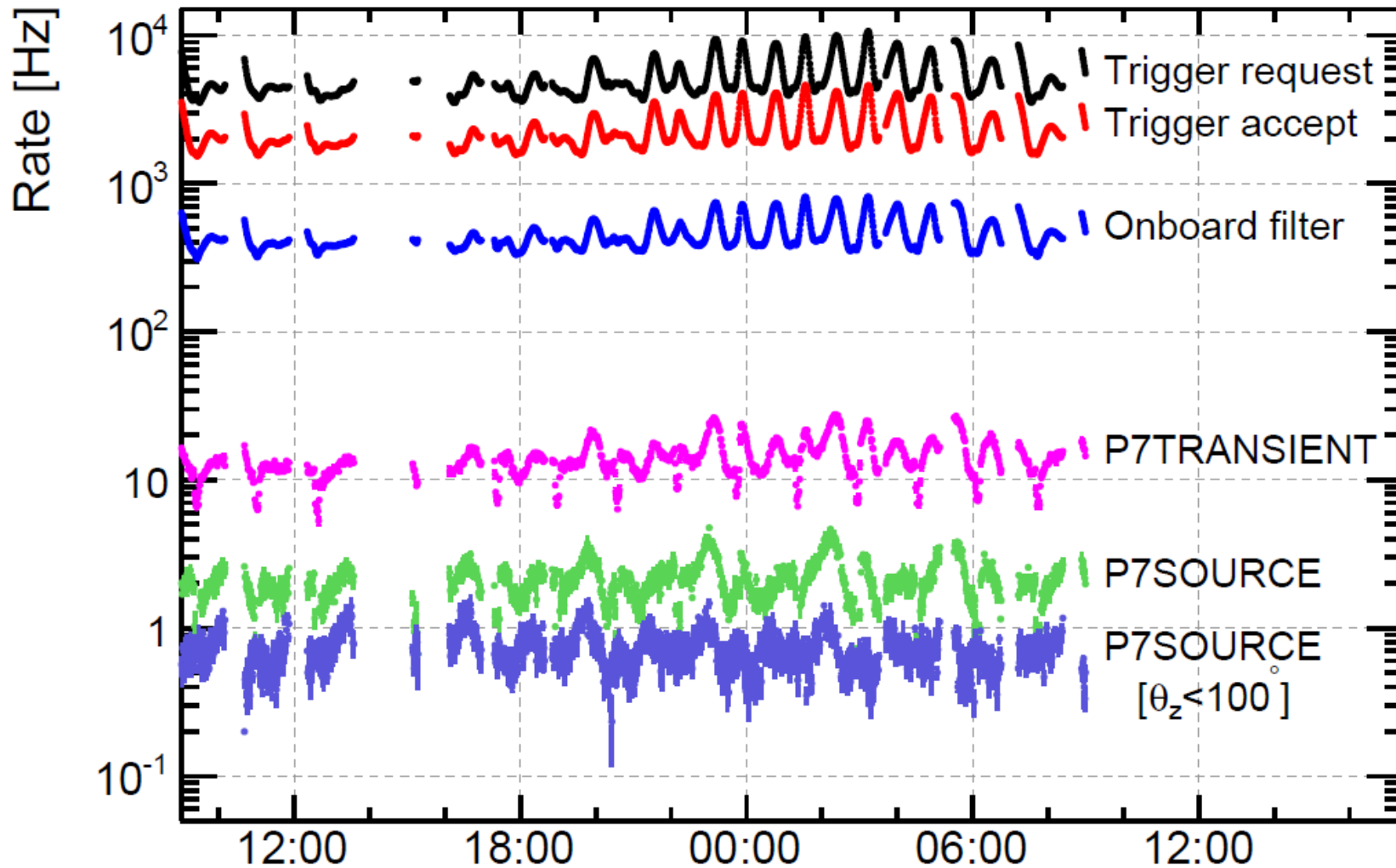

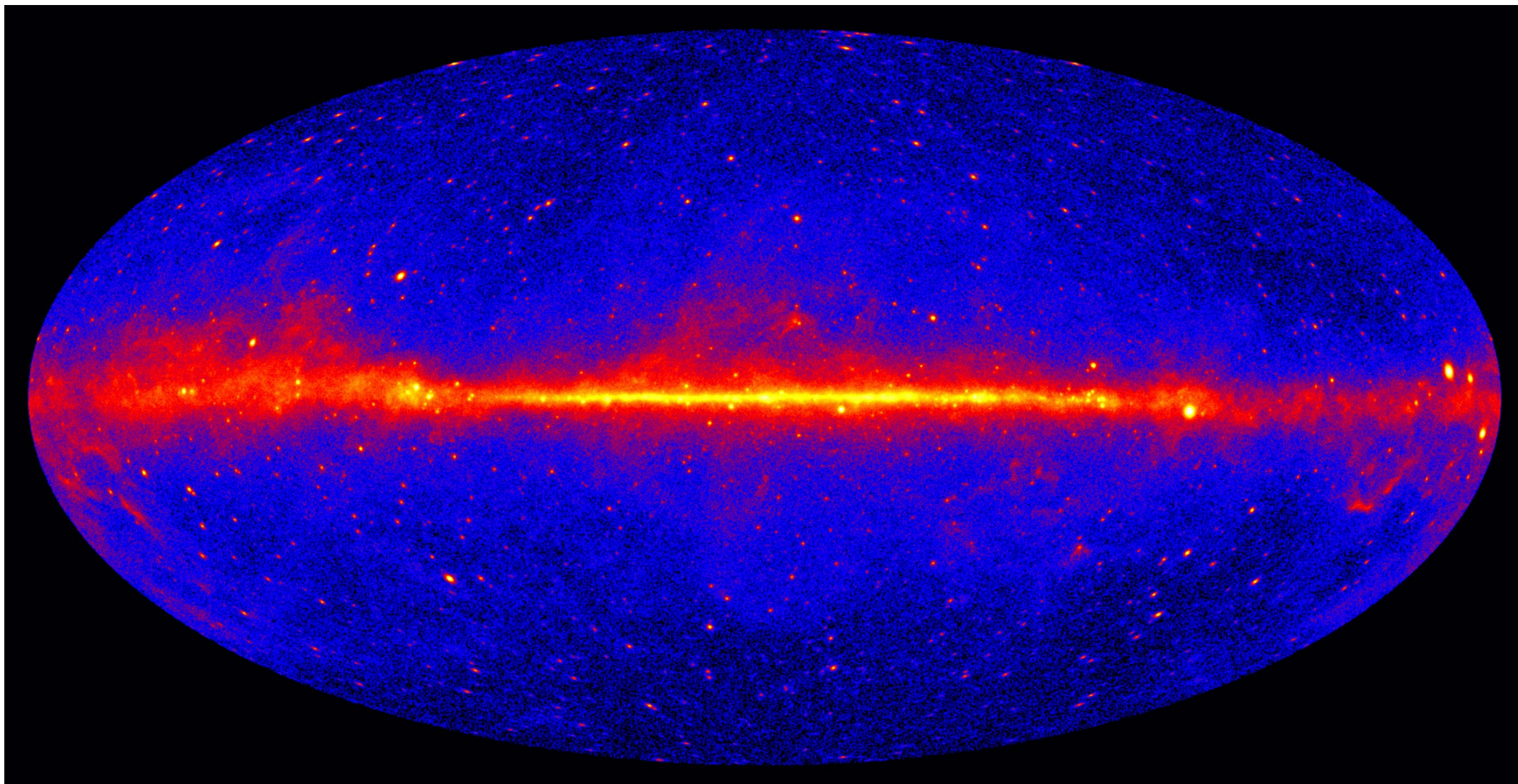



# Kahoot!

Game PIN

Enter

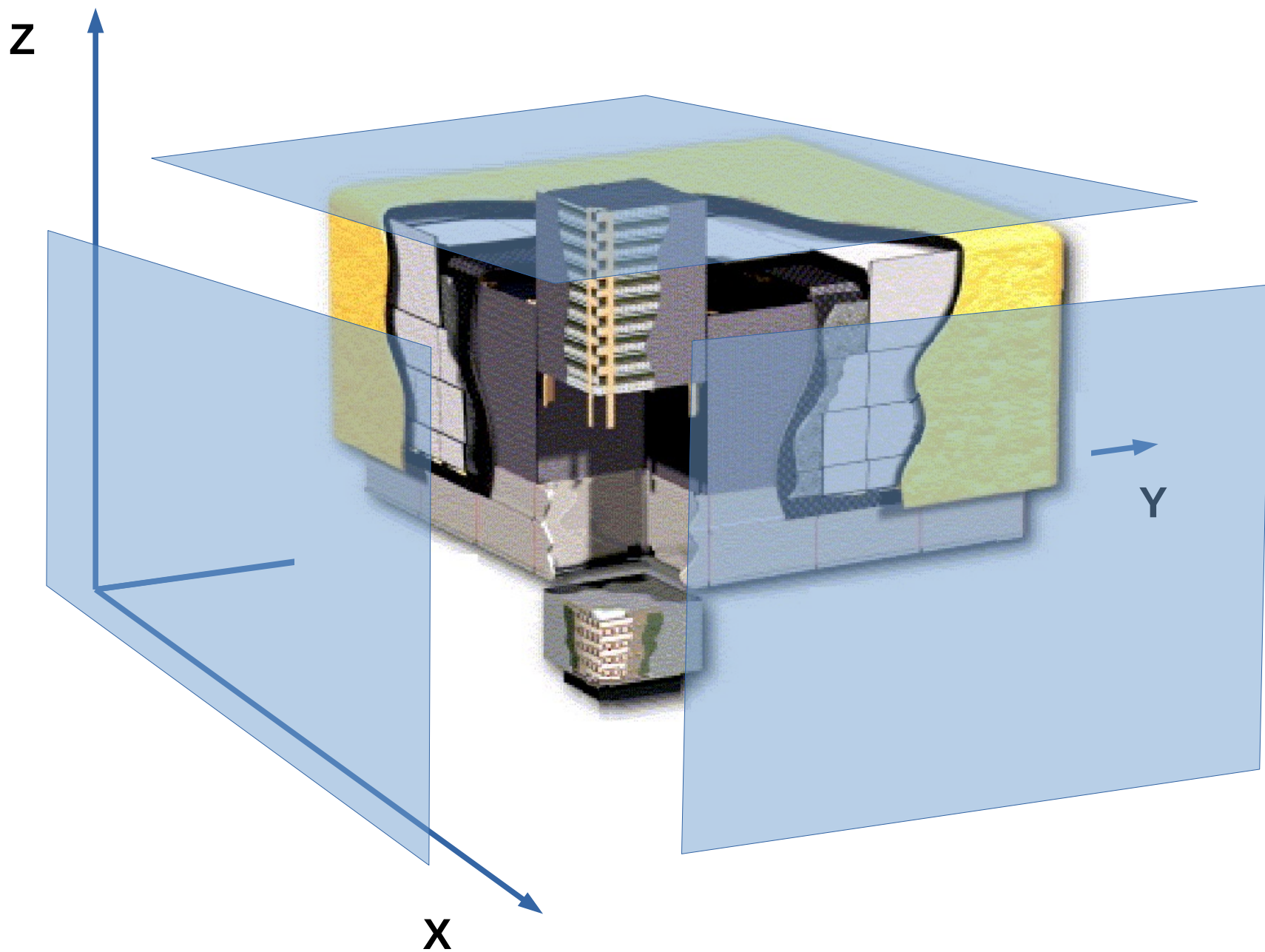

# LAT Performances

P8R3\_SOURCE\_V2 acc. weighted PSF

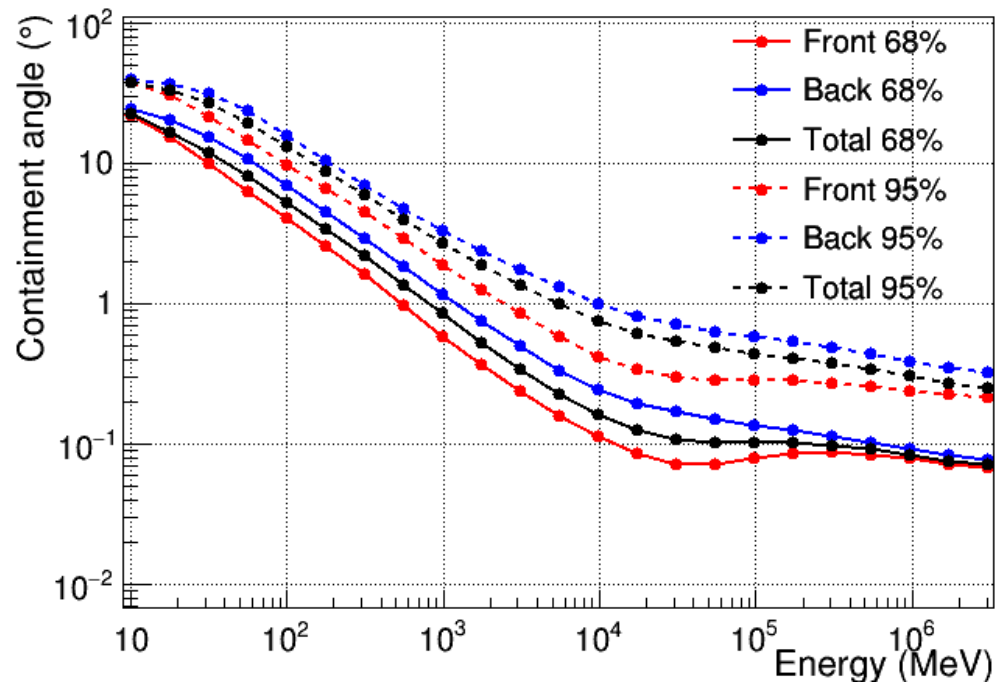

P8R3\_SOURCE\_V2 acc. weighted energy resolution

