

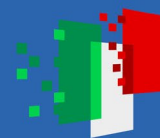

Finanziato  
dall'Unione europea  
NextGenerationEU



Ministero  
dell'Università  
e della Ricerca



Italiadomani  
PIANO NAZIONALE  
DI RIPRESA E RESILIENZA



# IRIS Green Superconducting Line (GSL)

Stefano Maffezzoli Felis

**Advisor:** Dott. Marco Statera

**Supervisor:** Prof. Lucio Rossi

PhD Thesis Defense

14/01/2026





## Outline

- The IRIS Project
- The Green Superconducting Line (GSL)
- Physical Behaviour
- Power Consumption and Use Cases
- Conclusion



Finanziato  
dall'Unione europea  
NextGenerationEU



Ministero  
dell'Università  
e della Ricerca

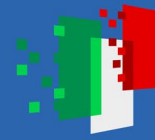

Italiadomani  
PIANO NAZIONALE  
DI RIPRESA E RESILIENZA



# The IRIS Project

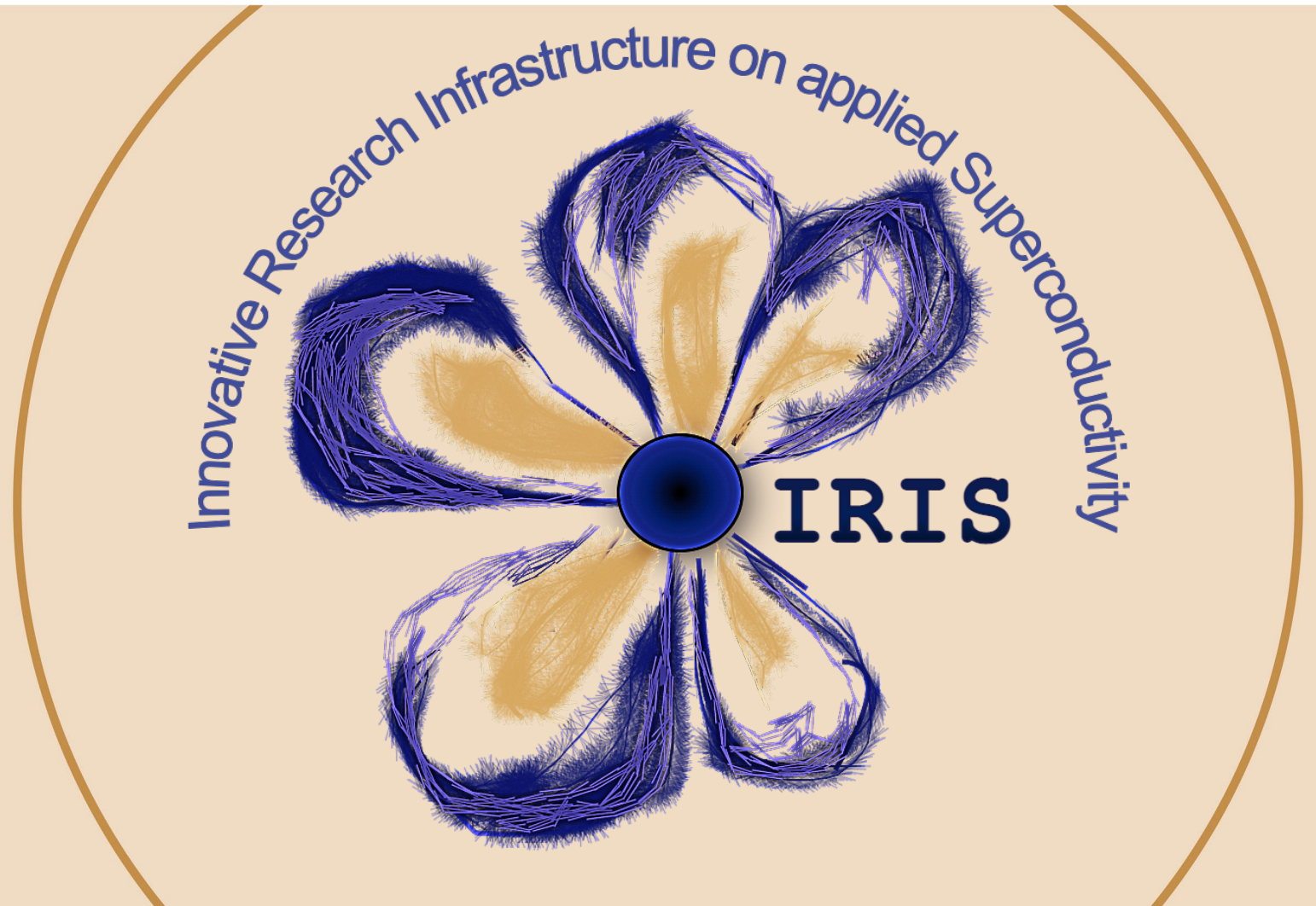

# The IRIS Project

## Innovative Research Infrastructure for applied Superconductivity

### Goal

Establishing a **national research network to advance applied superconductivity in Italy** for next-generation particle accelerators and energy-saving 'green' power solutions.

### Involved Institutions

- Milano LASA (INFN, University)
- Genova (INFN, University, CNR-SPIN)
- Frascati (INFN LNF)
- Napoli (University, CNR-SPIN)
- Lecce (Salento University)
- Salerno (INFN, University, CNR-SPIN)



### Work-packages Structure

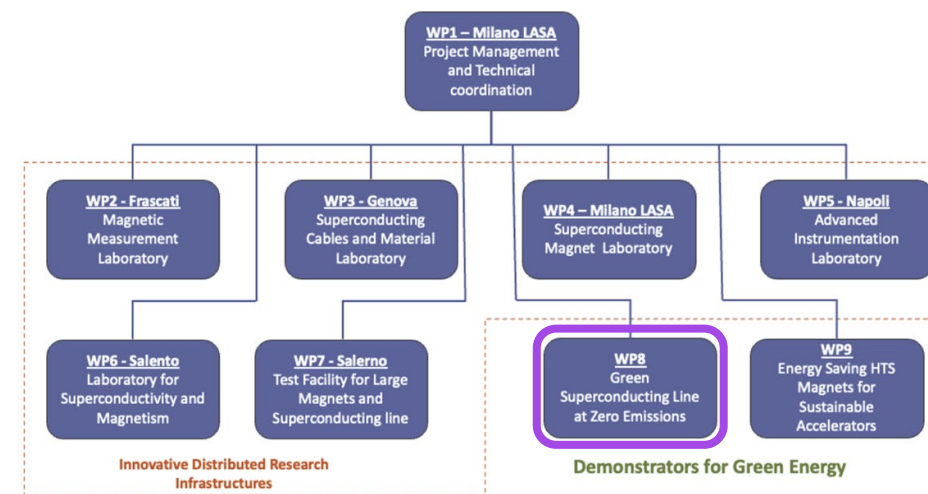



Finanziato  
dall'Unione europea  
NextGenerationEU



Ministero  
dell'Università  
e della Ricerca

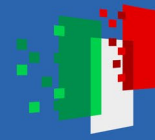

Italiadomani  
PIANO NAZIONALE  
DI RIPRESA E RESILIENZA



# The Green Superconducting Line (GSL)



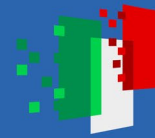

## The Green Superconducting Line (GSL)

Line characteristics	
Power transport	1 GW
Voltage	25 kV
Direct Current	40 kA
Operating temperature	20 K nominal (Min 18 K (inlet) Max 23 K (outlet))
Cooling	He gas
Line length	130 m
Expected losses	<1.5 W/m at 20 K (single cryostat)
Bending radius	2.2 m
Inner pressure	10 bar
Superconductor	MgB <sub>2</sub>
Redundancy	2 active conductors



Single pole to be tested in  
Salerno IRIS test cable facility





## The Green Superconducting Line (GSL)

### Why Magnesium Diboride ( $\text{MgB}_2$ )

- **Higher Operating Temperature:**  $\text{MgB}_2$  can operate around 20 K, which is significantly higher than low-temperature superconductors (LTS), meaning it **doesn't require expensive liquid helium**.
- **Hydrogen Compatibility:** Its operating temperature is **compatible with liquid hydrogen** infrastructure, allowing a **doble energy vector**.
- **Cost-Effectiveness:** Material **costs for  $\text{MgB}_2$  wire are lower** than those for high-temperature superconducting (HTS) tapes.
- **Simplified Cable Assembly:** The **round-wire geometry** simplifies the assembly of a multi-wire cable.
- **Commercial Availability:** It is available in **long, continuous lengths**, which **reduces or removes the need for resistive joints** common in HTS-based systems, improving overall performance and reliability.
- **Italian Excellence:** Europe — and **Italy** in particular — is the world **leader in research and development of  $\text{MgB}_2$** .

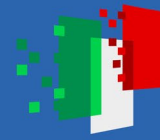

# The Green Superconducting Line (GSL)

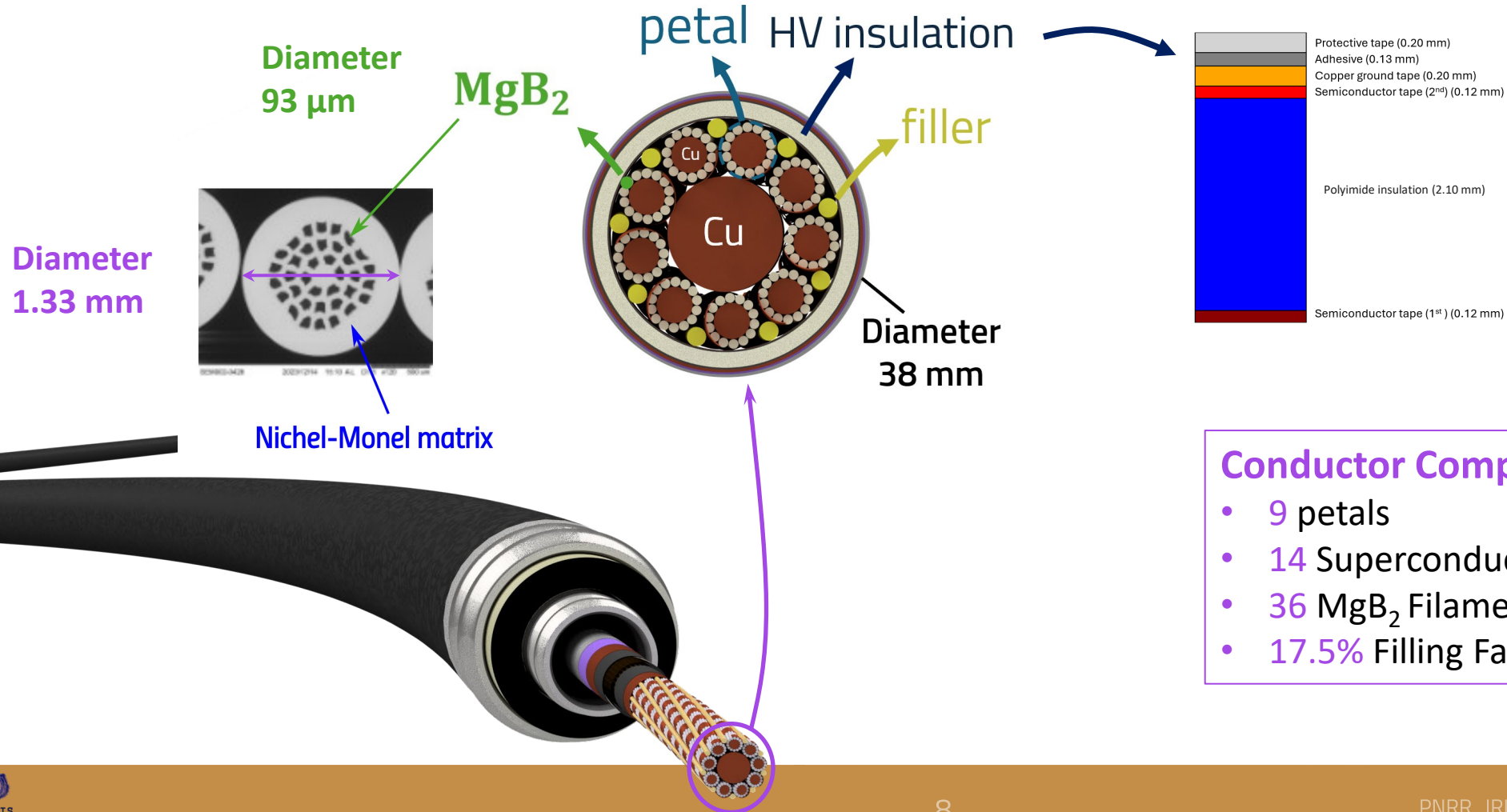

- ### Conductor Composition
- 9 petals
  - 14 Superconducting Strands
  - 36 MgB<sub>2</sub> Filaments
  - 17.5% Filling Factor



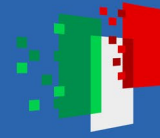

# The Green Superconducting Line (GSL)



Current Leads

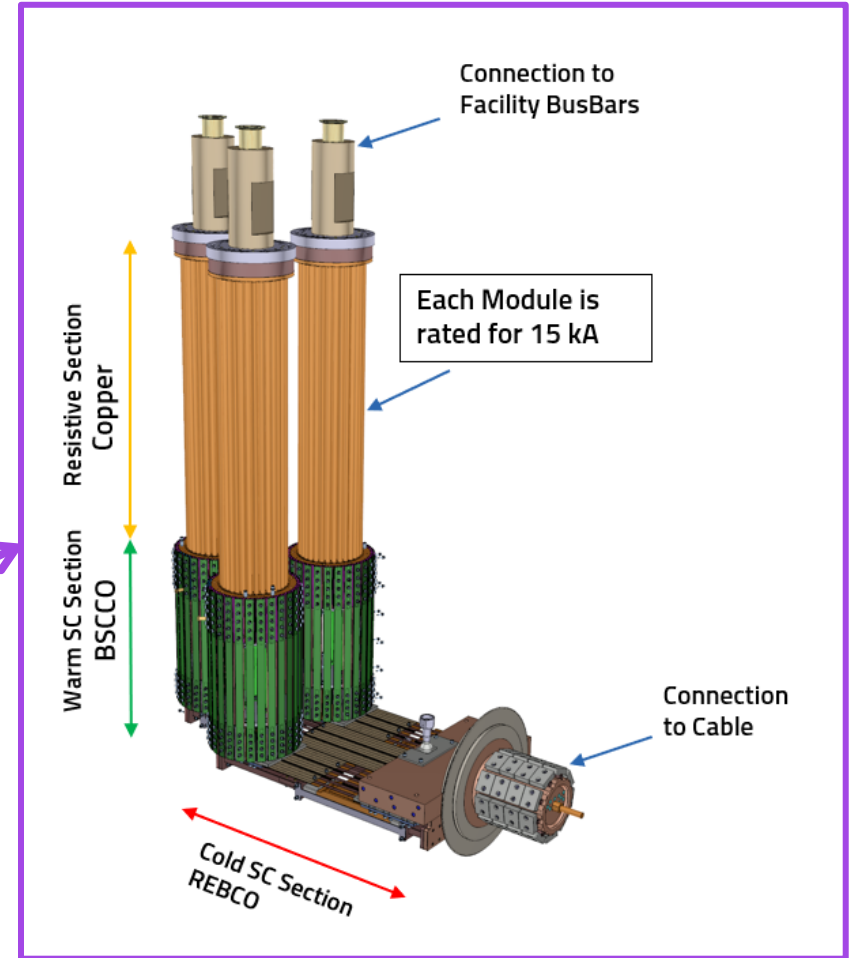
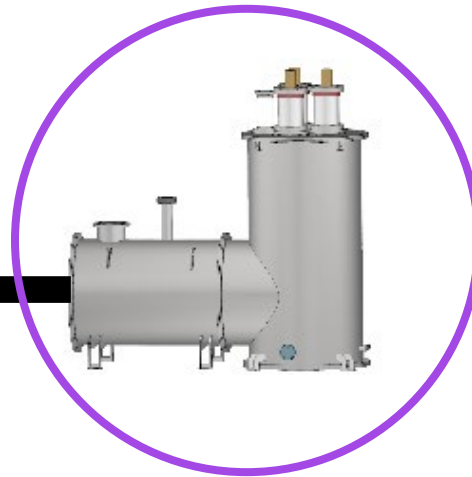

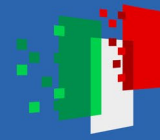

# The Green Superconducting Line (GSL)

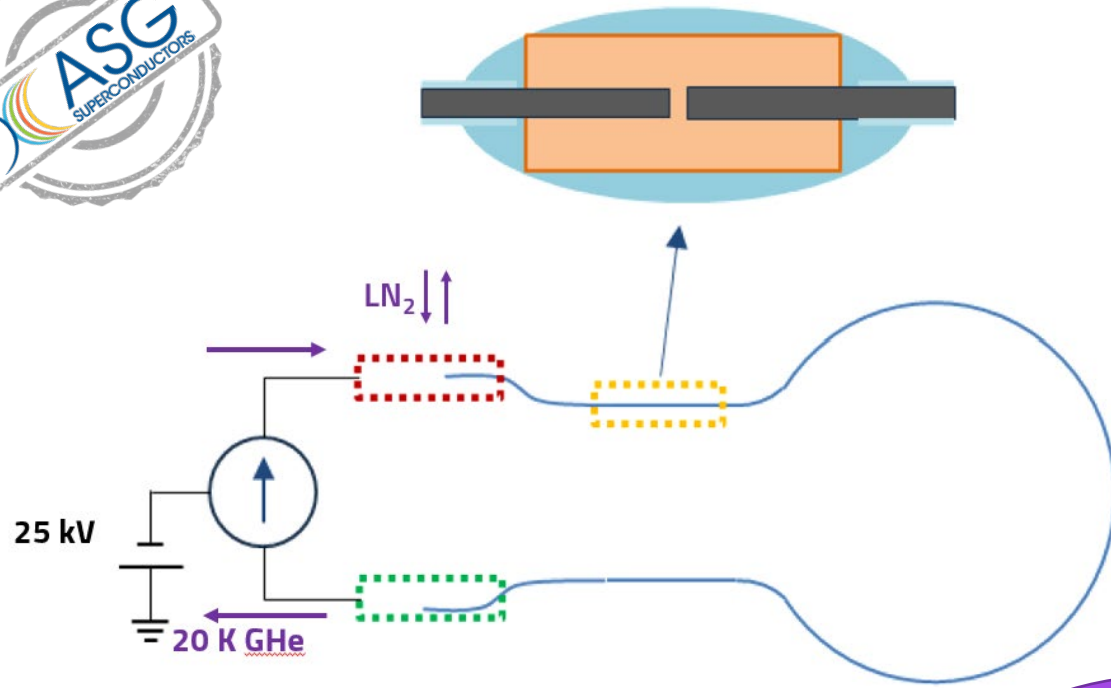

In-line junction

$R = 20 \text{ n}\Omega$

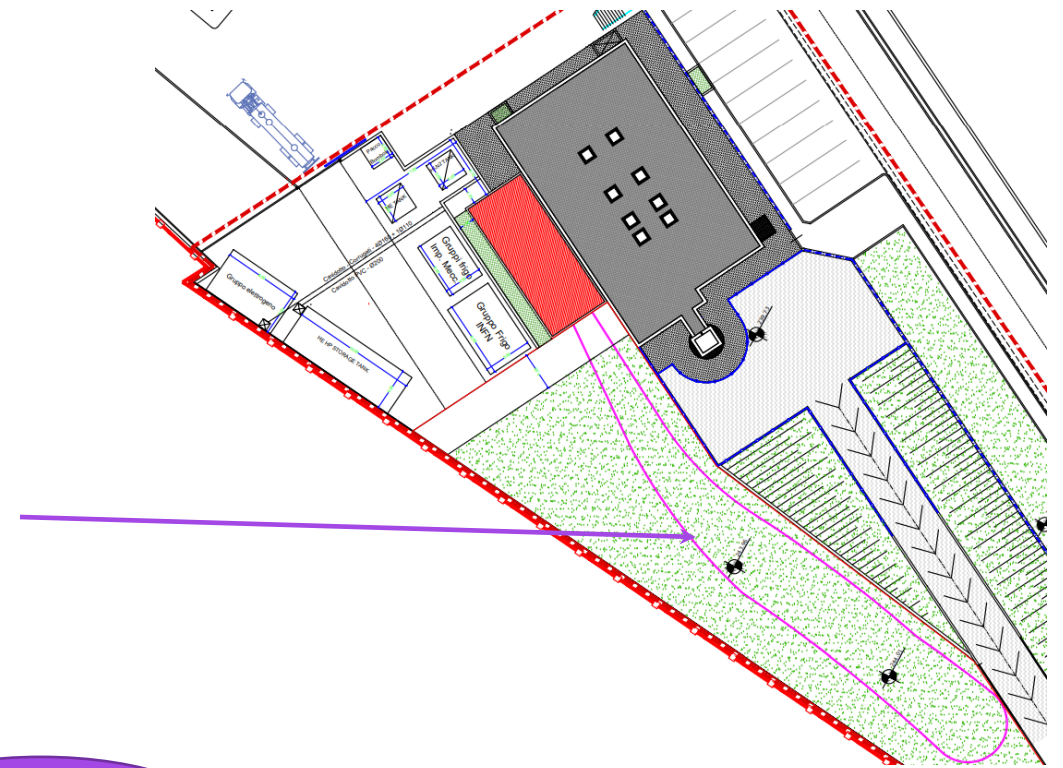

IRIS test station in Salerno





Finanziato  
dall'Unione europea  
NextGenerationEU



Ministero  
dell'Università  
e della Ricerca

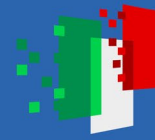

Italiadomani  
PIANO NAZIONALE  
DI RIPRESA E RESILIENZA



# Physical Behaviour

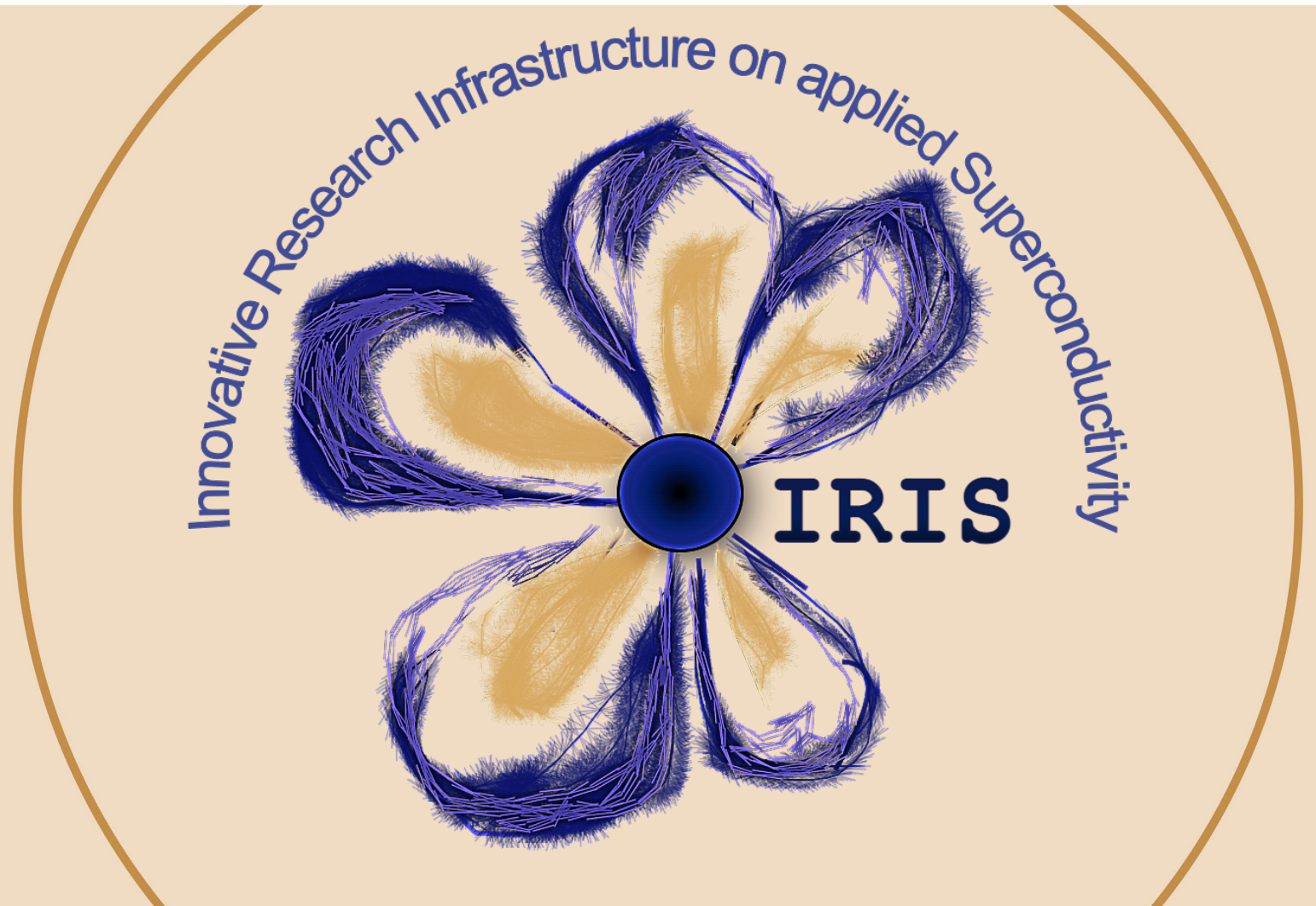

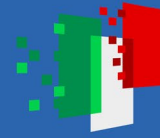

## Geometry Construction

- Mathematical definition of the **helix traces**
  - Twist pitches
  - Radii
  - Length
- Creation of the geometry following the traces
  - Number of petals
  - Number of strands

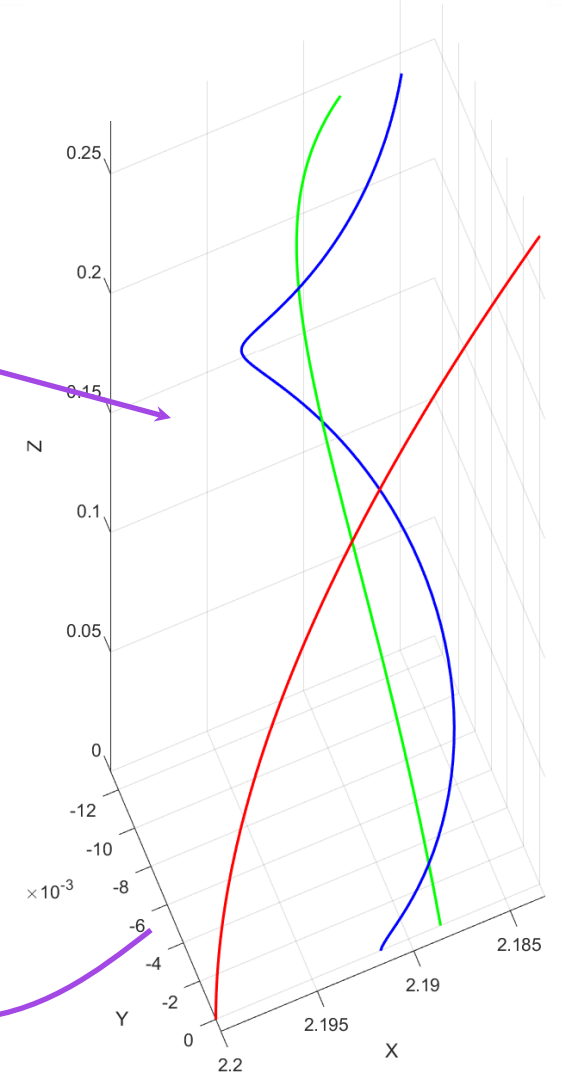
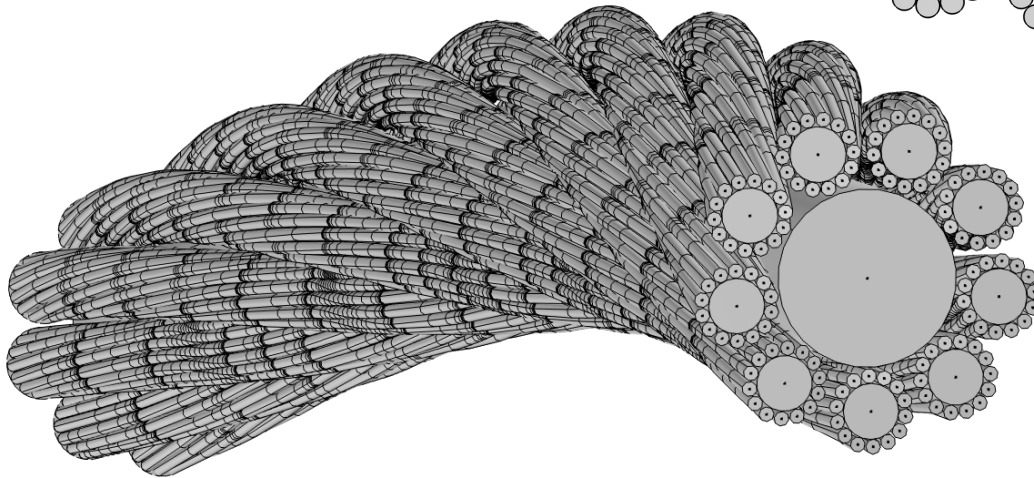
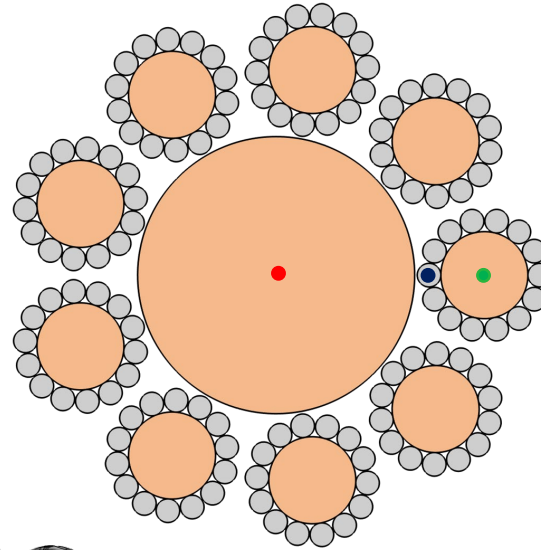

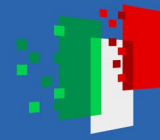

# Physical Behaviour Magnetic Analysis - 2D&3D

Single Cable

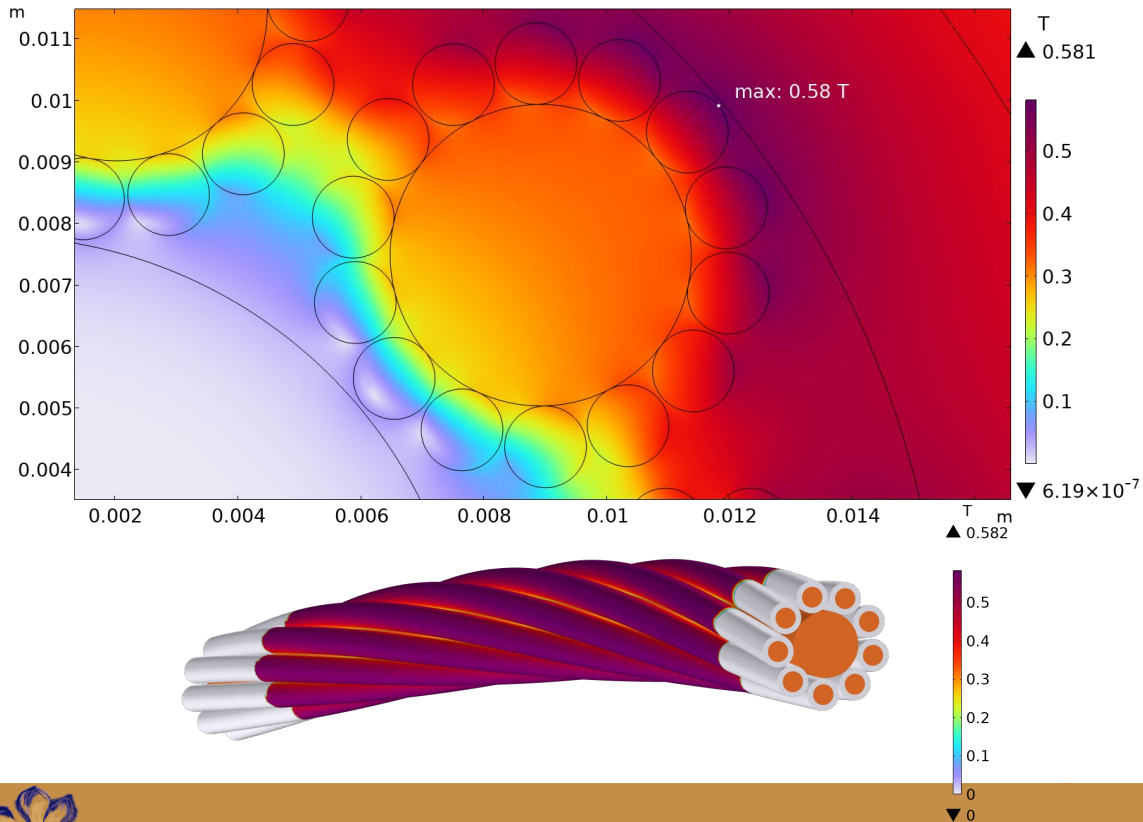

Double Cable

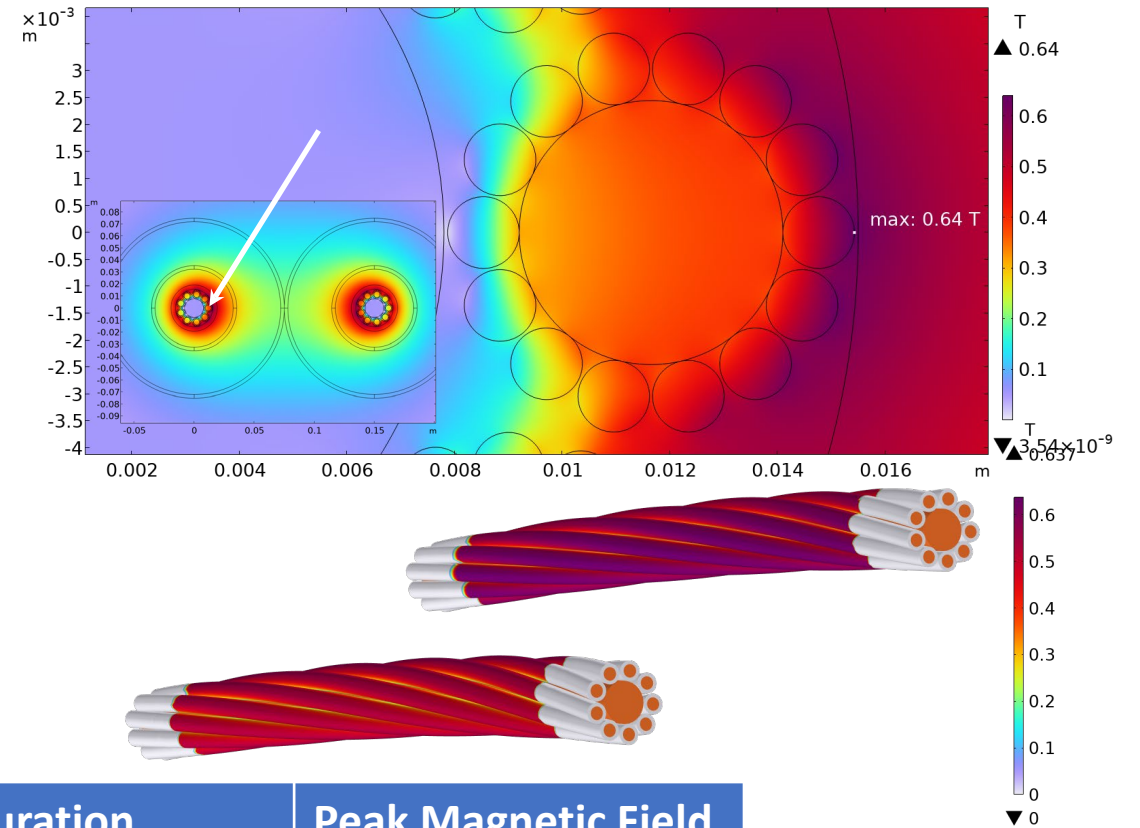

Configuration	Peak Magnetic Field
Single	0.58 T
Double	0.64 T



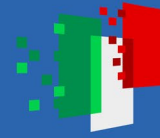

## Physical Behaviour Mechanical Analysis - Analytic

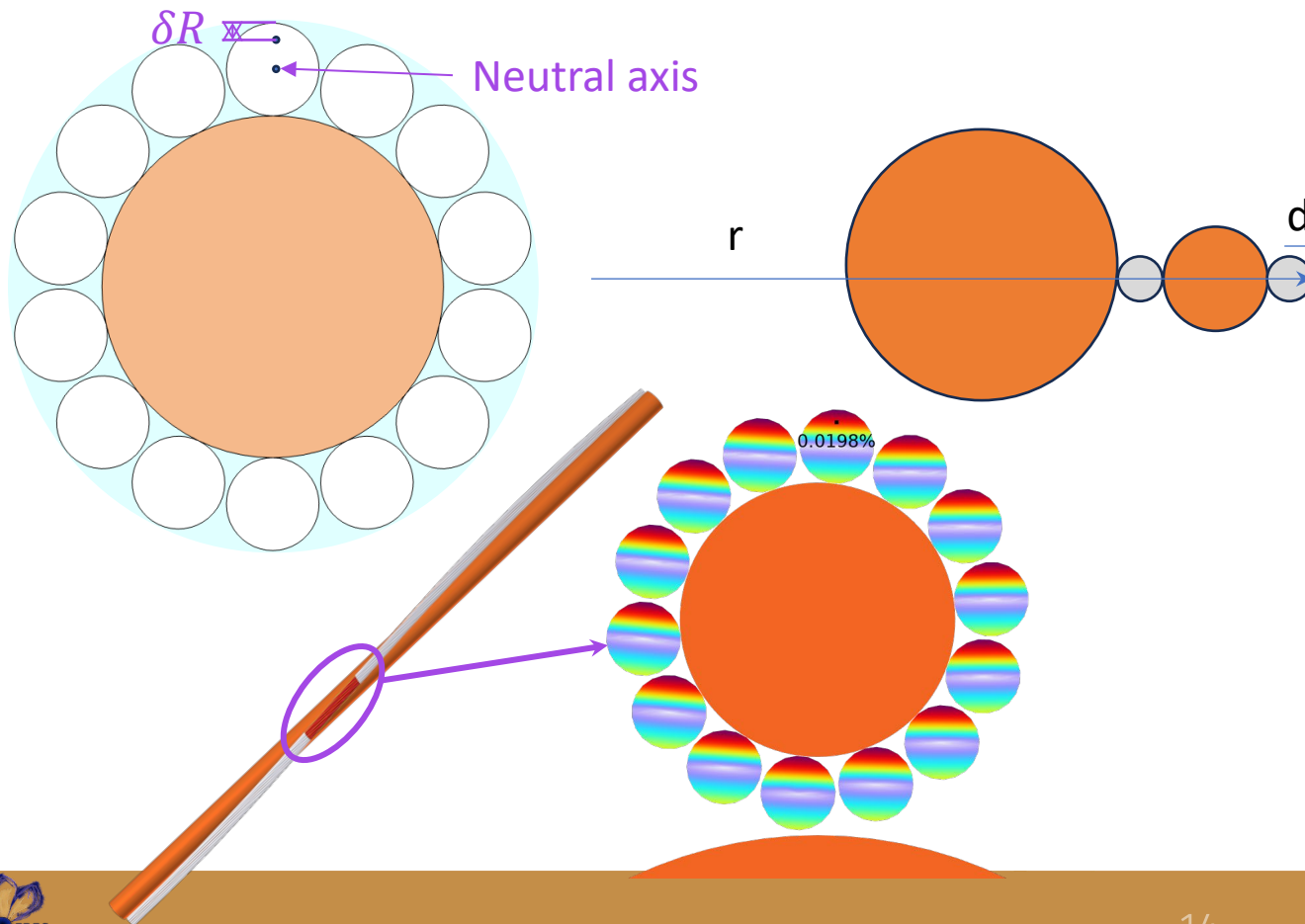

- MgB<sub>2</sub> is **strain sensitive**
- The maximum strain to have a critical current reduction of 5% is 0.3%
- Analytical calculation estimated **total strain**  $\epsilon \approx 0.15\%$

- $\epsilon = \frac{d}{R}$
- $\delta R = \frac{d}{6}$
- $R = \frac{4\pi^2 r^2 + t_p^2}{4\pi^2 r}$
- $\epsilon_{strand} \approx 8.7 \times 10^{-2}\%$
- $\epsilon_{petal} \approx 4 \times 10^{-2}\%$
- $\epsilon_{cable} \approx 1.99 \times 10^{-2}\%$

COMSOL:  $\epsilon_{cable} \approx 1.98 \times 10^{-2}\%$



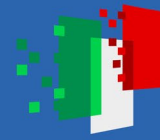

## Physical Behaviour Critical Current - Data Fit

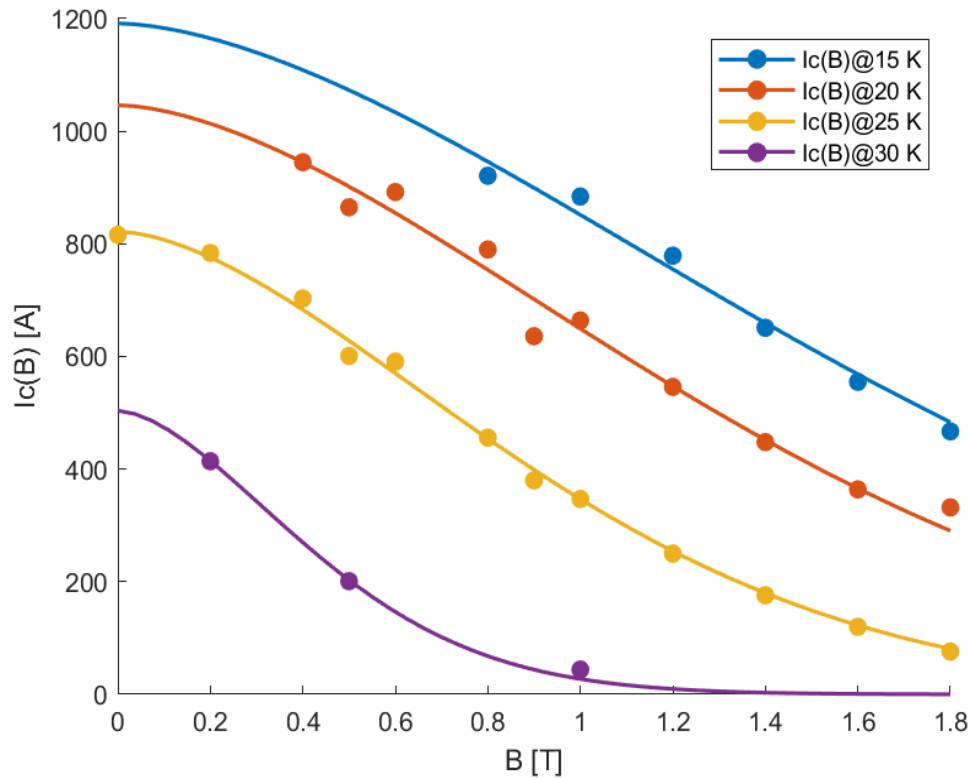

- $I_c(t, B) = I_0(1 - \alpha t^\gamma) e^{-\left(\frac{B}{B_0(1 - \beta t^\epsilon)}\right)^\delta}$   $t = \frac{T}{T_c}$
- $R^2 = 0.99$
- To be validated
- Used in the transition analysis

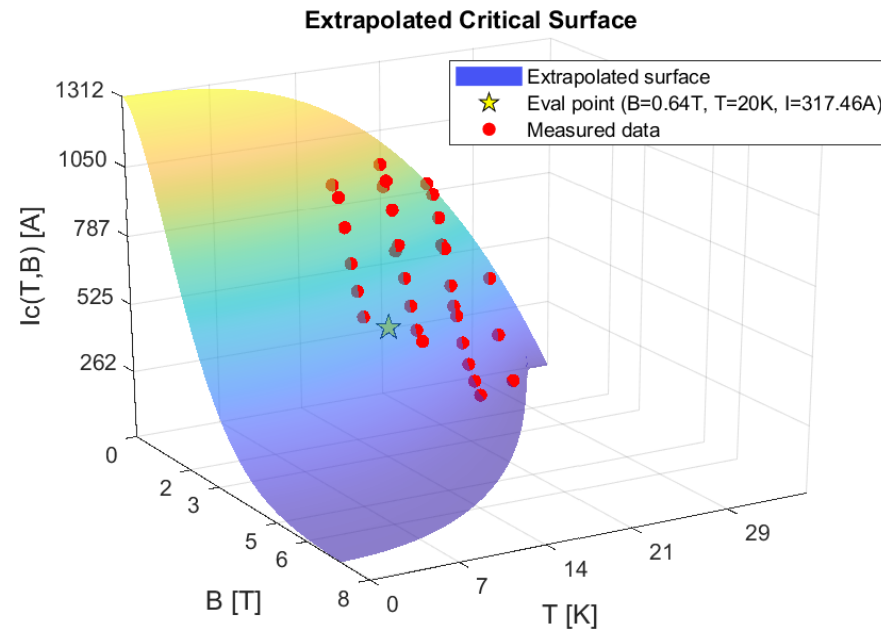

One cable  
 $\Delta T = 8.29 K$

Two cables  
 $\Delta T = 7.88 K$



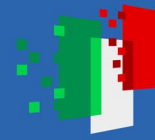

## Physical Behaviour Transition Analysis

- The objectives are to determine the **energy** required to initiate the **phase transition** between **superconducting and normal phase** of the  $\text{MgB}_2$  strands, to characterise the **temperature rise** and its propagation, and to identify the requirements for any necessary protection systems.
- **Protection** in the context of the IRIS GSL is primarily an **early-warning and reconfiguration mechanism**. Detection must identify evolving critical states with sufficient margin and lead time to route the load to redundant conductors or spare infrastructure to maintain **continuous operation**.

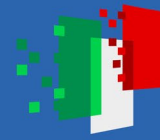

# Physical Behaviour Transition Analysis - Model

## Conductivity of the Strands

$$\sigma = \begin{pmatrix} \rho_{\parallel}(E, T, B)^{-1} & 0 & 0 \\ 0 & \rho_{\perp}(T)^{-1} & 0 \\ 0 & 0 & \rho_{\perp}(T)^{-1} \end{pmatrix}$$

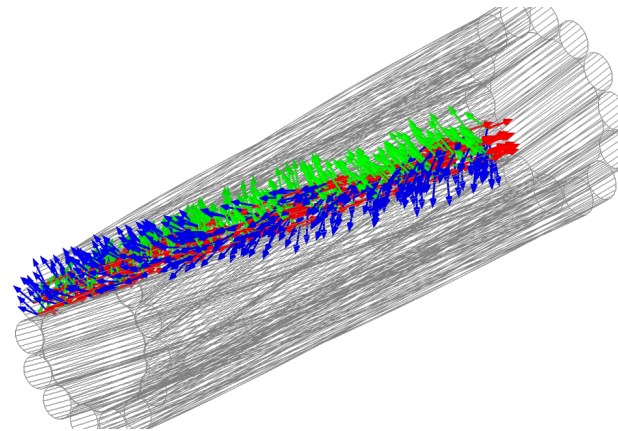

## Homogenised strand

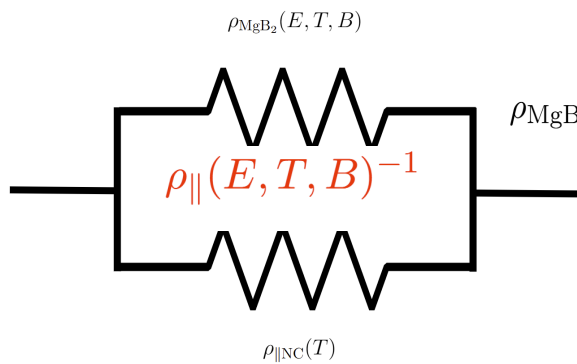
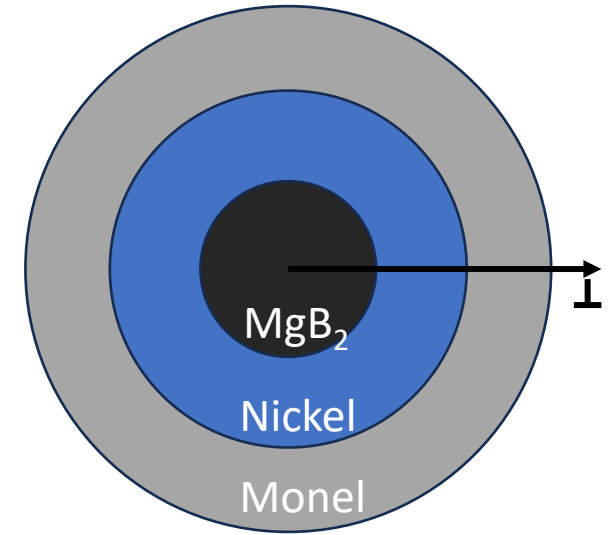

$$\rho_{MgB_2}(E, T, B) = \max \left( \frac{E^{\frac{n-1}{n}} E_0^{\frac{1}{n}}}{J_c(T, B)}, 10^{-16} \Omega m \right)$$

$$\rho_{\parallel NC}(T) = \left( \frac{1}{\rho_{Ni}(T)} + \frac{1}{\rho_{Monel}(T)} \right)^{-1}$$

$$\rho_{\perp}(T) = \rho_{Ni}(T) + \rho_{Monel}(T)$$

Two cables  
 $B = 0.64 T$

MgB<sub>2</sub>  
17.5%

NC Matrix  
82.5%



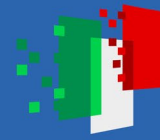

## Physical Behaviour Transition Analysis - Model

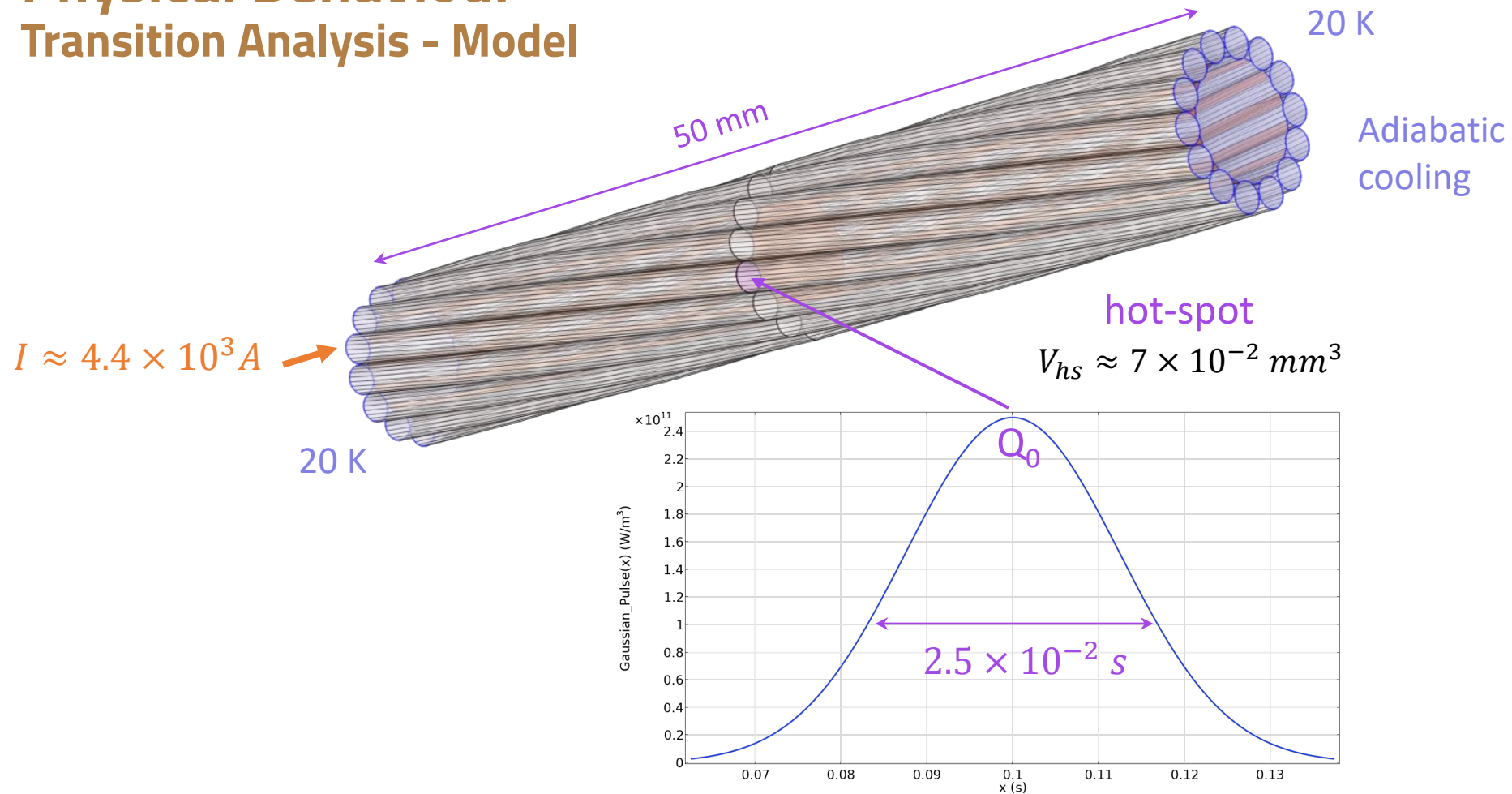

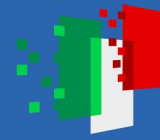

# Physical Behaviour Transition Analysis - Results

Parametric evaluation of  $Q_0$

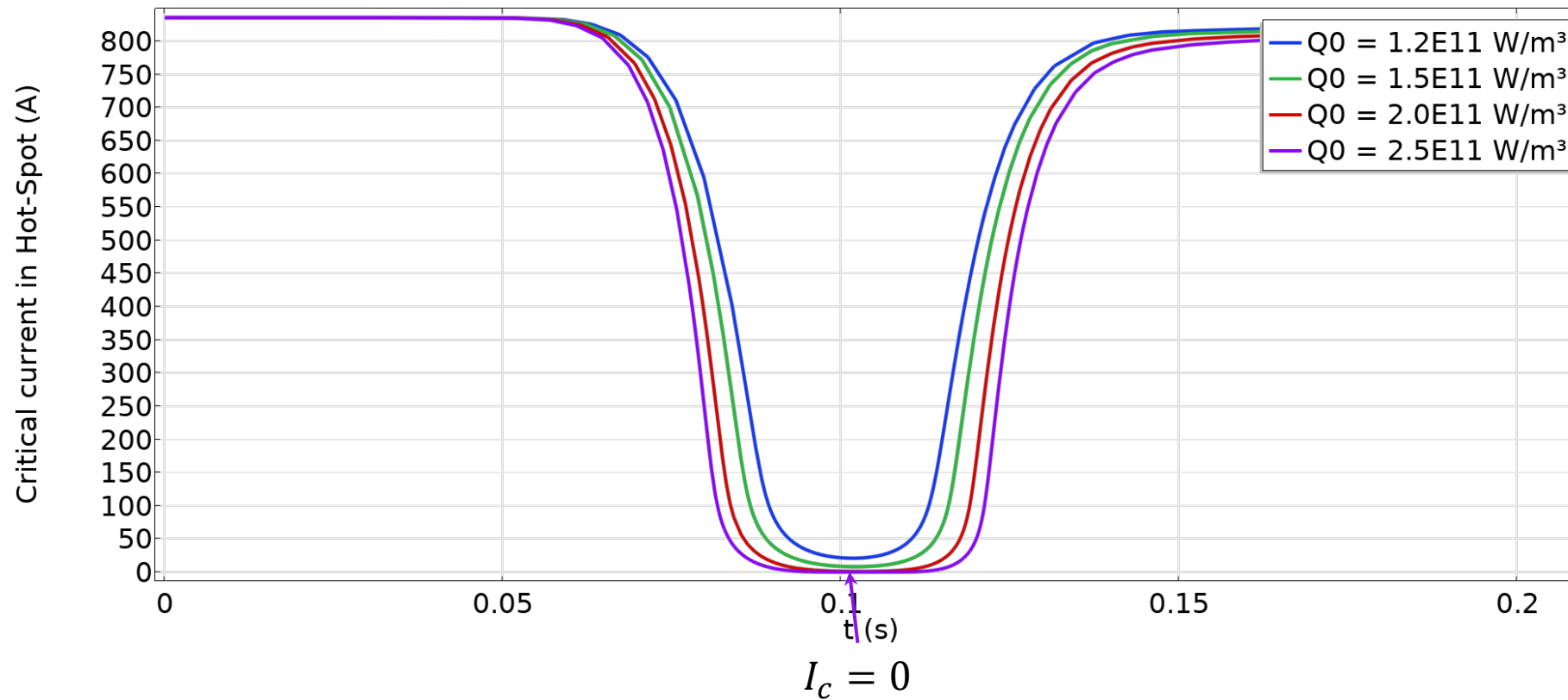

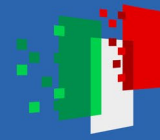

# Physical Behaviour Transition Analysis - Results

$$Q_0 = 2.5 \times 10^{11} \frac{W}{m^3}$$

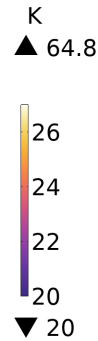
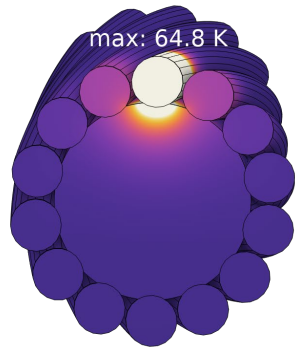

Temperature

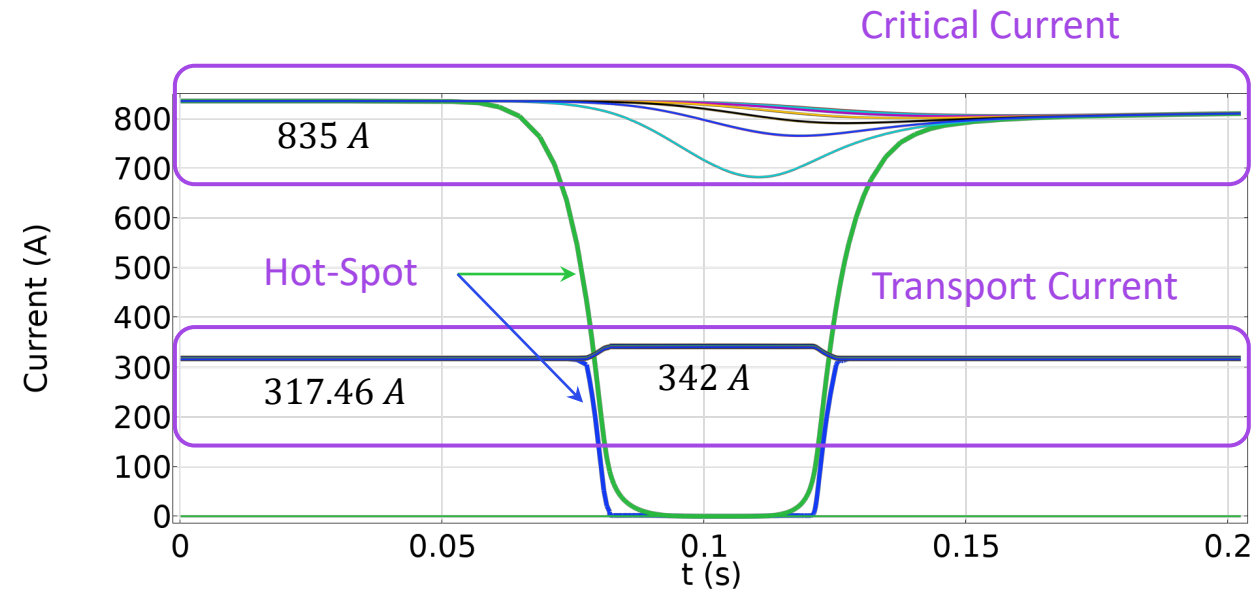
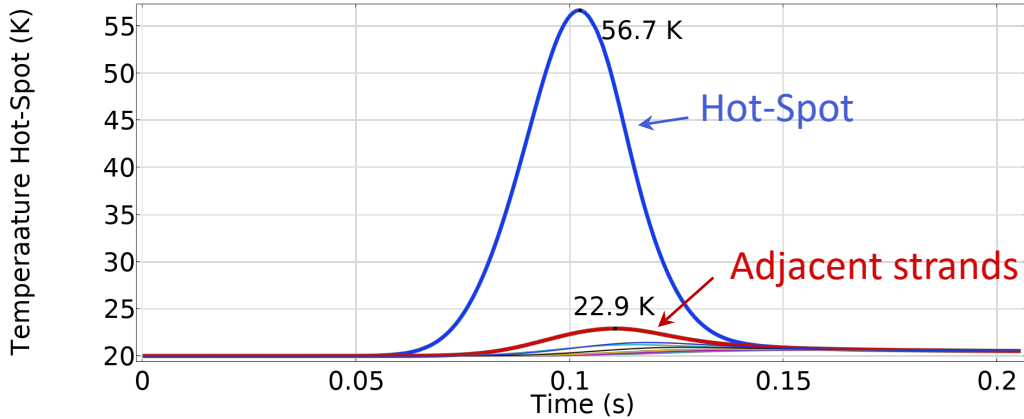

The cable recover after the transition  
**No thermal runaway**



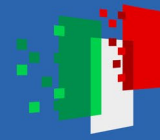

## Physical Behaviour Transition Analysis - Results

$$Q_0 = 2.5 \times 10^{11} \frac{W}{m^3}$$

### Voltage

- Value too low for common voltage taps
- Protection system should rely mainly on temperature sensors (i.e. fibreglass)

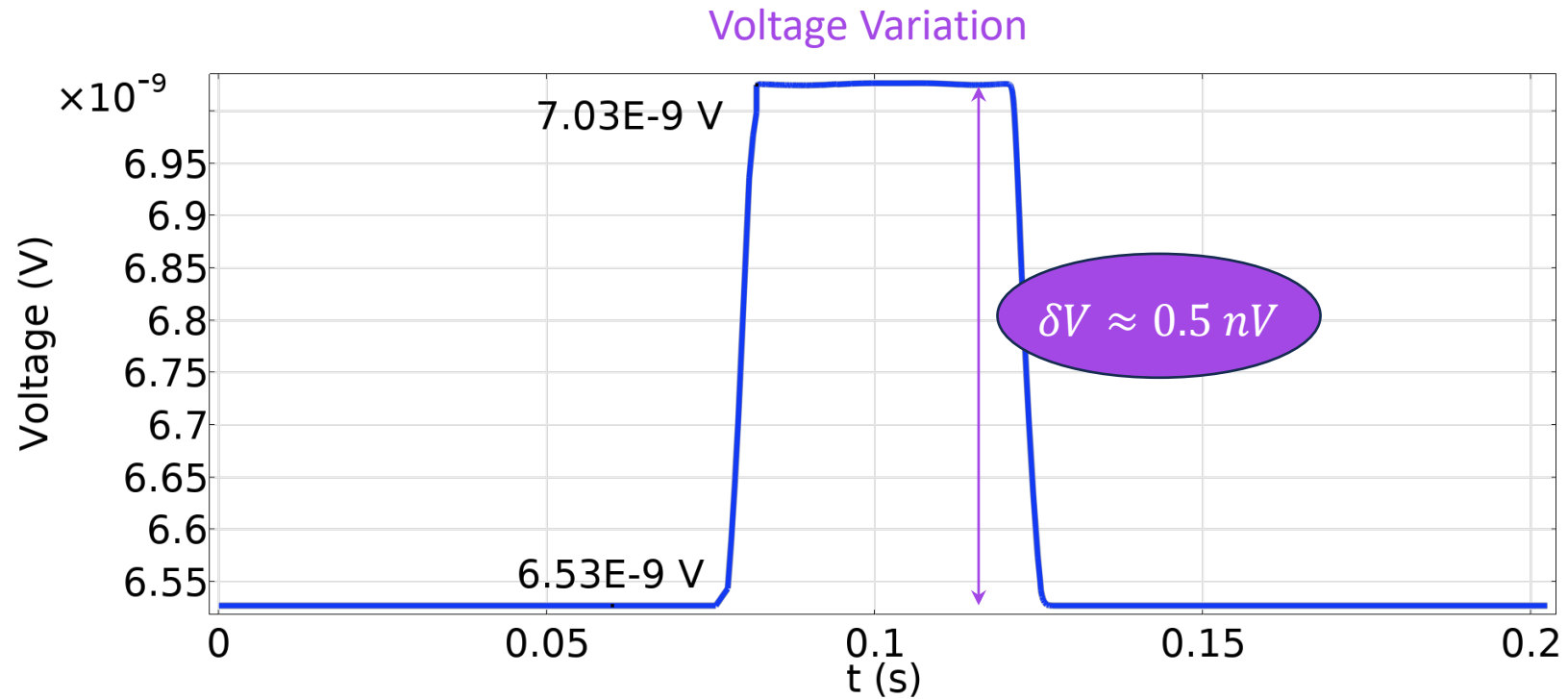

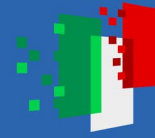

# Physical Behaviour Transition Analysis - Results

$$Q_0 = 3 \times 10^{12} \frac{W}{m^3}$$

The cable recover after the transition  
No thermal runaway

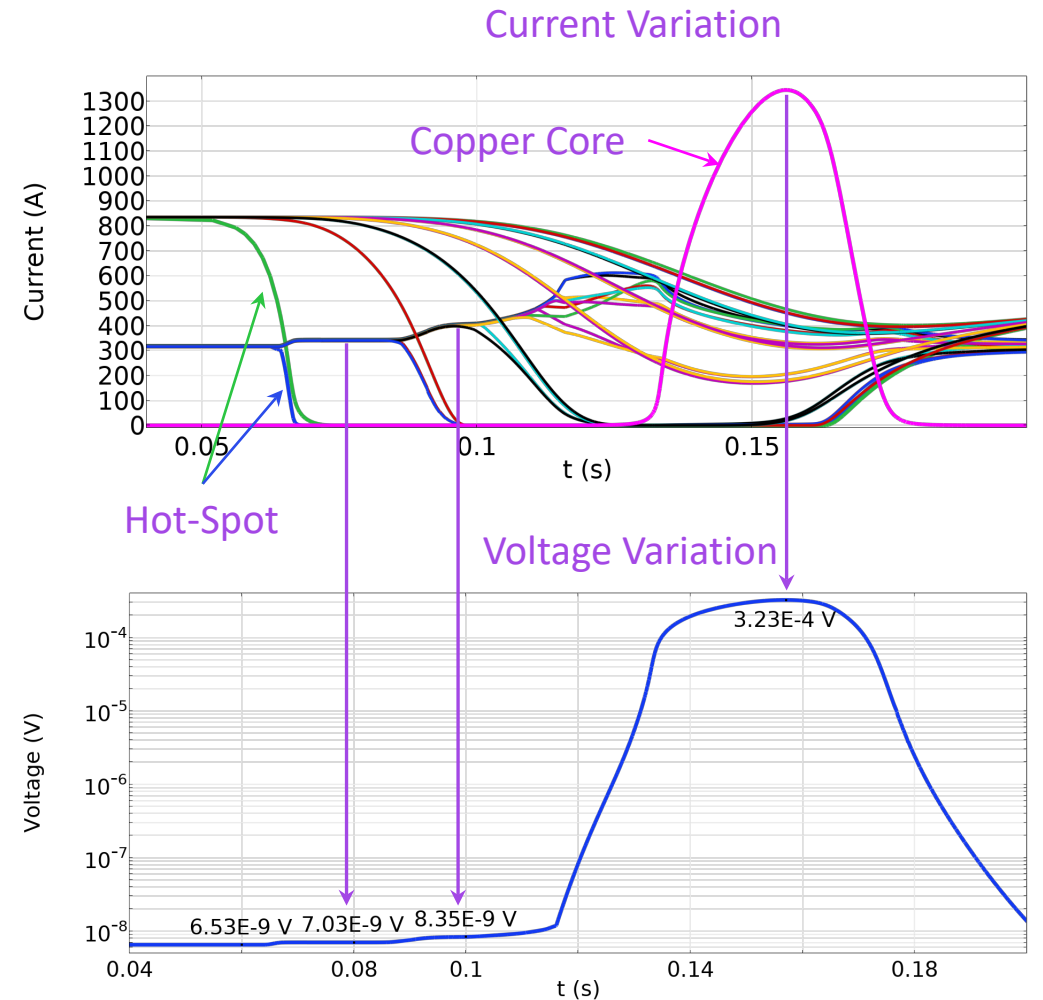
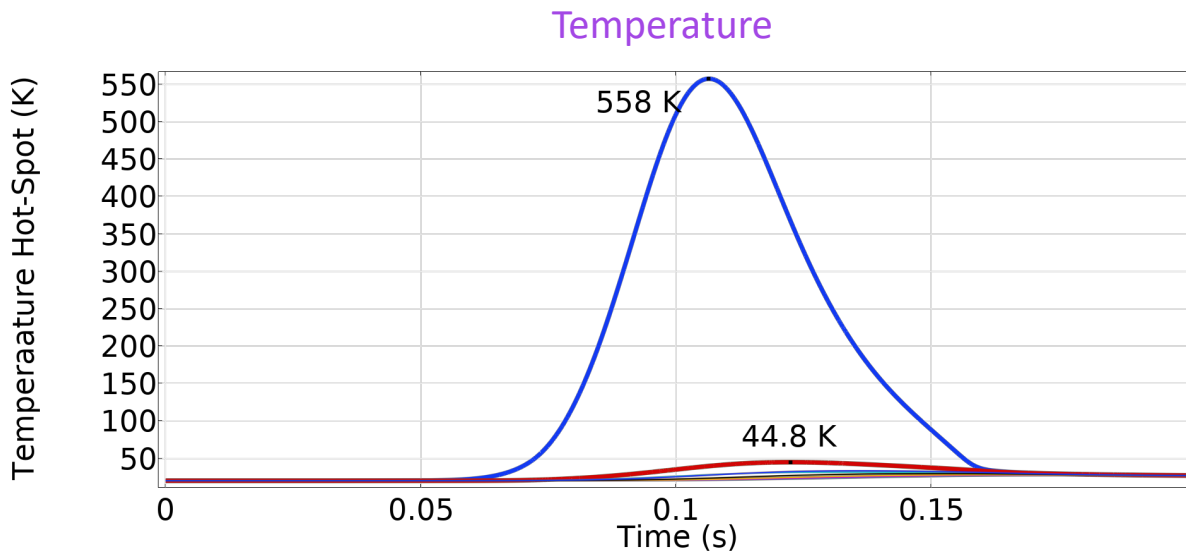



Finanziato  
dall'Unione europea  
NextGenerationEU



Ministero  
dell'Università  
e della Ricerca

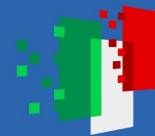

Italiadomani  
PIANO NAZIONALE  
DI RIPRESA E RESILIENZA



# Power Consumption and Use Cases



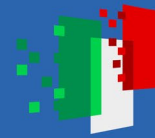

# Power Consumption and Use Cases

## GSL Electric Consumption

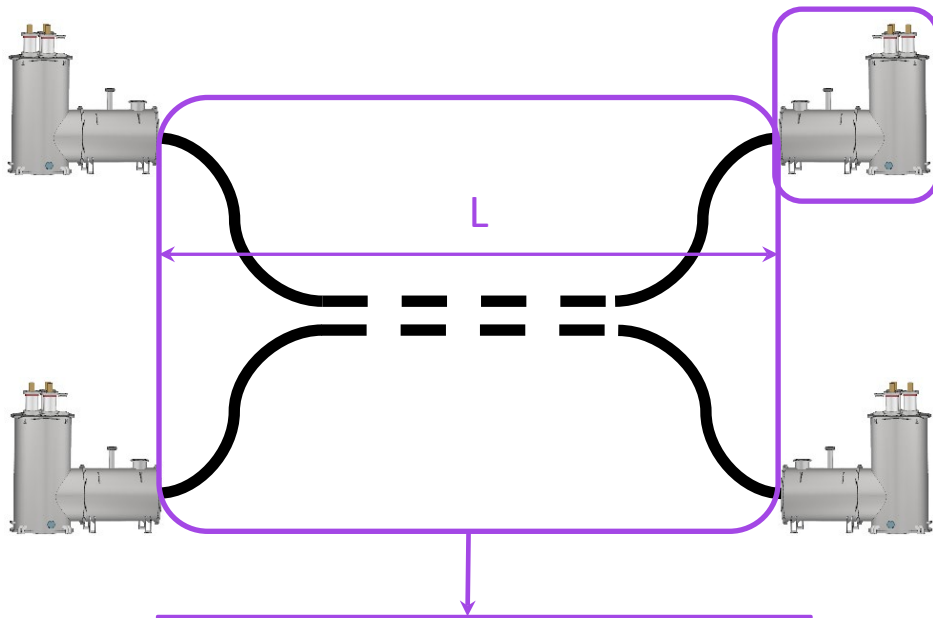

### Current Lead

- Cooling hot stage LN<sub>2</sub>:  $P_{ch} = 400$  W (single module,  $I_{max} = 15$  kA)
- Cooling cold stage He gas:  $P_{cc} = 75$  W
- Total electric:  $P_{cel} = 3 \frac{I}{I_{max}} COP_{LN_2}^{-1} P_{ch} + COP_{He}^{-1} P_{cc} \approx 29$  kW
  - $I = 40$  kA,  $COP_{LN_2}^{-1} = 20$ ,  $COP_{He}^{-1} = 100$

### Line

$$P_l = n_{cr} P_{crel} + n_{cl} P_{cel}$$

### Cryostat

- Cooling:  $P_{crc} = 1.5$  W/m
- Total electric:  $P_{crel} = COP_{He}^{-1} L P_{crc}$

L (m)	Power (MW)	Current (kA)	Cryostat	Power Consumption $P_l$			
				kW	%	W/MW	W/MW/km
130	1000	40	2	155	0.015	155	1190
1000	1000	40	2	415	0.041	415	415

For longer lines the power consumption due to the cryostat becomes the relevant component



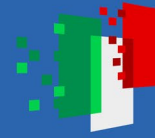

## Power Consumption and Use Cases HVDC Comparative Analysis



Case	Power (MW)	Voltage (kV)	Power Consumption		
			kW	%	W/MW
SA.PE.I.	1000	1000	47.3	0.005	47.3
SuedLink	2000	1050	51.8	0.002	25.9
GSL IRIS	1000	25	415	0.04	415
GSL (1x0.5 W/m)	1000	25	165	0.016	165

### SuedLink

Length: 540 km  
Power: 2000 MW  
Voltage: ±525 kV

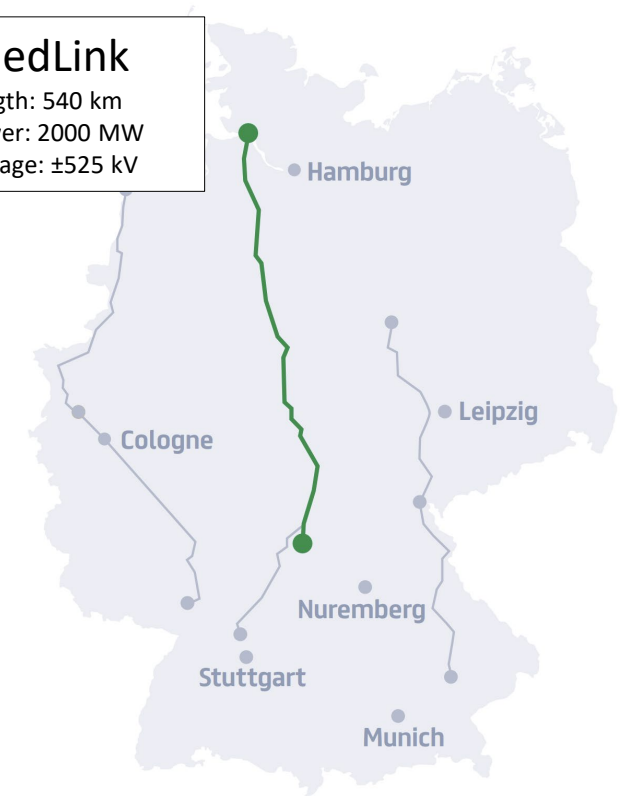

Can be lowered with a **more efficient cryostat** to obtain W/MW in the same range of the showed HVDC



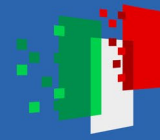

# Power Consumption and Use Cases

## Modular Composition

Full configuration

200 MW

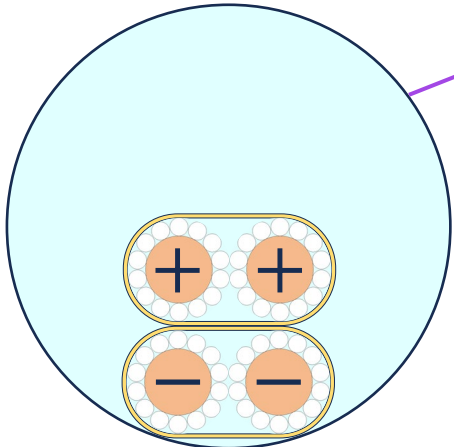

L (m)	Power (MW)	Current (kA)	Cryostat	Power Consumption		
				kW	%	W/MW
1000	1000	40	2	415	0.041	415
1000	200	8	1	197	0.098	985
1000	2	0.08	1	180	9	90k

SURE  
LNF Data Centre

2 MW

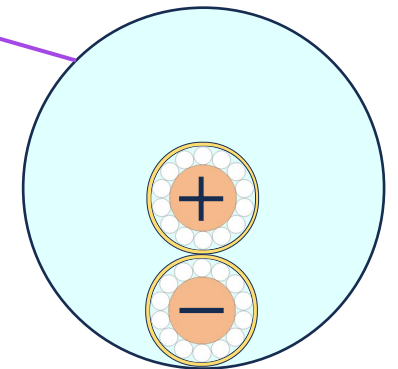

Since the consumption depends on the cryostat losses, **Higher Power** means **lower consumption**

More suitable for **high power application**



# Power Consumption and Use Cases FCC Grid Connection Example

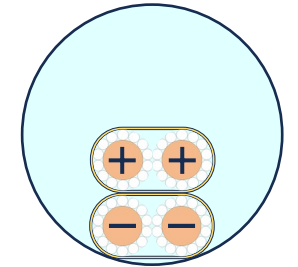
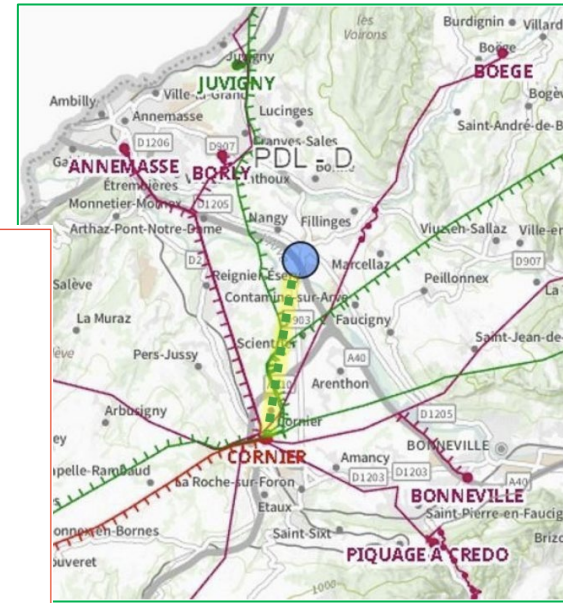
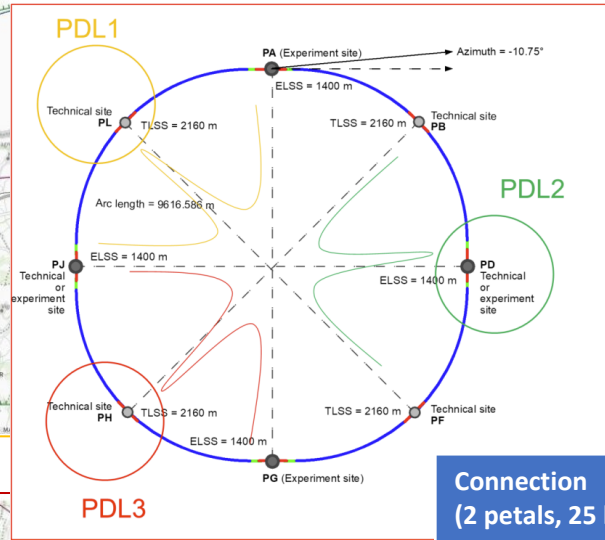
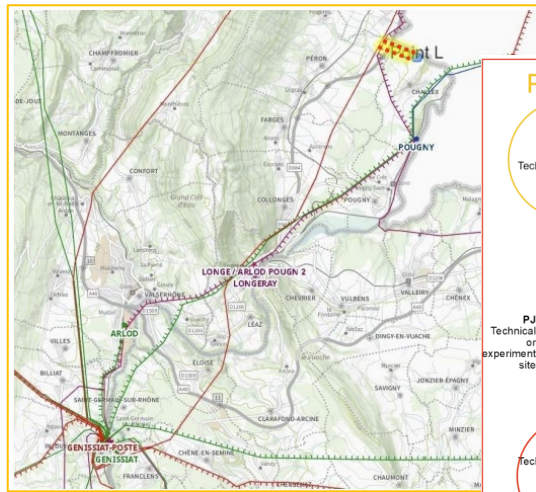

The cooling can be integrated in the existing cooling plants

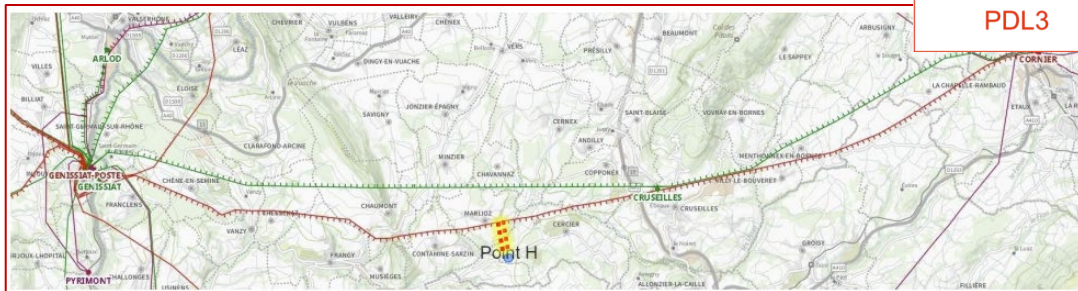

Connection (2 petals, 25 kV, 0.5 W/m)	L (km)	Power (MW)	Cooling Systems (every 1.5 km)	Power Consumption		
				kW	%	W/M W
CORNIER-GENISSIAT - PH	1.6	220	1	88	0.04	400
BOIS-TOLLOT-GENISSIAT - PL	1.5	200	1	308	0.04	415
CORNIER - PD (redundancy)	11	220	7	558	0.25	2540
CERN internal (i.e. magnets)	30	200	20	1510	0.75	7540



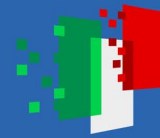

## Power Consumption and Use Cases HVDC Comparative Analysis

Power Station (200 MW) (size estimation)

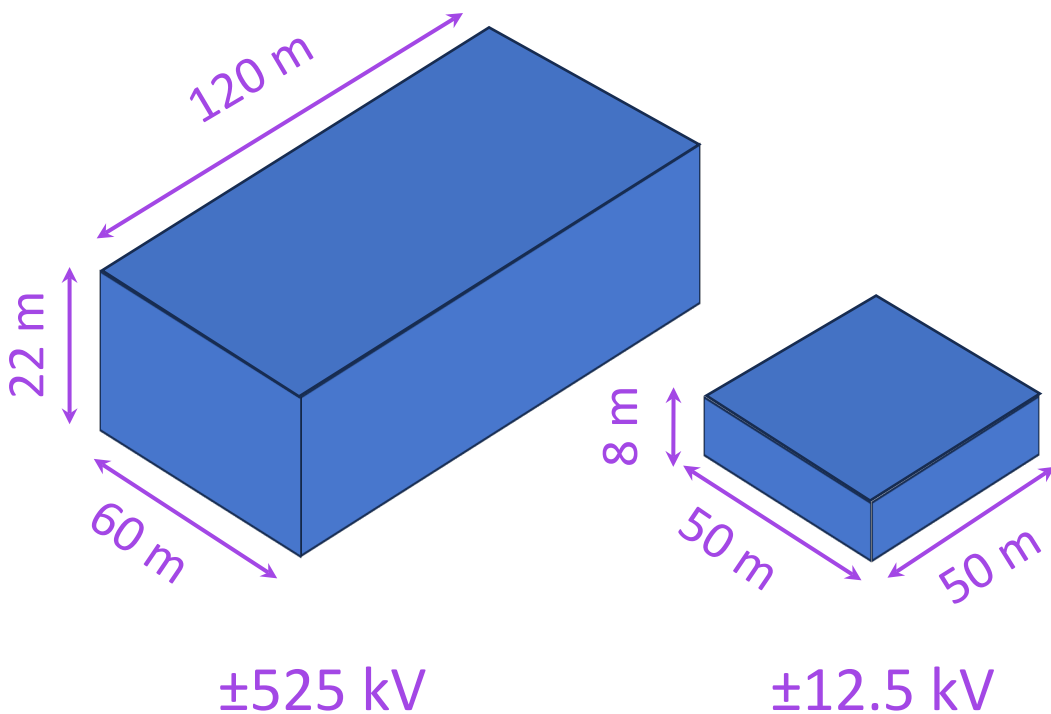

HVDC: lower consumption

IRIS GSL:

- lower voltage (less complex and less vulnerable)
- higher power density (retrofit, urban areas, accelerator facilities and data centres)

Conductor Coss-section Area



SA.PE.I.



IRIS GSL

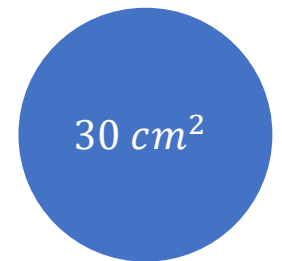

SuedLink

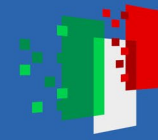

# Power Consumption and Use Cases

## Double Energy Vector

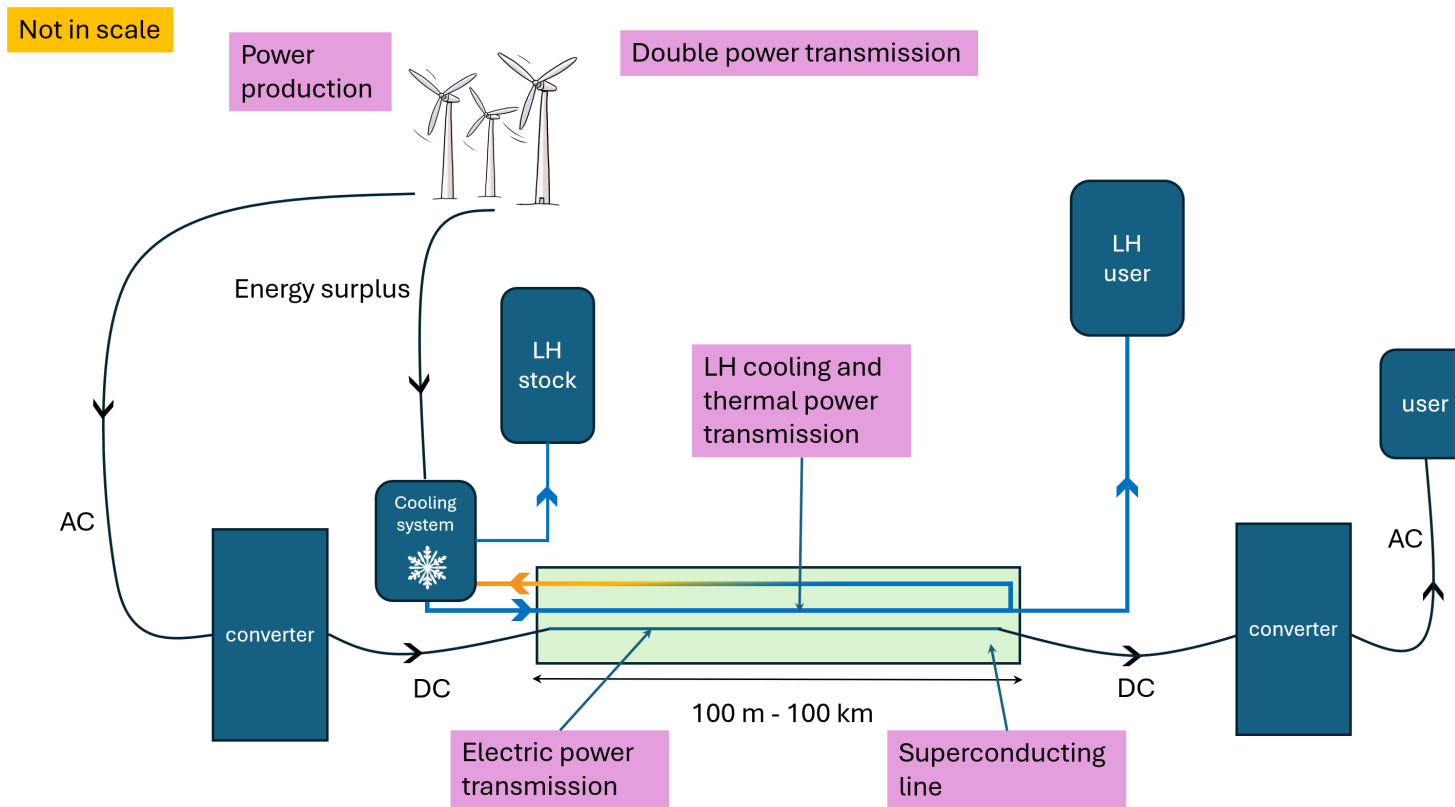



Finanziato  
dall'Unione europea  
NextGenerationEU



Ministero  
dell'Università  
e della Ricerca

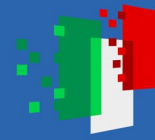

Italiadomani  
PIANO NAZIONALE  
DI RIPRESA E RESILIENZA



# Conclusion

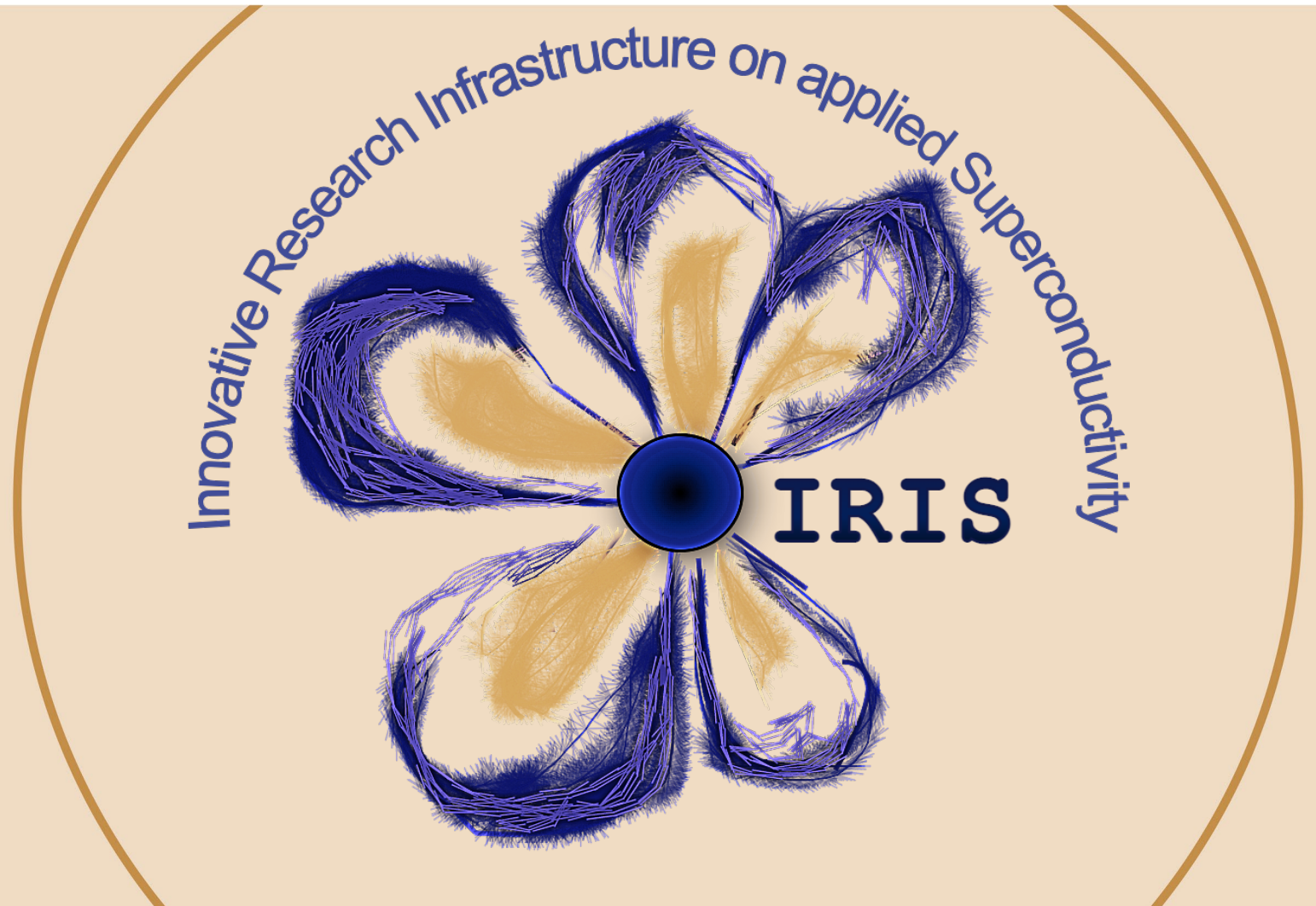

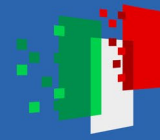

## Conclusion

### Pros

- **Robust** to electrical failure. Potential failures are more likely to originate in the cooling system; such faults are typically **slower** and are consequently easier to detect and assess (fibreglass detection).
- Capable of carrying **much larger currents than conventional conductors** (e.g. 40 kA vs.  $\sim 1$  kA). Useful to powering **accelerator magnets and data centres**.
- Operates at **substantially lower voltages** (e.g. 25 kV vs.  $\sim 1000$  kV), reducing the **size and complexity of voltage-conversion** equipment.
- Offers **higher power density**, requiring **less land take** (urban areas, accelerator and data centres) and can **be installed within existing HVDC trenches to upgrade transmission capacity** (retrofit) without major enlargement of civil works.
- May serve a dual function if cooled with **liquid hydrogen**: electrical transmission combined with **integrated energy storage and free cooling**, enabling novel system architectures in an eventually hydrogen dominated society.

### Cons

- Because the losses depend primarily on the cryostat, the technology may be **uneconomical for medium–low transmitted powers**.
- For distances greater than 1.5 km, **multiple cooling stations are required** in the most favourable (best-case) scenario. An alternative is the use of higher-pressure cooling systems.
- It is not always advantageous: in some cases, the electrical power required for refrigeration exceeds the Joule losses saved. However, this can be reduced with optimised—albeit typically more expensive—cooling plants.

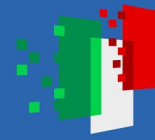

## Conclusion

The **IRIS Green Superconducting Line** can represent a valid alternative to conventional HVDC systems for **specific applications**. Its suitability depends on the overall system context: it is particularly advantageous where **very high currents and powers** are required, where **cryogenic infrastructure is already available**, or where **spatial and civil-engineering constraints** make compact, high-power links desirable. The analyses are conducted under conservative assumptions, with **improving margins**.



Finanziato  
dall'Unione europea  
NextGenerationEU



Ministero  
dell'Università  
e della Ricerca

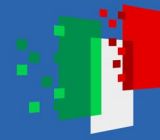

Italiadomani  
PIANO NAZIONALE  
DI RIPRESA E RESILIENZA



## The End

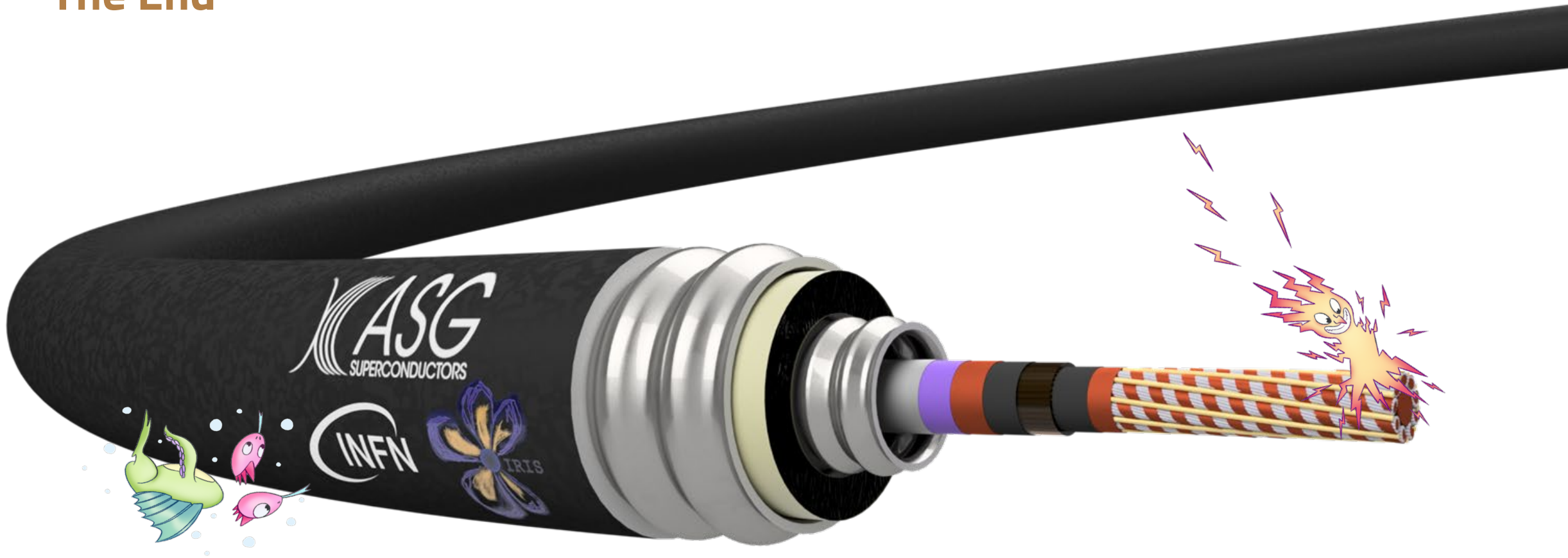



Finanziato  
dall'Unione europea  
NextGenerationEU



Ministero  
dell'Università  
e della Ricerca

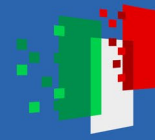

Italiadomani  
PIANO NAZIONALE  
DI RIPRESA E RESILIENZA



# Backup

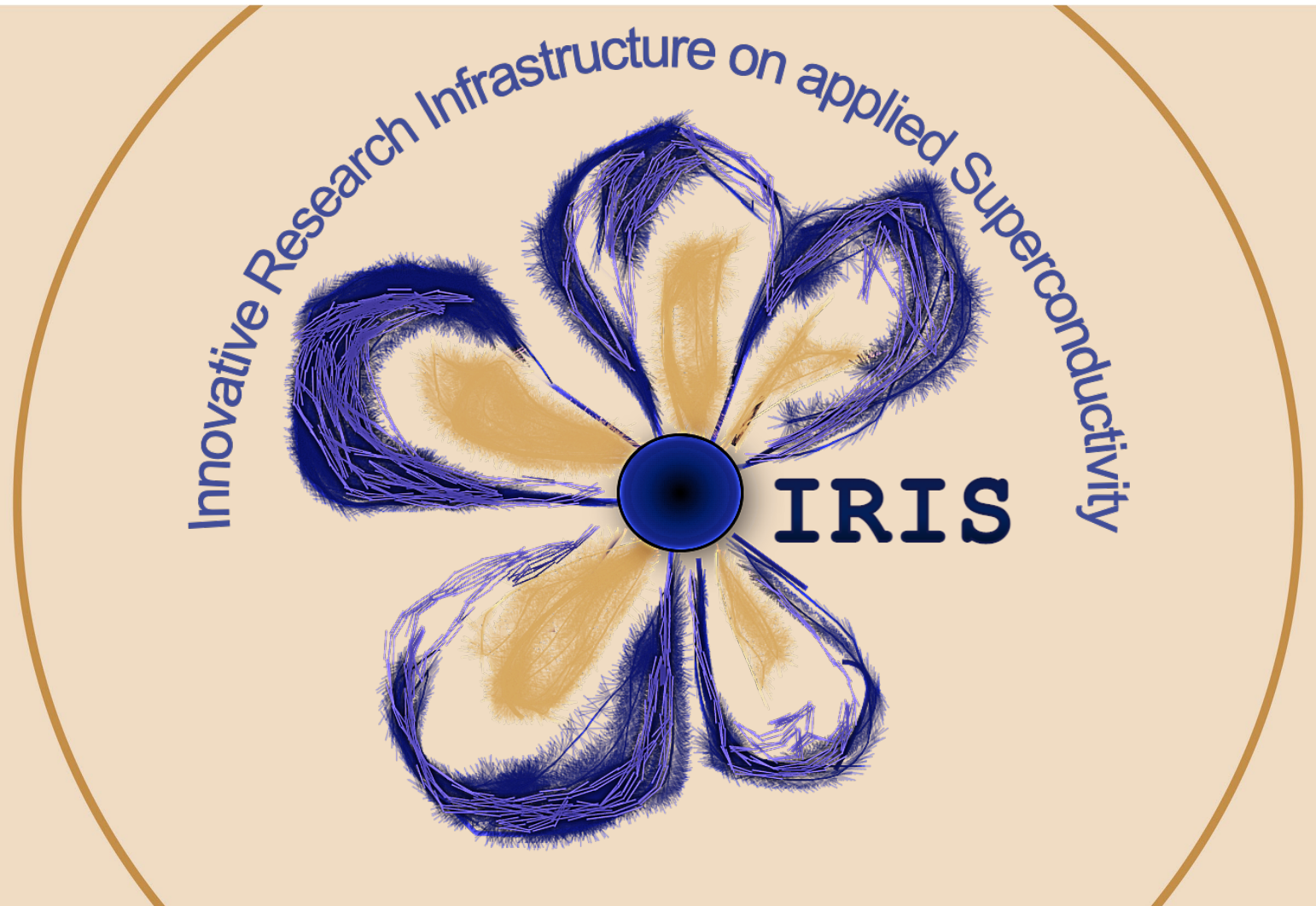

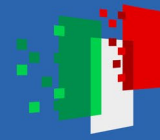

# Critical Current - Data interpolation

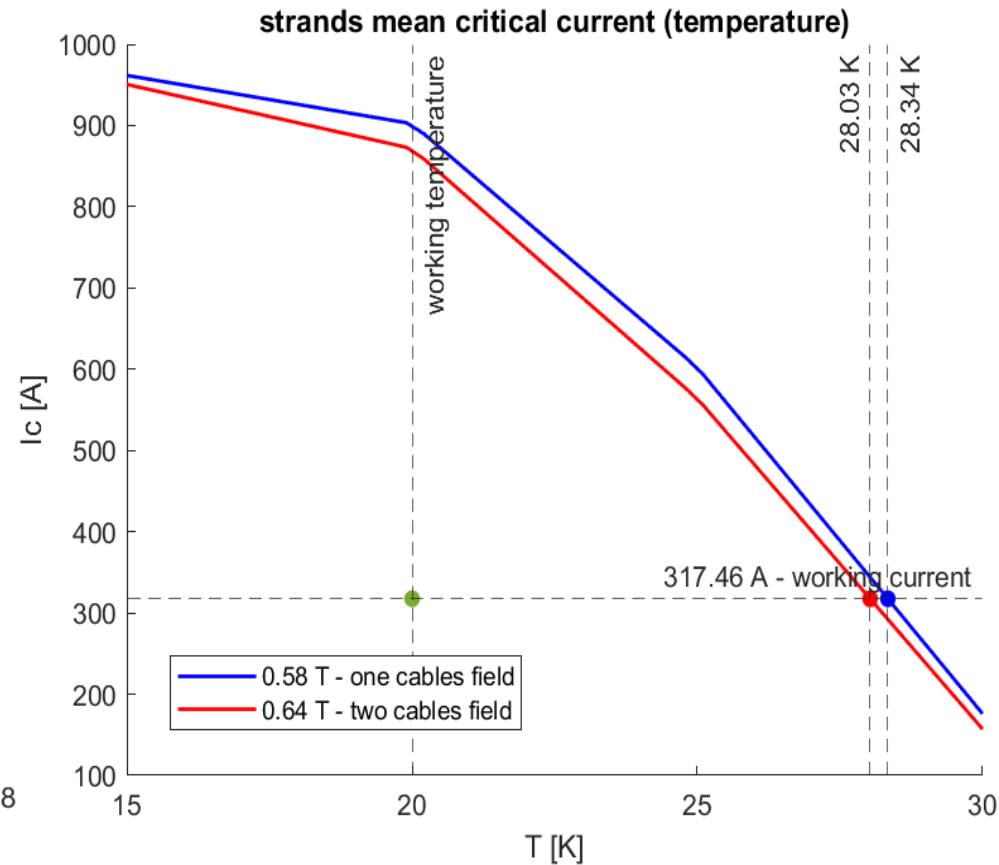
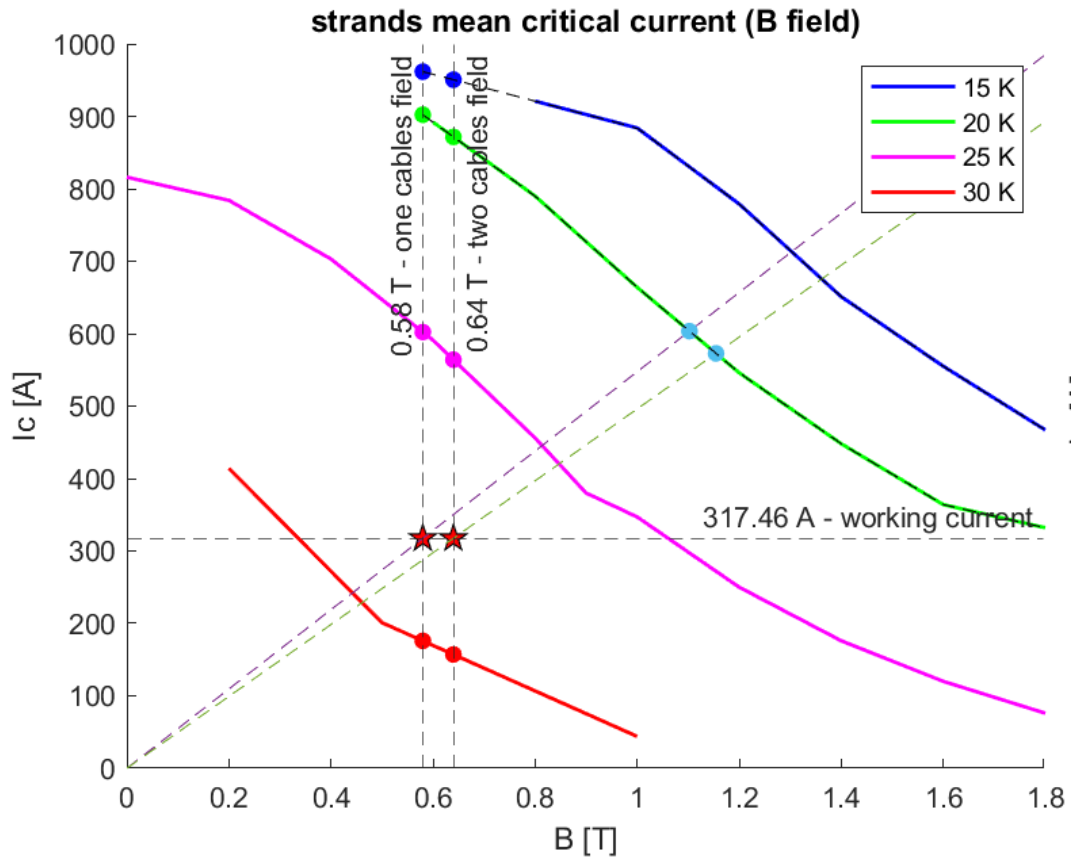

One cable  
 $\Delta T = 8.34 K$

Two cables  
 $\Delta T = 8.03 K$



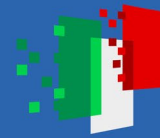

## Temperature Margines

Operative current for single strand

$$I_s = \frac{40 \text{ kA}}{9 * 14} \approx 317.46 \text{ A}$$

From FIT  $\Delta T_{0.58T} \approx 8.29 \text{ K}$

$\Delta T_{0.71T} \approx 7.41 \text{ K}$

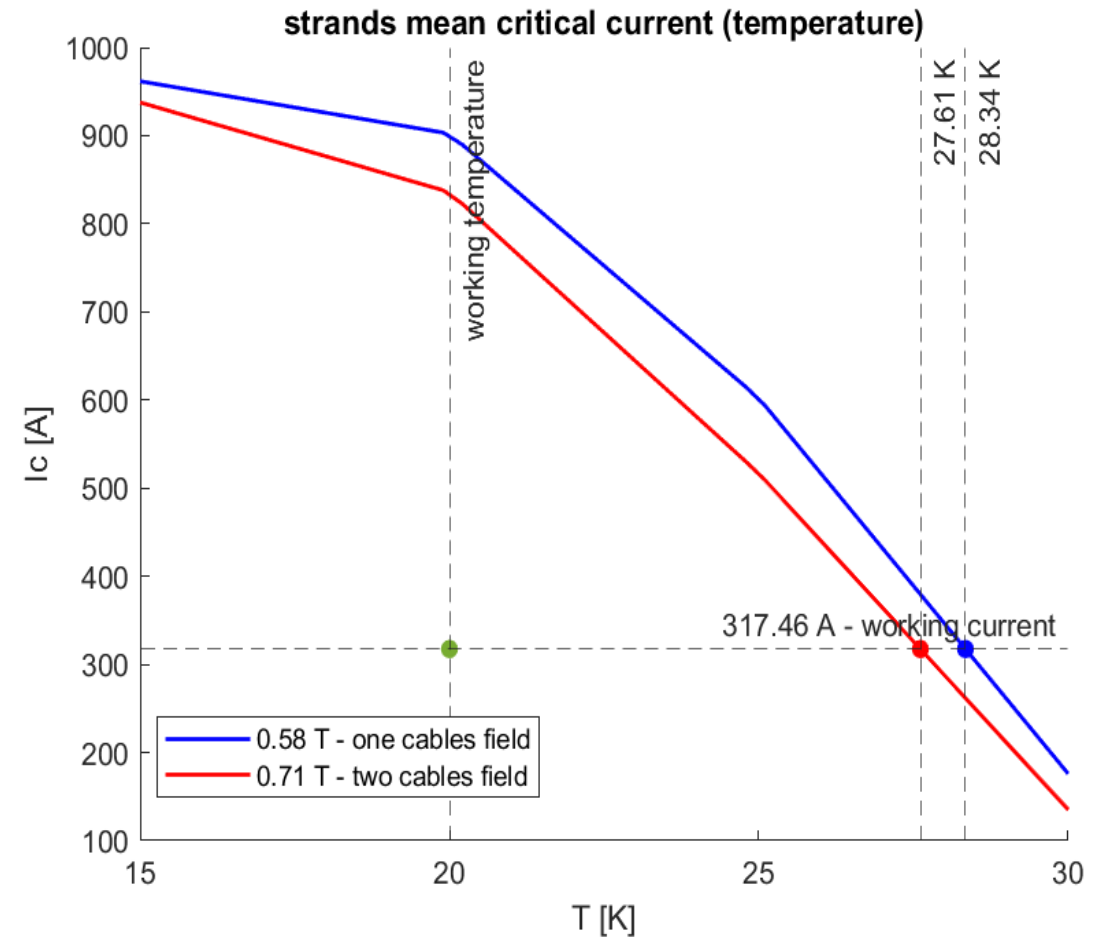



Finanziato  
dall'Unione europea  
NextGenerationEU



Ministero  
dell'Università  
e della Ricerca

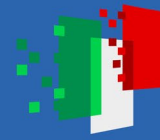

Italiadomani  
PIANO NAZIONALE  
DI RIPRESA E RESILIENZA

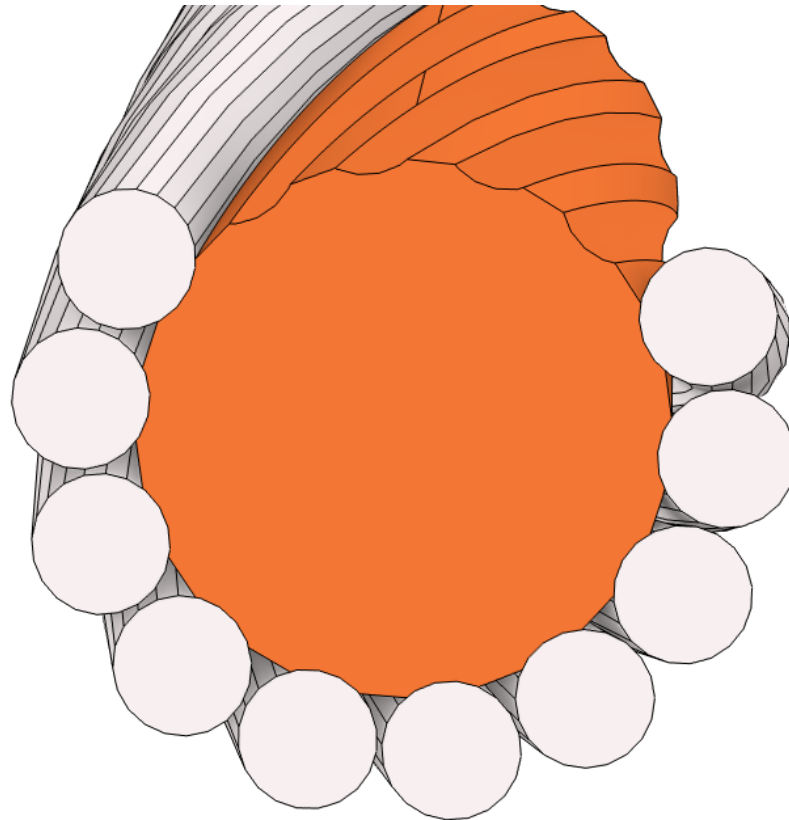

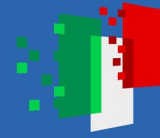

# Cooling Systems

**PRESSURE and TEMPERATURE** of helium as function of position  $x$ , parametrized on mass flow rate  $Q$  in kg/s  
 $P(x=0) = 10 \text{ bar}$ ,  $T(x=0) = 18 \text{ K}$   $P_{\text{loss}} = 0.5 \text{ W/m}$

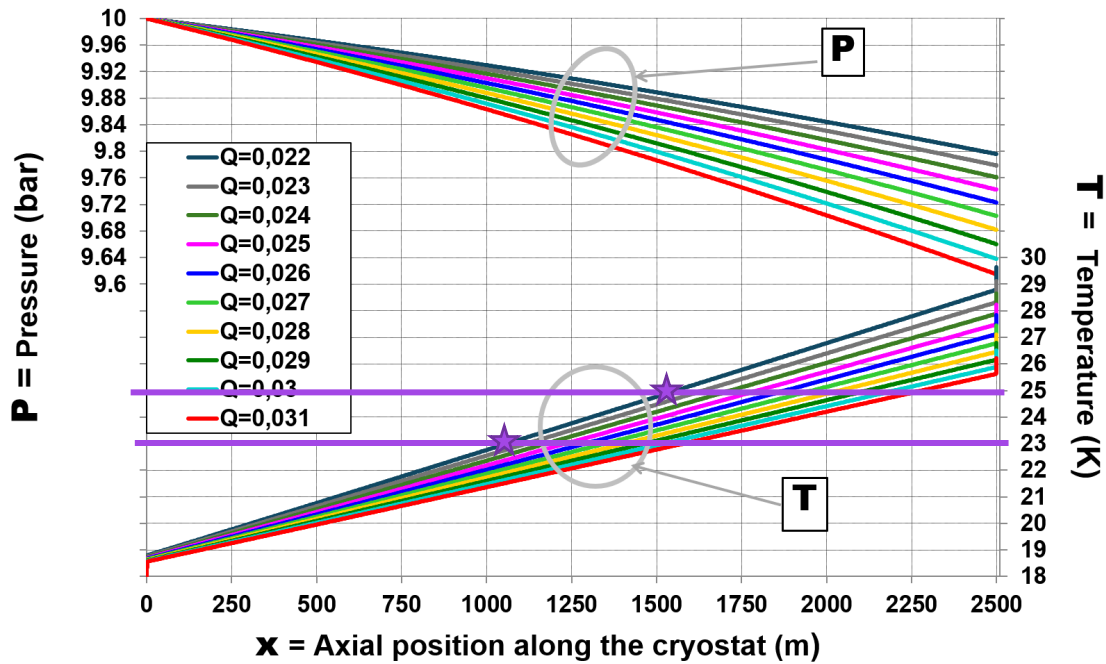

**PRESSURE and TEMPERATURE** of helium as function of position  $x$ , parametrized on mass flow rate  $Q$  in kg/s  
 $P(x=0) = 10 \text{ bar}$ ,  $T(x=0) = 18 \text{ K}$   $P_{\text{loss}} = 1.5 \text{ W/m}$

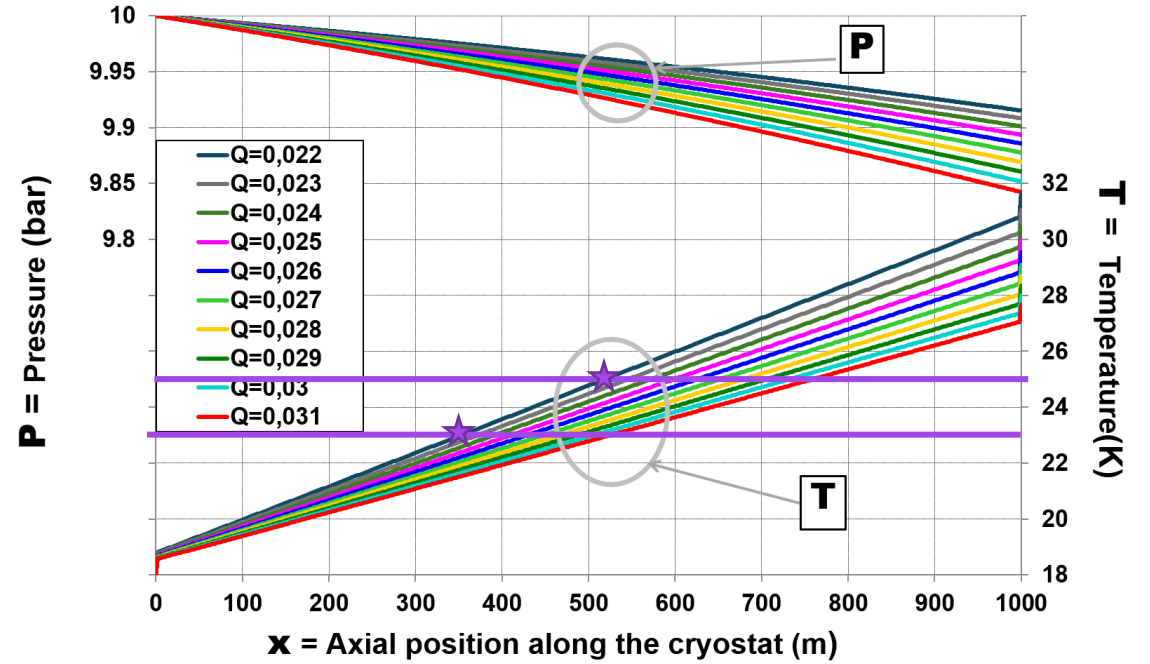

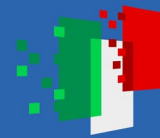

# Cable Geometry Mathematical Model - CGMM

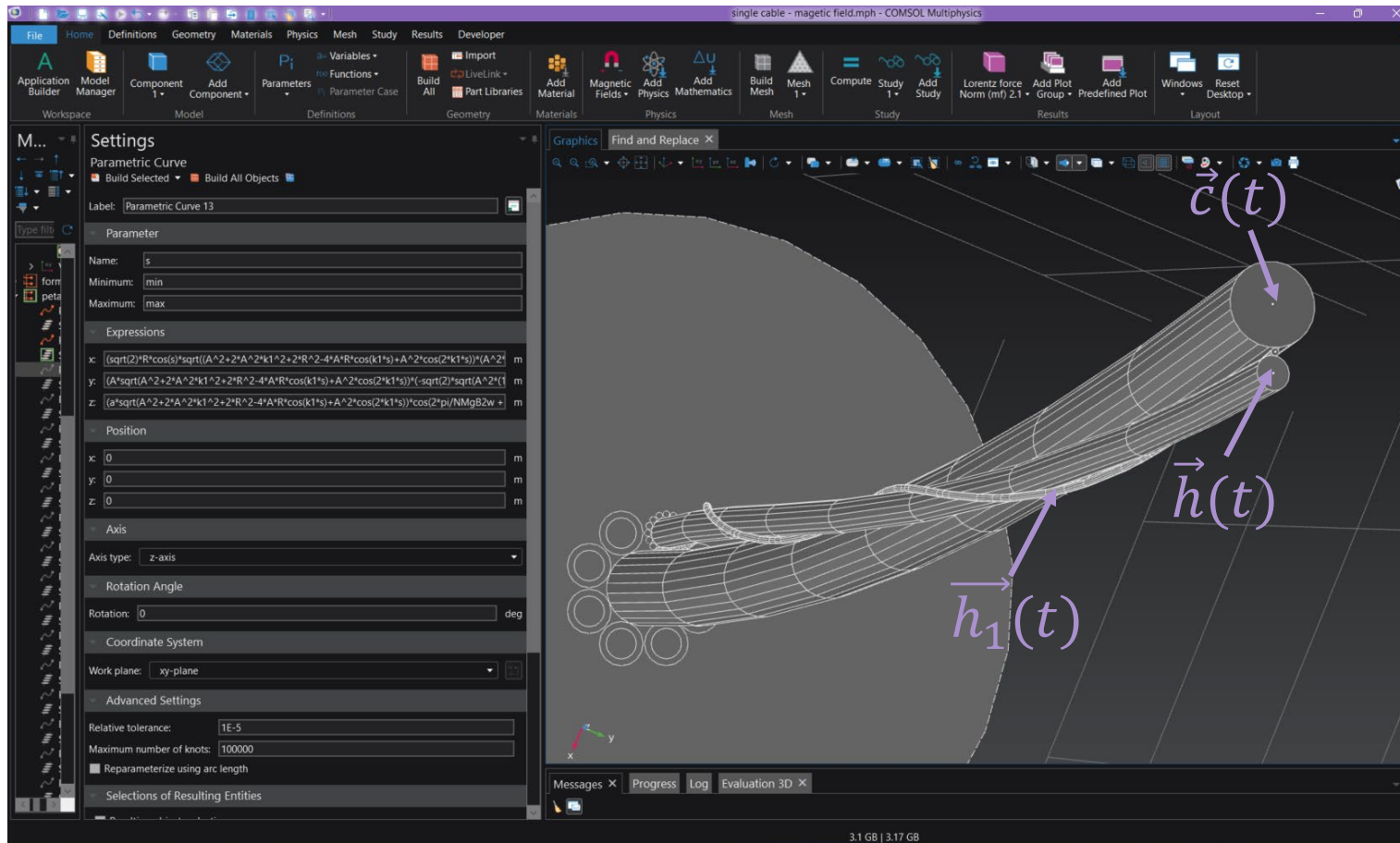

- $\vec{c}(t)$  is an arc of circumference with length  $L_c = 0.5 \text{ m}$  and curvature radius  $R = 2.2 \text{ m}$ , to simulate the minimum required bending of the cable, and  $t \in \left[0, \frac{L}{R}\right]$
- $\vec{h}(t)$  is an helix looping around  $\vec{c}(t)$ , with radius given by the sum of the radius of the cable core plus the radius of the petal core plus the diameter of the strand
- $\vec{h}_1(t)$  is an helix looping around  $\vec{h}(t)$ , with radius given by the sum of the radius of the petal core plus the radius of the strand
- the length  $L_c$  was chosen to have at least two complete loops of the strand around the petal core



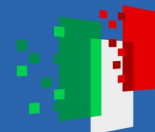

# Cable Geometry Mathematical Model - CGMM

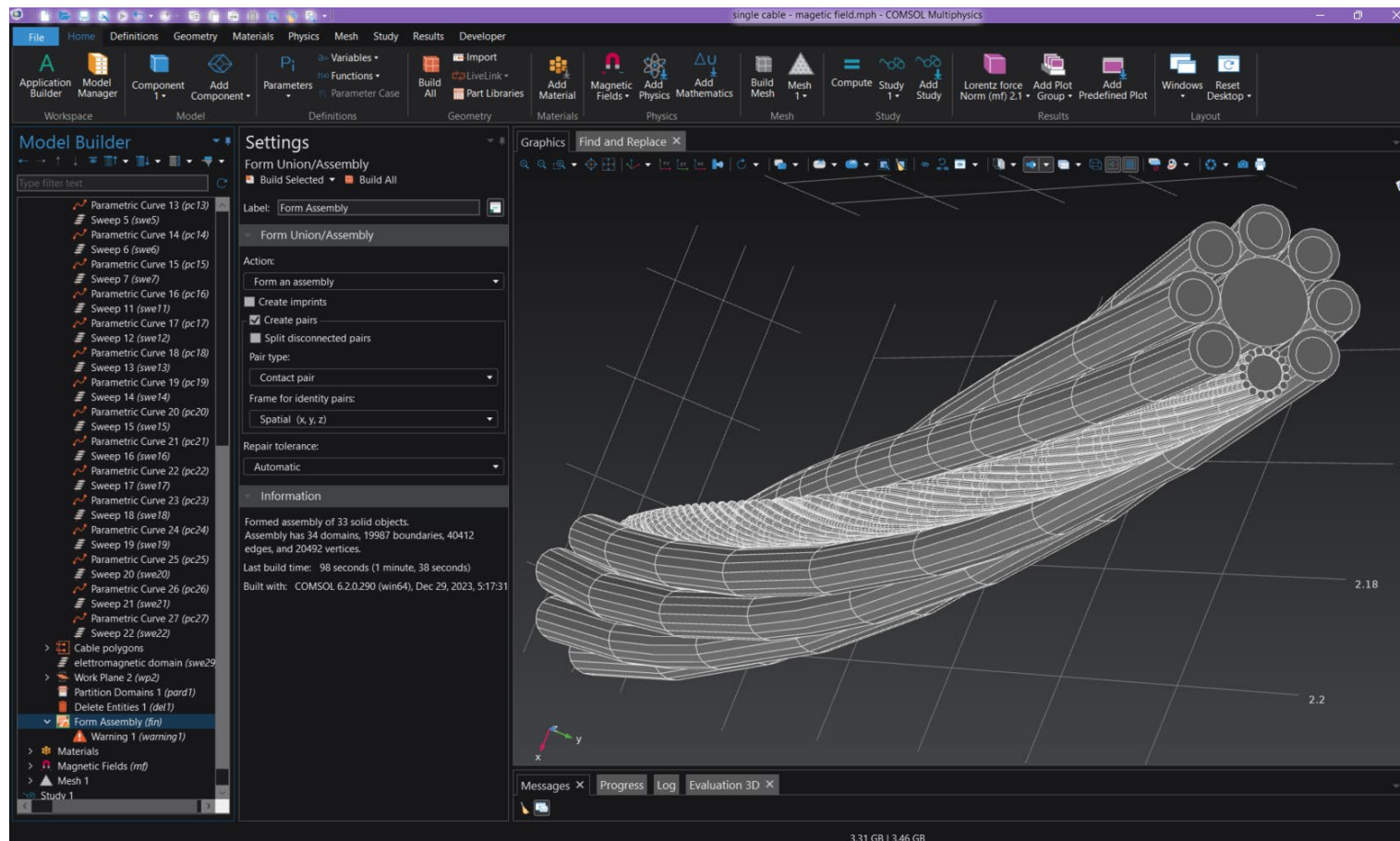

- Every petal has a phase  $\frac{2\pi n}{N_p}$ , where  $N_p$  is the number of petals and  $n \in [0, N_p - 1]$
- Every strand has a phase  $\frac{2\pi n}{N_s}$ , where  $N_s$  is the number of strands and  $n \in [0, N_s - 1]$

This is a critical point when it comes to fully automating the model, because even though it's possible to parameterise the number of petals, I haven't yet found a way to avoid doing all the sweeps manually





## Cable Geometry Mathematical Model - CGMM

- A twisted cable can be parametrised as a helix that goes around a core
- The core itself can be described as a curve, e.g. a helix

The generic form of a helix around a curve  $\vec{c}(t)$  is:

$$\vec{h}(t, \theta) = \vec{c}(t) + A \cos(\theta) \hat{n}(t) + A \sin(\theta) \hat{b}(t)$$

Where:

- $A$  is the radius of the helix
- $\hat{n}(t)$  is the normal unit vector and  $\vec{b}(t)$  is the binormal unit vector of  $\vec{c}(t)$
- $\hat{n}(t)$  and  $\hat{b}(t)$  describe the plane orthogonal to  $\vec{c}(t)$
- Setting  $\theta = k t$  we have that  $\vec{h}(t, \theta)$  loops  $k$ -times around  $\vec{c}(t)$

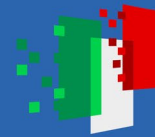

## Cable Geometry Mathematical Model - CGMM

In cartesian coordinates useful for design in Comsol/Inventor

$$\vec{h}(t) = \begin{cases} h_x(t) = c_x(t) + A \cos(kt) n_x(t) + A \sin(kt) b_x(t) \\ h_y(t) = c_y(t) + A \cos(kt) n_y(t) + A \sin(kt) b_y(t) \\ h_z(t) = c_z(t) + A \cos(kt) n_z(t) + A \sin(kt) b_z(t) \end{cases}$$

Iterating the process, one can write a helix that goes around  $\vec{h}(t)$  as:

$$\vec{h}_1(t) = \vec{h}(t) + a \cos(k_1 t) \widehat{n}_h(t) + a \sin(k_1 t) \widehat{b}_h(t)$$

Where:

- The subscript  $h$  is referred to  $\vec{h}(t)$
- $k_1$  is the looping times around  $\vec{h}(t)$  and  $A$  is the radius of  $\vec{h}_1(t)$





## Cable Geometry Mathematical Model - CGMM

- $k$  and  $k_1$  are the number of times that the respective helix loops around its core *for one loop of the core itself*, regardless of its length. To relate them to the twist pitches  $tp$ , they should be normalised with respect to the effective core length  $L_c$ .
- In general,  $tp = \frac{L_c}{n}$ , where  $n$  is the number of loops.
- When the effective length of the core is different from the length of one loop  $L_l$ , one should use  $k = \frac{n}{x_L}$ , where  $x_L = \frac{L_c}{L_l}$ .
- The length of the parametrised helix  $\vec{h}(t)$  is given by  $L_h = \int_0^T \left\| \vec{h}'(t) \right\| dt$ , with  $T = 2\pi$  for one loop, or any suitable value when considering not a loop.

