

# Impact of the environmental noise on the cosmological ambition of Virgo and Einstein Telescope

Kick-off Meeting PhD Cycle XLI @ University of Perugia

5/12/2025

Lorenzo Lunghini

Tutors: Dr. Michele Punturo (INFN Perugia)  
Dr. Maria Concetta Tringali (EGO)

[michele.punturo@pg.infn.it](mailto:michele.punturo@pg.infn.it)  
[maria.tringali@ego-gw.it](mailto:maria.tringali@ego-gw.it)



EINSTEIN  
TELESCOPE

EGO VIRGO



A.D. 1308  
unipg  
UNIVERSITÀ DEGLI STUDI  
DI PERUGIA

**Bachelor Degree in Physics**  
"La Sapienza" University of Rome  
Advisor: Dr. Astone Pia



*"Ricerca di onde gravitazionali continue da stelle di neutroni isolate"*

# Curriculum Vitae

## **Bachelor Degree in Physics**

“La Sapienza” University of Rome

Advisor: Dr. Astone Pia



*“Ricerca di onde gravitazionali continue da stelle di neutroni isolate”*



## **Master Degree in Astronomy and Astrophysics**

“La Sapienza” University of Rome

Advisors: Prof. Leaci Paola & Dr. Astone Pia



*“A Doppler-based global correlation method to veto continuous gravitational-wave candidates”*

# Curriculum Vitae

## Bachelor Degree in Physics

“La Sapienza” University of Rome

Advisor: Dr. Astone Pia

*“Ricerca di onde gravitazionali continue da stelle di neutroni isolate”*



## Master Degree in Astronomy and Astrophysics

“La Sapienza” University of Rome

Advisors: Prof. Leaci Paola & Dr. Astone Pia

*“A Doppler-based global correlation method to veto continuous gravitational-wave candidates”*



## Research Grant (Nov 2024 - Ago 2025)

University of Naples “Federico II”

Advisor: Prof. De Rosa Rosario

- Frequency Dependent Squeezing R&D on Einstein-Podolsky-Rosen (EPR) squeezing @ EGO-Virgo 1500W lab
- Commissioning for Quantum Noise Reduction (QNR) of Virgo detector
- Rapid Response Team for LIGO-Virgo-KAGRA collaboration

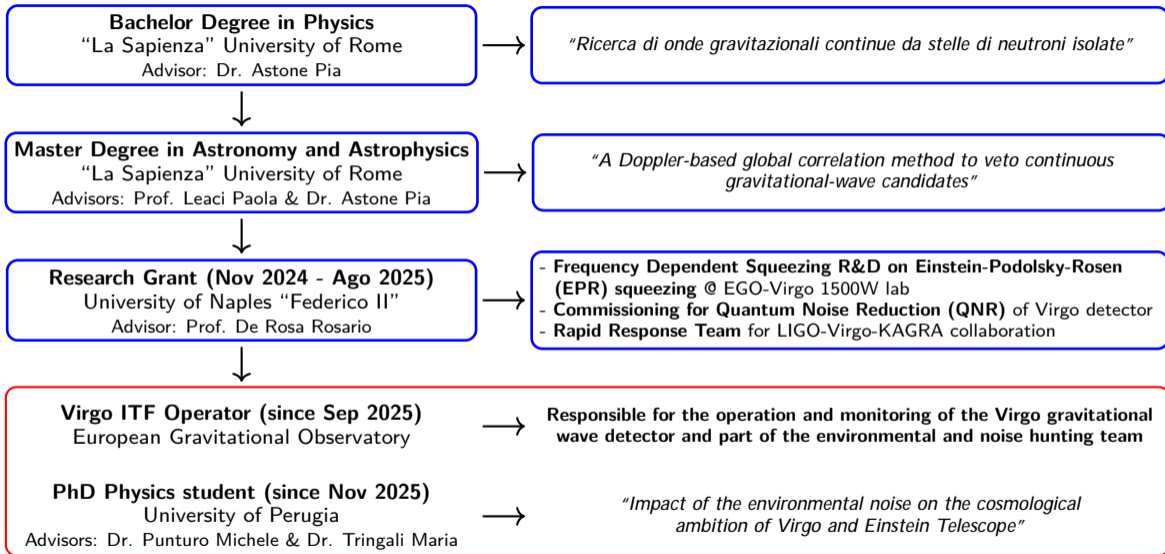

- | **Continuous gravitational waves (CWs):** nearly monochromatic, long-lasting gravitational signals emitted by isolated neutron stars due to non-axisymmetric deformations or r-mode oscillations

[Astone P. *et al.*, **Phys. Rev. D**, vol 4 issue 9, pp 042002–042025, 2014, doi: [10.1103/PhysRevD.90.042002](https://doi.org/10.1103/PhysRevD.90.042002)]

[Antonucci F. *et al.*, **Classical and Quantum Gravity**, vol 25 N 18, pp 184015–184025, 2008, doi: [10.1088/0264-9381/25/18/184015](https://doi.org/10.1088/0264-9381/25/18/184015)]

- | **Continuous gravitational waves (CWs):** nearly monochromatic, long-lasting gravitational signals emitted by isolated neutron stars due to non-axisymmetric deformations or r-mode oscillations
- | Extremely weak amplitudes, often below detector noise, stable frequency evolution, slowly decreasing due to spin-down

[Astone P. *et al.*, **Phys. Rev. D**, vol 4 issue 9, pp 042002–042025, 2014, doi: [10.1103/PhysRevD.90.042002](https://doi.org/10.1103/PhysRevD.90.042002)]

[Antonucci F. *et al.*, **Classical and Quantum Gravity**, vol 25 N 18, pp 184015–184025, 2008, doi: [10.1088/0264-9381/25/18/184015](https://doi.org/10.1088/0264-9381/25/18/184015)]

- | **Continuous gravitational waves (CWs):** nearly monochromatic, long-lasting gravitational signals emitted by isolated neutron stars due to non-axisymmetric deformations or r-mode oscillations
- | Extremely weak amplitudes, often below detector noise, stable frequency evolution, slowly decreasing due to spin-down
- | **Search strategies:**
  - *Targeted:* for known pulsars with precisely measured rotational parameters
  - *Directed:* towards known sky positions with unknown frequency
  - *All-sky:* scan the entire sky over broad frequency bands and spin-down ranges
    - Large parameter space leads to huge computational cost
    - Requires efficient algorithms like Hough transform to extract weak signals from noise

[Astone P. *et al.*, *Phys. Rev. D*, vol 4 issue 9, pp 042002–042025, 2014, doi: [10.1103/PhysRevD.90.042002](https://doi.org/10.1103/PhysRevD.90.042002)]

[Antonucci F. *et al.*, *Classical and Quantum Gravity*, vol 25 N 18, pp 184015–184025, 2008, doi: [10.1088/0264-9381/25/18/184015](https://doi.org/10.1088/0264-9381/25/18/184015)]

- | **Continuous gravitational waves (CWs):** nearly monochromatic, long-lasting gravitational signals emitted by isolated neutron stars due to non-axisymmetric deformations or r-mode oscillations
- | Extremely weak amplitudes, often below detector noise, stable frequency evolution, slowly decreasing due to spin-down
- | **Search strategies:**
  - *Targeted:* for known pulsars with precisely measured rotational parameters
  - *Directed:* towards known sky positions with unknown frequency
  - *All-sky:* scan the entire sky over broad frequency bands and spin-down ranges
    - Large parameter space leads to huge computational cost
    - Requires efficient algorithms like Hough transform to extract weak signals from noise
- | **My work:** *“Ricerca di onde gravitazionali continue da stelle di neutroni isolate”* was about the **Frequency-Hough (FH)** hierarchical pipeline developed by the Virgo group of Rome Sapienza which maps, for each position of a sky grid, time-frequency peaks of the detector data to the source frequency and spin-down plane through the Hough transform

[Astone P. *et al.*, **Phys. Rev. D**, vol 4 issue 9, pp 042002–042025, 2014, doi: [10.1103/PhysRevD.90.042002](https://doi.org/10.1103/PhysRevD.90.042002)]

[Antonucci F. *et al.*, **Classical and Quantum Gravity**, vol 25 N 18, pp 184015–184025, 2008, doi: [10.1088/0264-9381/25/18/184015](https://doi.org/10.1088/0264-9381/25/18/184015)]

- | **All-sky FH pipeline** produces  $O(10^7)$  candidates for  $O(10^2)$  fake signals software added, called **Software Injections (SIs)**, to the data of the observing run O3

- | **All-sky FH pipeline** produces  $O(10^7)$  candidates for  $O(10^2)$  fake signals software added, called **Software Injections (SIs)**, to the data of the observing run O3
- | A CW source, real or injected, located in a certain position in the sky can produce multiple candidates because of the **residual Doppler shift caused by the Earth's motion**

- | **All-sky FH pipeline** produces  $O(10^7)$  candidates for  $O(10^2)$  fake signals software added, called **Software Injections (SIs)**, to the data of the observing run O3
- | A CW source, real or injected, located in a certain position in the sky can produce multiple candidates because of the **residual Doppler shift caused by the Earth's motion**
- | **The implementation of a chain of vetoes** is required to discard candidates produced by the same source in order to reduce the computational cost for the follow-up of the most prominent ones

- | **All-sky FH pipeline** produces  $O(10^7)$  candidates for  $O(10^2)$  fake signals software added, called **Software Injections (SIs)**, to the data of the observing run O3
- | A CW source, real or injected, located in a certain position in the sky can produce multiple candidates because of the **residual Doppler shift caused by the Earth's motion**
- | **The implementation of a chain of vetoes** is required to discard candidates produced by the same source in order to reduce the computational cost for the follow-up of the most prominent ones
- | **My work:** *“A Doppler-based global correlation method to veto continuous gravitational-wave candidates”* was about the testing and the implementation of a Doppler-based global correlation chain of vetoes able to discard exploiting properties of the Hough transform.  
**I added 200 SIs to the O3 data of LIGO Livingston and LIGO Hanford** detectors being able to reduce 80% of the total candidates produced by the FH pipeline

## I Quantum Noise in Gravitational Wave Detectors

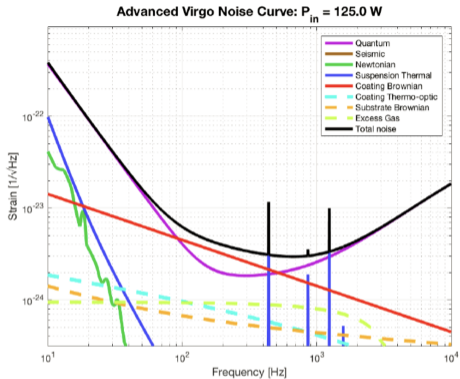

Credit: Sequino V.

## I Quantum Noise in Gravitational Wave Detectors

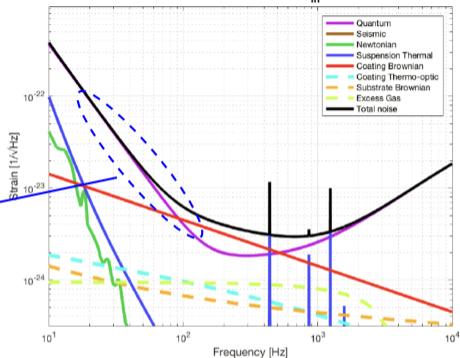
 Advanced Virgo Noise Curve:  $P_{in} = 125.0 \text{ W}$ 

Credit: Sequino V.

## Radiation Pressure Noise (RPN)

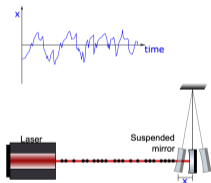

$$S_h^{RPN}(\omega) = \frac{16F}{mL(2\omega)^2} \frac{P_{in}}{c} \frac{1}{1 + (\omega/\omega_p)^2}$$

## I Quantum Noise in Gravitational Wave Detectors

Advanced Virgo Noise Curve:  $P_{in} = 125.0 \text{ W}$

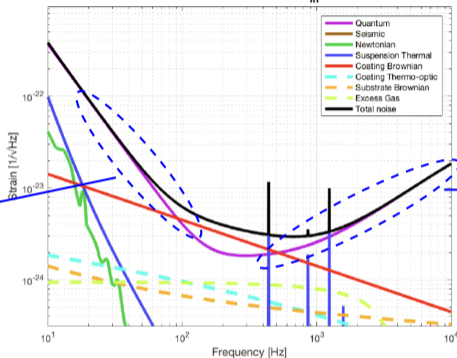

### Radiation Pressure Noise (RPN)

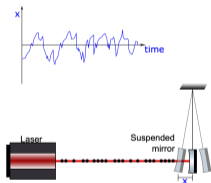

### Shot Noise (SN)

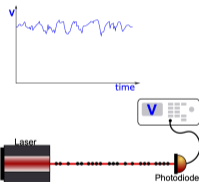

$$S_h^{RPN}(\omega) = \frac{16F}{mL(2\pi)^2} \frac{P_{in}}{c} \frac{1}{1 + (\omega/\omega_p)^2}$$

$$S_h^{SN}(\omega) = \frac{c}{16P_{arms}} \frac{1}{(LF)^2} \left( 1 + \frac{1}{p} \right)$$

I Quantum Noise in Gravitational Wave Detectors

Advanced Virgo Noise Curve:  $P_{in} = 125.0 \text{ W}$

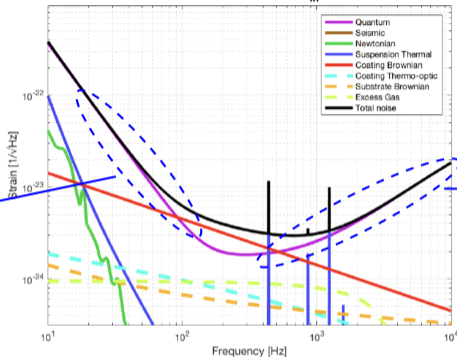

Radiation Pressure Noise (RPN)

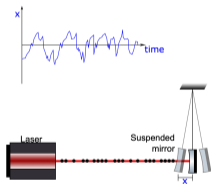

Shot Noise (SN)

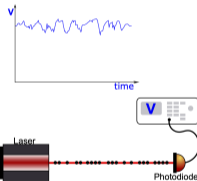

$$S_h^{RPN}(\omega) = \frac{16F}{mL(2\pi)^2} \frac{P_{in}}{c} \frac{1}{1 + (\omega/\rho)^2}$$

$$S_h^{SN}(\omega) = \frac{c}{16P_{arms}} \frac{1}{(LF)^2} \left( 1 + \frac{1}{p} \right)$$

Quantum noise is the uncorrelated sum of RPN and SN

$$S_h^{QN}(\omega) = S_h^{SN}(\omega) + S_h^{RPN}(\omega)$$

## Einstein-Podolsky-Rosen squeezing table-top experiment @ EGO-Virgo 1500W Squeezing Lab

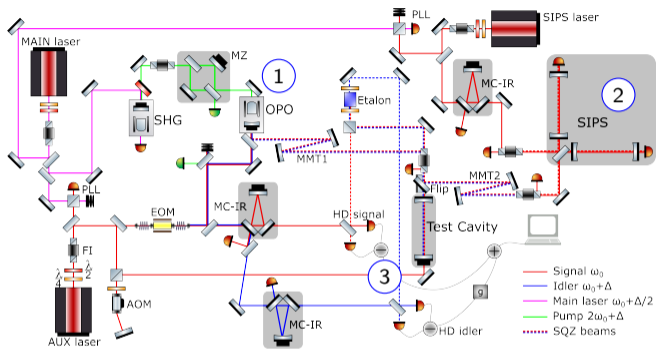

De Marco F., Lunghini L. *et al.*, *NIM A* 1080, 170644 (2025)  
<https://doi.org/10.1016/j.nima.2025.170644>

- 1) Non-Degenerate Optical Parametric Oscillator  
**Signal** and **Idler** entangled states detuned by
- 2) Interferometer arm cavities = frequency filter for **detuned Idler**

Frequency dependent squeezing on entangled states

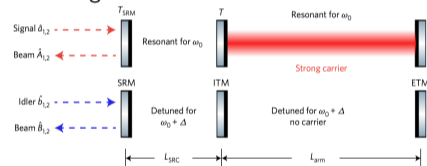

- 3) Squeezing states rotation measurements through 2 balanced homodynes

Einstein-Podolsky-Rosen squeezing table-top experiment @ EGO-Virgo 1500W Squeezing Lab

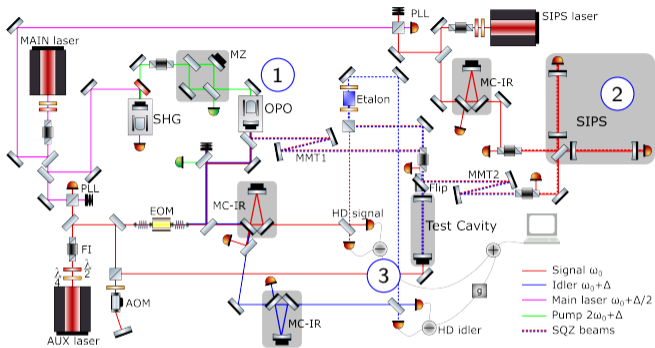

De Marco F., Lunghini L. *et al.*, *NIM A* 1080, 170644 (2025)  
<https://doi.org/10.1016/j.nima.2025.170644>

- 1) Non-Degenerate Optical Parametric Oscillator  
**Signal** and **Idler** entangled states detuned by
- 2) Interferometer arm cavities = frequency filter for **detuned Idler**  
 Frequency dependent squeezing on entangled states

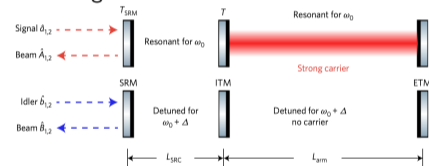

- 3) Squeezing states rotation measurements through 2 balanced homodynes

My work was about: the design and implementation a part of the optical setup, optimization of squeezer pump source (SHG & OPO) and design of custom mechanical parts for optic elements

## Position as Virgo ITF Operator @ European Gravitational Observatory

- | Since September 2025, I started working at European Gravitational Observatory (EGO) as Control Room operator of Virgo interferometer, which is a **Michelson interferometer with 3 km long arms**

## Position as Virgo ITF Operator @ European Gravitational Observatory

- | Since September 2025, I started working at European Gravitational Observatory (EGO) as Control Room operator of Virgo interferometer, which is a **Michelson interferometer with 3 km long arms**
- | The **EGO consortium** is situated in the countryside near Pisa in Italy, is the home of the Virgo gravitational wave detector, it is responsible for ensuring the functioning, maintenance and operation of the Virgo detector, and carries out research in the field of gravitational waves

## Position as Virgo ITF Operator @ European Gravitational Observatory

- | Since September 2025, I started working at European Gravitational Observatory (EGO) as Control Room operator of Virgo interferometer, which is a **Michelson interferometer with 3 km long arms**
- | The **EGO consortium** is situated in the countryside near Pisa in Italy, is the home of the Virgo gravitational wave detector, it is responsible for ensuring the functioning, maintenance and operation of the Virgo detector, and carries out research in the field of gravitational waves
- | The operator duties:
  - **operates and monitors the detector** during observing runs and commissioning
  - **monitors in real time all major subsystems** (e.g. injection, suspensions, vacuum, detection, ...)
  - is the first layer of troubleshooting, spotting unusual behavior of the detector



Aerial view of Virgo

Virgo Control Room

[European Gravitational Observatory site: <https://www.ego-gw.it>]

| *“Impact of the environmental noise on the cosmological ambition of Virgo and Einstein Telescope”*

Tutors: Dr. Michele Punturo (INFN Perugia) [michele.punturo@pg.infn.it](mailto:michele.punturo@pg.infn.it)  
Dr. Maria Concetta Tringali (EGO) [maria.tringali@ego-gw.it](mailto:maria.tringali@ego-gw.it)

| *“Impact of the environmental noise on the cosmological ambition of Virgo and Einstein Telescope”*

Tutors: Dr. Michele Punturo (INFN Perugia) [michele.punturo@pg.infn.it](mailto:michele.punturo@pg.infn.it)  
Dr. Maria Concetta Tringali (EGO) [maria.tringali@ego-gw.it](mailto:maria.tringali@ego-gw.it)

| PhD project conducted under joint supervision between **University of Perugia** and **EGO**

| *“Impact of the environmental noise on the cosmological ambition of Virgo and Einstein Telescope”*

Tutors: Dr. Michele Punturo (INFN Perugia) [michele.punturo@pg.infn.it](mailto:michele.punturo@pg.infn.it)  
Dr. Maria Concetta Tringali (EGO) [maria.tringali@ego-gw.it](mailto:maria.tringali@ego-gw.it)

| PhD project conducted under joint supervision between **University of Perugia** and **EGO**

| Work carried out:

- at **Virgo site in collaboration with EGO Interferometer Department Noise team / Virgo Environmental team**, which studies the impact of environmental noise (acoustic, seismic and electromagnetic) on Virgo interferometer
  
- at **Centro per Applicazioni sulle Onde gravitazionali e la Sismologia (CAOS)** in Perugia where **Einstein Telescope (ET)** class seismic filtering and low-noise control technologies will be developed

- | The **environmental noise** is currently influencing the sensitivity of Virgo, but it will limit the performances of next-generation gravitational-wave detector Einstein Telescope in the 1-100 Hz low frequency band

[Tringali M. C., 2nd Site Preparation Board workshop, [ET-0016A-23](#)]

[Acernese F., *et al.*, *Class. Quantum Grav.*, 39 (2022), 235009, doi: [10.1088/1361-6382/ac776a](https://doi.org/10.1088/1361-6382/ac776a)]

[Virgo logbook entry #67581, <https://logbook.virgo-gw.eu/virgo/?r=67581>]

- | The **environmental noise** is currently influencing the sensitivity of Virgo, but it will limit the performances of next-generation gravitational-wave detector Einstein Telescope in the 1-100 Hz low frequency band
- | The **environmental noise** is made by:

[Tringali M. C., 2nd Site Preparation Board workshop, [ET-0016A-23](#)]

[Acernese F., *et al.*, *Class. Quantum Grav.*, 39 (2022), 235009, doi: [10.1088/1361-6382/ac776a](https://doi.org/10.1088/1361-6382/ac776a)]

[Virgo logbook entry #67581, <https://logbook.virgo-gw.eu/virgo/?r=67581>]

- | The **environmental noise** is currently influencing the sensitivity of Virgo, but it will limit the performances of next-generation gravitational-wave detector Einstein Telescope in the 1-100 Hz low frequency band
- | The **environmental noise** is made by:

## Natural

Sea activity, wind, earthquakes,  
lighting, Earth magnetic field etc

Scattered light glitches correlated with West End  
Suspended Bench (SWEB) motion

[Tringali M. C., 2nd Site Preparation Board workshop, [ET-0016A-23](#)]

[Acernese F., *et al.*, *Class. Quantum Grav.*, 39 (2022), 235009, doi: [10.1088/1361-6382/ac776a](https://doi.org/10.1088/1361-6382/ac776a)]

[Virgo logbook entry #67581, <https://logbook.virgo-gw.eu/virgo/?r=67581>]

- | The **environmental noise** is currently influencing the sensitivity of Virgo, but it will limit the performances of next-generation gravitational-wave detector Einstein Telescope in the 1-100 Hz low frequency band
- | The **environmental noise** is made by:

## Natural

Sea activity, wind, earthquakes, lighting, Earth magnetic field etc

## Anthropogenic

Highways, railway tracks, wind turbine, airplanes, tractors etc

Scattered light glitches correlated with West End Suspended Bench (SWEB) motion

Average variation of the BNS range around its local average, computed on a weekly basis

[Tringali M. C., 2nd Site Preparation Board workshop, [ET-0016A-23](#)]

[Acernese F., *et al.*, *Class. Quantum Grav.*, 39 (2022), 235009, doi: [10.1088/1361-6382/ac776a](#)]

[Virgo logbook entry #67581, <https://logbook.virgo-gw.eu/virgo/?r=67581>]

- | The **environmental noise** is currently influencing the sensitivity of Virgo, but it will limit the performances of next-generation gravitational-wave detector Einstein Telescope in the 1-100 Hz low frequency band
- | The **environmental noise** is made by:

## Natural

Sea activity, wind, earthquakes, lighting, Earth magnetic field etc

## Anthropogenic

Highways, railway tracks, wind turbine, airplanes, tractors etc

## Infrastructural

Air conditioning systems, vacuum devices, electricity, experimental equipment, power supplies etc

Scattered light glitches correlated with West End Suspended Bench (SWEB) motion

Average variation of the BNS range around its local average, computed on a weekly basis

Glitches of power supply of the heating belts of the West Input (WI) tower

[Tringali M. C., 2nd Site Preparation Board workshop, [ET-0016A-23](#)]

[Acernese F., *et al.*, *Class. Quantum Grav.*, 39 (2022), 235009, doi: [10.1088/1361-6382/ac776a](#)]

[Virgo logbook entry #67581, <https://logbook.virgo-gw.eu/virgo/?r=67581>]

## | **Build an environmental noise model of Virgo detector**

- Analyze long-term datasets from seismic, acoustic and magnetic sensor networks installed in the experimental buildings of the Virgo interferometer
- Characterize dominant noise sources (natural, anthropogenic and infrastructure) and their spectral features

## | **Build an environmental noise model of Virgo detector**

- Analyze long-term datasets from seismic, acoustic and magnetic sensor networks installed in the experimental buildings of the Virgo interferometer
- Characterize dominant noise sources (natural, anthropogenic and infrastructure) and their spectral features

## | **Produce a digital model of major environmental noise couplings**

- Model noise propagation and physical coupling processes to Virgo critical detector components
- Use simulation tools like ANSYS to reproduce physical behavior
- Validate the digital model against experimental measurements

## | **Build an environmental noise model of Virgo detector**

- Analyze long-term datasets from seismic, acoustic and magnetic sensor networks installed in the experimental buildings of the Virgo interferometer
- Characterize dominant noise sources (natural, anthropogenic and infrastructure) and their spectral features

## | **Produce a digital model of major environmental noise couplings**

- Model noise propagation and physical coupling processes to Virgo critical detector components
- Use simulation tools like ANSYS to reproduce physical behavior
- Validate the digital model against experimental measurements

## | **Extrapolate noise impact on Einstein Telescope**

- Model noise propagation and physical coupling processes to Virgo critical detector components
- Rescale simulation to Einstein Telescope's design parameters to predict noise effects on the underground ET design
- Support noise mitigation strategies

## | **Build an environmental noise model of Virgo detector**

- Analyze long-term datasets from seismic, acoustic and magnetic sensor networks installed in the experimental buildings of the Virgo interferometer
- Characterize dominant noise sources (natural, anthropogenic and infrastructure) and their spectral features

## | **Produce a digital model of major environmental noise couplings**

- Model noise propagation and physical coupling processes to Virgo critical detector components
- Use simulation tools like ANSYS to reproduce physical behavior
- Validate the digital model against experimental measurements

## | **Extrapolate noise impact on Einstein Telescope**

- Model noise propagation and physical coupling processes to Virgo critical detector components
- Rescale simulation to Einstein Telescope's design parameters to predict noise effects on the underground ET design
- Support noise mitigation strategies

## | **Interface with CAOS research infrastructure**

- Test novel sensing approaches, including distributed acoustic sensing
- Provide input for environmental-noise monitoring and mitigation strategies

## | EDUCATION ACTIVITIES @ PhD Physics course

	YEAR	N. Hours	N. ECTS
Advanced Topics in Multimessenger Astronomy	I	15	2,5
Advanced Topics in Astroparticle Physics	I	15	2,5
Introduction to Quantum Computing	I	18	3
Advanced programming for scientists	I	24	4

## | EDUCATION ACTIVITIES @ other PhD Courses

To be decided

## | Frontal and cross-disciplinary teaching

To be decided

## | Other education activities

	YEAR	Hours/days	N. ECTS
Einstein Telescope science workshop for early career researchers application (18-20 February, 2026, Rome, Italy) (TBC)	I	3 days	1,5
LVK Meeting (9-13 March 2026, Pisa, Italy) (TBC)	I	5 days	2,5

## | Other training activities

To be decided