

**Luminosity monitor detectors
(diamonds)
for high lumi SuperKEKB and
polarimeter**

Task 4.3

Goals of (presently operating) LumiBelle2 fast luminosity monitor

➤ “Dithering” feedback

- Correct for few Hz horizontal motion at IP of SuperKEKB
- 79 Hz orbit “dithering” + luminosity sampling @ 1 kHz → reconstruct baseline freq. + 2nd harmonic
- Efficient separation from other “slow” variations
- **1% relative precision @ 1 kHz** sufficient (cf. Chen-Guo Pang et al., J.Phys.Conf.Ser. 1067 (2018) no.7, 072023)
- Provide analog signal as input to lock-in amplifier

➤ Bunch by bunch luminosity diagnostic

- Nominally 4 ns bunch separation → need **short signal pulses**, ideally < 4 ns
- **1% or better relative precision @ 1 Hz**

➤ IP vertical beam size measurement + tuning **at very low currents**

1. Single beam orbit + optics corrections in two rings
2. Vertical e+ and e- beam size optical tuning → suppress local aberrations in nanobeam final focus

Very low current → avoid confusion from beam-beam induced blowup

3. Control of beam-beam blowup → find best spot in tune diagram

- Dynamic range $L \approx 10^{32} \rightarrow 10^{36} \text{ cm}^{-2} \text{ s}^{-1}$
- Non luminosity scaling contamination < 1% (e.g. beam gas bremsstrahlung and Touschek losses)
- Manage radiation damage at highest luminosity

Bhabha process at vanishing scattering angle

a.k.a. Single Bremsstrahlung

Dima El Khechen et al., PRAB 22, 062801 (2019)

Large cross section $\sigma \approx 150 - 200 \text{ mbarn}$ for $E(\gamma) > 1\% E(\text{beam})$

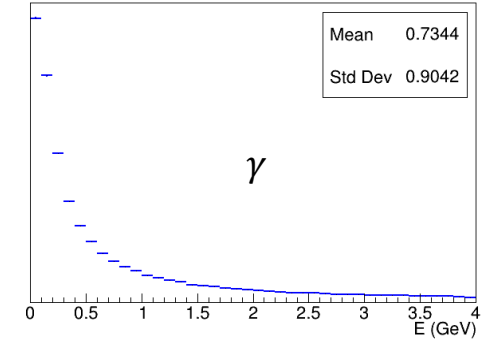
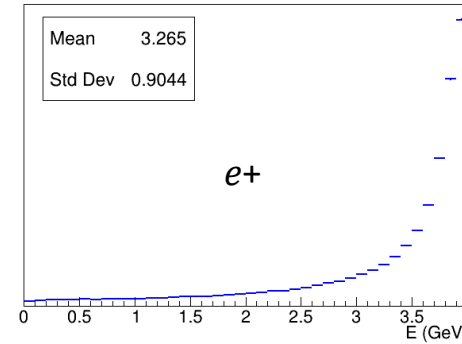
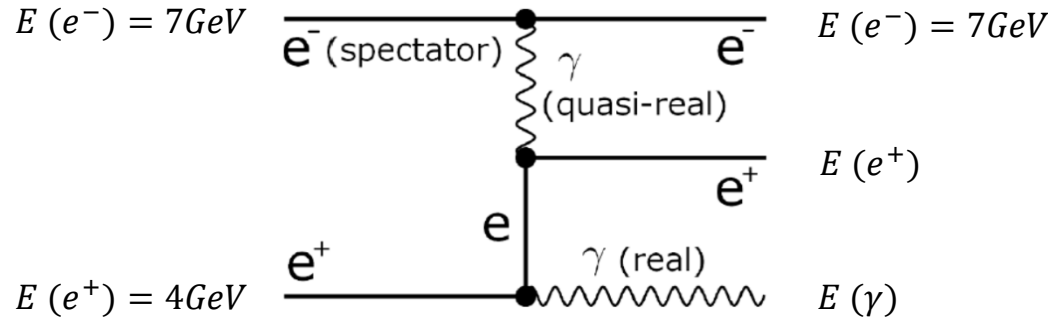

sCVD diamond sensors

High charge carrier mobility \rightarrow fast signal formation
Wide band-gap (5.5 eV) \rightarrow good radiation tolerance

- Monitor bunch-by-bunch luminosity \rightarrow easier with pulse width $< 4 \text{ ns}$
- $140 \mu\text{m}$ thick diamond + fast 2 GHz current amplifier $\rightarrow 2 \text{ ns FWHM}$

SuperKEKB nominal collision spacing = 4 ns

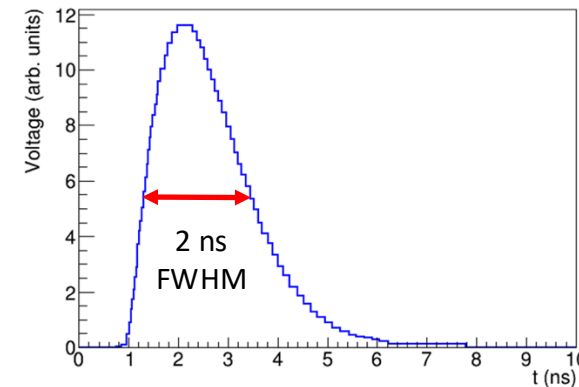

Implementation in LER and HER

Cheng Guo Pang et al., Nucl.Instrum.Meth. A931 (2019) 225-235

POSITRON RING (measure e^+)

- Optimal position found at 10 m behind IP using SAD
- Over-bent Bhabha positrons \rightarrow vacuum chamber
- Special beam pipe with window + Tungsten radiator
- Start-to-end simulation (GuineaPig++, SAD, GEANT4)

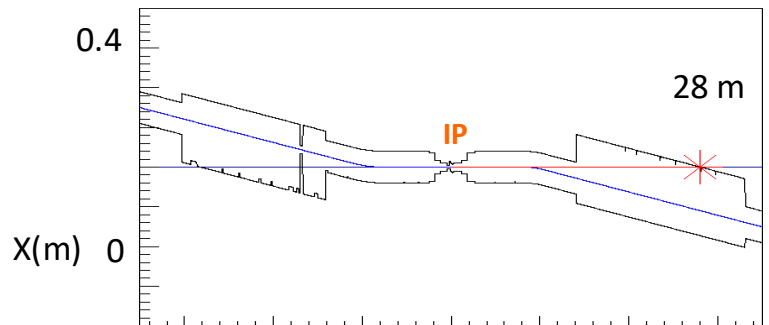
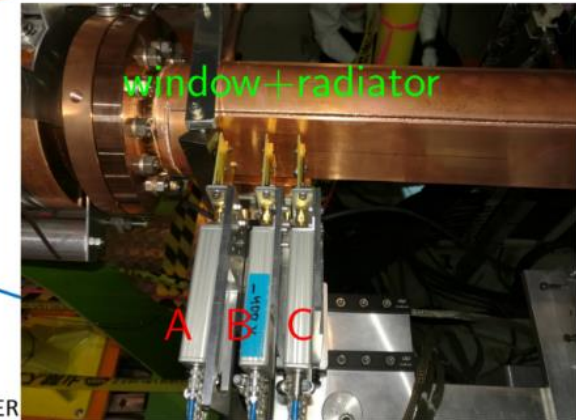
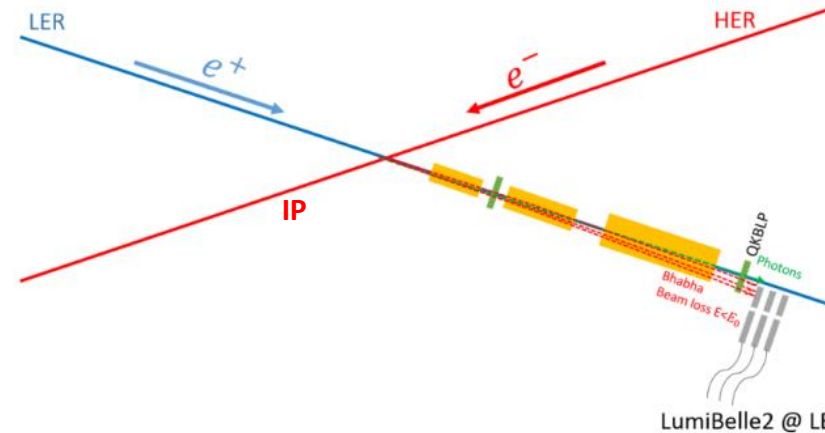

loss position distribution

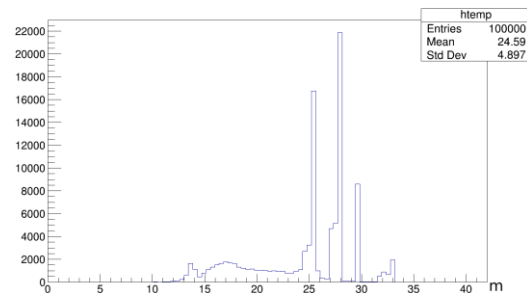

ELECTRON RING (measure γ)

- Photon ray-tracing in detailed vacuum chamber geometry + GEANT4
- Original position at 30 m (2018)
- New optimal position found at 28 m with \approx 10 times higher rate

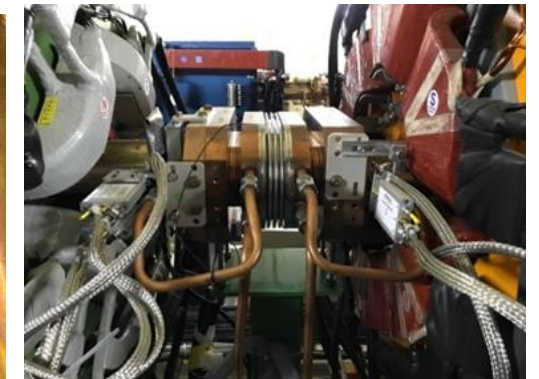
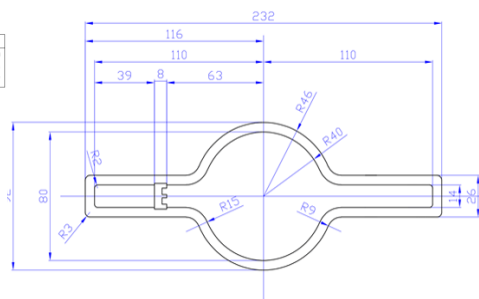

LumiBelle2 signal processing

Cheng Guo Pang et al., Nucl.Instrum.Meth. A931 (2019) 225-235

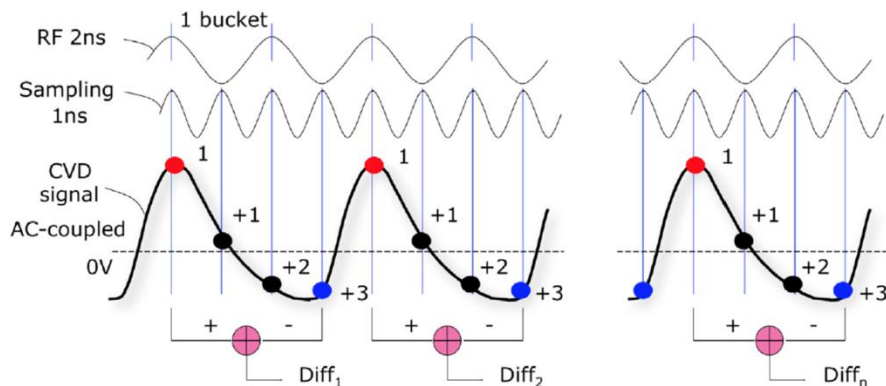

- 2 / 10 ns FWHM signals from 140 / 500 μm with 2 GHz current / low noise charge amplifier sampled every 1 ns
- Synchronized to RF clock \rightarrow continuous monitoring, averaging at 1 kHz and 1 Hz (bunch by bunch and all bunches together)
- Luminosity proportional to amplitude of signal peaks
 1. ADC is AC-coupled \rightarrow record difference between peak and baseline \rightarrow "TIL" & "BIL"
 2. Raw sum of all samples also \propto luminosity and recorded \rightarrow "RAWSUM"
 3. Number of peaks also recorded (constant fraction discriminator) \rightarrow "COUNT"

\rightarrow EPICS broadcasting @ 1 Hz

\rightarrow "1 Hz, 1 KHz, bunch-by-bunch, bunch-current" data streams transferred daily for archiving

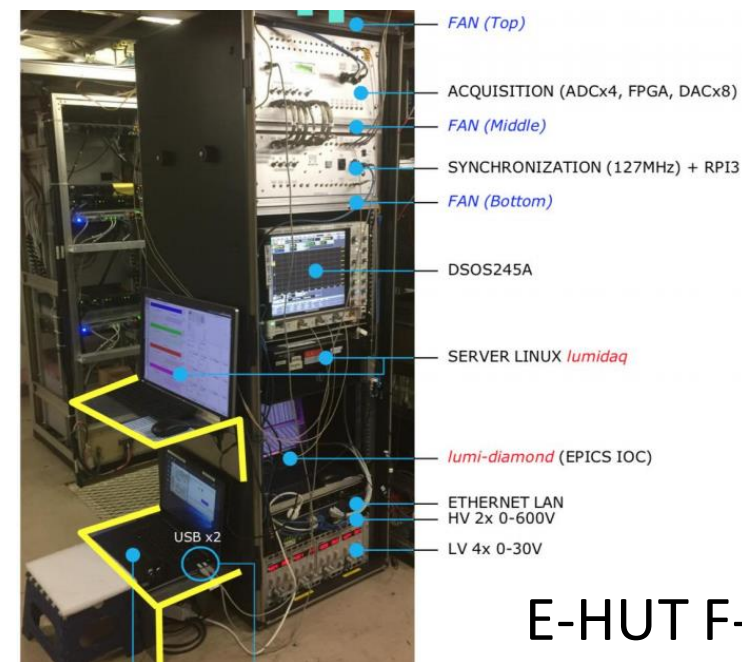

E-HUT F-8

Current status and further prospects

- LumiBelle2 operates successfully since 2018 providing useful input for SuperKEKB IP beam tuning (not presented here...)
- Continuous successful training of graduate students (master and PhD)
- Sustainability of long-term operation and overall maintenance in question
- Issue of radiation tolerance needs further study
- Starting collaboration with IHEP-Beijing group \rightarrow install customized low-cost radiation-hardened LGAD sensors (used by Atlas for LHC)
- A renewed upgraded LumiBelle2 needs to be prepared for operation beyond LS2 \rightarrow JENNIFER2 objective

Compton Polarimetry

➤ Goal

Extend physics reach of Belle II experiment by extending SuperKEKB capabilities beyond high luminosity
Optimize collision of polarized beams in the context of SuperKEKB electron beam polarization upgrade
→ rapid measurements of polarization are a key ingredient;

➤ Key elements (IJCLab contributions)

- **Laser systems:**
 - Accelerator integration including **synchronisation**;
 - Vacuum pipe design in high-lumi, high-current machine (SuperKEKB)
 - **Real time monitoring of the laser-beam polarization** to 0.1% accuracy (unavoidable systematic uncertainty on longitudinal polarization);
- **Photon detectors:**
 - Specific design for real-time monitoring
 - Demonstrator development.
- **Sensitivity studies**

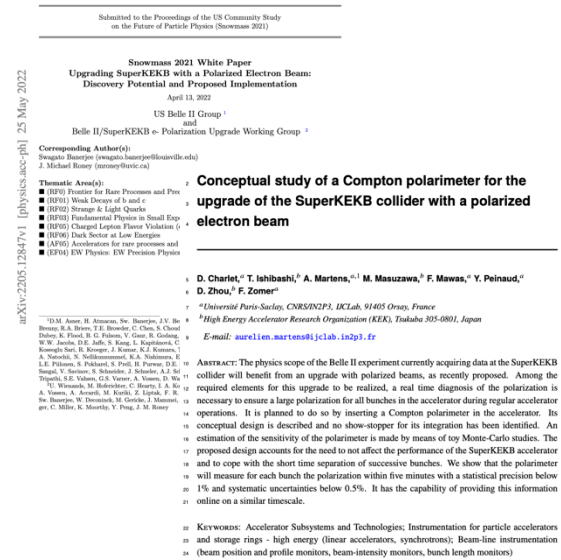

Recent highlights:

- Snowmass21 paper, <https://arxiv.org/abs/2205.12847>
- JINST 18 (2023) P10014

Laser system

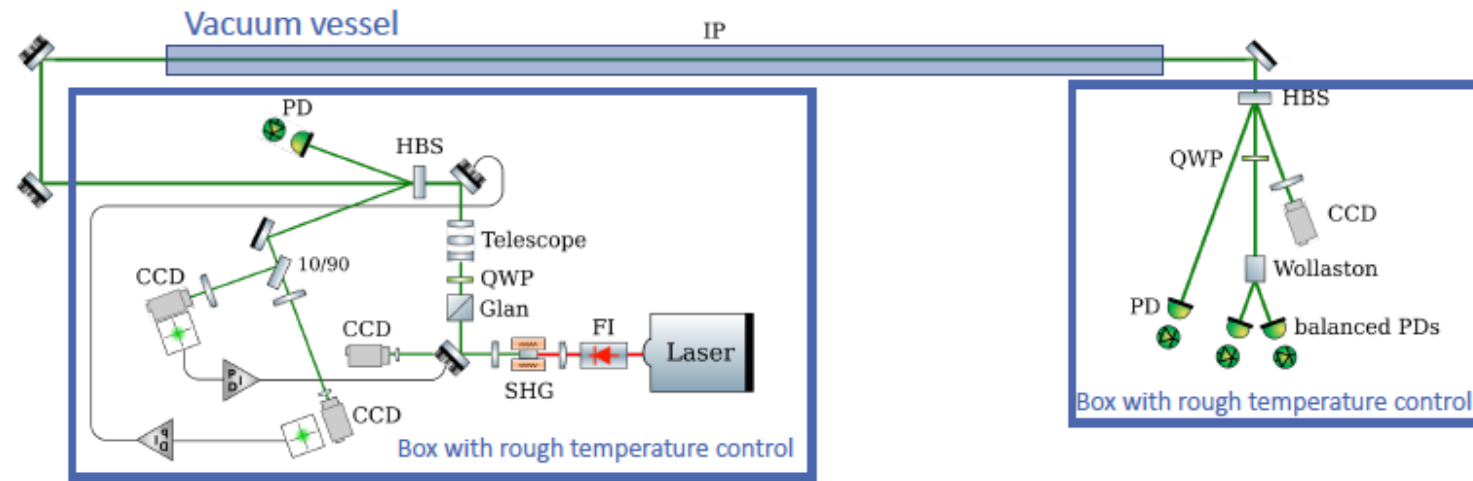

- Conceptual design is achieved
- Several integration aspects solved (location, needed modifications of beam pipe)
- **Current issues being addressed:**
 - Simple and low cost **synchronization concept for the laser in the accelerator**
 - WhiteRabbit technology (from CERN)
 - Implemented at IJCLab on IDROGEN board by high-synchronization and timing capabilities
 - First studies already launched with KEK experts, also including KEK ATF team
 - **Laser polarization control**
 - A critical systematics uncertainty component
 - Detailed optical modeling being pursued at IJCLab
 - Validation on optical test bench

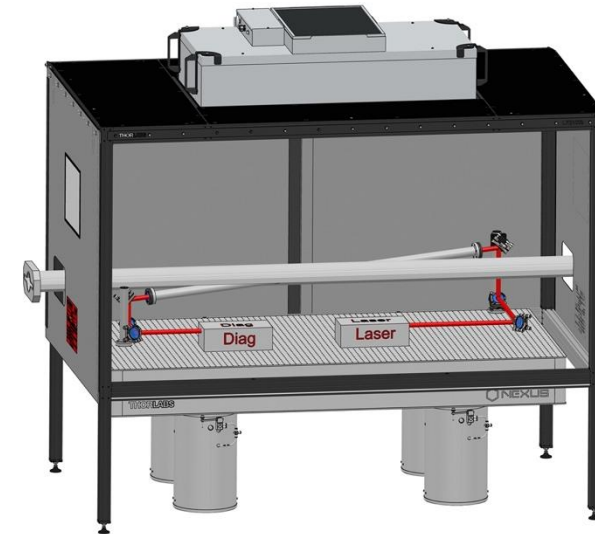

Conceptual implementation for SuperKEKB

NB: Synergetic with other HEP projects (FCC-ee, etc.)

Detector

- Conceptual design is achieved
- Several integration aspects solved (location, needed modifications of beam pipe)
- Idea is to measure energy of scattered photons since polarization of electron beam is expected to be longitudinal at the Compton integration point
- Preliminary Performance study very encouraging (<0.5% precision in 5min)

fit of MC for the simulated performance of SuperKEKB detector
→ next step: proto-detector

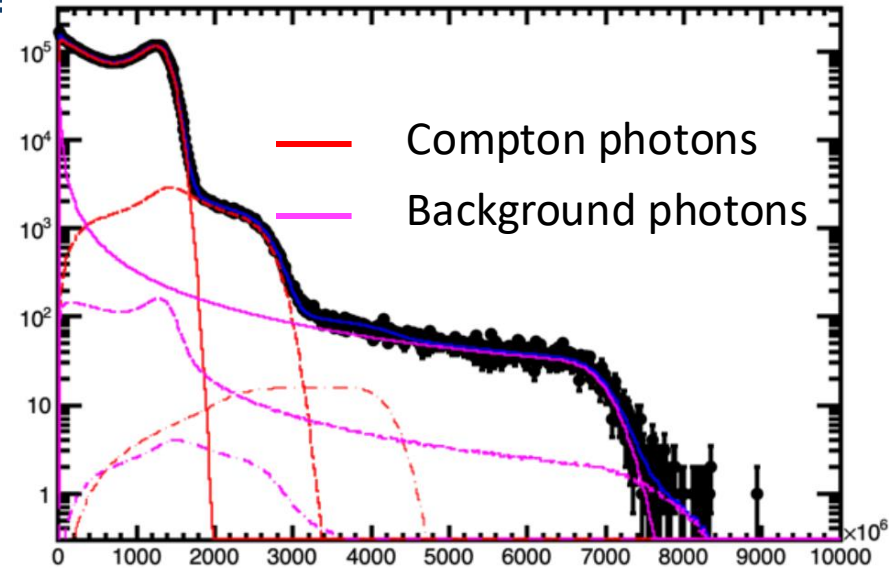

➤ Current issues being addressed:

- Bunch separation of 4ns at SuperKEKB implies development of a detector that fulfils the following requirements:
 - Fast: able to distinguish and measure deposited energy by photons 4 ns apart
 - Radiation tolerant: the signal induced radiation is large and must be sustained
 - Detector sampling must be synchronized to laser and RF for optimized performance
- Strategy is to develop a calorimeter based on BaF2, PMT with low transit time, tailored analog treatment before **ADC and FPGA based histogramming and analysis**
 - ADC+FPGA integrated on IDROGEN board and mezzanine; same as laser; to offer low cost, self consistent electronics for the Compton polarimeter as a whole
 - This electronic board is **also very useful for other accelerator diagnostics at KEK → joint performance demonstration**

NB: Funding request made to ANR for detector R&D (pending)

E_γ [eV]

FPGAs in Working Package 4 Task 3

- Starting point: novel FPGA-embedded sensors developed through INFN CSN5 (R&D) and CSN1 (Belle II) funding
- Activity in Jennifer 3: install sensors at Belle II interaction region and study possible enhancements
 - differentiate between response to thermal and non-thermal neutrons
 - position measurement of incident primaries (pixelated readout)
 - design simple-and-portable readout system based on commercial off-the-shelf electronics
 - use FPGA to read external analog sensors (e.g., readout of RadFETs or diamond detectors for total dose measurements)

FPGA-embedded SEU Monitors



- SRAMs used as hadron fluence sensors at LHC [1] and in proton therapy [2,3]
- Hadrons with energy > few MeV and thermal neutrons may indirectly induce SEUs in SRAMs

hadron fluence Φ = $\frac{N_{upsets}}{\sigma_{bit} N_{bits}}$ upset count

cross section per bit σ_{bit} memory size

- $\sigma_{bit} = \sigma_{bit}(\text{device}, V_{DD}, \text{hadron}, E)$
- Classic solutions: SRAM + readout device
- Our novel, patented solution [4,5]: sensor embedded in a SRAM-based FPGA
 - CRAM as sensitive element + fabric programmed as readout

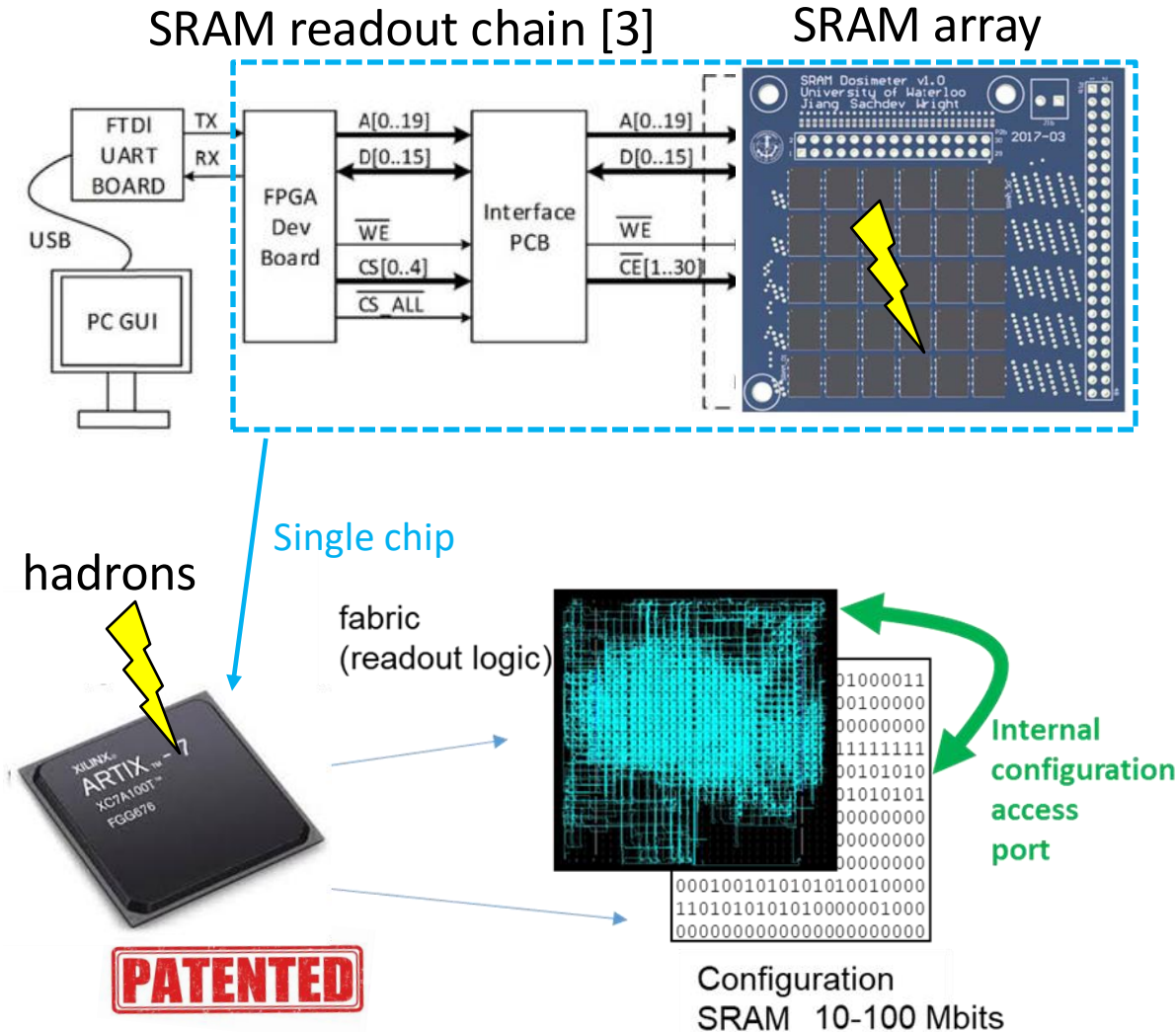

PATENTED

[1] doi: 10.1109/TNS.2014.2365042

[4] doi: 10.1109/TNS.2023.3265740

[2] doi: 10.1016/j.radmeas.2019.01.001

[5] tinyurl.com/yxcymnd7

[3] doi: 10.1109/TNS.2018.2884148

FPGA-embedded SEU Monitors at Belle II

Idea



- Arrange sensors in pairs, plain (thermal+fast) and shielded against thermal neutrons (fast only)
- Estimate thermal and fast neutrons fluence by difference
- Install 3 pairs: 1 at FWD (LER), 1 at BWD (HER), 1 on top of Belle II (PXD rack)

- SWX-238 polymer as thermal neutron shield
 - 27.6% boron in weight
 - 1-layer 1/8" thickness (3.2 mm)
 - Shields 99.75% thermal neutrons
 - Minimal thermalization of fast neutrons

shieldwerx™

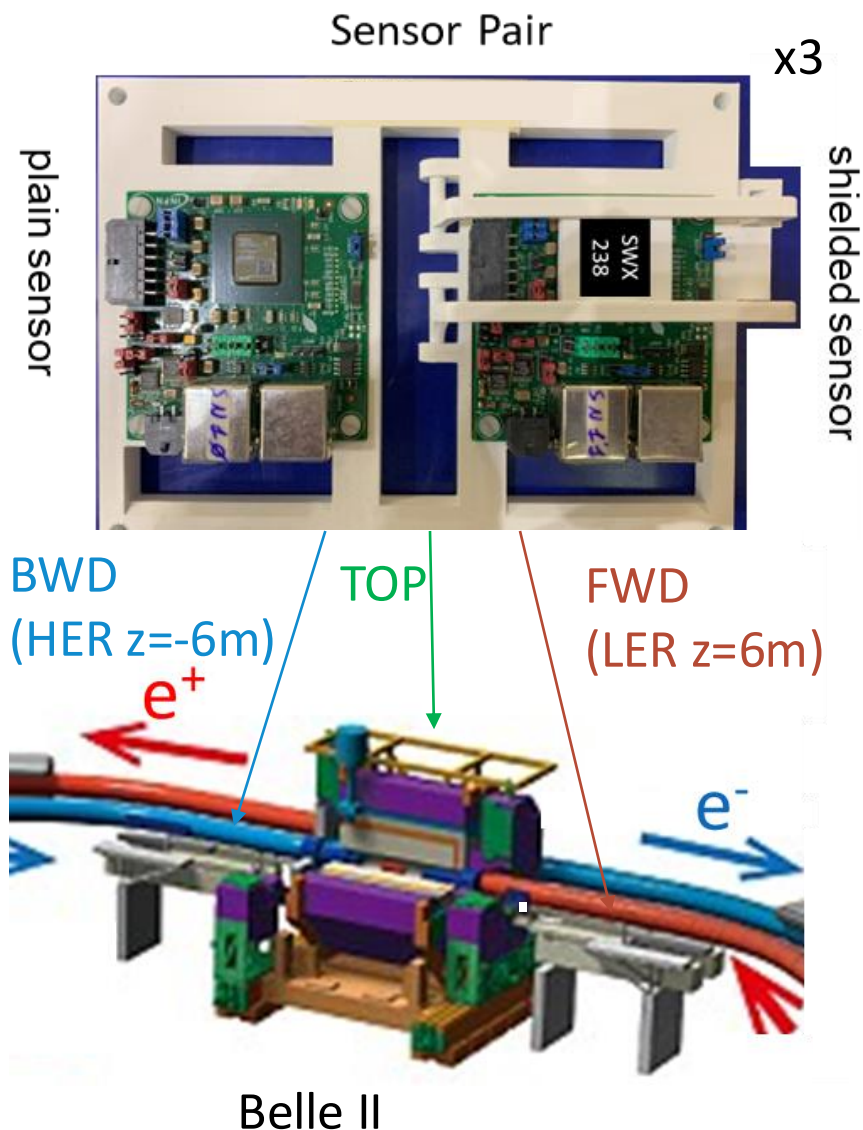

Readout System at Belle II



Use COTS Zynq-based SBC for sensor readout (Digilent Cora-z7)

- EPICS running on SBC
- InfluxDB (data collection) and Grafana (GUI) running on server at KEK
- Mirroring of data from KEK to INFN Naples
 - Redundancy, faster and easier access (public IP)

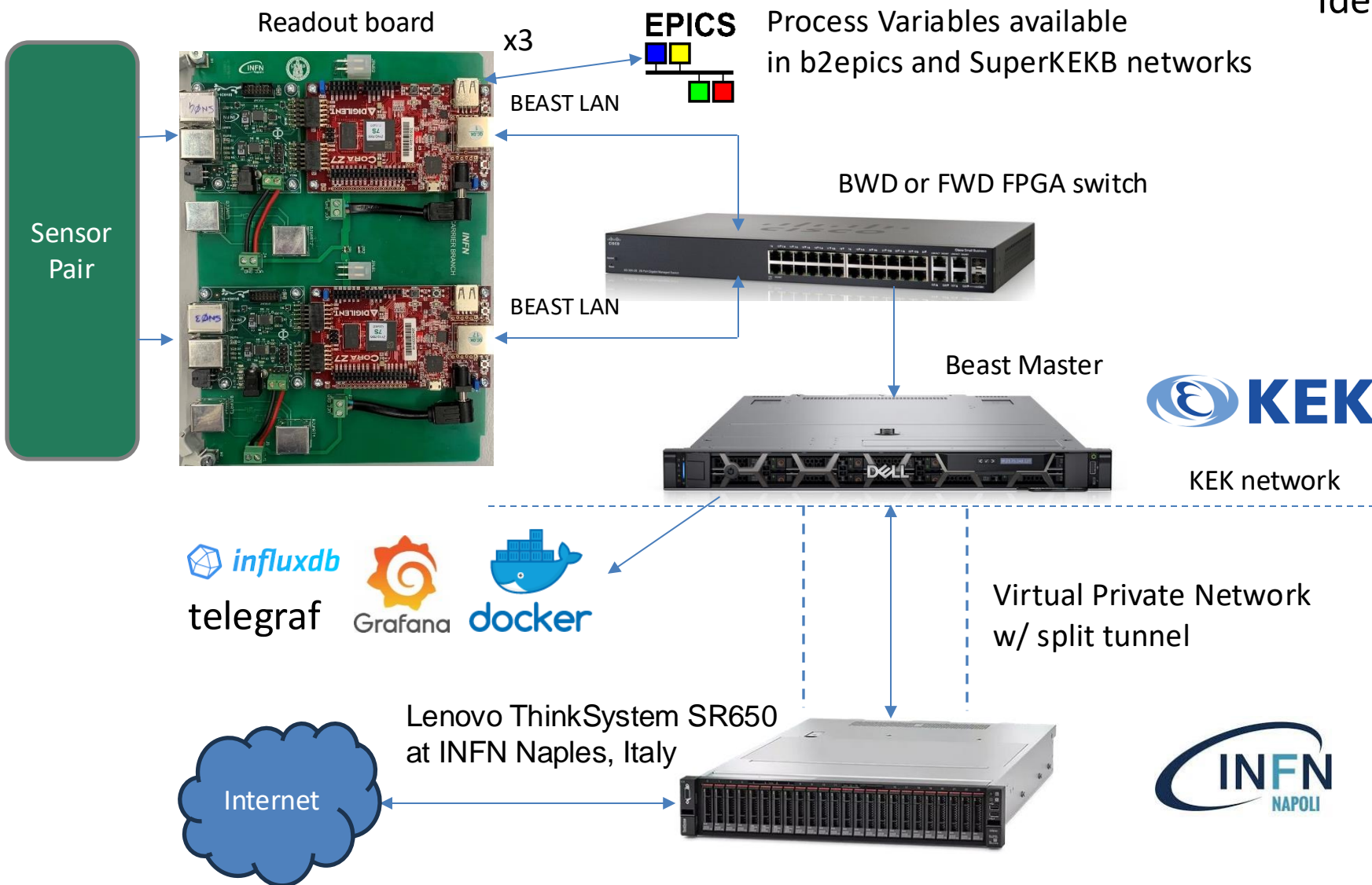

Conclusions

3 different subtopic in the task 4.3 of WP4 have been presented

- luminosity monitor @Belle II with diamond sensors
running since 2018 in Belle II
- Compton polarimeter construction to exploit polarization of the beam
conceptual design for laser and detector are advanced some technical points to be addressed
- FPGA based monitor system
in use and running in Belle II