

# Trigger and DAQ for CYGNO-04: *hardware-wise*

Herman Lima

[herman.lima@gssi.it](mailto:herman.lima@gssi.it)



- **LIME DAQ** (our current DAQ)
- **CYGNO-04 DAQ:**
  - ✓ **Plans: 1 year ago → Now**
  - ✓ **Hardware overview**
  - ✓ **Trigger modes**
  - ✓ **DAQ Synchronization**
  - ✓ **List of Material**
  - ✓ **Trigger Module v2**

# LIME DAQ

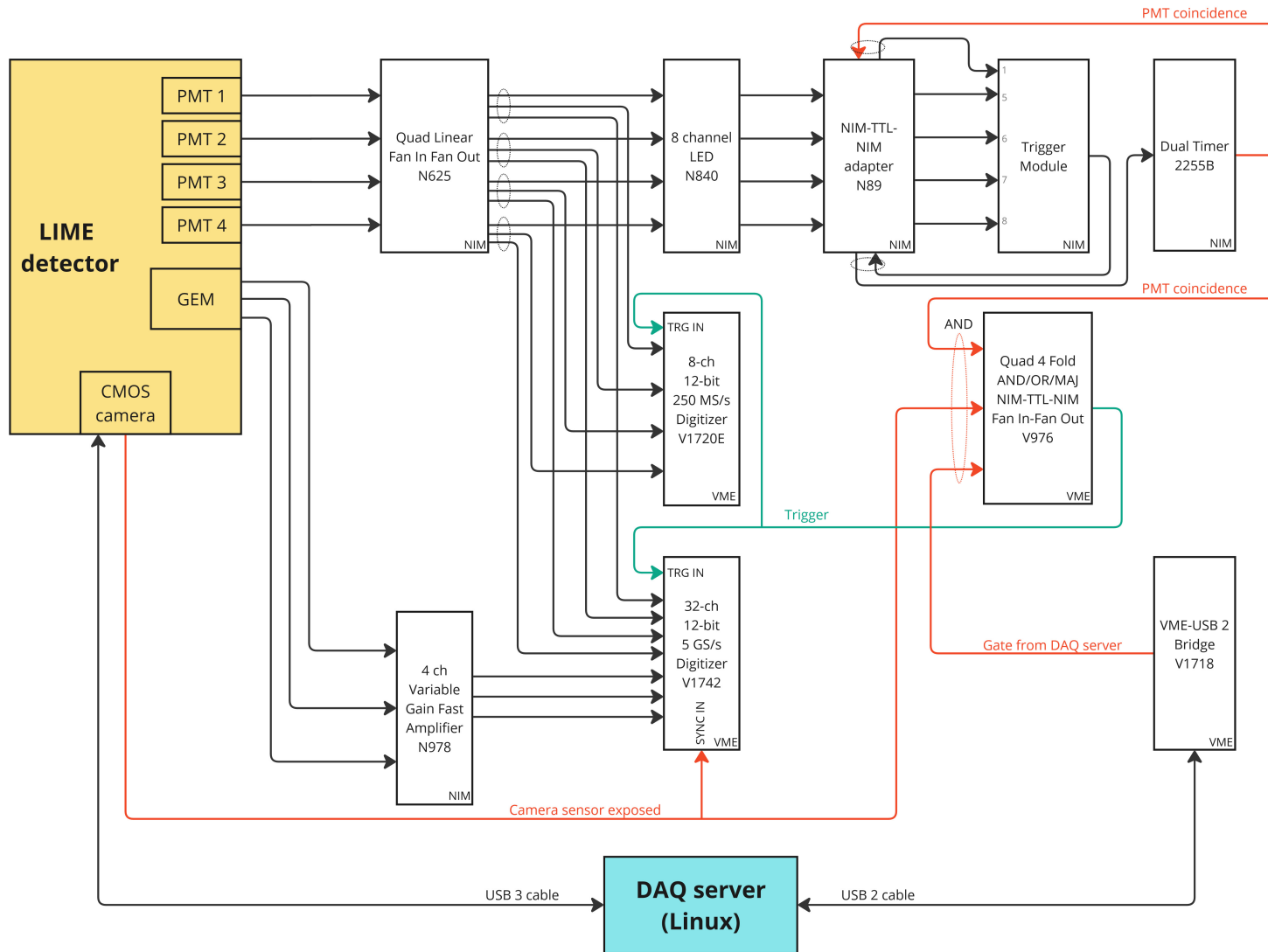

\* HV system not shown

Herman Lima - GSSI - 18/09/2024

# CYGNO-04 DAQ plans: 1 Year Ago

## Trigger and DAQ for CYGNO\_04

### Two readout path:

- **camera (4 Hamamatsu Orca-Quest):**
  - exposure 0.3 s/pic/cam @ 18 MB/pic/cam  
→ 60 MB/s/cam → 240 MB/s with 4 cameras → SSD local storage
  - CameraLink PCIe frame grabber @ 2.5 GB/s
- **photodetector (8 channels per side):**
  - Assuming a trigger rate of 10 Hz, a 12-bit digitization @ 750 MS/s,  $\lesssim 1 \mu\text{s}$ ,  $\sim 0.2 \text{ MB/s}$
  - Assuming a trigger rate of 10 Hz, a 12-bit digitization @ 250 MS/s,  $\lesssim 10 \mu\text{s}$ ,  $\sim 0.6 \text{ MB/s}$

### Two possible trigger levels:

- **HW trigger:** photodetector with minimal logic (e.g. majority)
- **Software trigger:** reconstruction of images and waveforms on a farm of CPUs/GPUs and based on interesting features (eg. clusters)

**MIDAS** used for Readout, Trigger and slow control

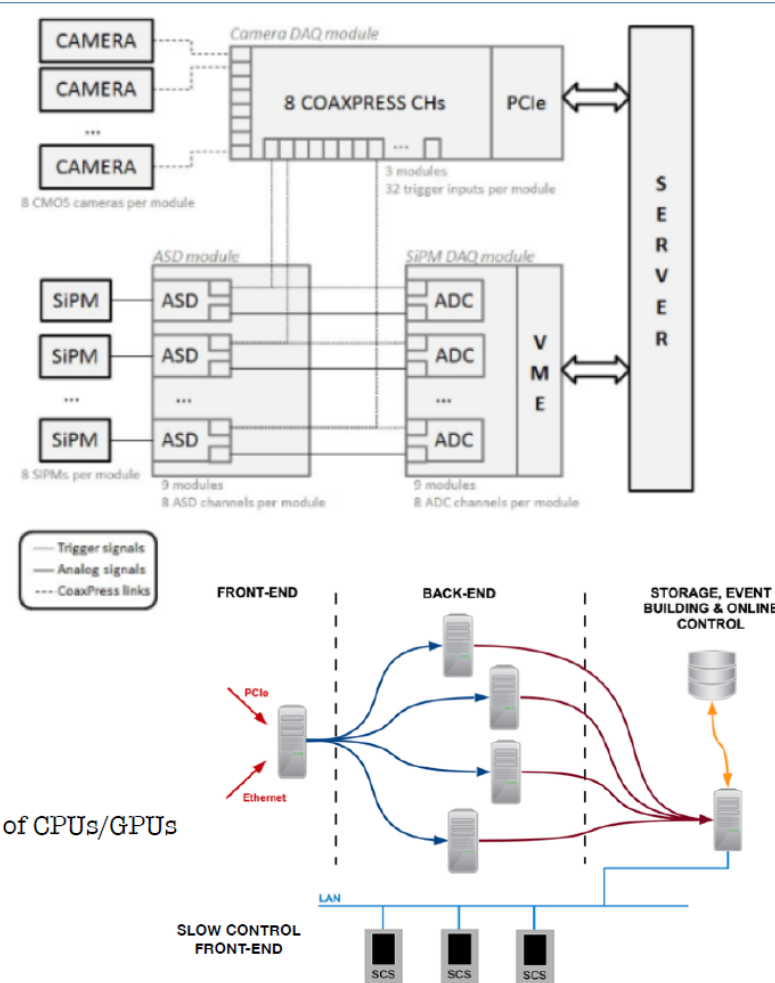

9

presented by S. Piacentini in the Collab. Meeting 2023, 06/12/2023

## Trigger and DAQ for CYGNO\_04

### Two readout path:

- **camera** (~~4 Hamamatsu Orca-Quest~~): **→ 6 Orca-Quest**
  - exposure 0.3 s/pic/cam @ 18 MB/pic/cam  
→ 60 MB/s/cam → ~~240 MB/s with 4 cameras~~ → SSD local storage **360 MB/s with 6 cameras**
  - ~~CameraLink PCIe frame grabber @ 2.5 GB/s~~ → **5 Gbps**
- **photodetector (8 channels per side):**
  - Assuming a trigger rate of 10 Hz, a 12-bit digitization @ 750 MS/s,  $\lesssim 1 \mu\text{s}$ ,  $\sim 0.2 \text{ MB/s}$
  - Assuming a trigger rate of 10 Hz, a 12-bit digitization @ 250 MS/s,  $\lesssim 10 \mu\text{s}$ ,  $\sim 0.6 \text{ MB/s}$

### Two possible trigger levels:

- **HW trigger:** photodetector with minimal logic (e.g. majority)
- **Software trigger:** reconstruction of images and waveforms on a farm of CPUs/GPUs and based on interesting features (eg. clusters)

**MIDAS** used for Readout, Trigger and slow control

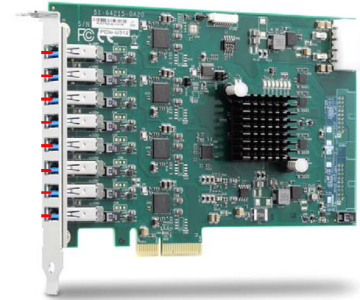
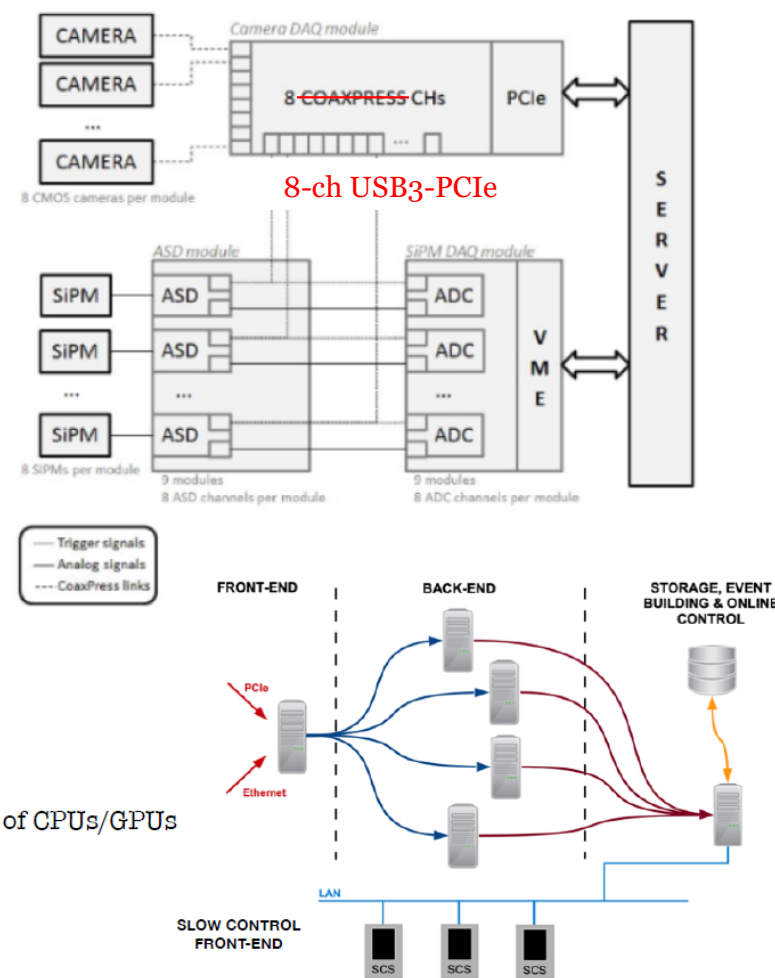

**PCIe-U308** (Adlink)  
- 8 ch frame grabber  
- delivery: mid-Dec  
- tests after Run 5

**a few updates**

presented by S. Piacentini in the Collab. Meeting 2023, 06/12/2023

# CYGNO-04 DAQ: Hardware overview

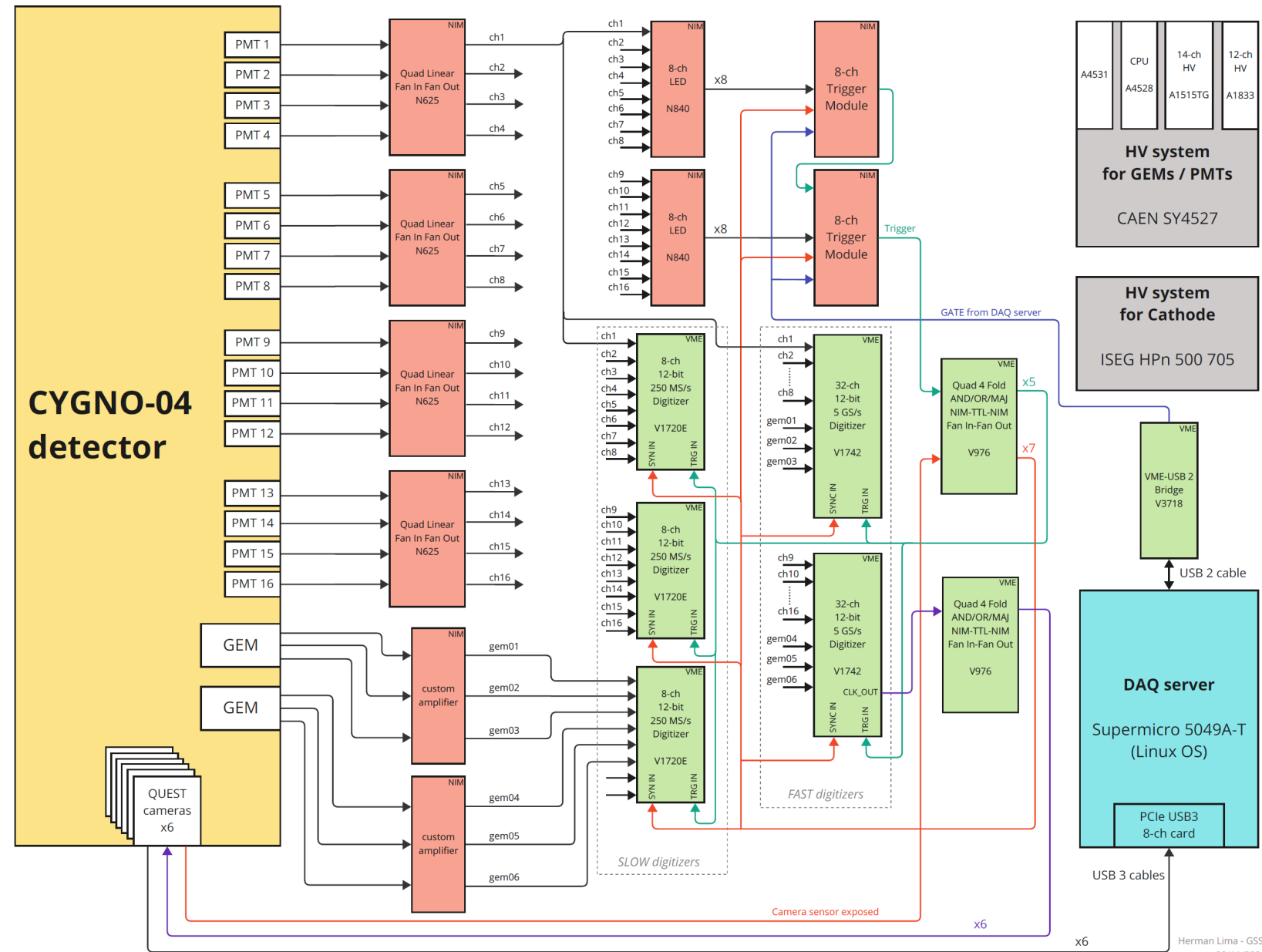

- Since CYGNO-04 is a dual TPC detector, the main idea is to design two independent data acquisition (DAQ) paths (discr-trigger-digitizers) that can also run in a 'combined mode'.
- This solution allows to acquire events from a single TPC (8 PMTs, 3 cameras) or the whole detector.
- A possibility under discussion is to read (digitize) the output of the third-layer GEM.

# CYGNO-04 DAQ: Trigger modes

- A DAQ architecture that can read each TPC alone (*single mode*), or both TPCs (*combined mode*), allows the possibility to run CYGNO-04 in different **Trigger modes** (scenarios):
  - **PHYSICS**: DM search mode, no need to run in 'combined mode'
  - **COSMICS**: could be useful to run in 'combined mode'
  - **PEDESTAL**: run each TPC independently ('single mode')
  - **CALIBRATION**: iterations between 'single' and 'combined' modes



**TO BE DISCUSSED**

# CYGNO-04 DAQ: Synchronization

- The major feature not optimized in LIME data acquisition is the long **deadtime** between two consecutive images. The camera is triggered by software through the DAQ server.
- Proposed solution: change the camera operation mode from 'software trigger' to **External Trigger mode (Trigger times)**.
- One of the digitizers is the Master, sending a reference *ext\_trigger* to the six cameras.
- The exposure time of the cameras is defined as the number of *ext\_trigger* periods (1 to 10k).
- Both the exposure and readout of the camera are made by the external trigger, reducing the deadtime.

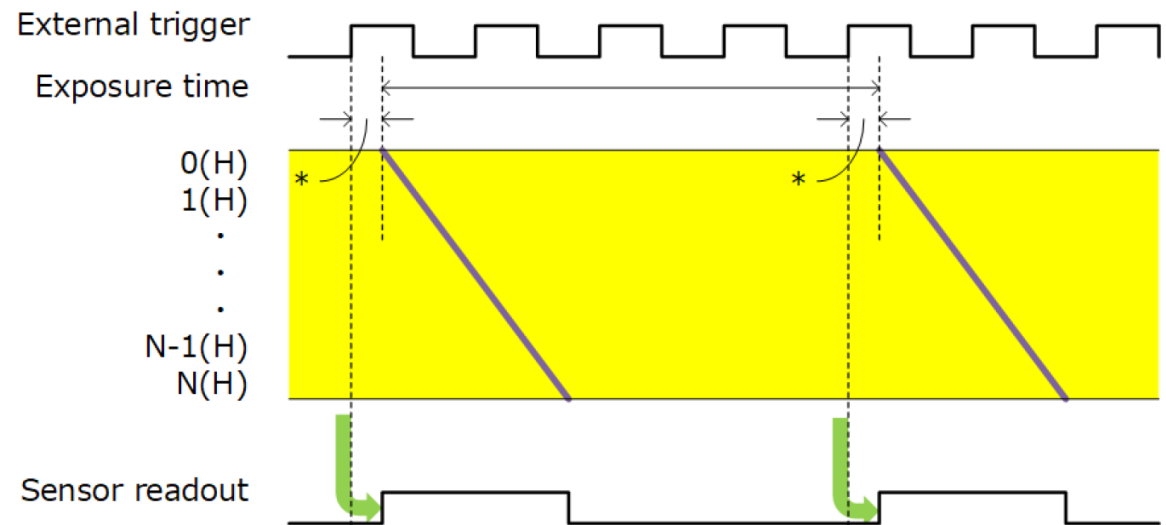

From page 45 of 'C15550-20UP/C15550-20UP01 Instruction Manual'.



# CYGNO-04 DAQ: Synchronization

- The acquisition of the camera is realized by opening a Gate with the DAQ server.
- A *Trigger Time Tag* (TTA), in each digitizer, is reset at the start of the exposure (beginning of a Run). TTA is provided by a 60 bits (V1742, Fast Digitizer), and 48 bits (V1720, Slow Digitizer), scaler embedded in the read data packet.
- Each Trigger-Module provides for one of the digitizers an 8-bits mask (*trigger\_mask*) with the PMTs fired for the corresponding Trigger pulse.  
The *trigger\_mask* is embedded in the data packet, so that it's possible to recover from the data which detector caused the trigger.
- With all these information, the Event Builder will be able to fully reconstruct the events for both detectors.

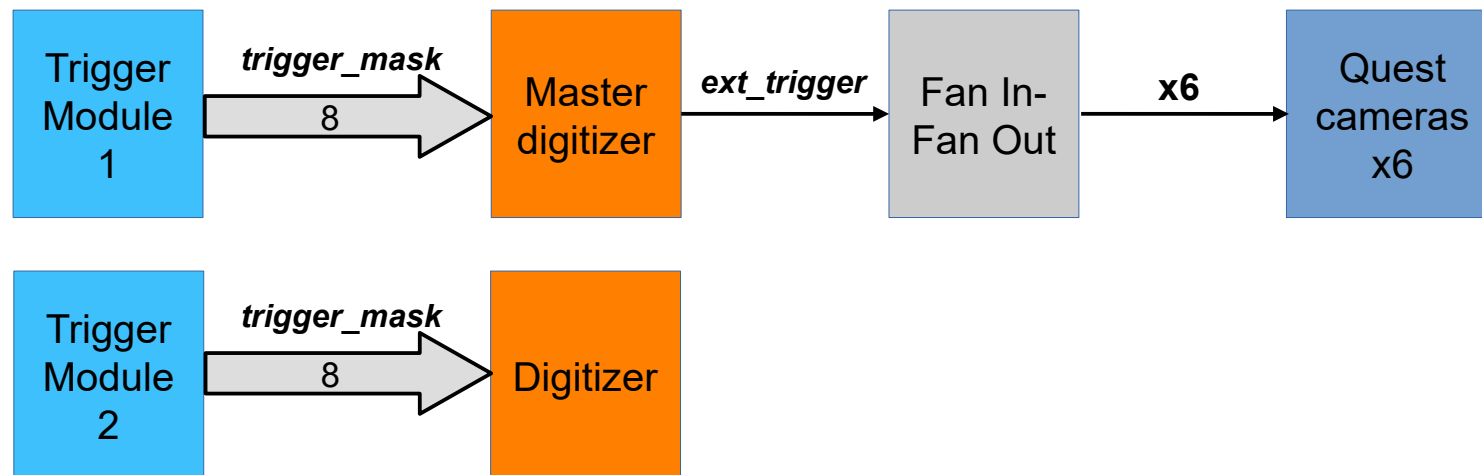

# CYGNO-04 DAQ: List of Material

	GROUP	DESCRIPTION	Model	Manufact.	Need	Available	TO	Notes
							ORDER	
1	NIM module	Quad Linear Fan In Fan Out	N625	CAEN	4	4	0	1 available at LNF and 2 ordered
2	NIM module	8-ch Discriminator	N840	CAEN	2	2	0	1 available at LNF
3	<del>NIM module</del>	<del>4-ch Fast Amplifier</del>	<del>N978</del>	<del>CAEN</del>	<del>2</del>	4	4	D. Pinci said there is a custom amplifier design going on and this module won't be used in CYGNO04 (21/10/24).
4	NIM module	8-ch Trigger Module	TM v2	GSSI	2	1	1	under development / estimated delivery of new comps. mid Dec
5	NIM crate	12-slots standard NIM crate		CAEN	1	3	-2	1 available at LNF and 1 at LNGS
6	VME module	8-ch, 250MSPS Digitizer	V1720E	CAEN	3	3	0	2 available, need 1 more because of the GEMs (28/10/24)
7	VME module	32-ch, 5GSPS Digitizer	V1742	CAEN	1	3	-2	1 available at LNF and 1 at LNGS
8	VME module	Quad 4 fold Logic, NIM-TTL-NIM	V976	CAEN	2	1	1	1 fanout of the Trigger signal and 1 Clock to cameras
9	VME module	VME-USB2 Bridge	V3718	CAEN	1	1	0	1 available at LNF (accord. to Francesco Renga)
10	VME crate	4U, 8 slots, VME64 std crate	VME8008B	CAEN	1	1	0	8 slots used / I said to D. Pinci that it is safer to replace by a 21-slot standard crate (21/10/24). Ex: CAEN VME8100
11	HV module	12-ch for the PMTs	A1833	CAEN	1	1	0	
12	HV module	14-ch HV for Triple-GEMs	A1515BTG	CAEN	1	1	0	
13	HV crate	Universal Multichannel Power Supply System	SY4527	CAEN	1	1	0	
14	HV system	AC/DC High-Voltage Power Supply	HPn 500 705	ISEG	1	1	0	
15	Computing	8-ch, USB3-PCIe interface card	PCIe-U308	ADLINK	1	0	1	1 unit ordered by GSSI / estimated delivery mid December
16	Computing	Graphics Processing Unit (GPU)	???	???	1	1	0	according to D. Pinci (21/10/24) one (maybe 2) GPU is already installed in LIME DAQ Server.
17	Computing	USB 2 cable (Type-A to Type-C connectors)			1	0	1	check if available at LNF
18	Computing	USB 3 long cable			6	0	6	
19	Computing	Xeon processor workstation (DAQ server - Linux)	5049A-T	Supermicro	1	1	0	
20	Computing	Computer (Windows OS)			1	1	0	
21	Sensor	Orca Quest qCMOS camera	C15550-20UP	Hamamatsu	6	1	5	5 new cameras ordered by GSSI (nov/24)
22	Sensor	Photomultiplier Tube (PMT)	R7378	Hamamatsu	16	4	12	ordered?
	* Minimum Requirements.							

# CYGNO-04 DAQ: Trigger Module v2

## REMEMBERING:

- The **Trigger Module** is a custom module (NIM format) designed for LIME/CYGNO, based on two small cards: an FPGA board and a Raspberry Pi.
- Perform three logic functions (remotely selectable): AND, OR, Majority
- Accessible through Ethernet connection (SSH) for remote configuration of seven internal registers.
- The FPGA firmware can also be remotely updated, using a local computer connected via USB.

## IMPROVEMENTS in version 2:

- 16 IO's → **22 IO's**
- Only TTL/LVTTL inputs → **8 NIM inputs** (using a new custom conversion board)
- NIM rear connector included for power supply
- New processing capabilities are planned for the inputs 'Camera Exposed', Gate, Trigger In, GEM.

# CYGNO-04 DAQ: Trigger Module v2

## 22 IOs in Trigger Module v2

### INPUTS (15):

- 8 PMT input channels ('PMT ch X')
- 3 for the 'sensor exposed' output of the cameras
- 1 for a GEM logic ('trigger') signal
- 1 for the GATE signal from the DAQ server
- 1 for an external trigger signal
- 1 for an external clock signal

### OUTPUTS (3):

- 1 clock
- 1 trigger output (to be distributed by a V976 module)
- 1 monitoring output (for debugging)
- 4 Not Connected (now)

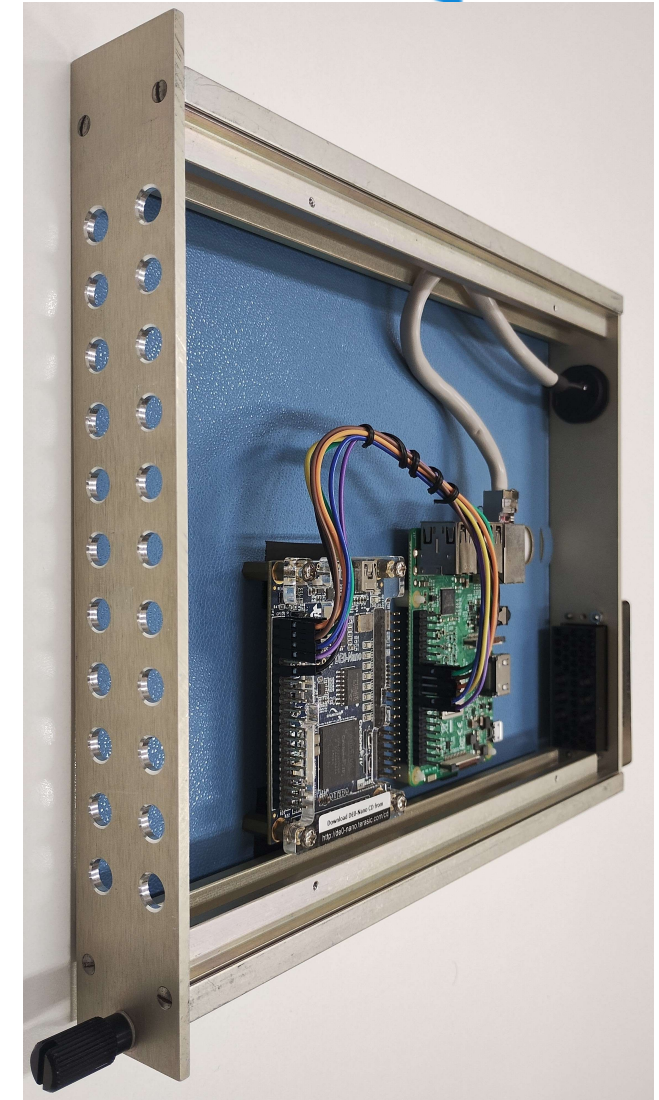
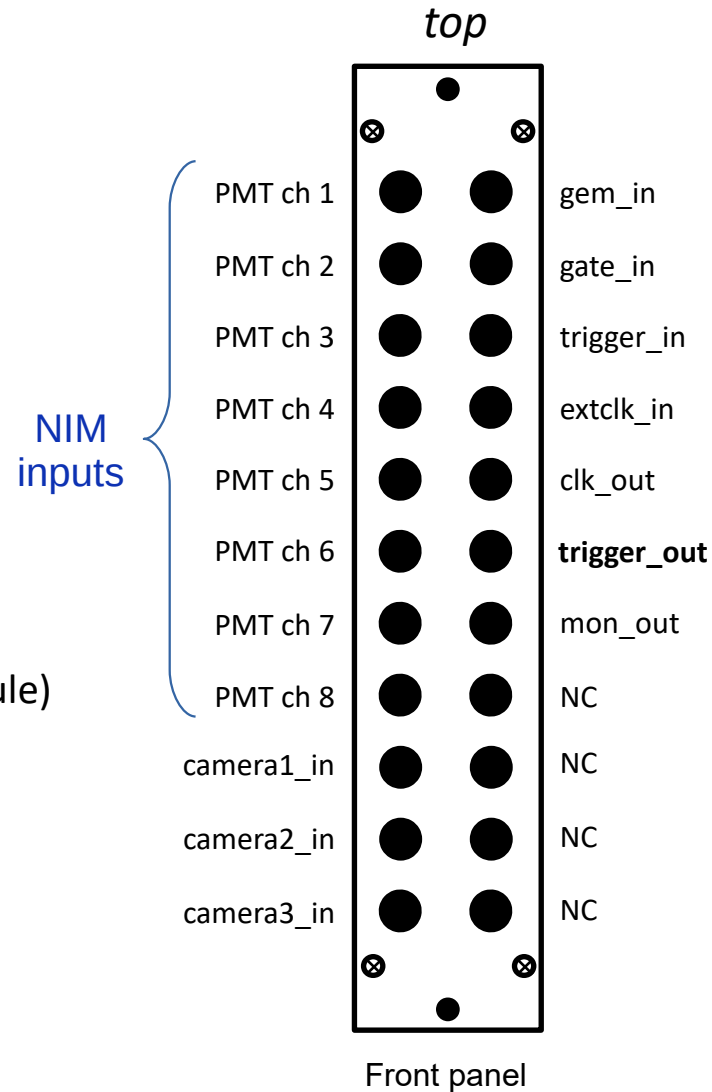

Trigger Module v2 under development.

Thank you for  
your attention.