

# DeSyT-2025

Catania (Italy), February 24 -26, 2025

INTERNATIONAL WORKSHOP ON  
DETECTION SYSTEMS AND TECHNIQUES  
FOR FUNDAMENTAL AND APPLIED PHYSICS



Istituto Nazionale di Fisica Nucleare

## *The Cross-talk problem for a neutron correlator: preliminary results on the CROSSTEST@LNL experiment for NArCoS*

**E. V. Pagano<sup>1</sup>, A. Barbon<sup>3,4</sup>, C. Boiano<sup>2</sup>, G. Cardella<sup>3</sup>, A. Castoldi<sup>2,5</sup>, E. De Filippo<sup>3</sup>, E. Geraci<sup>3,4</sup>, B. Gnoffo<sup>3,4</sup>, C. Guazzoni<sup>2,5</sup>, G. Lanzalone<sup>1,6</sup>, C. Maiolino<sup>1</sup>, T. Marchi<sup>7</sup>, N.S. Martorana<sup>3</sup>, F. Noto<sup>1</sup>, A. Pagano<sup>3</sup>, S. Pirrone<sup>3</sup>, G. Politi<sup>3,4</sup>, L. Quattrocchi<sup>3,8</sup>, F. Risitano<sup>3,8</sup>, F. Rizzo<sup>1,4</sup>, P. Russotto<sup>1</sup>, G. Saccà<sup>3</sup>, G. Santagati<sup>3</sup>, M. Trimarchi<sup>3,8</sup>, and C. Zagami<sup>1,4</sup>**

<sup>1</sup>INFN, Laboratori Nazionali del Sud, Catania, Italy

<sup>2</sup>INFN, Sezione di Milano, Milano, Italy.

<sup>3</sup>INFN, Sezione di Catania, Catania, Italy.

<sup>4</sup>Dipartimento di Fisica ed Astronomia, Università di Catania, Catania, Italy.

<sup>5</sup>Politecnico di Milano, Dip. Elettronica, Informazione e Bioingegneria, Milano, Italy

<sup>6</sup>Università di Enna "Kore", Enna, Italy.

<sup>7</sup>Dipartimento di Scienze MIFT, Università di Messina, Messina, Italy.

<sup>8</sup>Dipartimento di Scienze MIFT, Università di Messina, Messina, Italy.

**CHIRONE Coll.**



# IDEA

**To realize a prototype of detector able to detect at the same time charged particles and neutrons with high energy and angular resolution for reaction studies and applications**

- Candidate: The plastic scintillator EJ276-Green Type (ex EJ299-33) ( $3 \times 3 \times 3 \text{ cm}^3$ )
  - 1 cluster: 4 consecutively cubes  $\rightarrow 3 \times 3 \times 12 \text{ cm}^3$
  - Reading the light signal: SiPM and digitalization
  - Neutron detection efficiency  $\approx 50\%$  for the prototype (16 clusters)
  - Modular, reconfigurable (in mechanic and electronic)
  - Discrimination of  $n/\gamma$  from PSD (but also light charged particles)
  - Energy measurement from ToF ( $\Delta t \leq 0.5 \text{ ns}$  with  $L_{\text{ToF}} \approx 1 \div 1.5 \text{ m}$ )
- TOF measured using the RF of the CS or with an ancillary MCP (low intensity exotic beams)

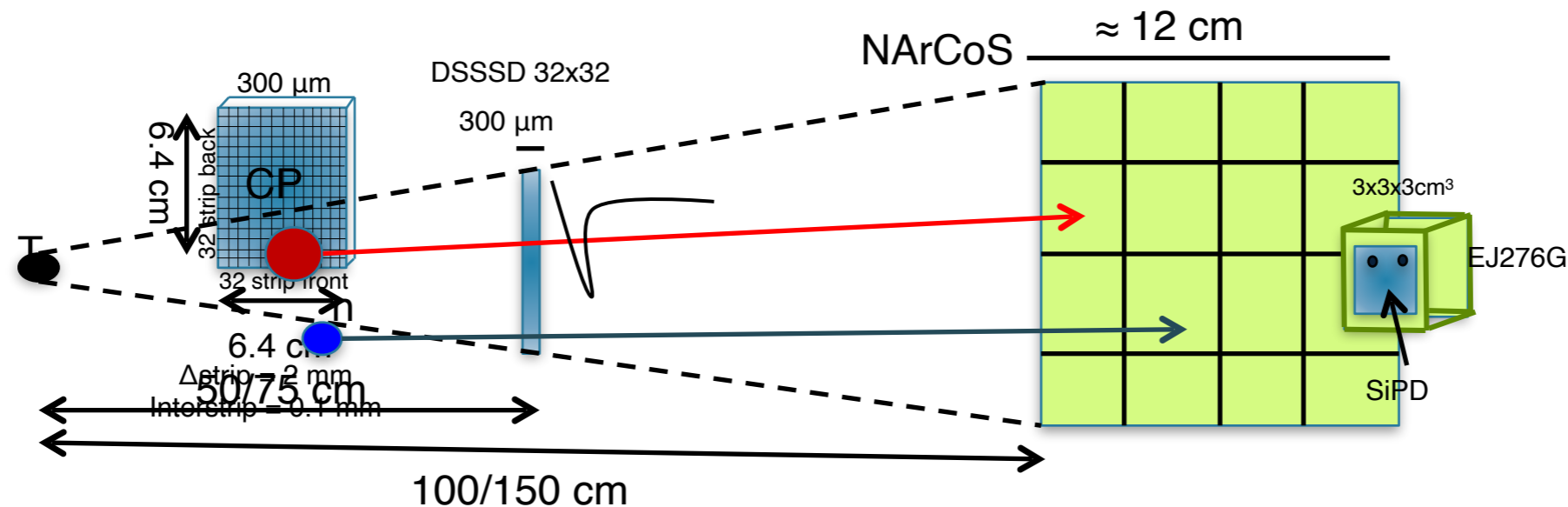

# Expected performances

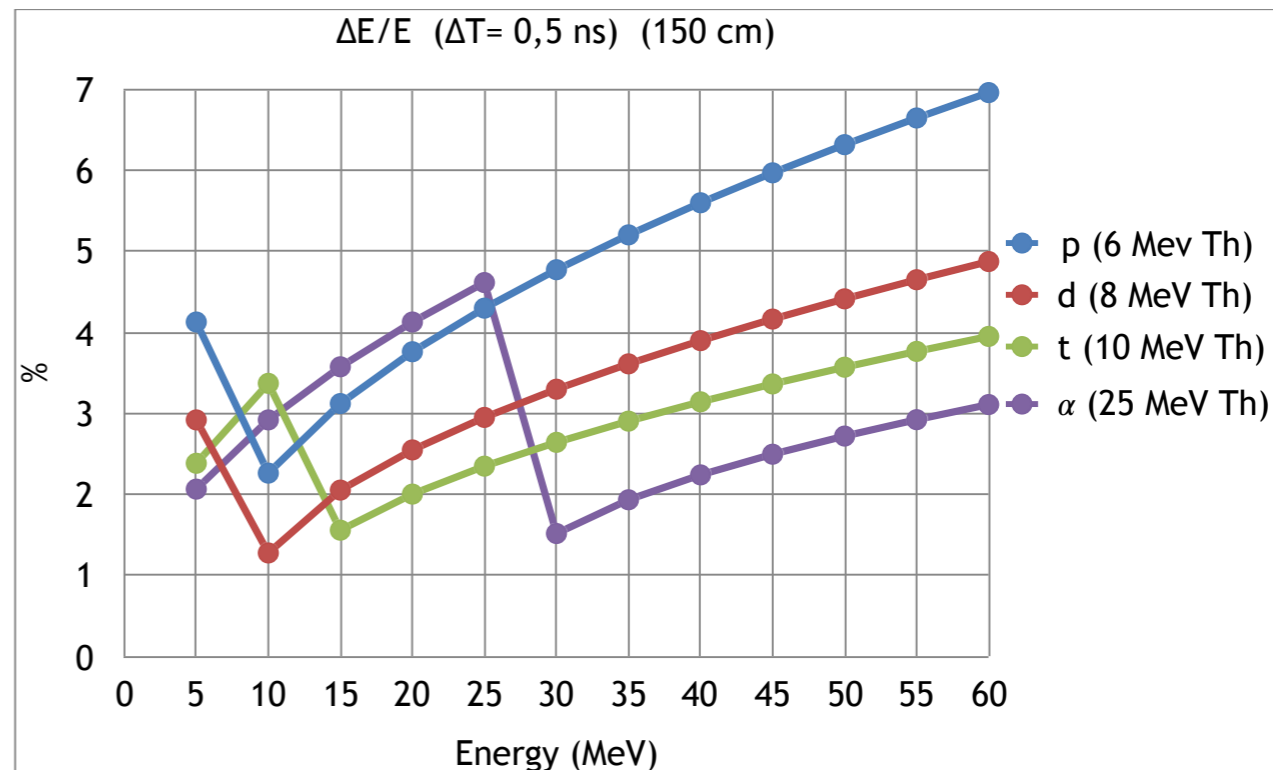
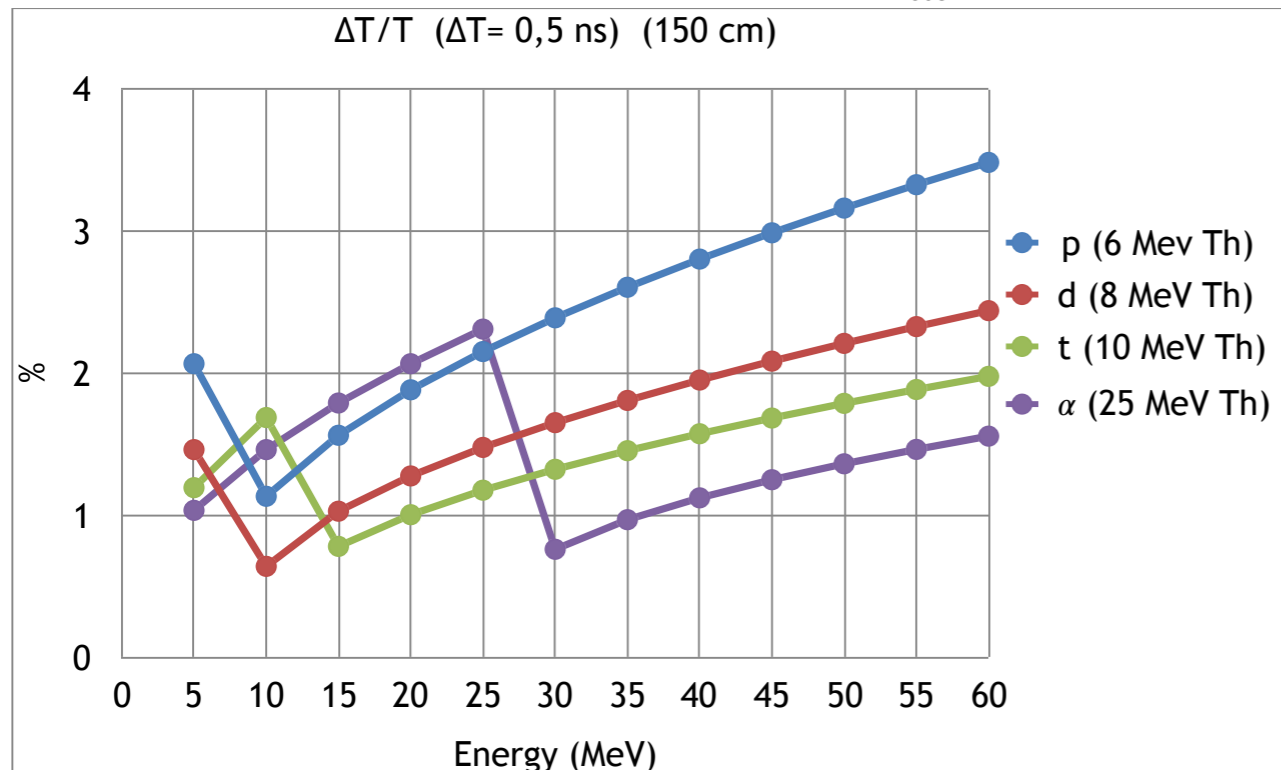
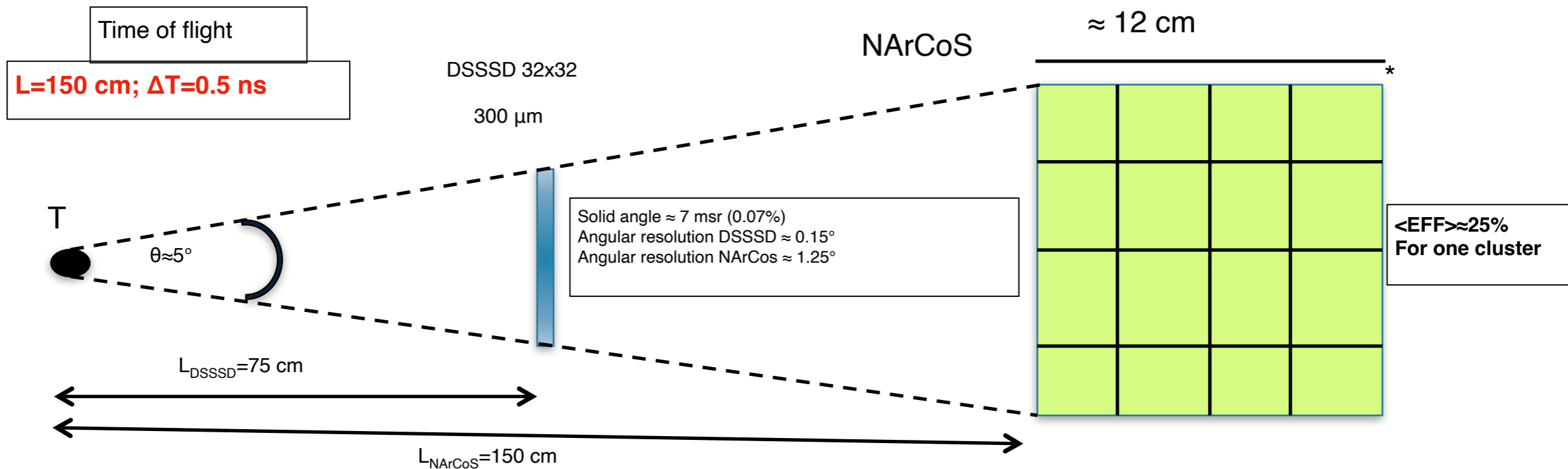

\*the mechanical structure will have the possibility of an angular movimentation

# Expected performances

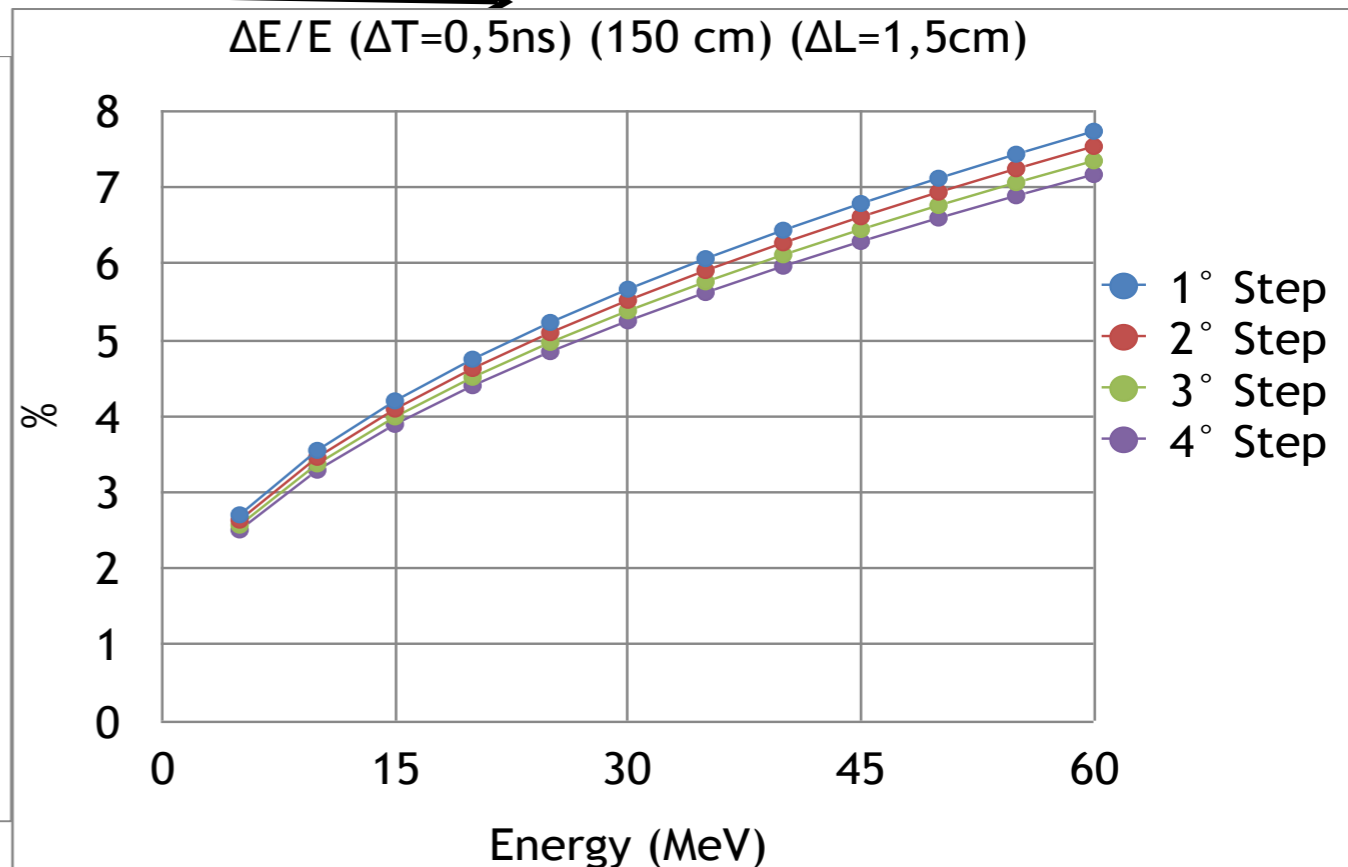
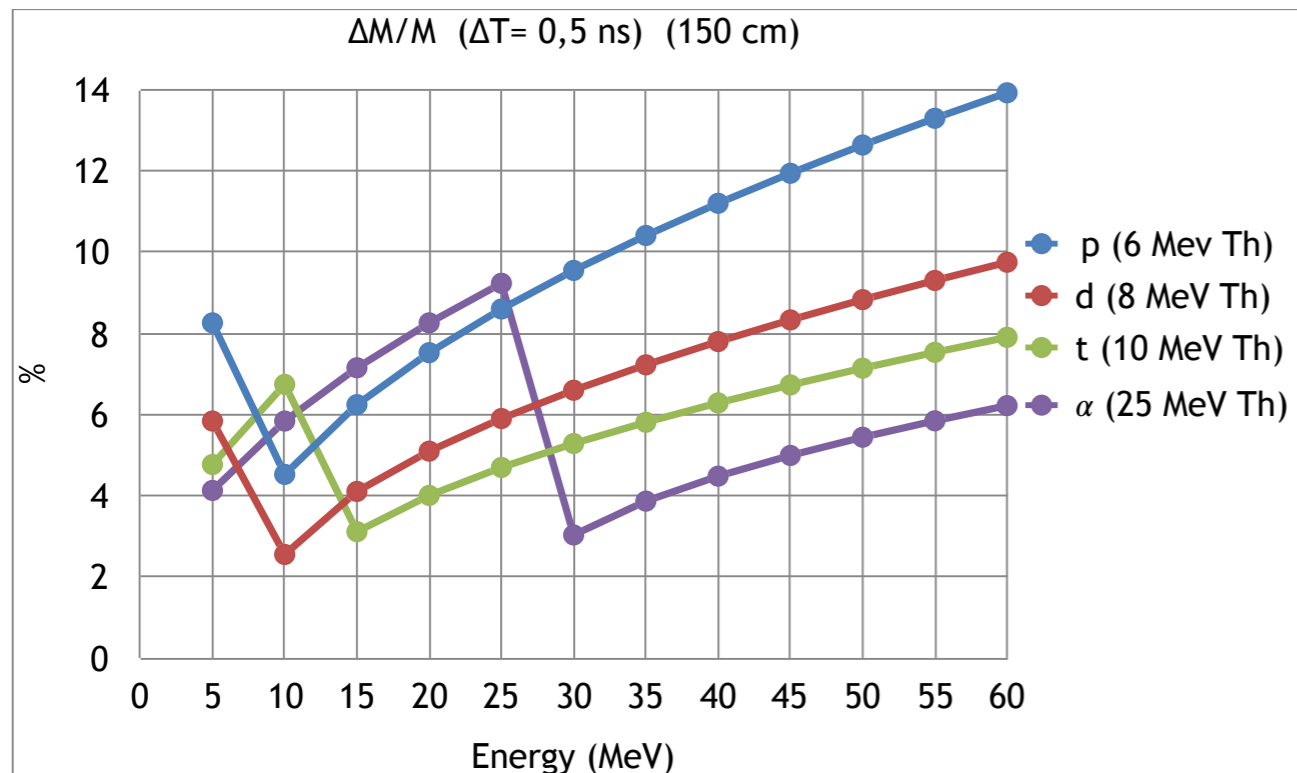
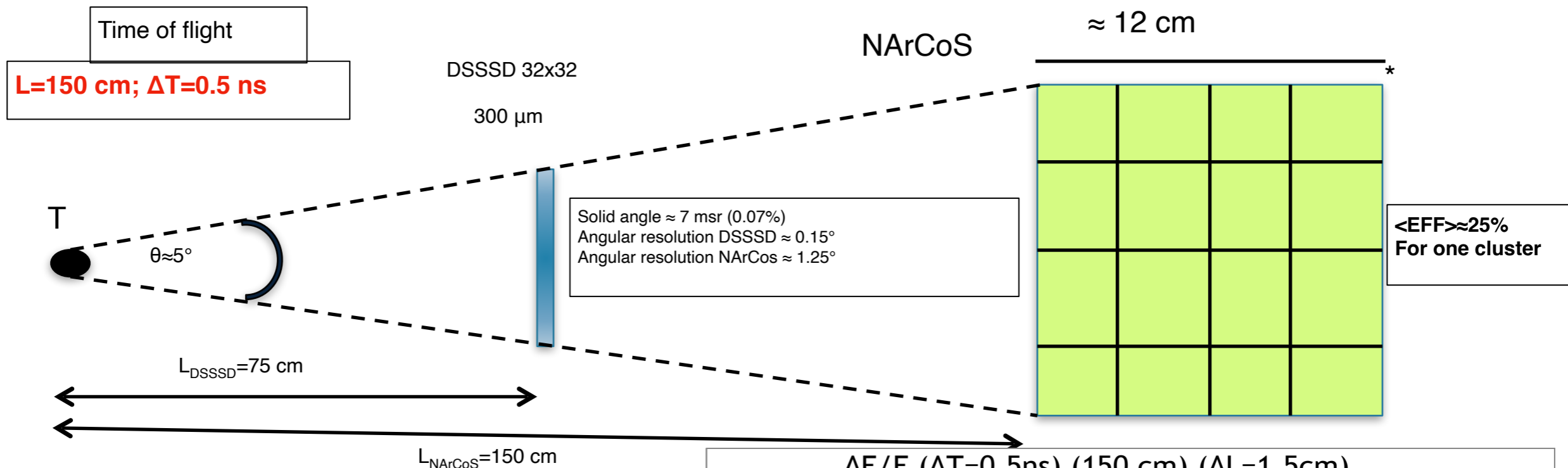

\*the mechanical structure will have the possibility of an angular movimentation

# Preliminary results of CROSSTEST exp. @LNL (end of 2023)

One of the main problem is to manage the cross-talk among the elementary cells

Spokesperson(s): E.V. Pagano, G. Politi, P. Russotto, T. Marchi

The 3x3 Matrix (surface crosstalk)

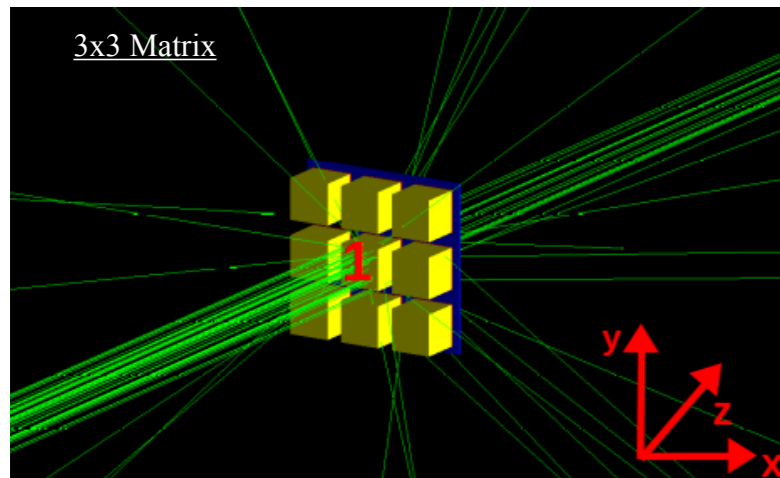

Two configurations was tested

Main reaction for neutrons

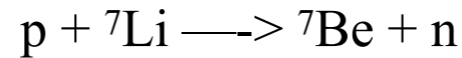

The 3 clusters (linear crosstalk)

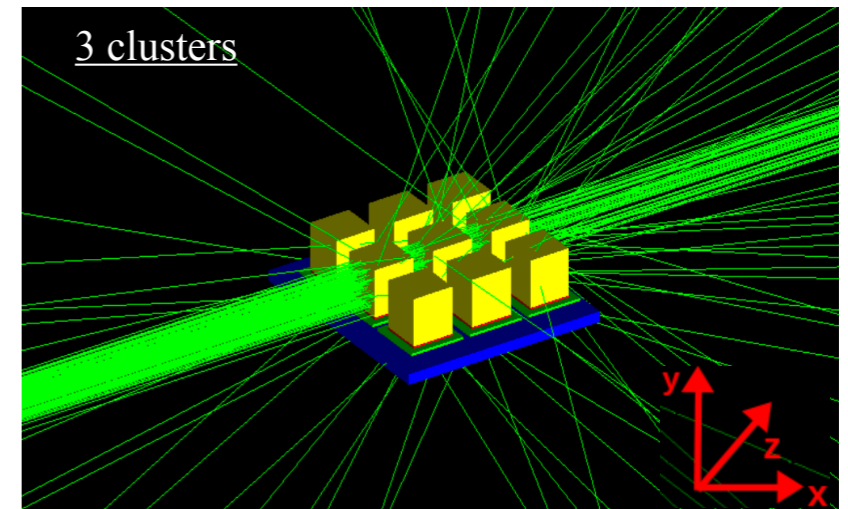

The experiment was performed at CN accelerator of INFN-LNL laboratory using a proton beam of 4.5 MeV on a LiF target producing a neutron beam having energy  $E_n < 4.5$  MeV (neutron experimental threshold 1.5 MeV)

## Experimental Setup

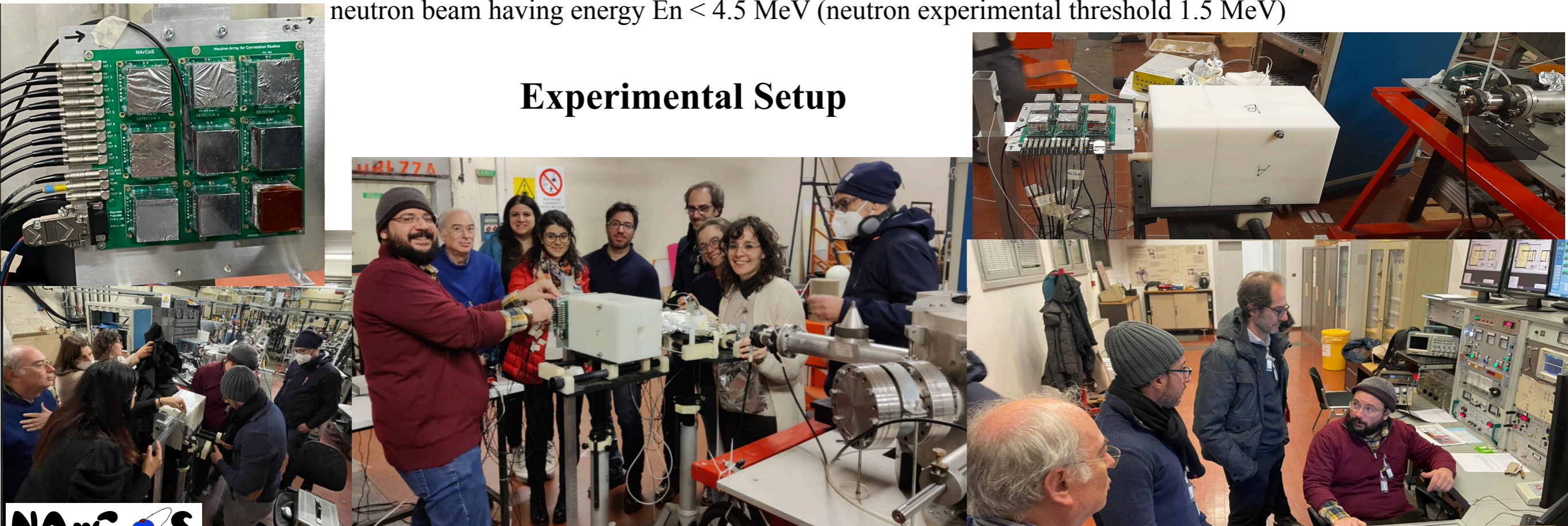

# Preliminary results of CROSSTEST exp. @LNL (end of 2023)

## Prototypal readout electronic

in coll. with INFN-MI (C. Boiano)

Each elementary cell of EJ276G (3x3x3 cm<sup>3</sup>) is equipped with a matrix of 25 SiPM (6x6 mm<sup>2</sup>) of 30 μm of thickness (≈ 40k microcells). The SiPM matrix is coupled with the plastic having their PAC and bias/temperature compensation circuit

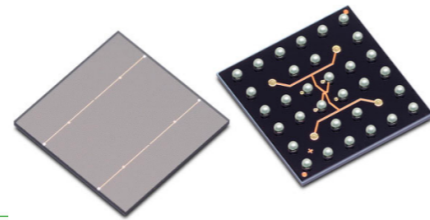
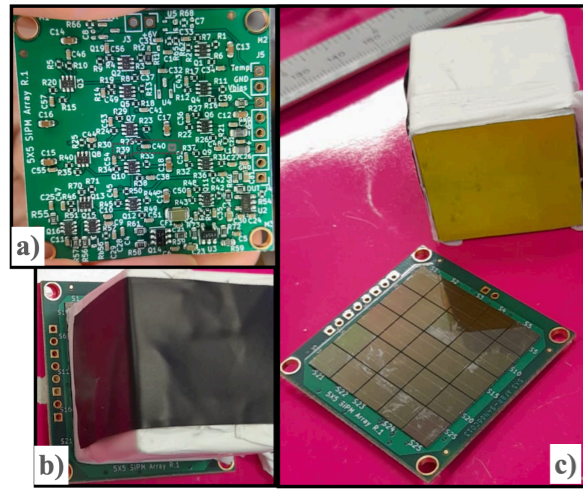

BROADCOM  
AFBR-S4N66C013

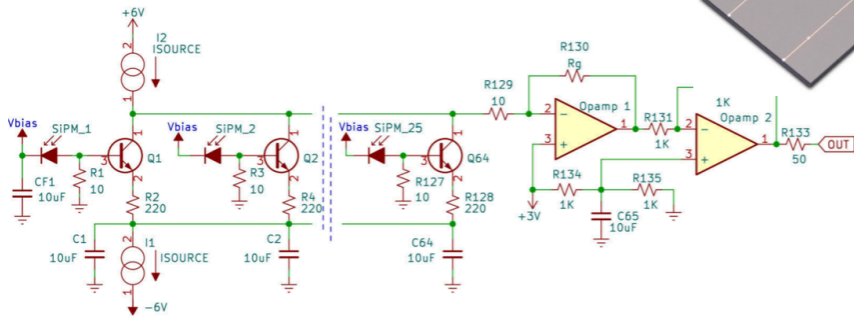

Electronic Board for housing the 9 elementary cells with its electronic readout boards, with the out of the signals, test ingress, temperature monitoring and bias ingress

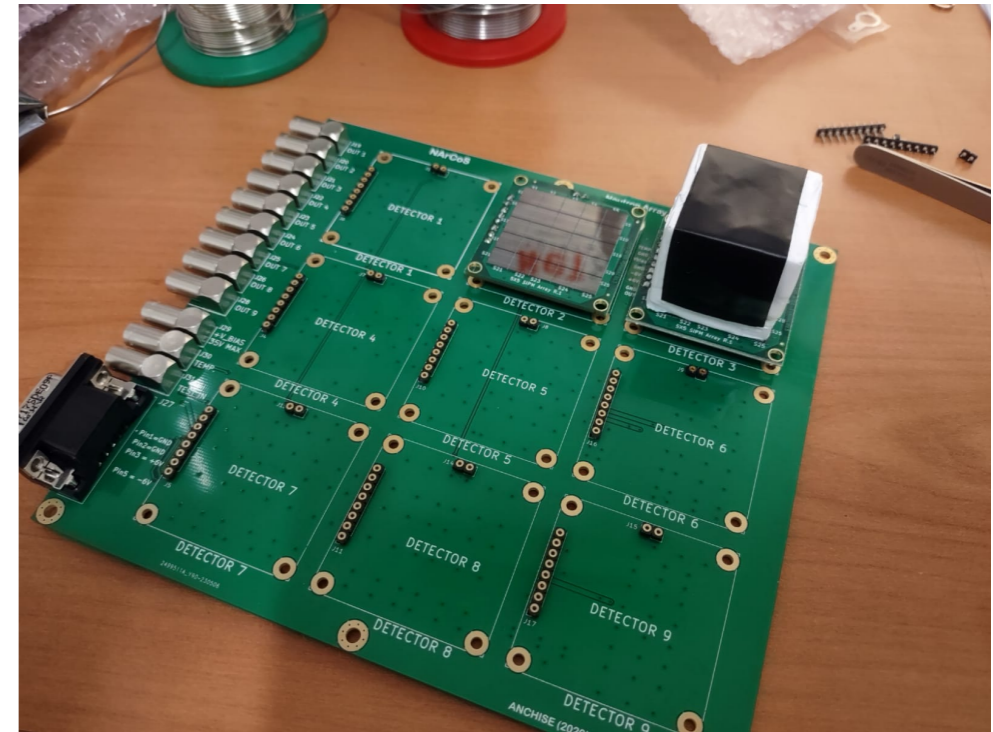

### FAST, SLOW, TOT, TOTAL, MAX, τ

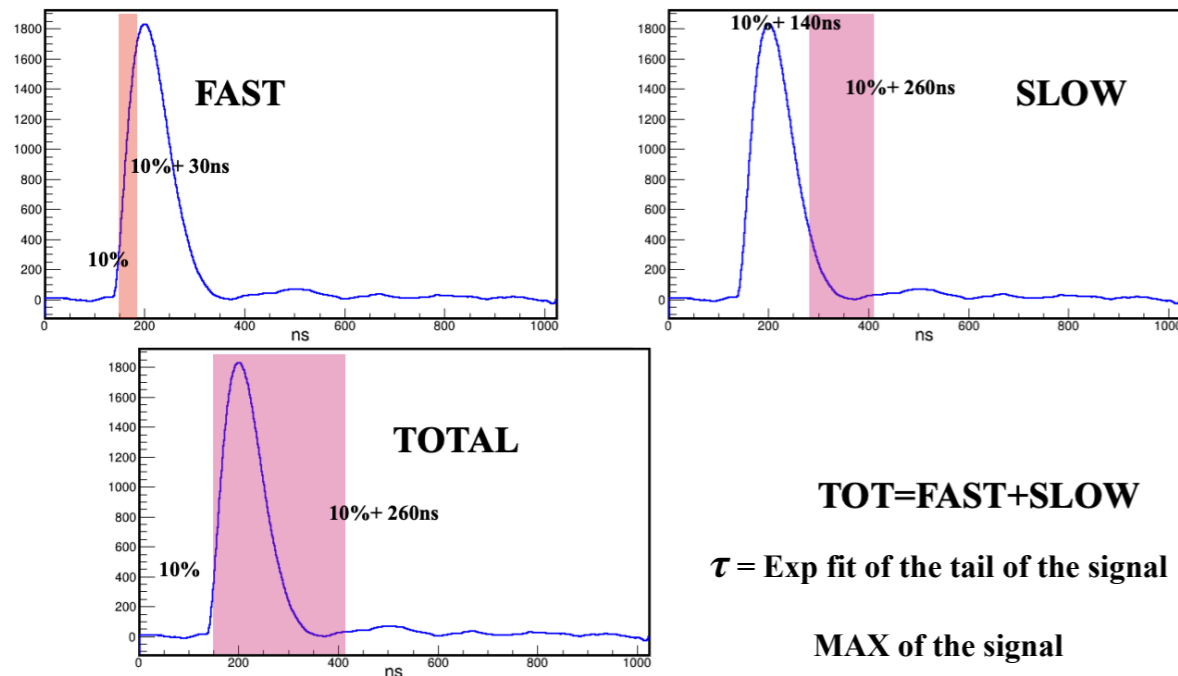

### Caen digitizer DT5742B\*

Sampling frequency: 1 Gs/s  
Trigger: internal (only the central plastic detector)



\* <https://www.caen.it/products/dt5742/>

# Preliminary results of CROSSTEST exp. @LNL (end of 2023)

## Detectors energy calibration

Calibration sources:  $^{22}\text{Na}$ ,  $^{60}\text{Co}$ ,  $^{137}\text{Cs}$ ,

Central plastic

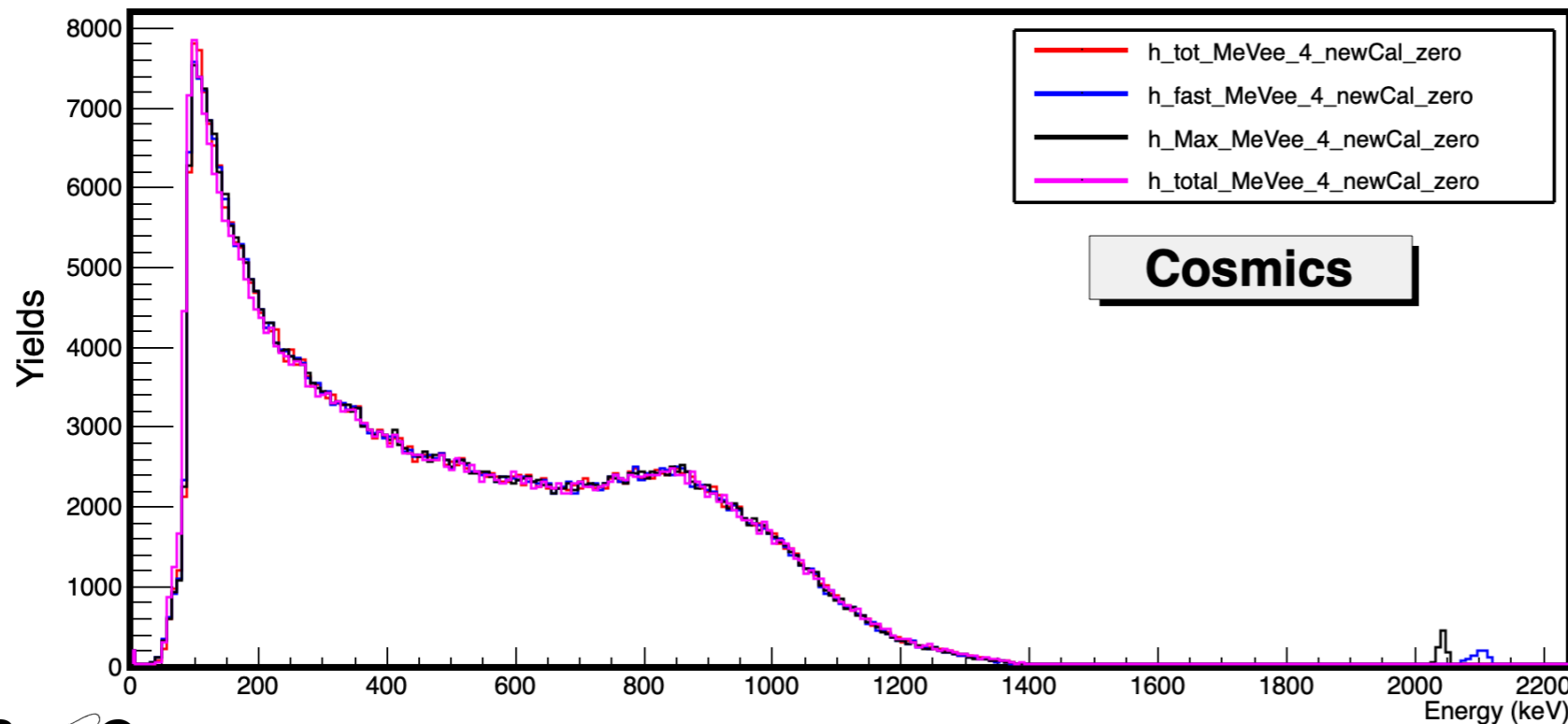
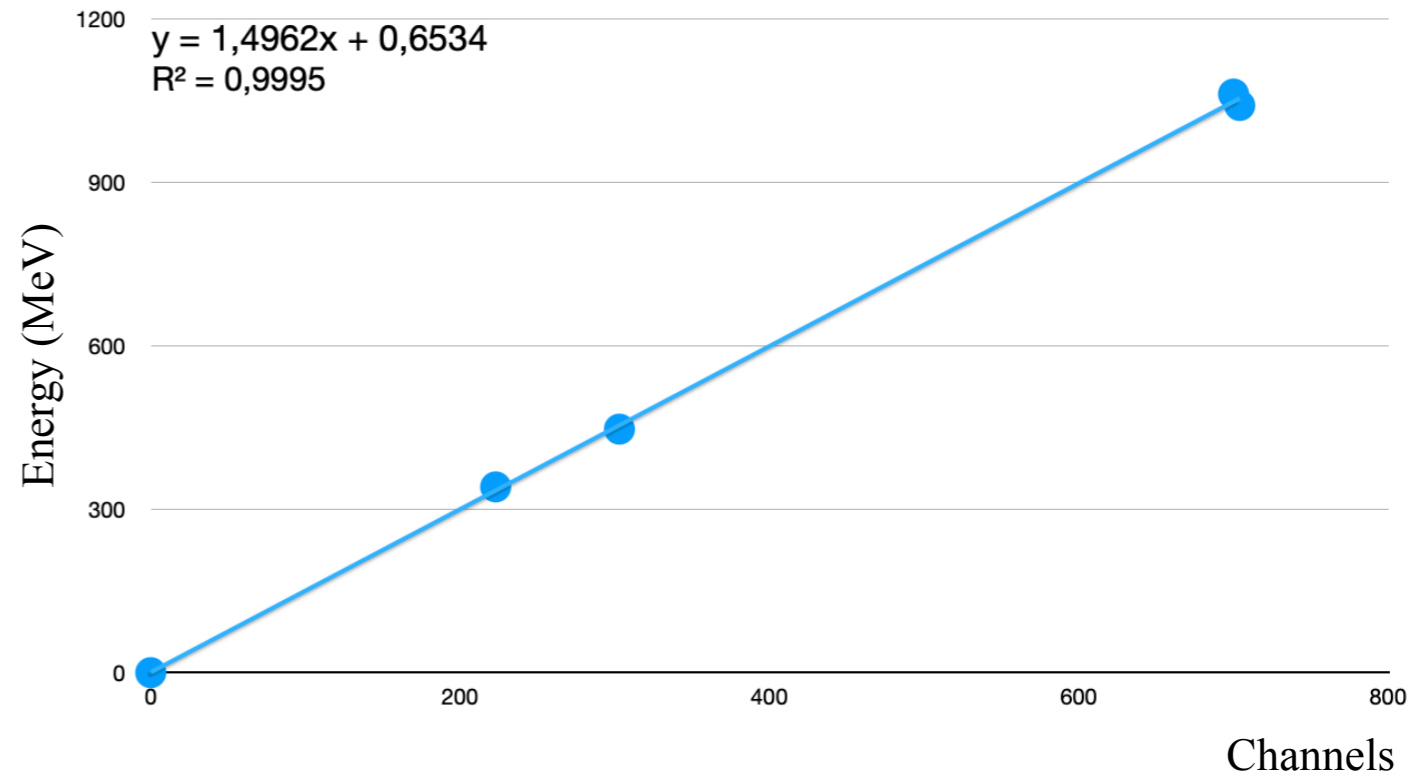
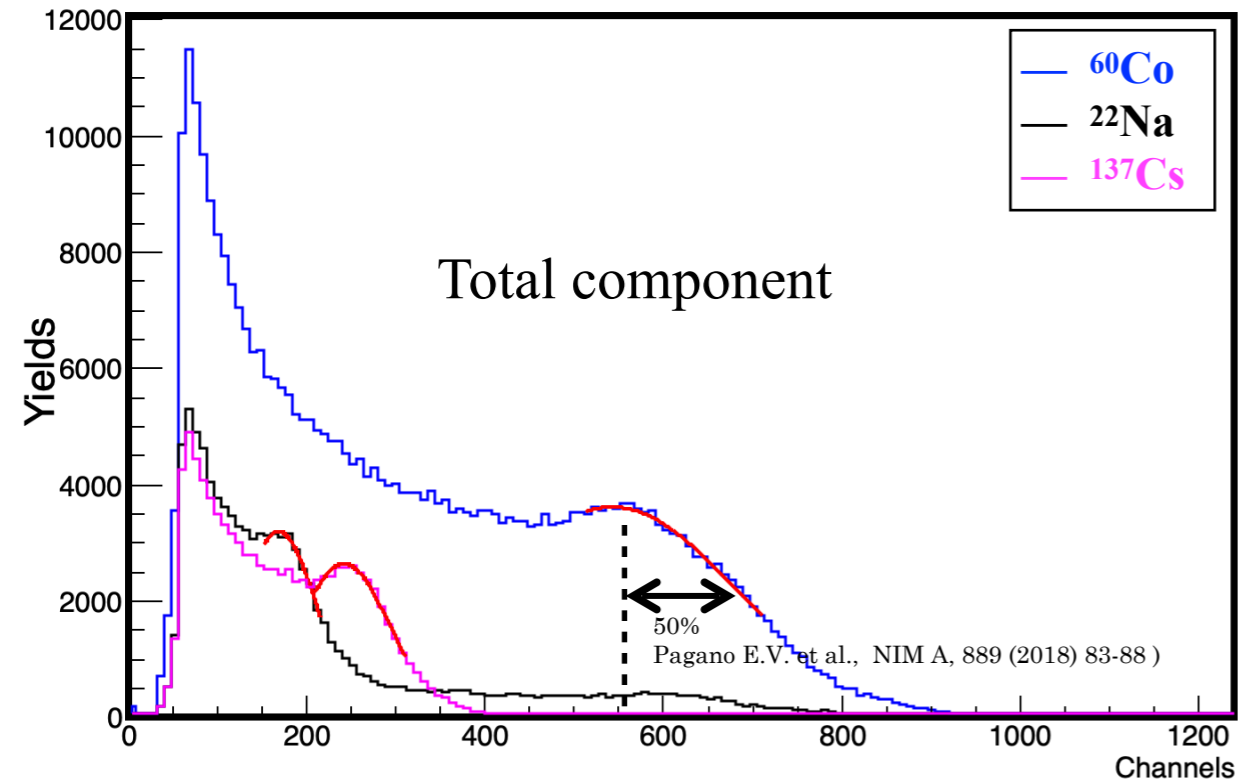

Good energy linearity  
Gamma rays energy threshold  $\approx 70$  keV

# Preliminary results of CROSSTEST exp. @LNL (end of 2023)

## Time resolution

evaluated with a cosmic ray detected in coincidence between two plastic scintillator

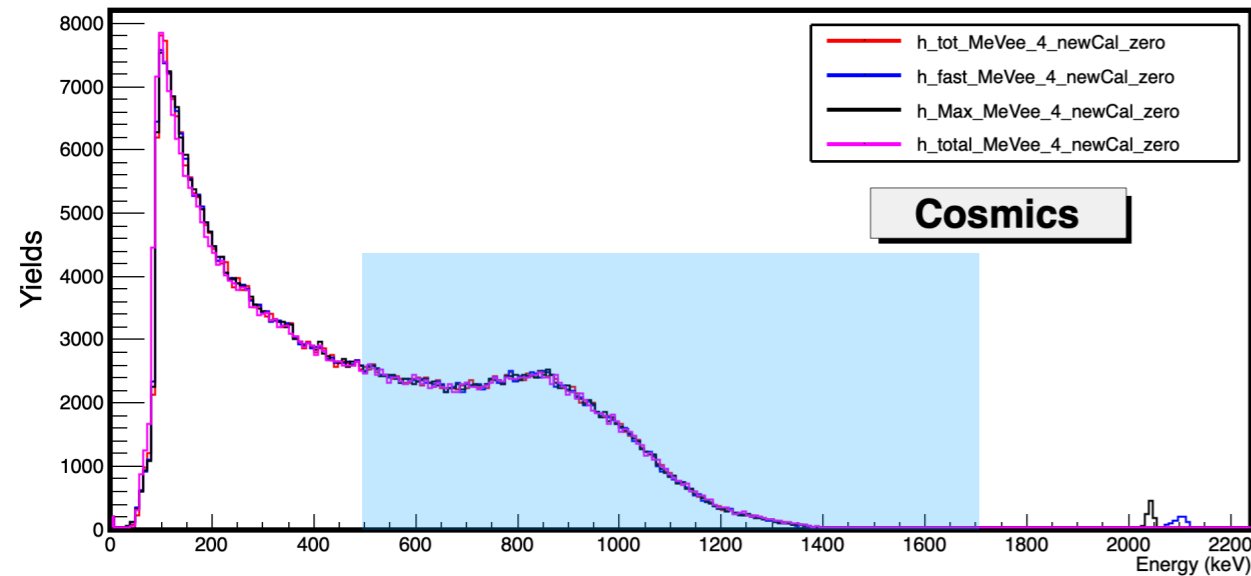

### Experimental conditions:

- Multiplicity = 2;
- Contiguity of the two hit plastic detectors
- Energy difference no larger of 20%
- Energy larger than 500 keV in each one

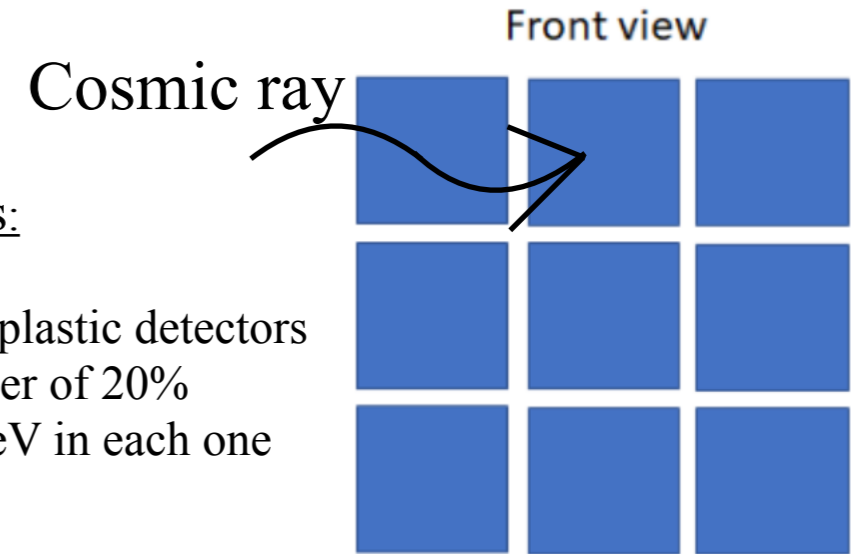

h\_Diff\_start\_cond

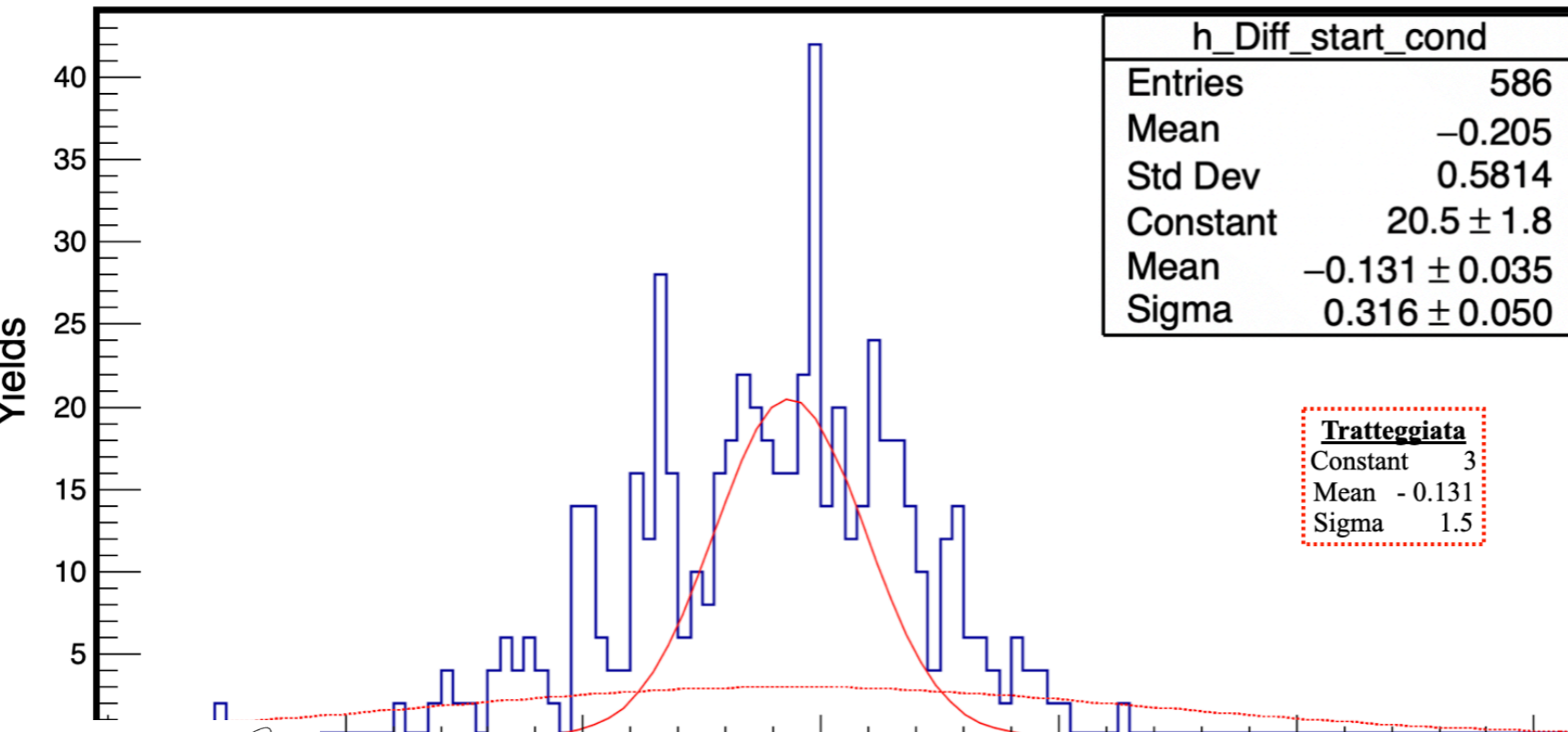

### Two Gaussian component in the spectrum

One real coincidence with a  $\sigma \approx 320$  ps and another of spurious coincidence with a  $\sigma \approx 1.5$  ns corresponding to about 10% of the selected events

Time resolution of one single green plastic

$$\sigma_{tot}^2 = 2\sigma_{green}^2 + \sigma_{el}^2 \rightarrow \sigma_{green} = \sqrt{\frac{\sigma_{tot}^2 - \sigma_{el}^2}{2}} \approx 215 \text{ ps}$$

$$\sigma_{el} \approx 100 \text{ ps}$$

**See Brunilde Gnoffo talk**



# Preliminary results of CROSSTEST exp. @LNL (end of 2023)

## 2D identification matrix

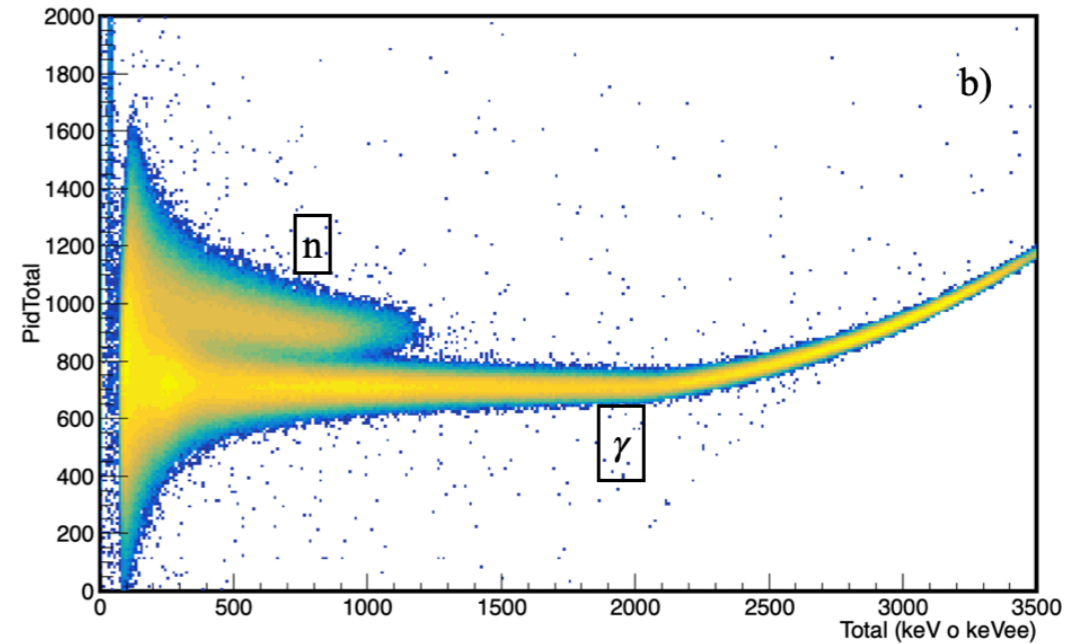
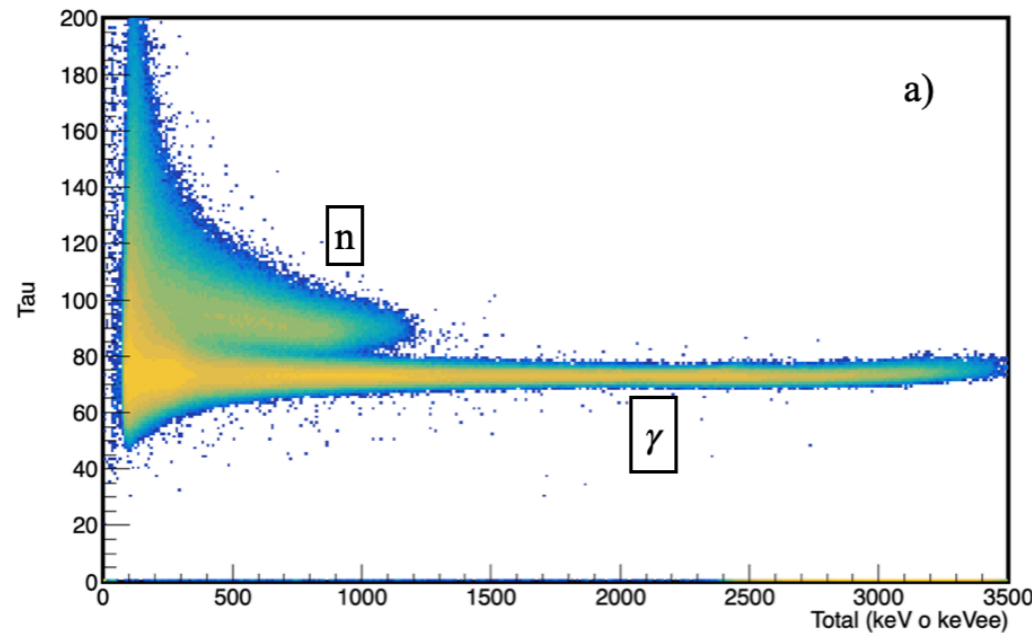

Matrici di identificazione 2D ottenute dal plastico centrale nella "schedona" posta a conf. a matrice

- a) Tau Vs del Total (keV)
- b) PidTotal VS Total (keV)
- c) PidTot Vs Tot (keV)

Tau: fit esponenziale nella parte decrescente del segnale  
PidTotal: Slow/Total\*  
PidTot: Slow/Tot\*

Central plastic

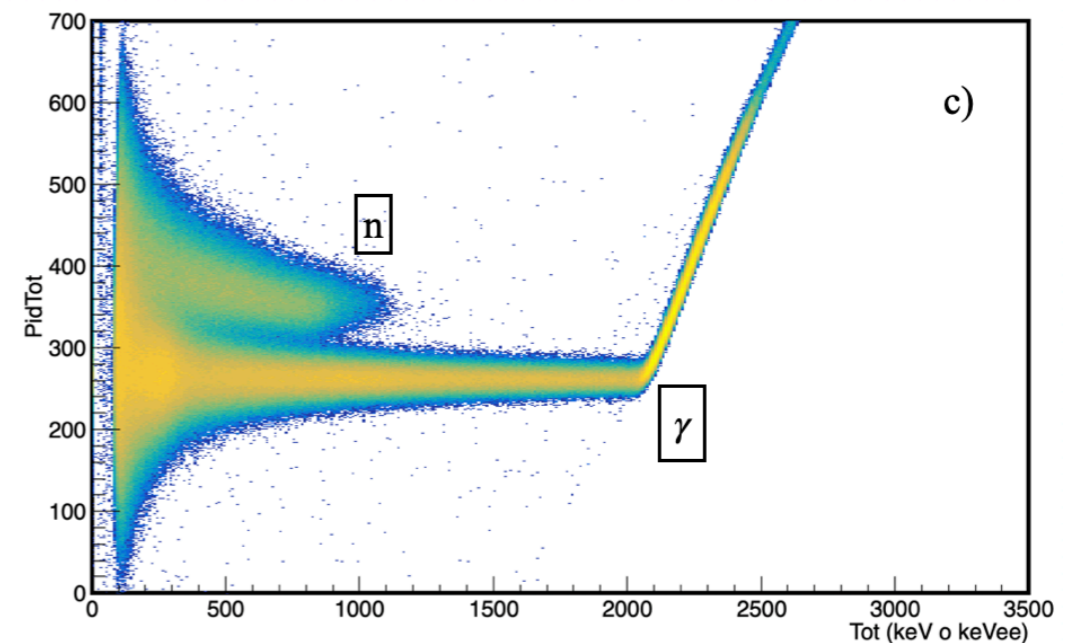

Three different 2D identification matrix was analyzed in order to study the detector performances

# Preliminary results of CROSSTEST exp. @LNL (end of 2023)

## Neutron and Gammas selection

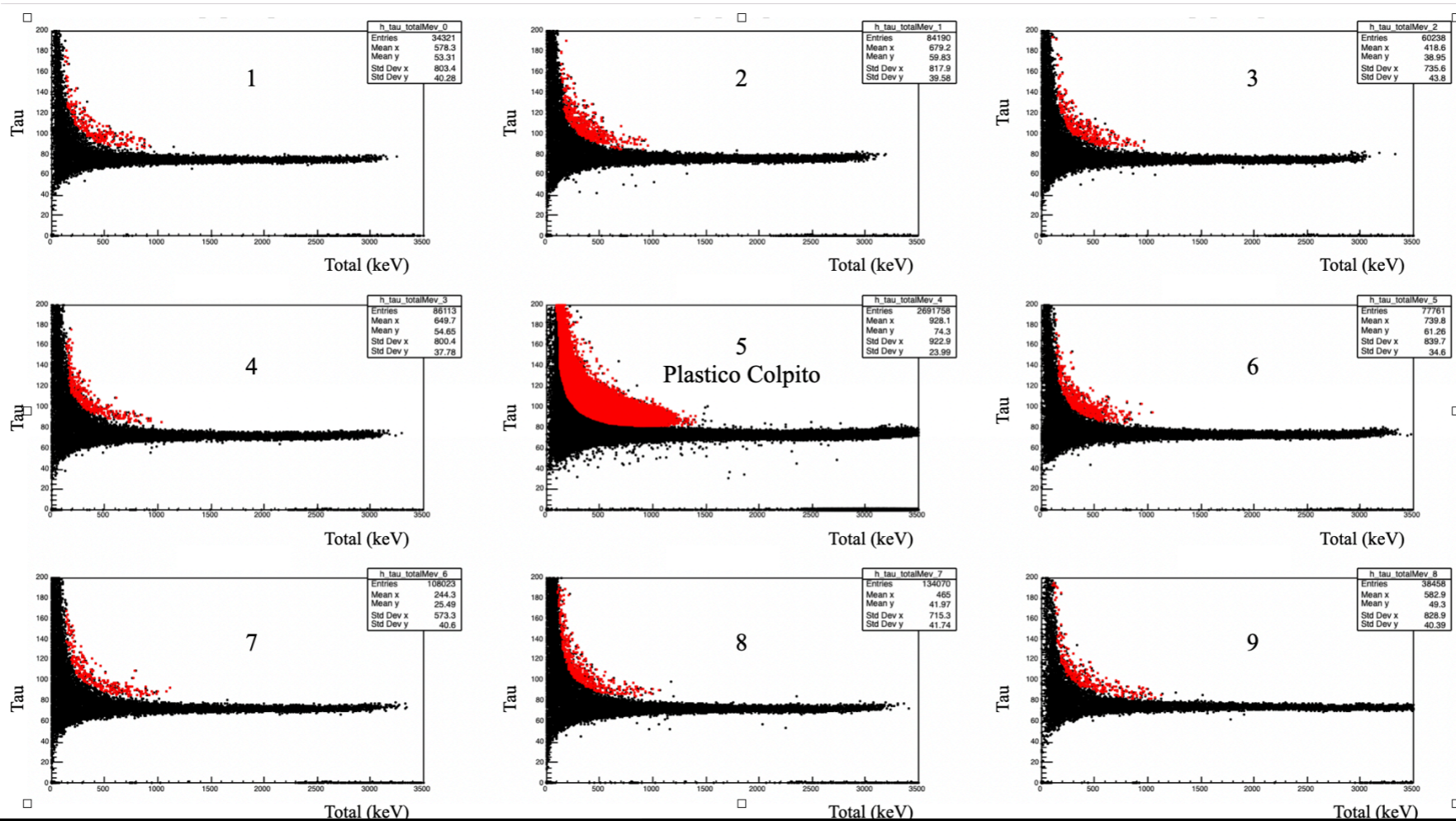
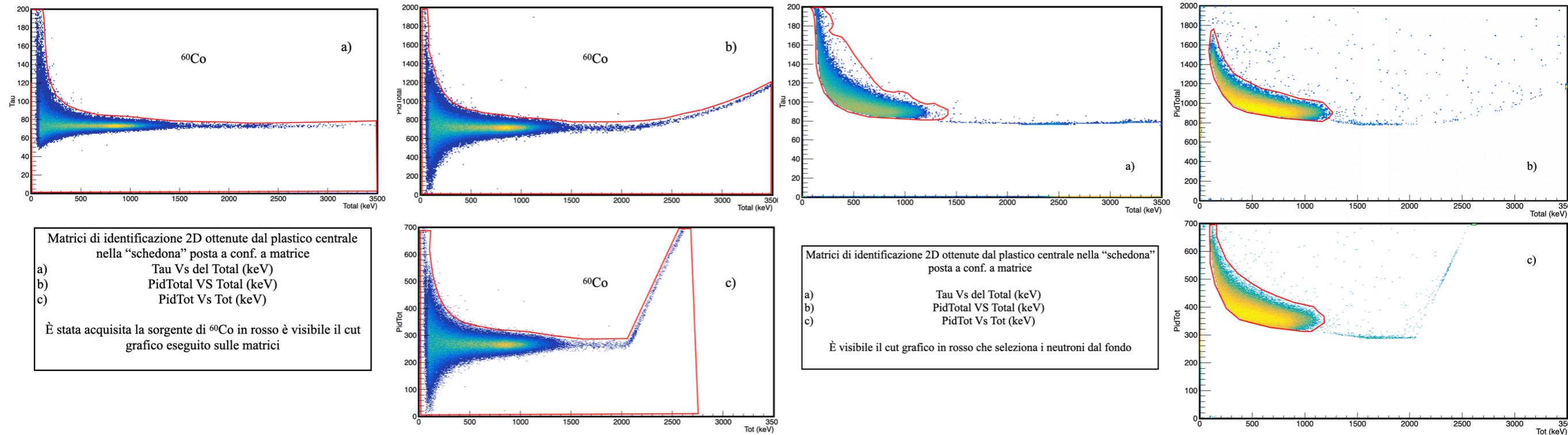

# Preliminary results of CROSSTEST exp. @LNL (end of 2023)

## Neutron spectra

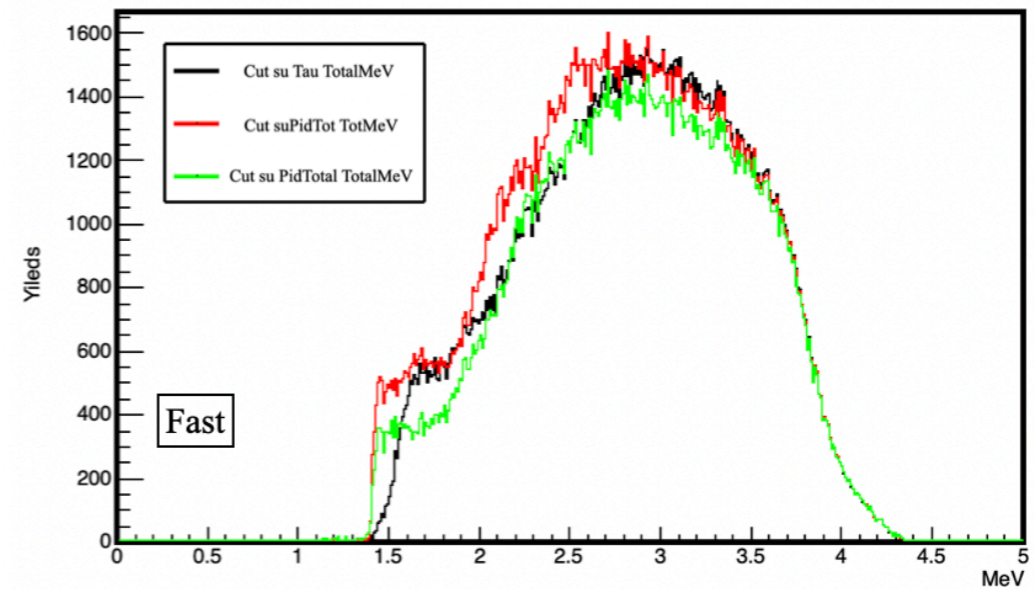
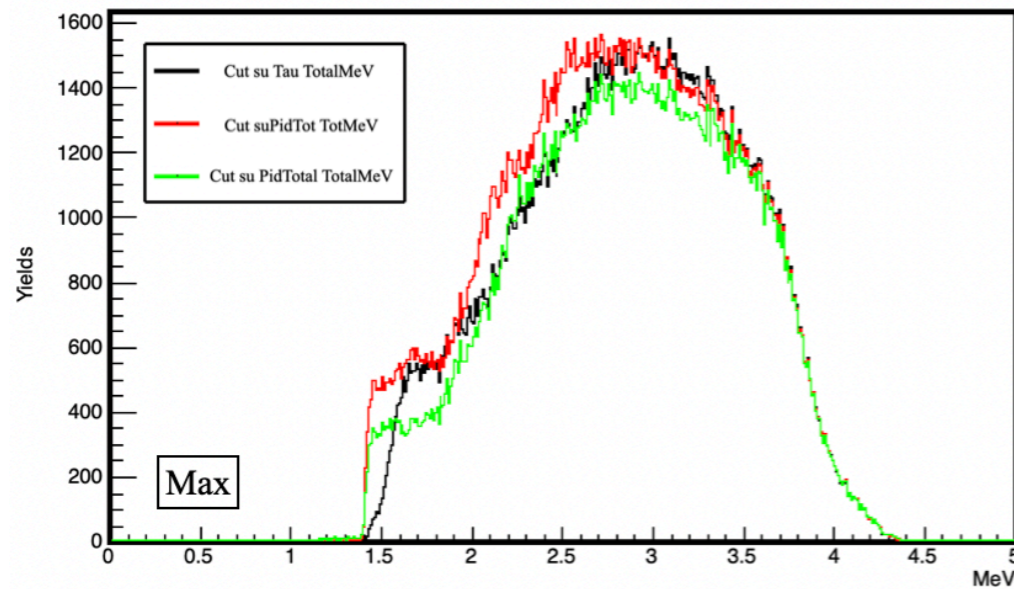
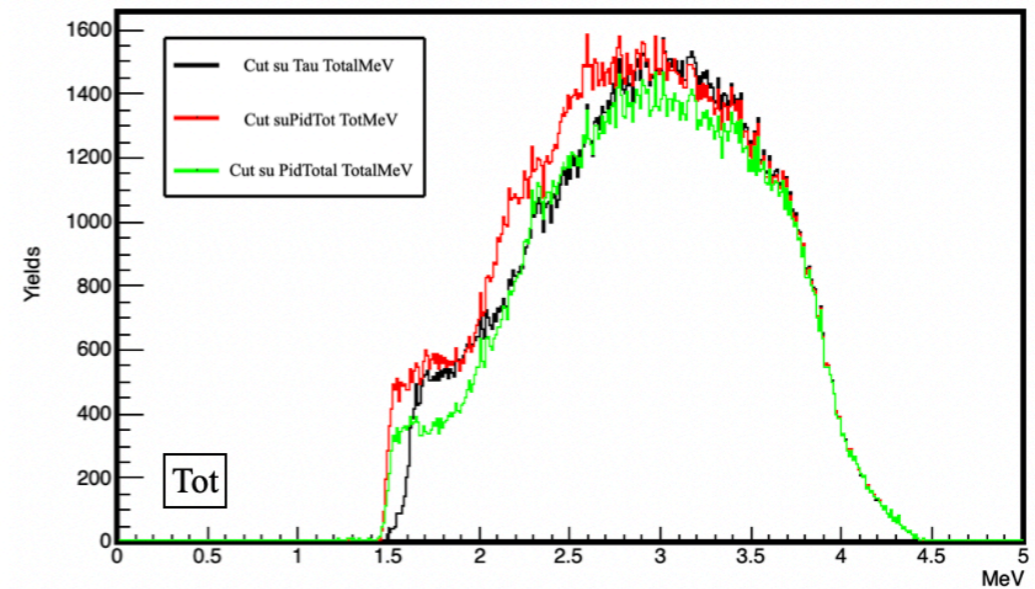
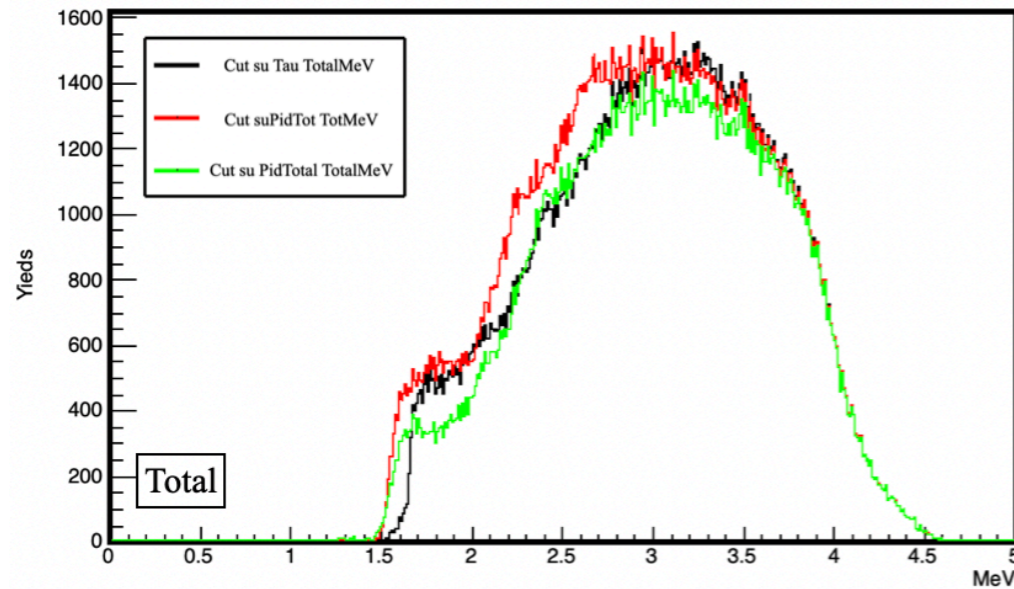

Form MeVee to MeV:

$$L_{out} = aE_{dep} - b[q - e^{-cE_{dep}}]^*$$

\*Lawrence et al. NIM A 759 (2014) 16-22

$a = 0.8 \text{ MeVee} \cdot \text{MeV}^{-1}$   
 $b = 0.39 \text{ MeVee}$   
 $c = 0.22 \text{ MeV}$   
 $L_{out}$  in MeVee  
 $E_{dep}$  in MeV

Reasonable neutron energy spectra (neutron beam maximum energy 4.5MeV), robust energy calibration as a function of the variable, robust neutron selection as a function of the three 2D identification matrix, about 1.5 MeV of neutron energy threshold

# Preliminary results of CROSSTEST exp. @LNL (end of 2023)

## FoM and Errors estimations

Very close results for the others 2D Identification Matrix

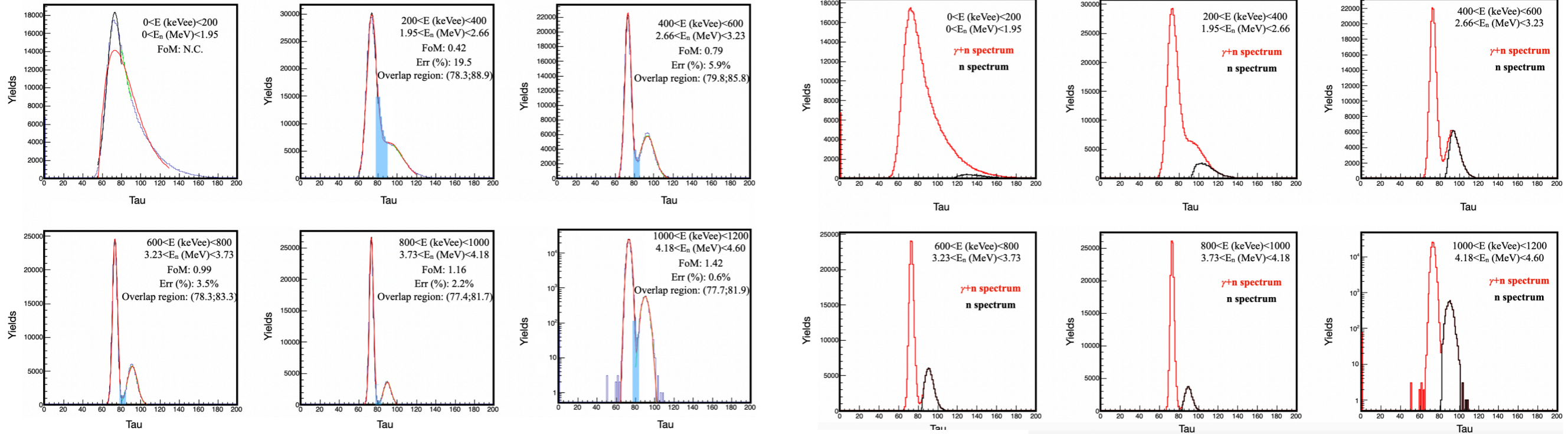

Tau Vs Total 2D identification matrix

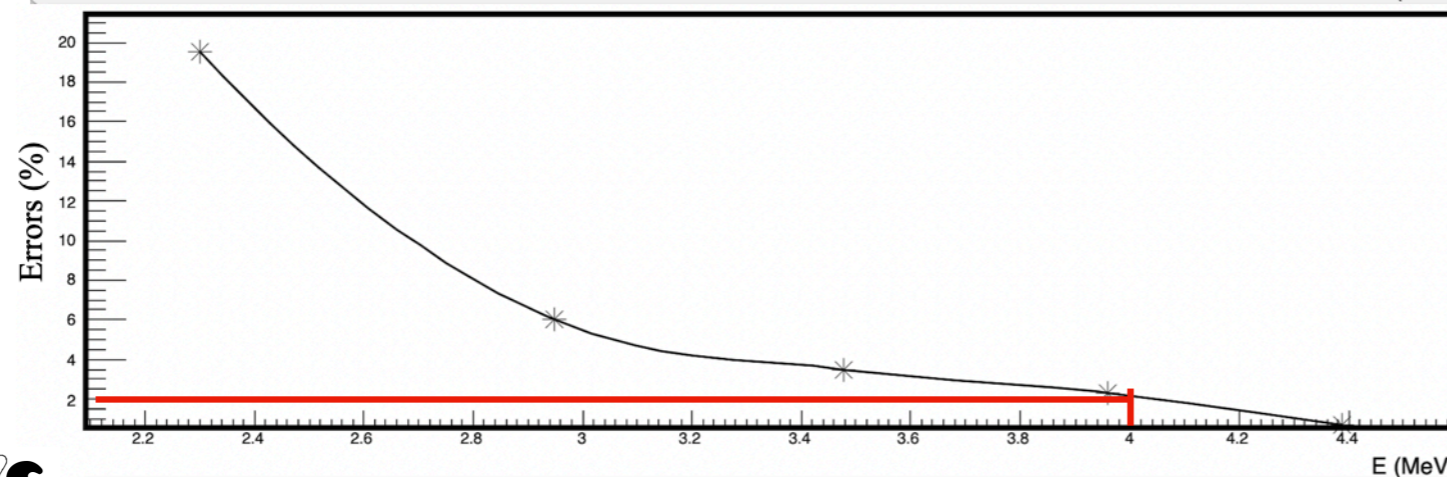
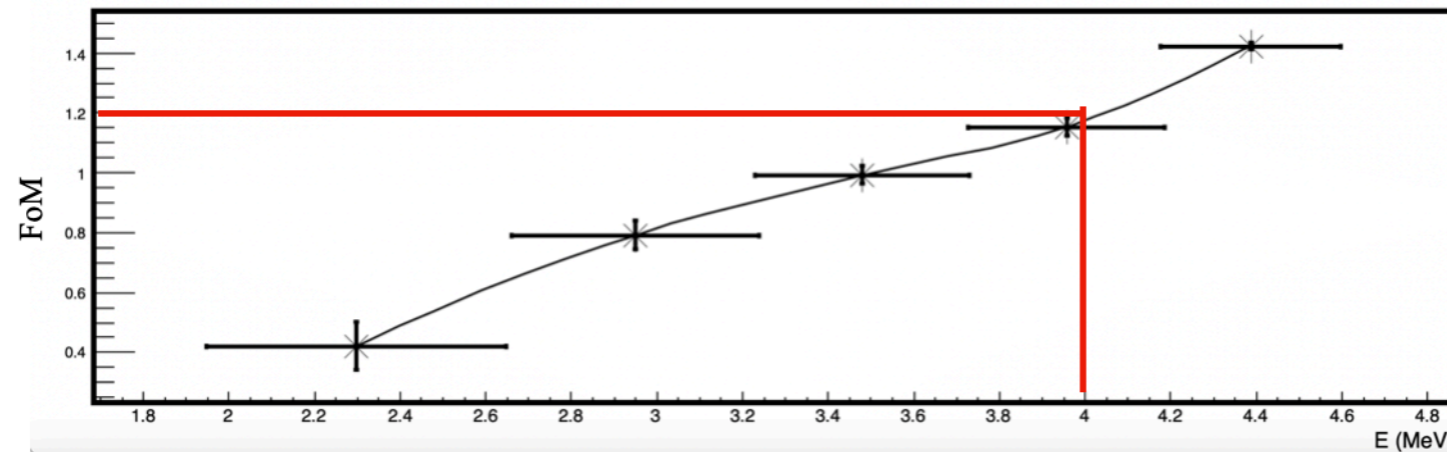

At about 4 MeV of neutrons we obtain a value of 1.2 of FoM generally considered as “good”. At this value the corresponding errors in the neutron identification is about 2%

# Preliminary results of CROSSTEST exp. @LNL (end of 2023)

## Crosstalk Measurement for 4.5 MeV of neutrons

### Matrix configuration (surface crosstalk)

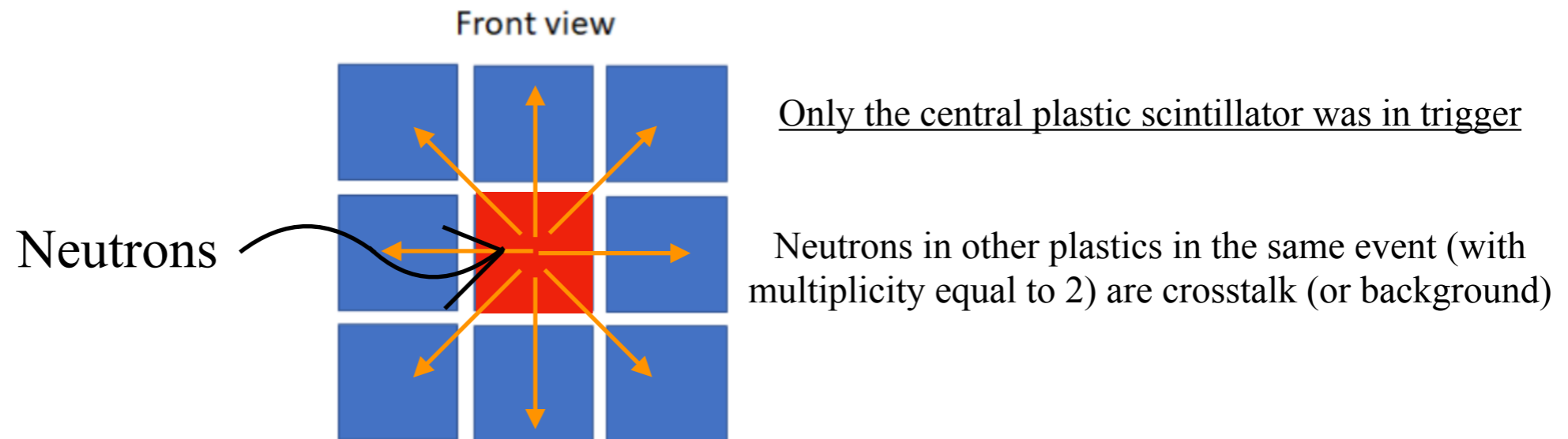

Crosstalk probability:  $\frac{\text{number of neutrons non in trigger}}{\text{number of neutron in trigger (central)}} \times 100 \%$

$$P (\%) = \text{prob} (\%) \pm Er_{ass} (\%) = (0.117 \pm 0.008) \%$$

$$P (\%) \approx 0.1 \%$$

# Preliminary results of CROSSTEST exp. @LNL (end of 2023)

## Crosstalk Measurement for 4.5 MeV of neutrons

### Cluster configuration (linear crosstalk)

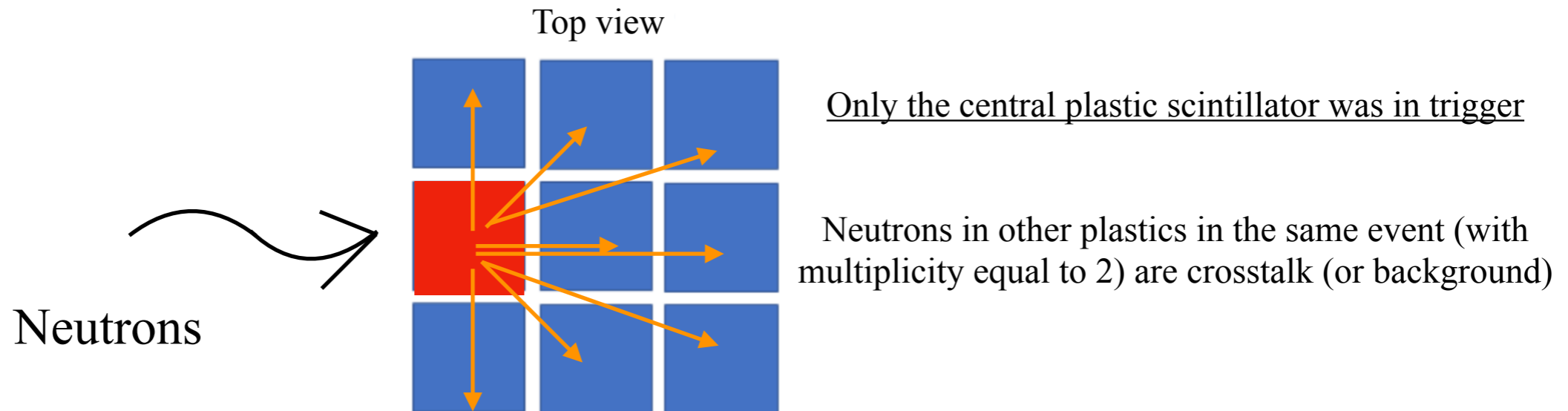

Crosstalk probability: 
$$\frac{\text{number of neutrons non in trigger}}{\text{number of neutron in trigger (central)}} \times 100 \%$$

$$P (\%) = \text{prob} (\%) \pm Er_{ass} (\%) = (0.163 \pm 0.005) \%$$

$$P (\%) \approx 0.2 \%$$

# Preliminary results of CROSSTEST exp. @LNL (end of 2023)

## Crosstalk Measurement and comparison with MC based simulation

The simulated value was obtained form GEANT4 toolkit simulation (G. Santagati and L. Quattrocchi)

And from MCNPX toolkit simulation (L. Quattrocchi)

The two simulation software were in good agreement

Value for Neutrons of 4.5 MeV

Conf.	Measured crosstalk Probability	Measured Error	Measured Error (%)	GEANT4 crosstalk Probability	GEANT4 error	GEANT4 error (%)	Difference
MATRICE	0,117	0,008	7	0,45	0,06	13	0,333
CLUSTER	0,163	0,005	3	1,37	0,07	5	1,207

The difference from measured to the respect of the simulated values are not so big in absolute value but large un relative!

A factor 4 in for the matrix configuration

An order of magnitude for the cluster configuration

More investigation are needed

# Conclusions and perspectives

The CROSSTEST experiment was performed in November 2023 at the CN accelerator at LNL-INFN using a neutron beam of 4.5 MeV of maximum energy from a proton primary beam of 4.5 MeV impinging on a LiF target.

The prototypal electronics of readout able to read a matrix of 25 SiPM for each plastic scintillator (EJ276G) worked with good performances.

The preliminary results obtained so far are encouraging: a very good and linear energy calibration of several variable acquired was obtained, good separation between neutron and gamma with a FoM of 1.2 at 4 MeV of neutrons with three different 2D identification matrix, a neutron threshold of 1.5 MeV, a gamma threshold of 70 keV and a time resolution of 320 ps was achieved for 2 plastic scintillator and the electronics (assumable 220 ps for one scintillator and the electronics).

The crosstalk valute at 4.5 MeV of neutrons was measured for the matrix configuration is about  $P(\%) = 0.1\%$  and for the cluster configuration is about  $P(\%) = 0.2\%$ .

Thees value are relatively far from the MC based simulation (GEANT4 and MCMPX) or the matrix configuration is about  $P(\%) = 0.5\%$  and for the cluster configuration is about  $P(\%) = 1.4\%$ .

New test are on going at LNS-INFN in order to measure the time resolution and the possible time delay between the two versions of the plastic scintillators (EJ276G and EJ276). See B. Gnoffo talk.

New experiments have to be performed in order to test the crosstalk at higher neutron energies in Catania at LNS-INFN and in Legnaro at LNL-INFN.

The study of the mechanical configuration of the NArCoS prototype is ongoing.

An extension of the study for the efficiency and for the crosstalk problem for the prototype in its final configuration has to be done by means of GEANT4 and MCNPX



## For more info see :

- 1) Pagano E.V. et al., N.S., Nucl. Instrum. Methods A, 889 (2018) 83–88
- 2) Pagano E.V. et al., N.S., Nucl. Instrum. Methods A, 905 (2018) 47–52
- 3) Pagano E.V. et al., IL NUOVO CIMENTO 41 C (2018) 181
- 4) Pagano E.V. et al., JPS Conf. Proc. 32, 010096 (2020)
- 5) Pagano E.V. et al., IL NUOVO CIMENTO 43 C (2020) 12
- 6) Pagano E.V. et al., J. Phys.: Conf. Ser. 1643 (2020) 012037
- 7) Pagano E.V. et al., IL NUOVO CIMENTO 45 C (2022) 64
- 8) Pagano E.V. et al., Front. Phys. 10:1051058
- 9) Pagano E.V. et al., LNS Report (2022)
- 10) Pagano E.V., G. Politi, A. Simancas et al., Nucl. Instrum. Methods A 1064 (2024) 169425
- 11) Santagati G., Pagano E.V. et al., RAD Conference Proceedings, vol. 7, pp. 52–58, 2023
- 12) Santagati G., Pagano E.V. et al., IL NUOVO CIMENTO C, vol. 48, (2025) 13
- 13) Pagano E.V. et al., IL NUOVO CIMENTO C, vol. 48, (2025) 12
- 14) Quattrocchi L., Gnoffo B., Pagano E.V. et al., (Proceedings of the International Conference Applied Nuclear Physics 2024 to be published)
- 15) Gnoffo B., Pagano E.V. et al., on timing performances in preparations
- 16) Pagano E.V. et al., on croostalk al 4.5 MeV neutron in preparation

## Thanks for the attention