

Slew rate analysis for time walk correction with ALCOR

B Rajesh Achari

University and INFN Bologna

ePIC collaboration meeting 2025

Jan 20, 2025

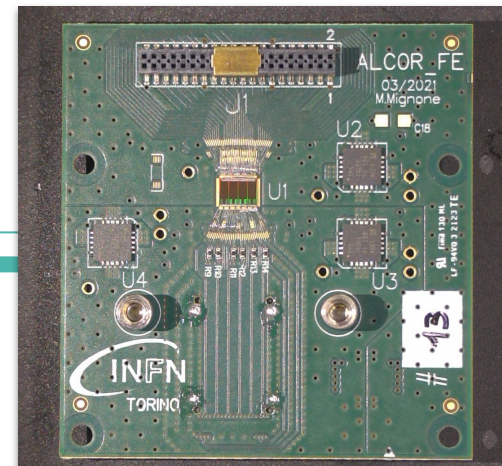
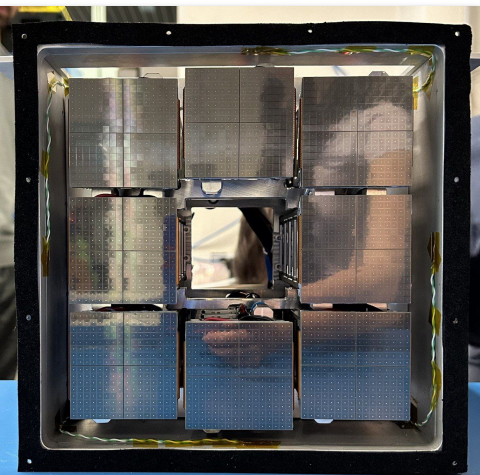

The dual-radiator RICH Detector for forward PID at ePIC

Compact and cost-effective solution for broad momentum
(3-50 GeV/c) coverage at forward rapidity

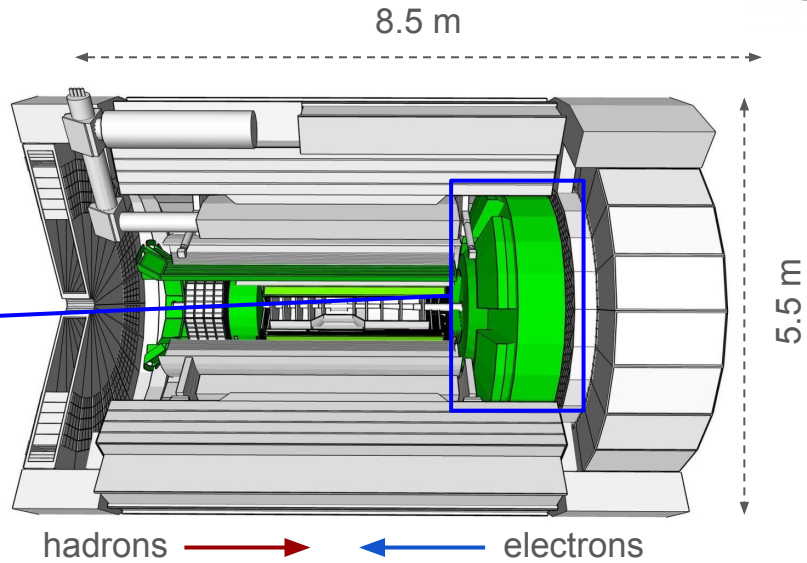
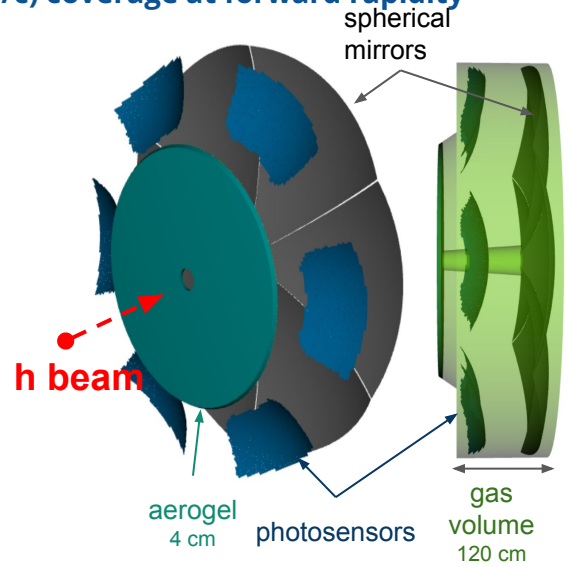

Total **319488 photosensors** with TDC readout

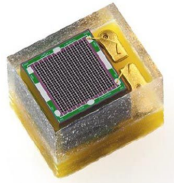

SiPMs

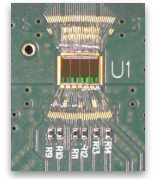

ALCOR

SiPMs are chosen for optical readout

- Compact and cost effective
- Resistive to high B field (~ 1 T)
- Single photon sensitivity
- **Cons:**
 - High dark count rate (DCR)
 - Radiation intolerant

Technical solutions and mitigation strategy:

- Cooling
- Annealing
- **timing**

timing is important to correlate the detected photon with the interaction event to exclude DCR

SiPM output waveform and time walk?

SiPM signals have similar shapes, but their amplitudes vary based on the number of pixels that fire simultaneously. This results in pulses with proportional amplitudes.

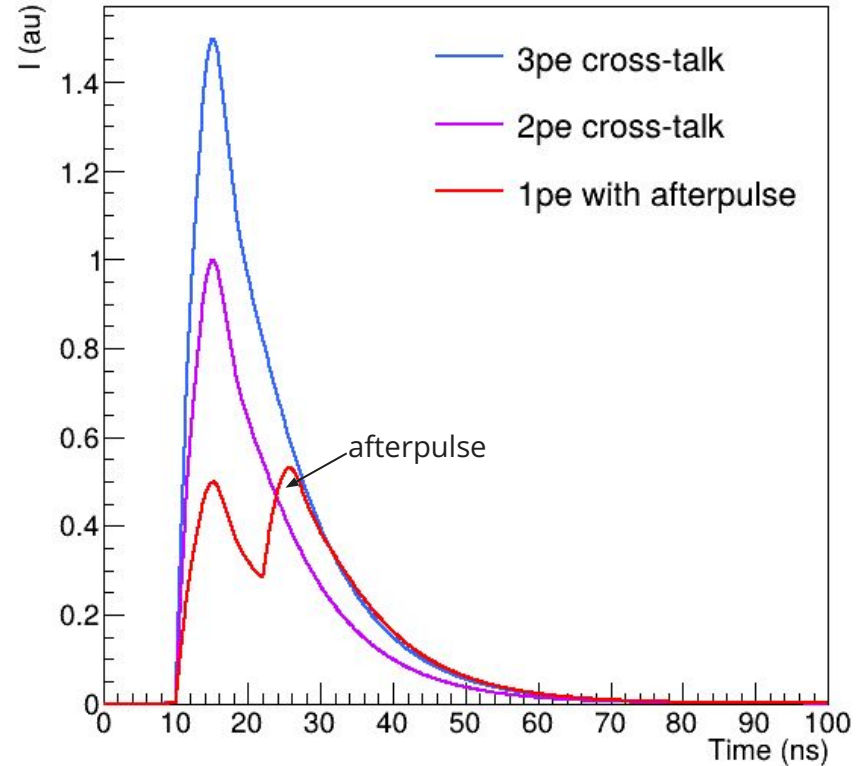

SiPM output waveform and time walk?

SiPM signals have similar shapes, but their amplitudes vary based on the number of pixels that fire simultaneously. This results in pulses with discrete proportional amplitudes.

- Signals with higher amplitudes reach a fixed threshold earlier than those with lower amplitudes cross the same threshold later.
- **Time walk** refers to the **systematic shift** in the recorded timing of a signal due to differences in amplitude, when you have electronics with fixed threshold discriminator.
- This amplitude-dependent timing error introduces inaccuracies that affect the precision of time measurements in SiPM signals.

If we rely solely on the **time of arrival (ToA)** information, it is impossible to correct for time walk effectively. This inspires us to switch to other **modes of ALCOR**.

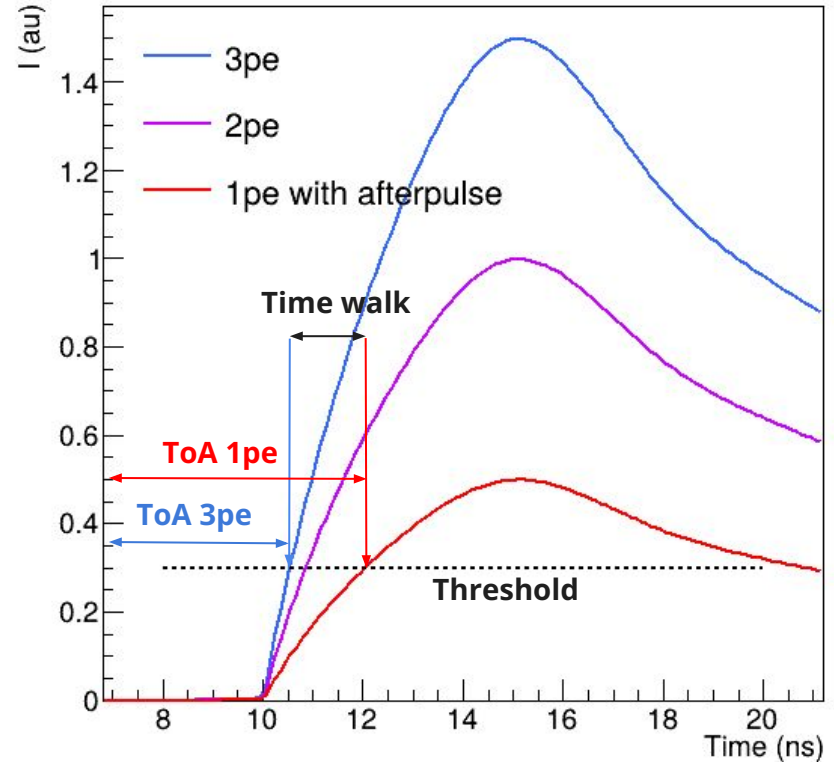

Observation on ToT mode and SR mode

<https://doi.org/10.1016/j.nima.2024.169817>

- **hit - reference time (ΔT) = Time of Arrival (ToA)**
- **Time-over-Threshold (ToT) mode:** records the time duration a signal stays over a particular threshold

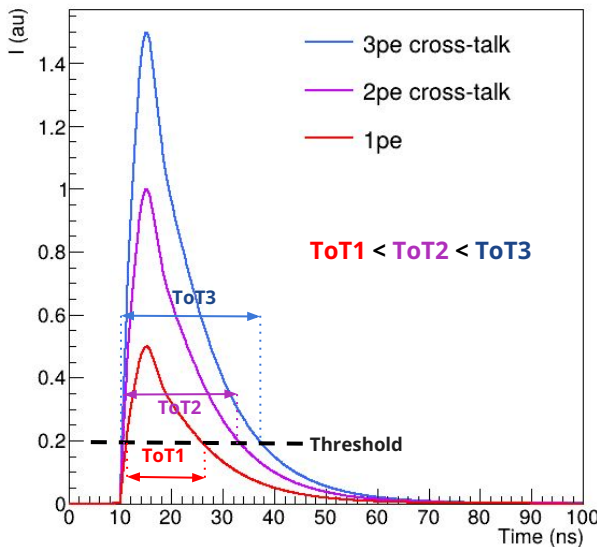

Time-over-Threshold mode

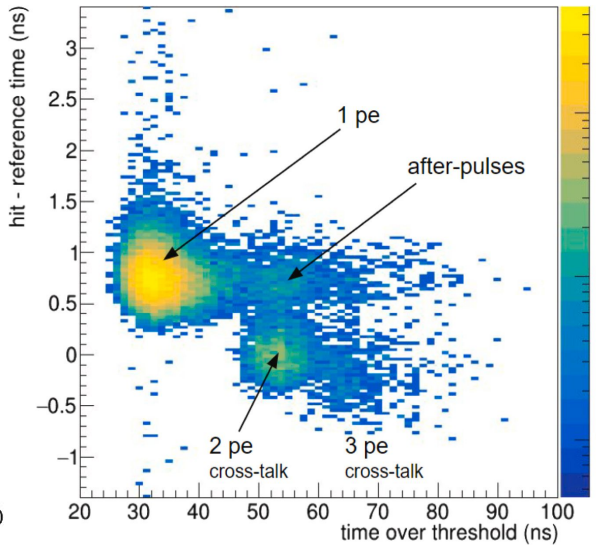

Slew-rate mode

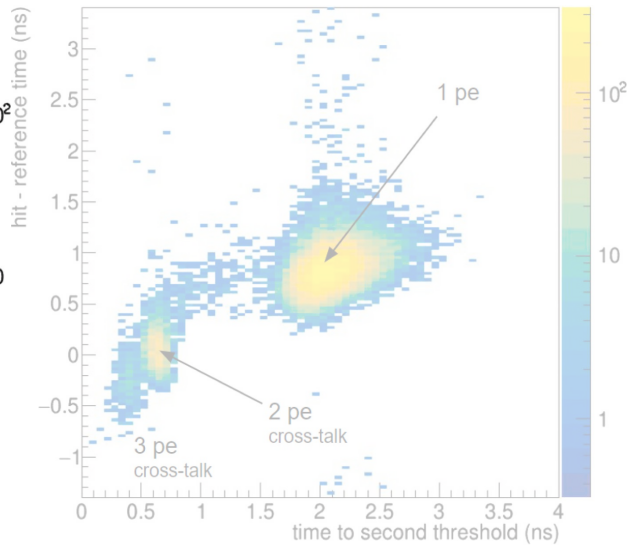

In ToT mode, there are some cases in which after-pulses are merged to the 1pe signal, hence the ToT value is larger and might not be distinguished from the cross-talk events.

Observation on ToT mode and SR mode

<https://doi.org/10.1016/j.nima.2024.169817>

- **hit - reference time (ΔT) = Time of Arrival (ToA)**
- **Time-over-Threshold (ToT) mode:** records the time duration a signal stays over a particular threshold

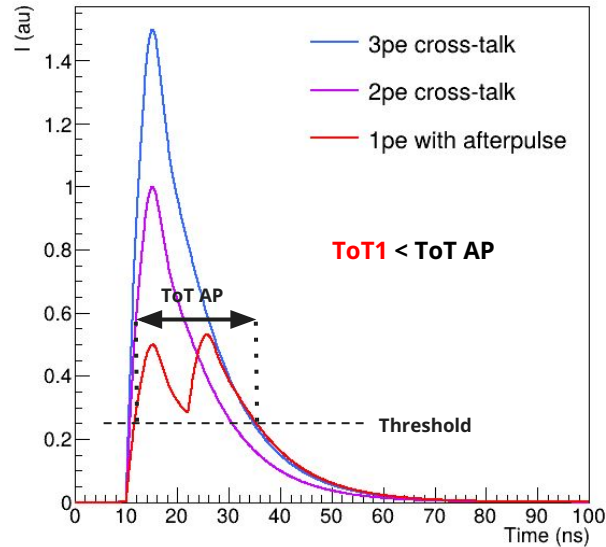

Time-over-Threshold mode

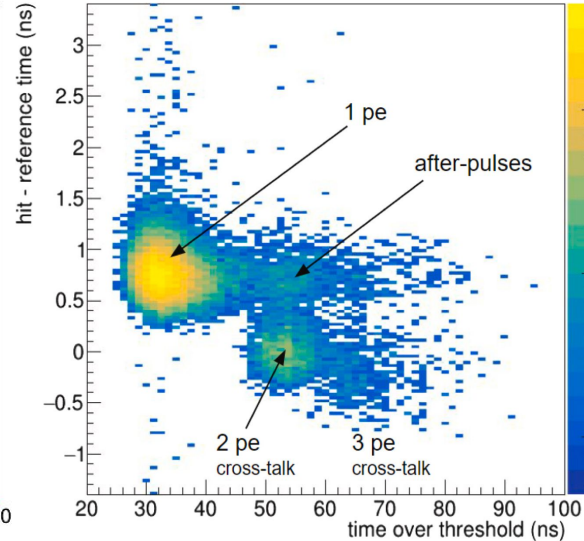

Slew-rate mode

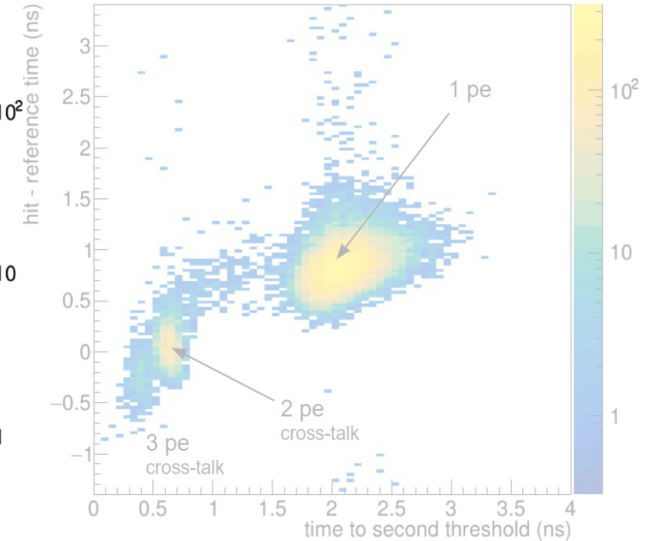

In ToT mode, there are some cases in which after-pulses are merged to the 1pe signal, hence the ToT value is larger and might not be distinguished from the cross-talk events.

Observation on ToT mode and SR mode

<https://doi.org/10.1016/j.nima.2024.169817>

- **hit - reference time (ΔT) = Time of Arrival (ToA)**
- **Time-over-Threshold (ToT) mode:** records the time duration a signal stays over a particular threshold
- **Slew-rate (SR) mode:** two discriminators record the **time stamp only on the rising edge of the signal** and measures the time to reach to the second threshold (**2nd threshold - 1st threshold = time to second threshold (TsT)**).

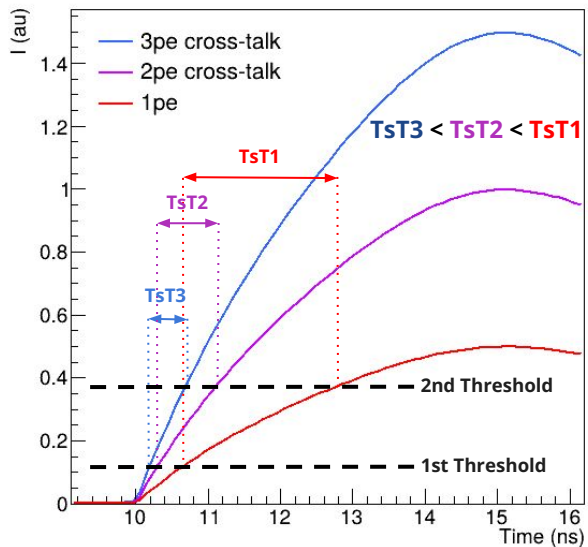

Time-over-Threshold mode

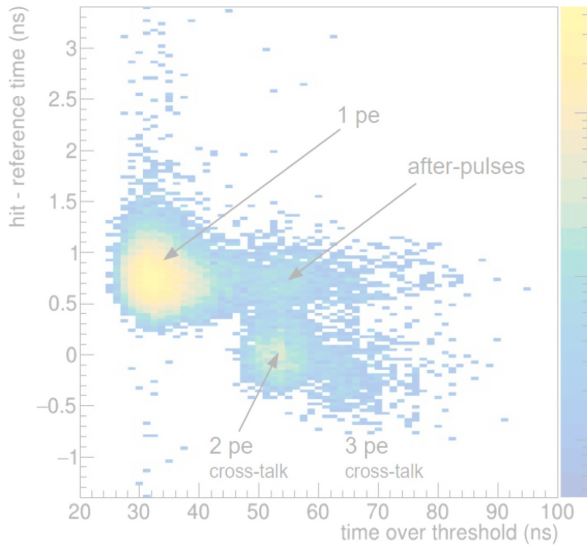

Slew-rate mode

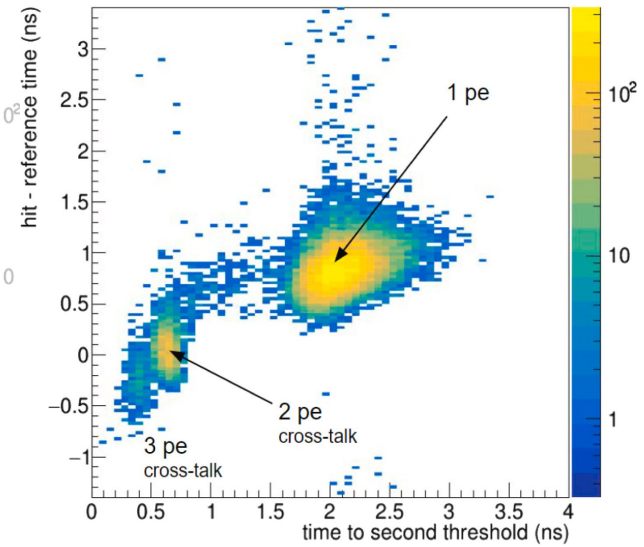

In ToT mode, there are some cases in which after-pulses are merged to the 1pe signal, hence the ToT value is larger and might not be distinguished from the cross-talk events.

Threshold scan in Slew Rate mode

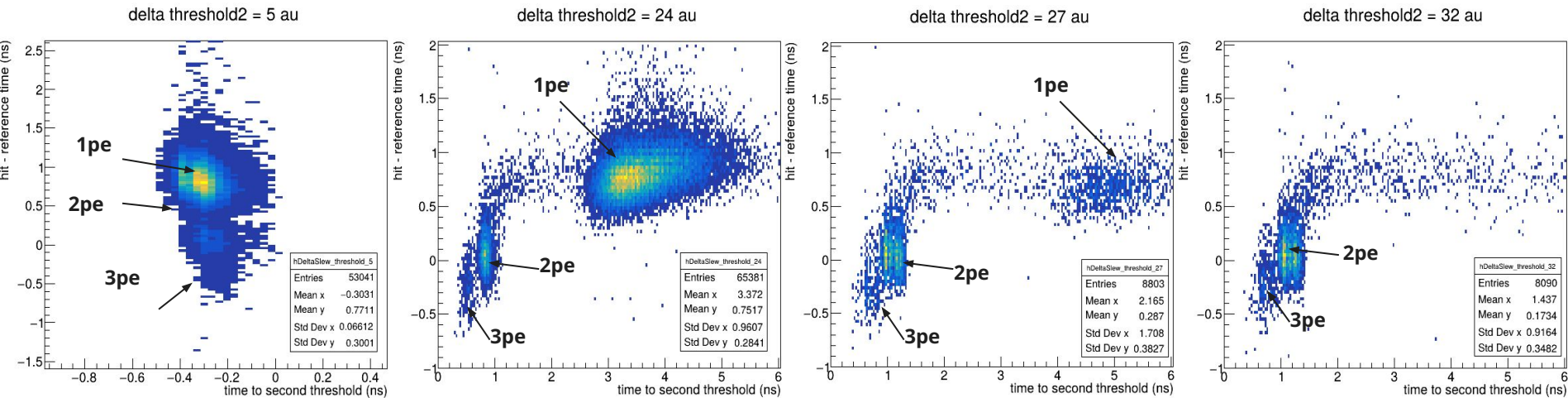

- **Fixed first threshold**
- Only **second threshold is varied** to get delta threshold2 from 5 au to 35 au.
- **delta threshold2 = (Threshold2 - Threshold1)**

Threshold scan in Slew Rate mode

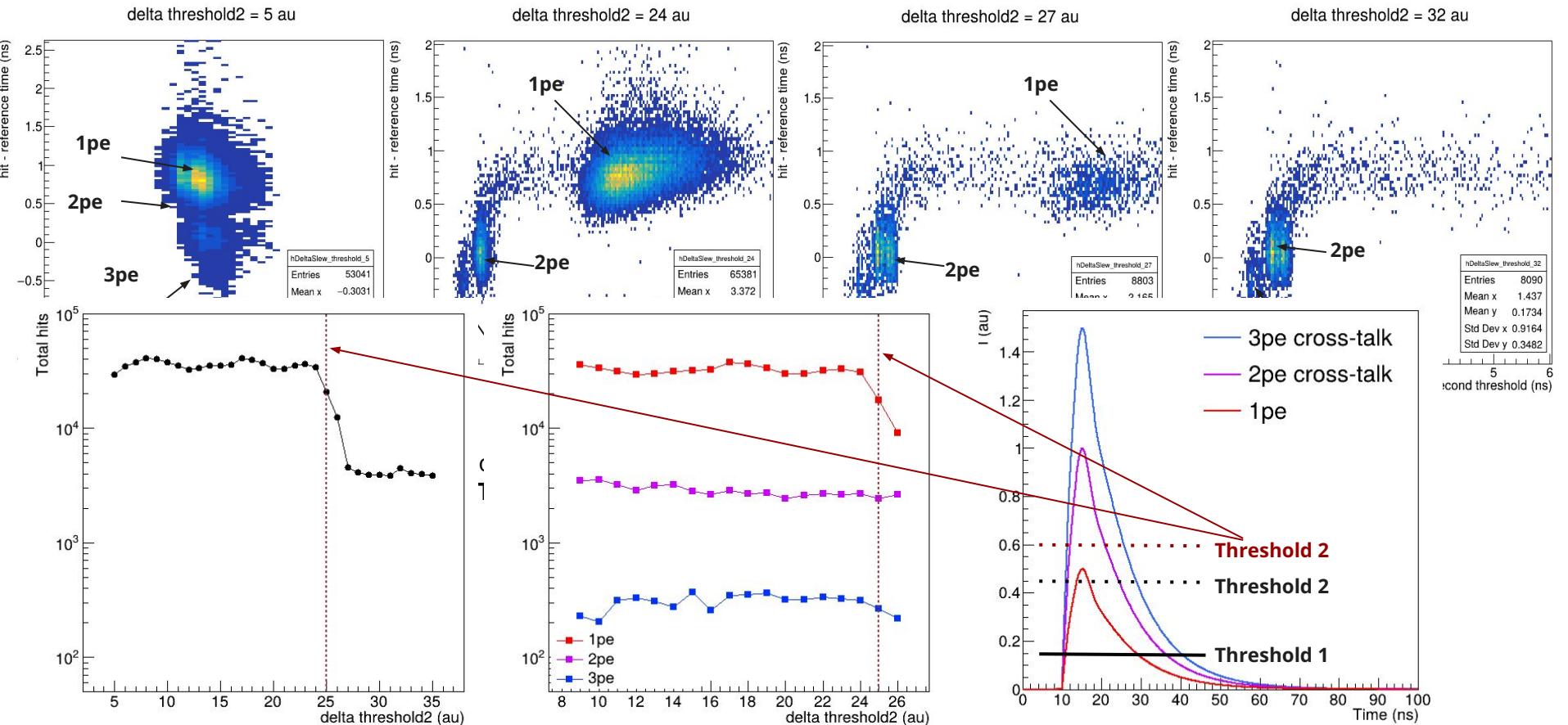

Time walk correction

Methodology:

- **Extract Mean Time:** For each bin along the X-axis (time to second threshold), calculated the mean Y (ΔT) using a weighted average from the histogram.
- **Correct ΔT :** Subtracted the calculated mean ΔT from the original Y value for each bin.
- **Measure σ_t :** Projection was taken on Y axis (ΔT) and fitted with gaussian with exponential tail to measure the time resolution.

Correction for the data at delta threshold2 = 23 au

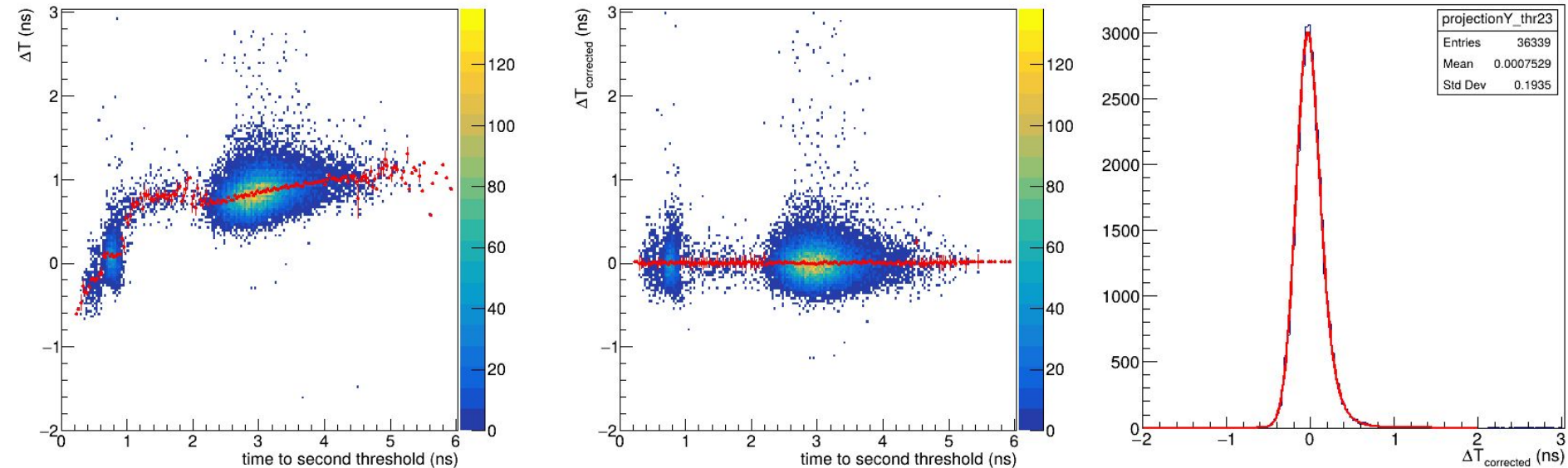

Results after time walk correction

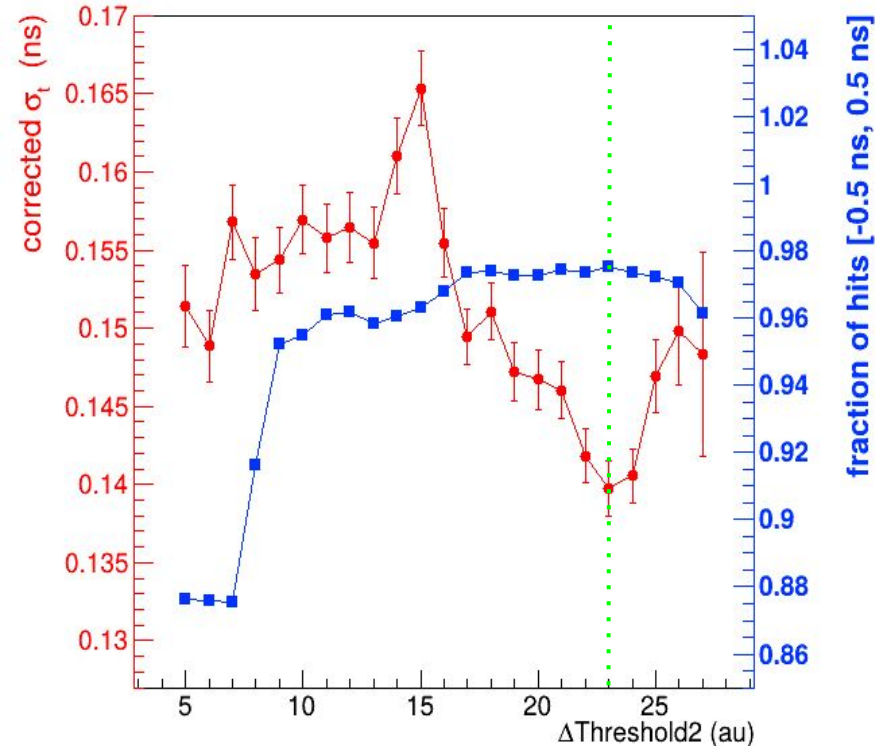

- Also, fraction of the hits which are within the time window of -0.5 ns to 0.5 ns were calculated and plotted against different delta threshold2. (**estimation of efficiency**)
- After delta threshold2 = 15 au, as we increase it, the time resolution is increased (**upto 140 ps**) until we starts skewing the 1pe photopeaks.

Results after time walk correction

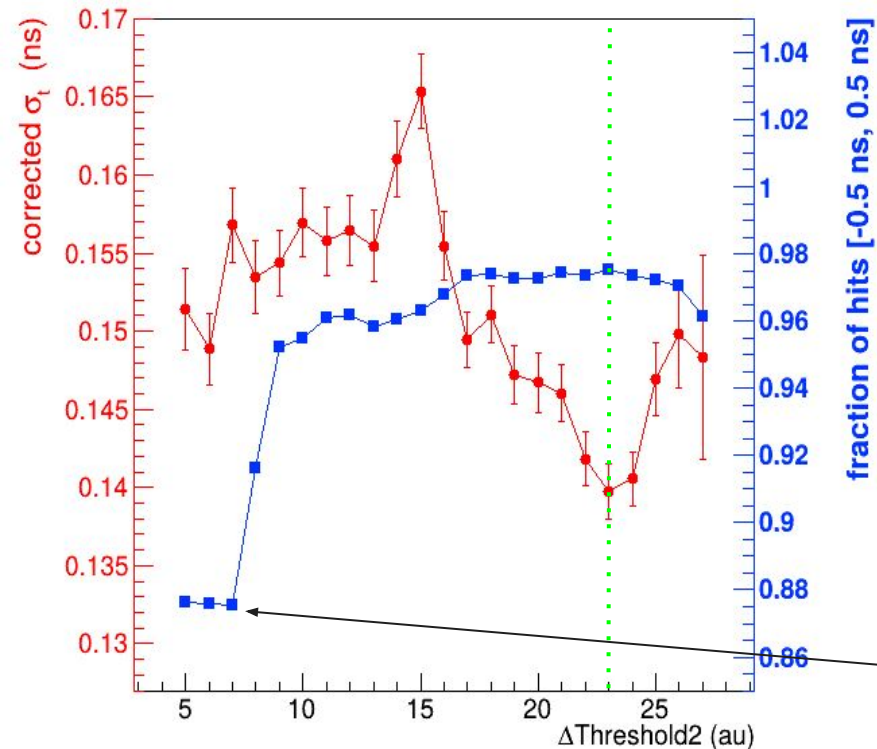

- Also, fraction of the hits which are within the time window of -0.5 ns to 0.5 ns were calculated and plotted against different delta threshold2. (**estimation of efficiency**)
- After delta threshold2 = 15 au, as we increase it, the time resolution is increased (**upto 140 ps**) until we starts skewing the 1pe photopeaks.
- At lower threshold2, the correction did not applied for the 2pe and 3pe signals.

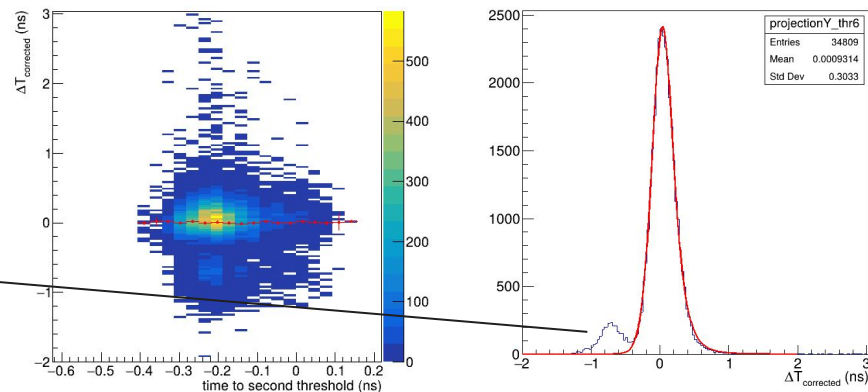

Conclusion and outlook

- SiPM signals are obtained with slew rate mode of ALCOR with **clear identification of 1pe, 2pe and 3pe.**
- SR mode helped to eliminated the issue of afterpulse which was there in ToT mode.
- Second threshold should be lower than the amplitude of 1pe signals.
- Time walk correction has been applied and found that **140 ps resolution** can be achieved, which fullfills the requirements of dRICH detector.
- Upcoming plan is to implement the Time-over-Threshold2 (ToT2) mode of ALCOR and study on it!

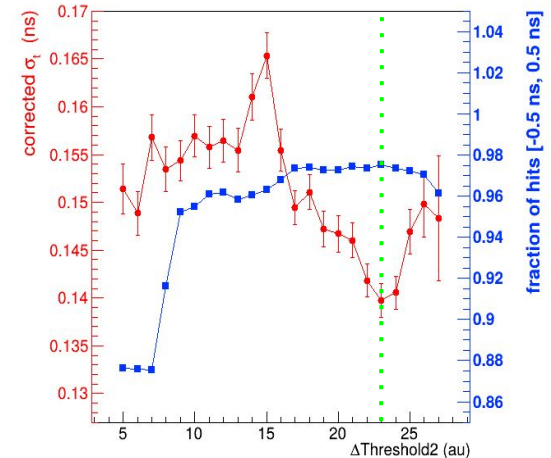
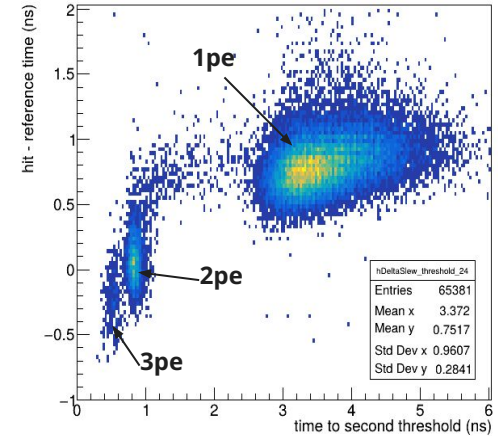

Thank you!

Backup slides...

Time walk correction

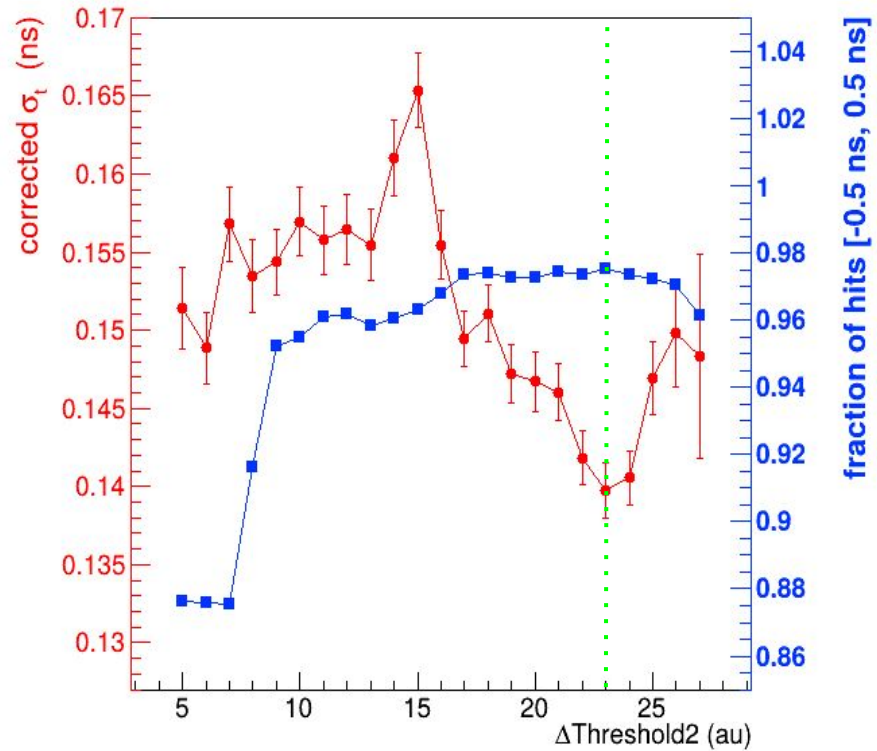
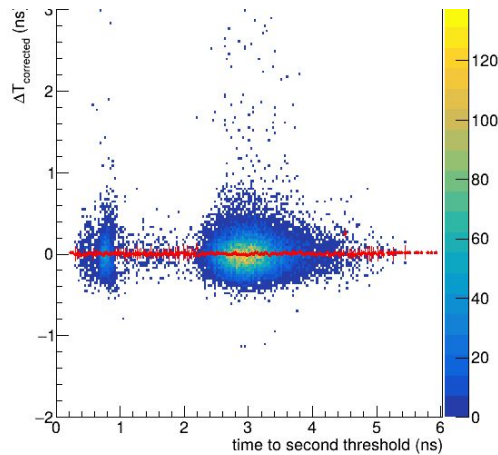
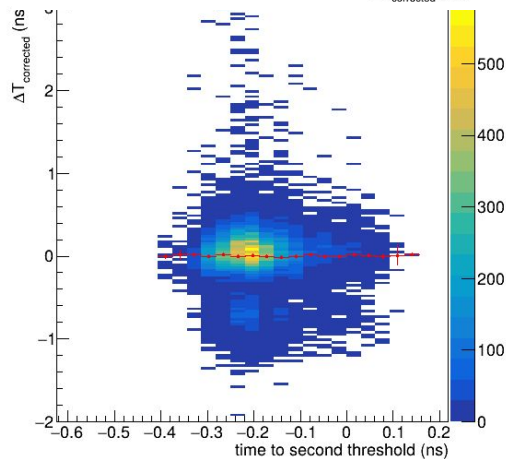
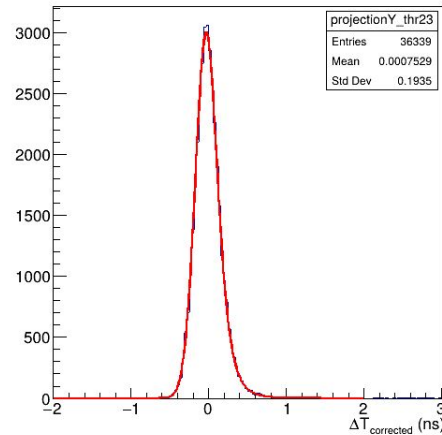
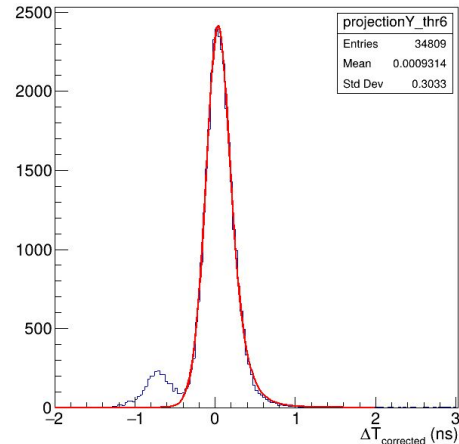

Output waveform of SiPM

Key things to take away:

- Signal shape is similar for all types of waveform.
- The order of pulse **amplitude: after pulse = 1pe < 2pe < 3pe.**
- **Rising time** to certain point is in the order: **3pe < 2pe < 1pe = afterpulse.**
- **Time of Arrival (ToA) of signal** is earlier for **3pe < 2pe < 1pe < afterpulse (because of fast rising time)**

This creates a shift in signal timing for signal with different amplitudes.

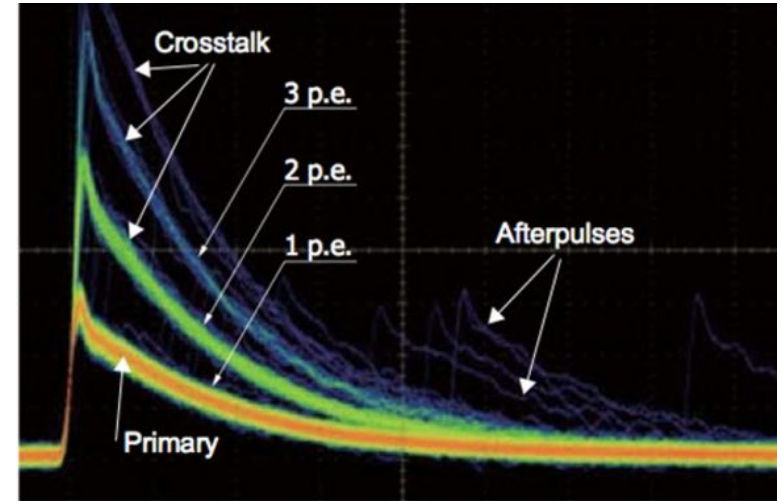
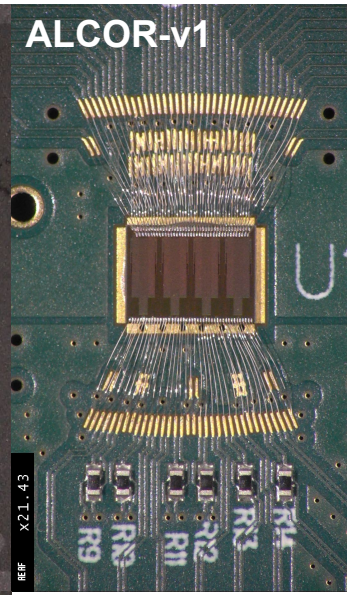
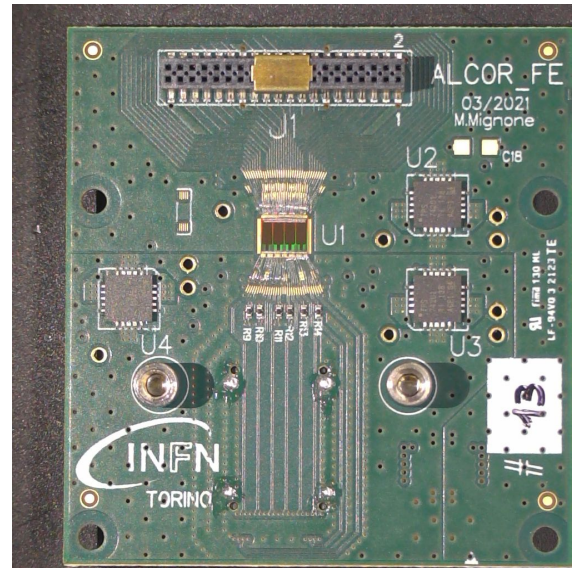
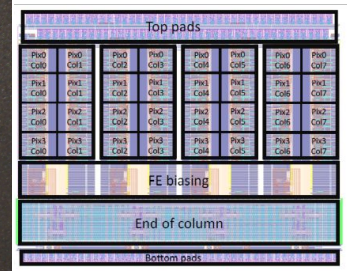

Fig: Oscilloscope trace with the display set to persistence mode (source: HAMAMATSU)

ALCOR ASIC: integrated front-end and TDC



REF X2.1.43



developed by INFN-TO

64-pixel matrix mixed-signal ASIC
 current versions (v1,v2,v2.1) have 32 channels, wirebonded
 final version will have 64 channels, BGA package, 394.08 MHz clock

- **the chip performs**
 - signal amplification
 - conditioning and event digitisation
- **each pixel features**
 - 2 leading-edge discriminators
 - 4 TDCs based on analogue interpolation
 - 20 or 40 ps LSB (@ 394 MHz)
 - digital shutter to enable TDC digitisation
 - suppress out-of-gate DCR hits
 - 1-2 ns timing window
 - programmable delay, sub ns accuracy
- **single-photon time-tagging mode**
 - continuous readout
 - also with Time-Over-Threshold
- **fully digital output**
 - 8 LVDS TX data links

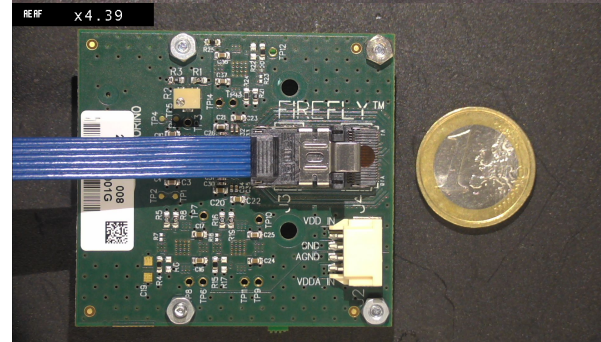

ALCOR Schematic

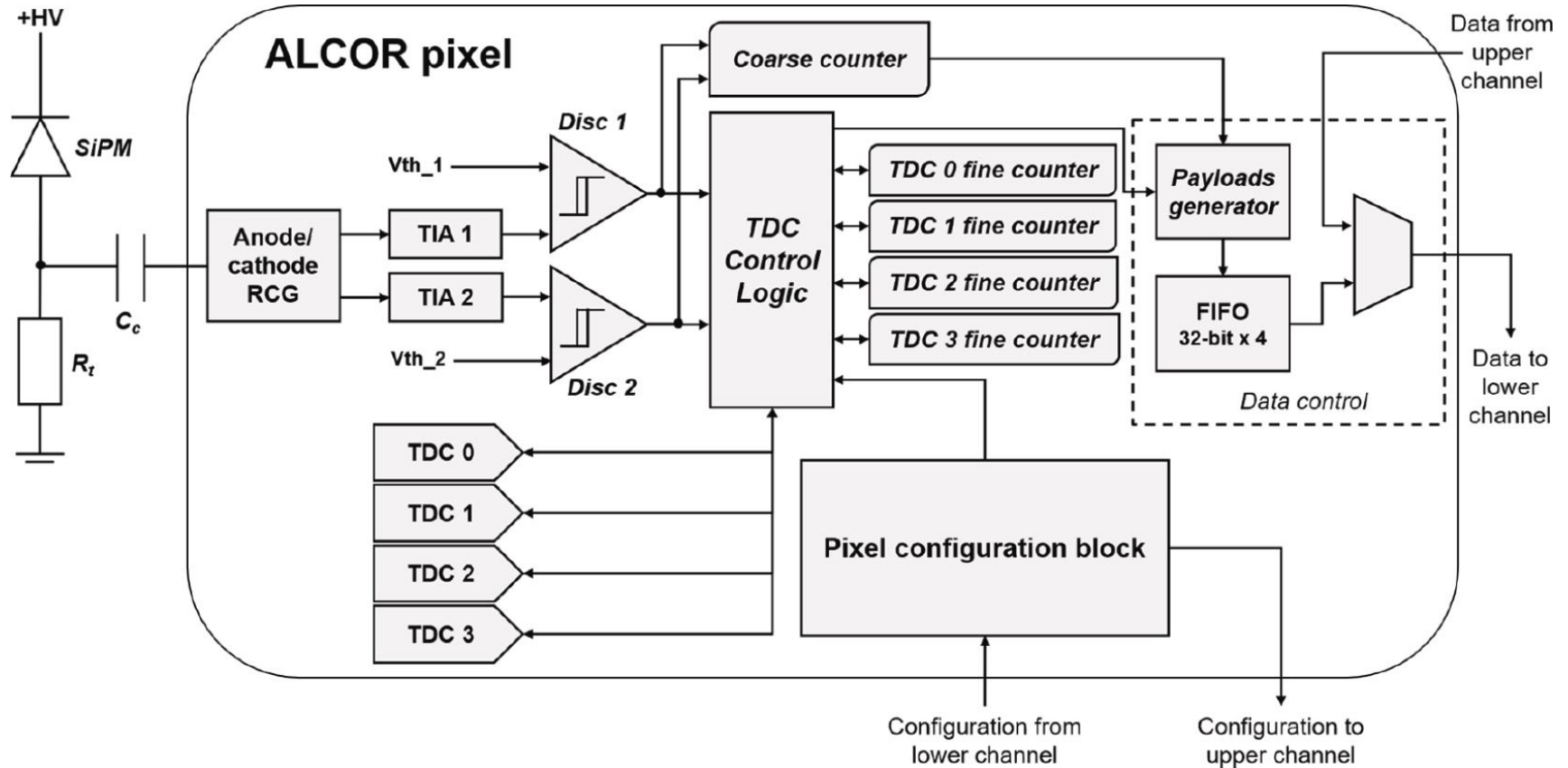

Modes of operation of ALCOR

- **ToA/LET (Leading edge trigger):** the rising edge of the first discriminator is recorded, thus providing only the event ToA (Time of Arrival)

To resolve this effect there are different modes of operations in ALCOR chip.

- **ToT (Time over threshold):** both rising and falling edges of the first discriminator are captured, producing also the ToT measurement from which a proxy of the input signal charge can be extracted.
- **TOT2:** provides the same information as ToT mode but in this case the falling edge is captured by the second discriminator.
- **SR (Slew rate):** both the discriminators provides time stamps on the rising edge of the signal at different thresholds .

We can use the information from second discriminator of ALCOR chip and use ToT2 or SR mode to correct for the time walk.

Photopeak identification for SR mode

Signals with **higher slope** in the rising edge are **earlier** so they have **smaller hit-reference time (ΔT)** and they also take less time to reach to the second threshold, therefore **smaller time to second threshold (TST)**.

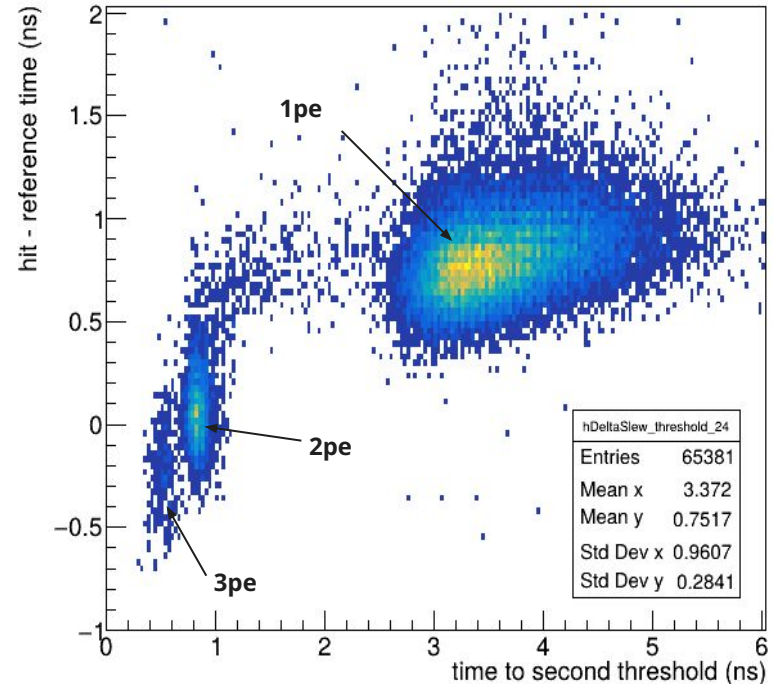
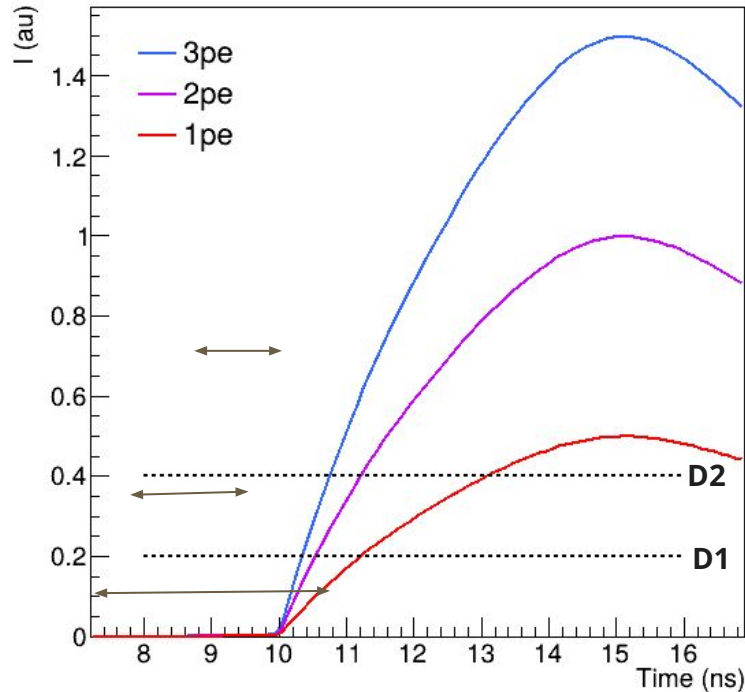

Graphical cuts applied to separate different photopeaks

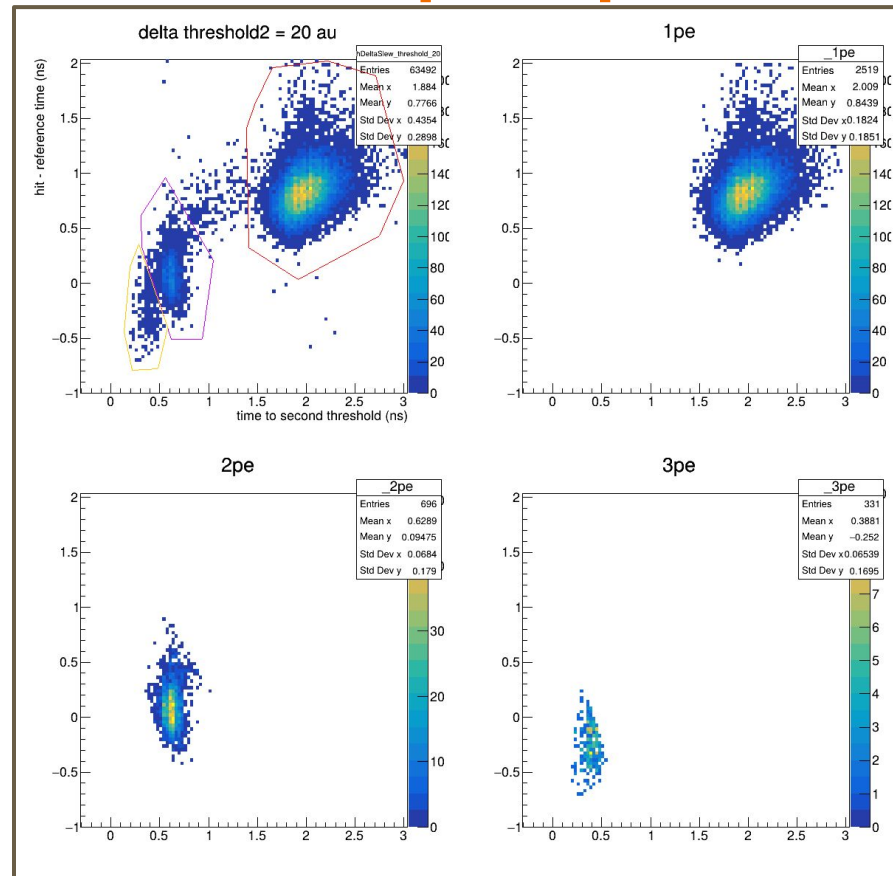
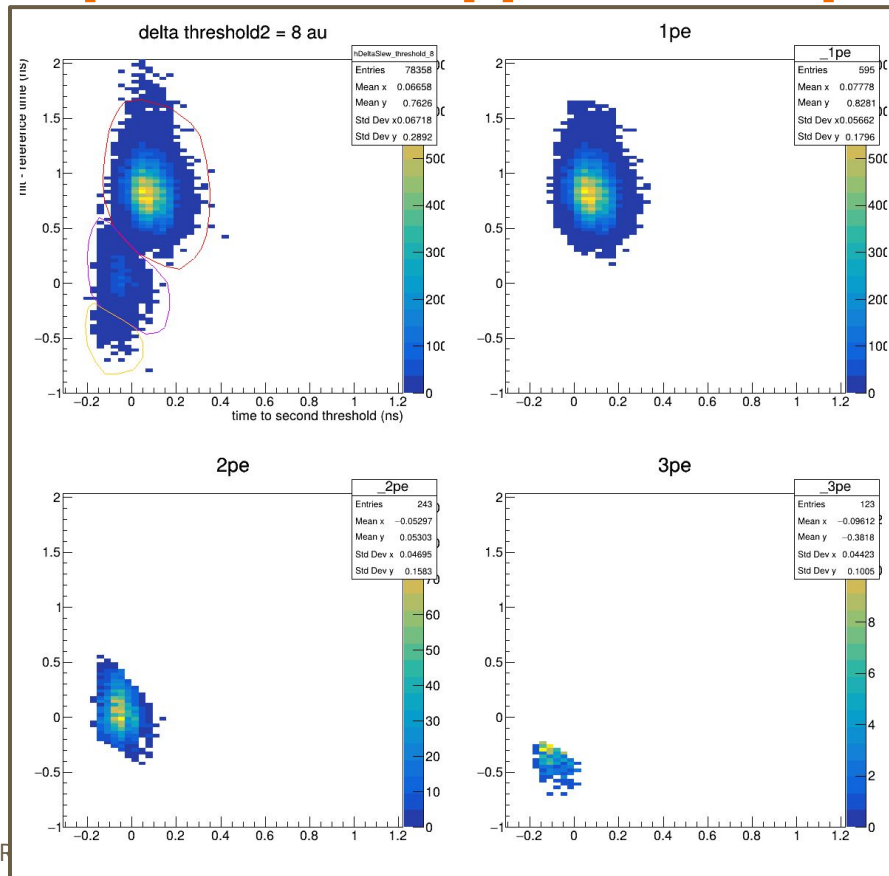

Change in total number of hits

The total number of hits starts decreasing when the second threshold is higher than the amplitude of the 1pe signal.

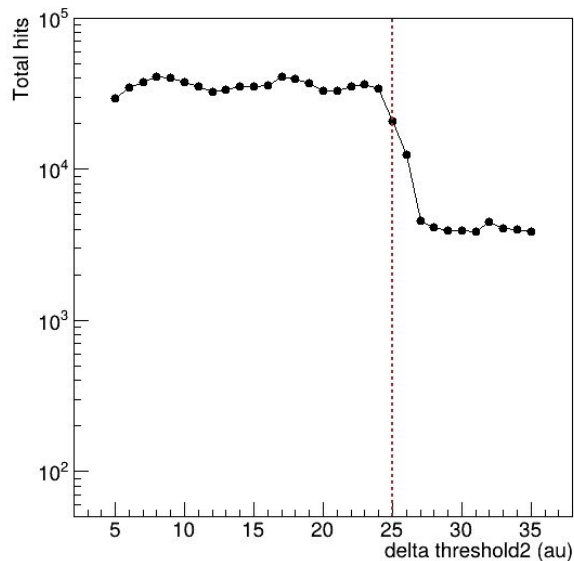

After cut: Total hits contribute to each photopeaks vs delta threshold2

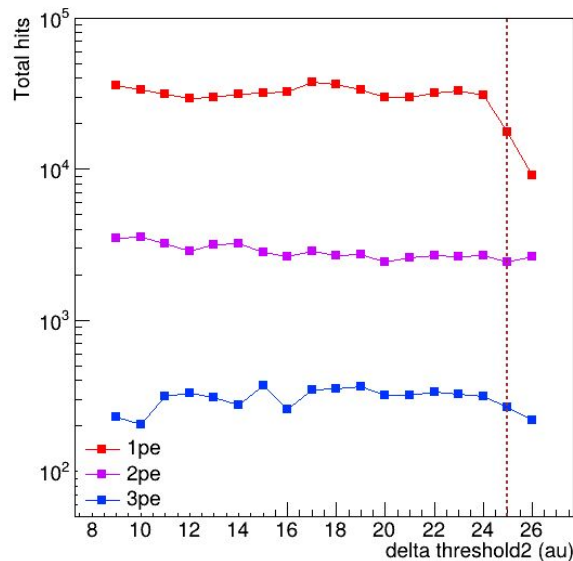

A sample SiPM Pulse, displays the 1pe pulse missing after certain threshold.

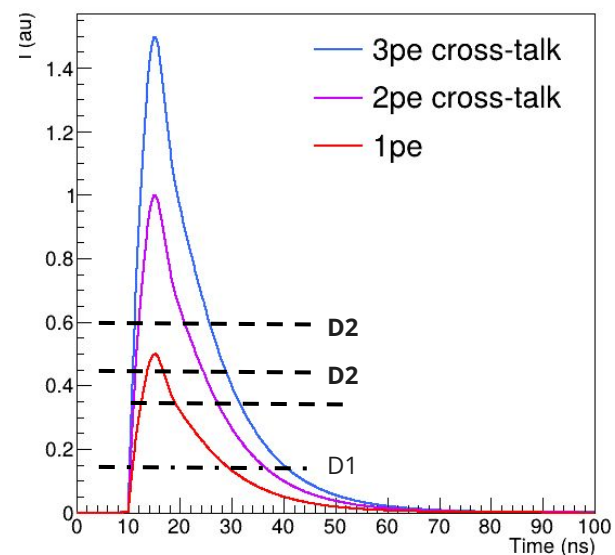

Projection along y-axis:

Considering only the information of time of arrival of the signal.

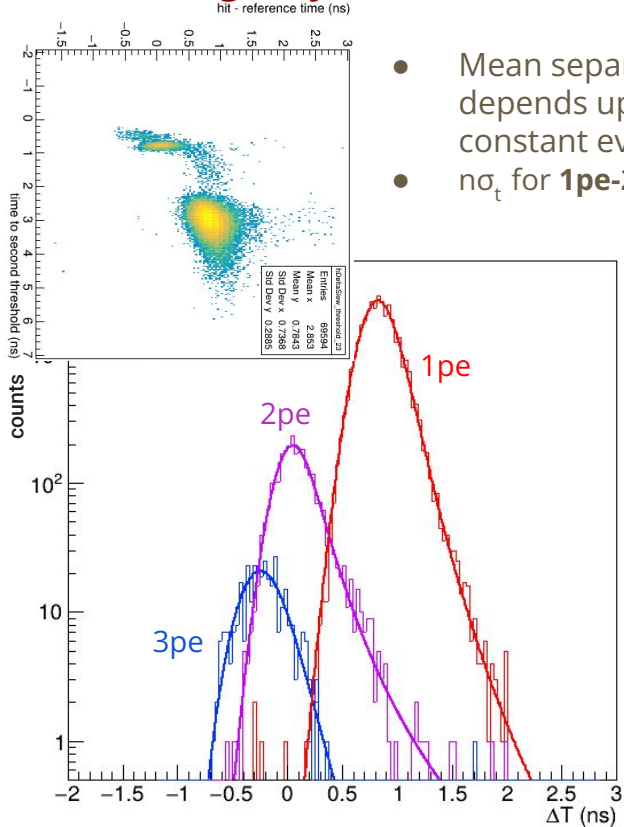

- Mean separation is the time separation between the peaks. In this case, mean of a peak depends upon the Time of arrival of the signal, therefore mean of each peak remains almost constant even if we change the second threshold.
- $n\sigma_t$ for **1pe-2pe** is greater the **3σ** , in almost all cases.

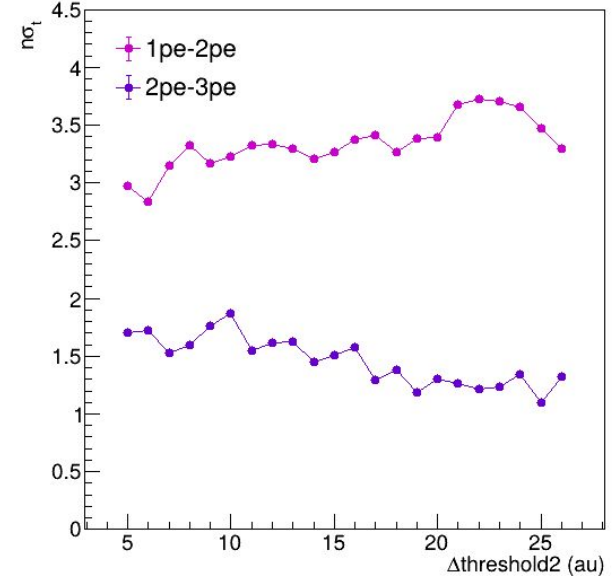
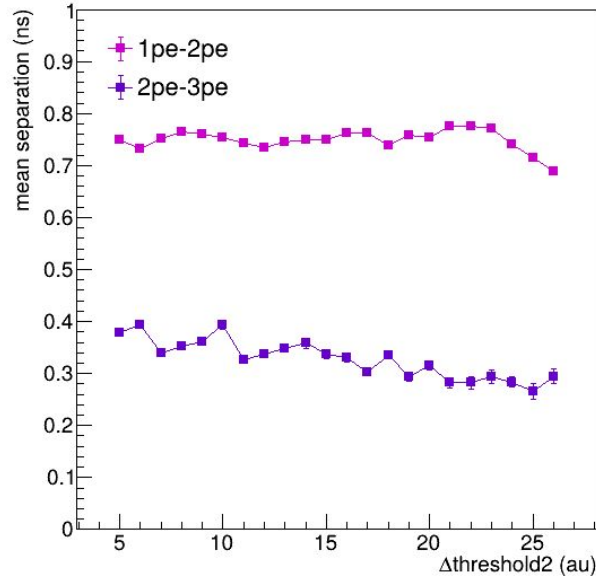

[doi:10.1088/1748-0221/11/10/P10016](https://doi.org/10.1088/1748-0221/11/10/P10016)

B Rajesh Achari | brajesh.achari@unibo.it

Projection along x-axis:

Considering only the information of time it takes to reach to the second threshold.

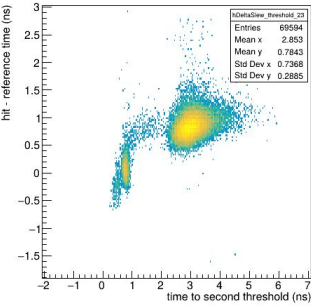

- At lower delta threshold, peaks are not clearly resolved but at higher 1pe can be clearly resolved from the other peaks.
- $n\sigma_s$ also increases as we increase the delta threshold but after certain point it goes down as the 1pe get skewed and results in high.

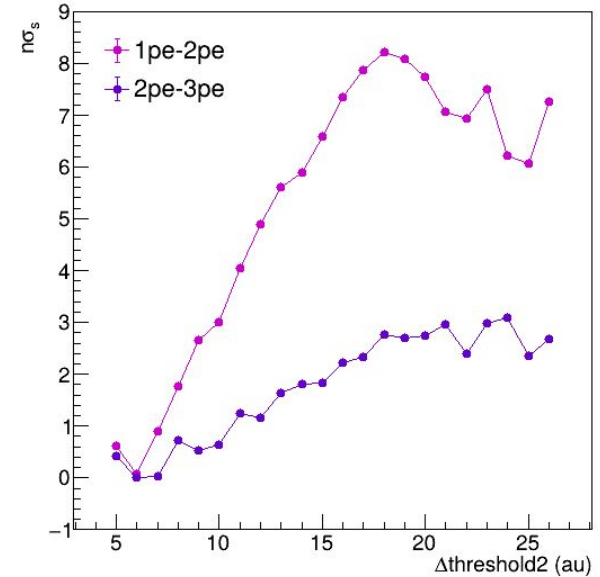
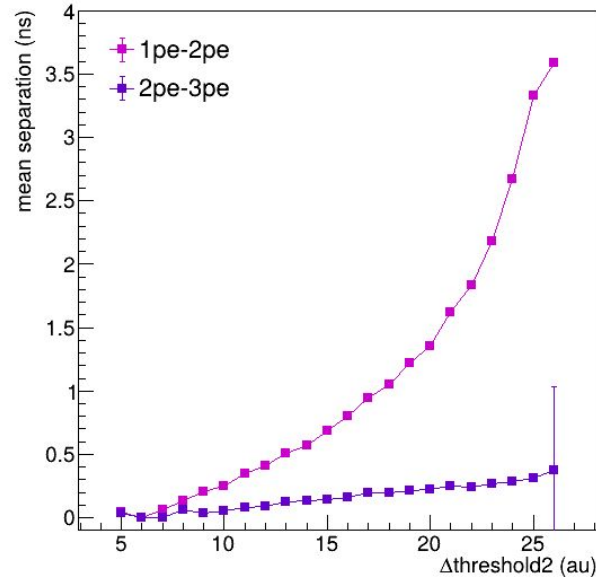
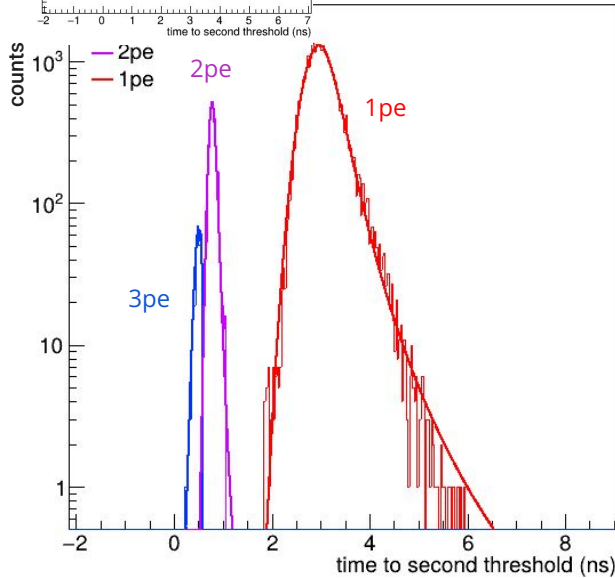

Time correction for the signal at delta threshold2 = 6 au

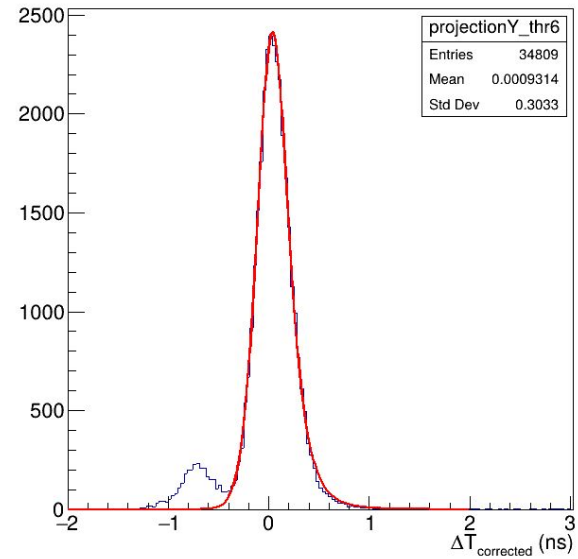
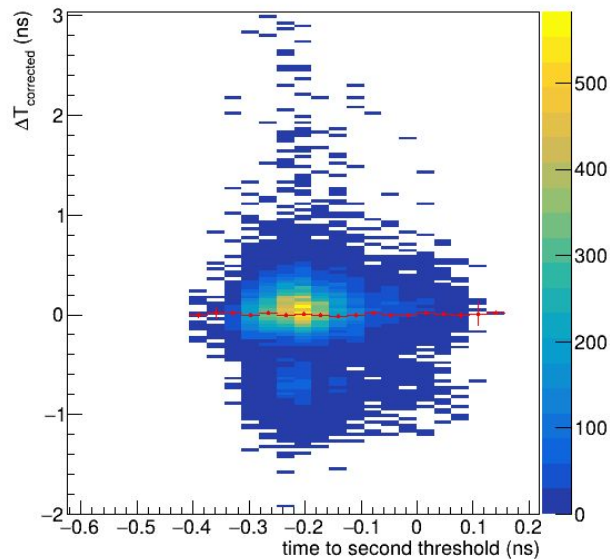
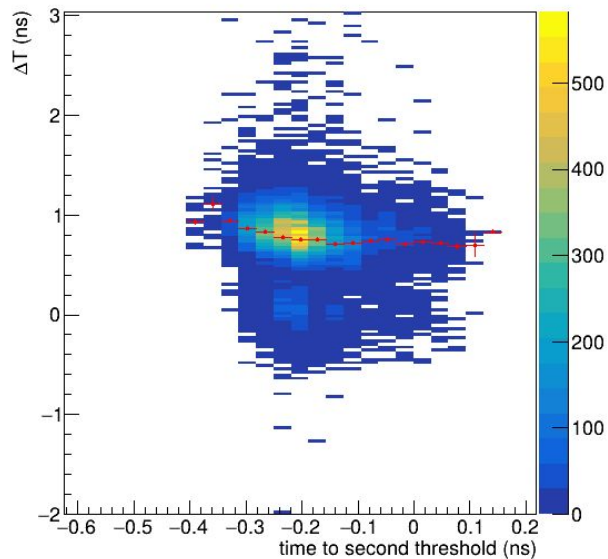

Slew-rate mode

In this mode both the discriminators record the time stamp on the rising edge of the signal.

The data has been taken at a common first threshold which was set at 5 au, and the second threshold was varied from 5 to 35 au (delta threshold2) w.r.t the first threshold.

Observations after a first glance:

- There is some shifts in peaks .
- After certain delta threshold2, we are missing one peak.

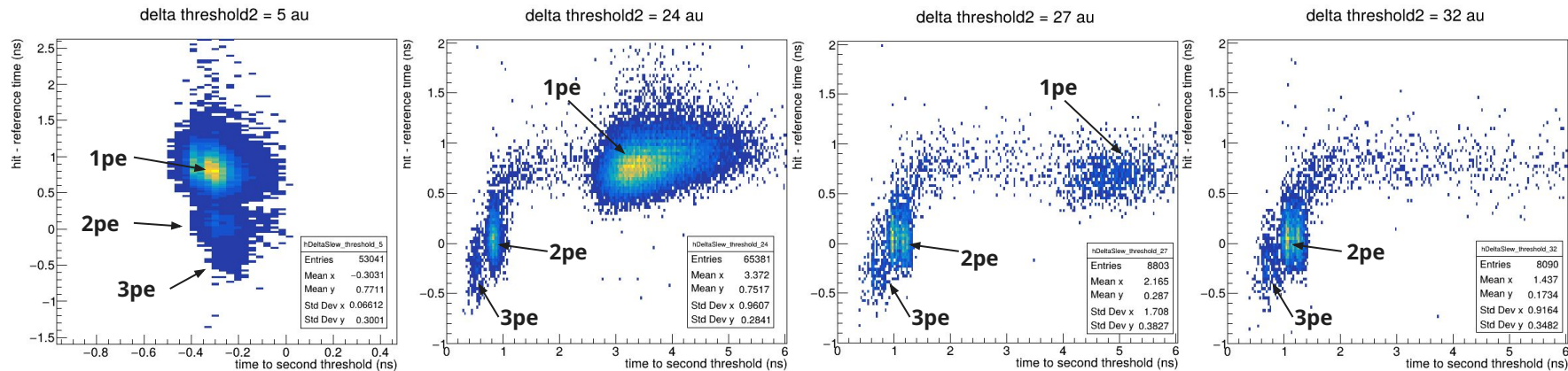

Time walk correction

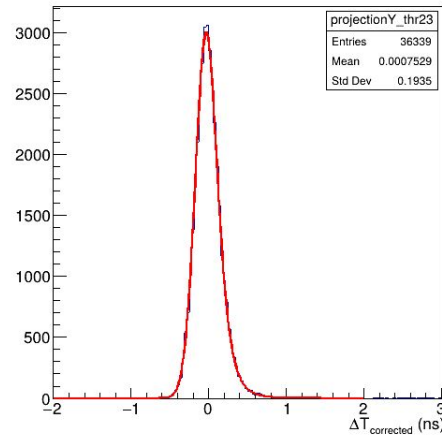
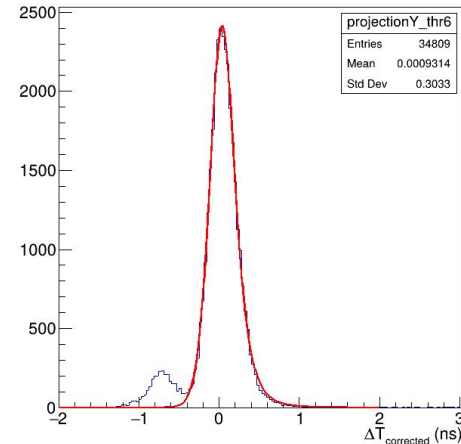

Only considered the data in which 1pe information is there.

Correction Methodology:

1. **Extract Mean Time:** For each bin along the X-axis (time to second threshold), calculated the mean Y (ΔT) using a weighted average from the histogram.
2. **Correct ΔT :** Subtracted the calculated mean ΔT from the original Y value for each bin.
3. **Measure σ_t :** Projection was taken on Y axis (hit - reference) and fitted with gaussian with exponential tail to measure the time resolution.

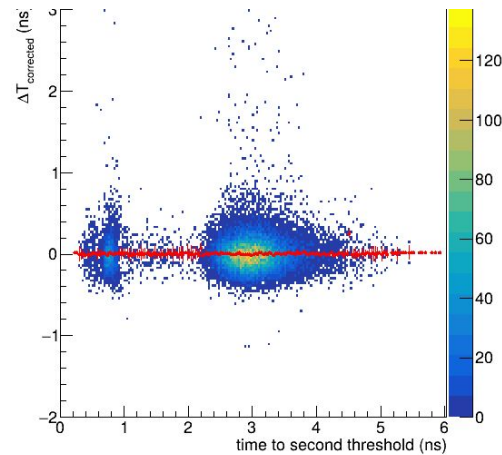
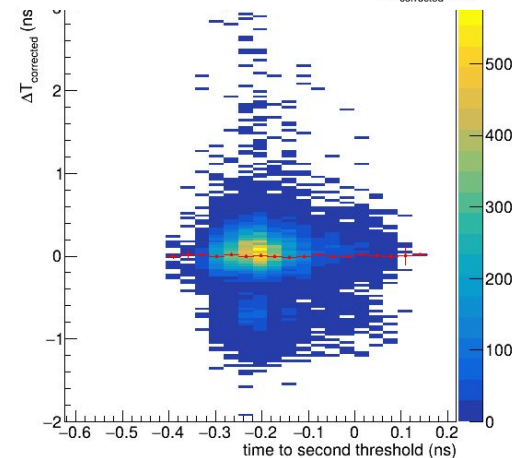

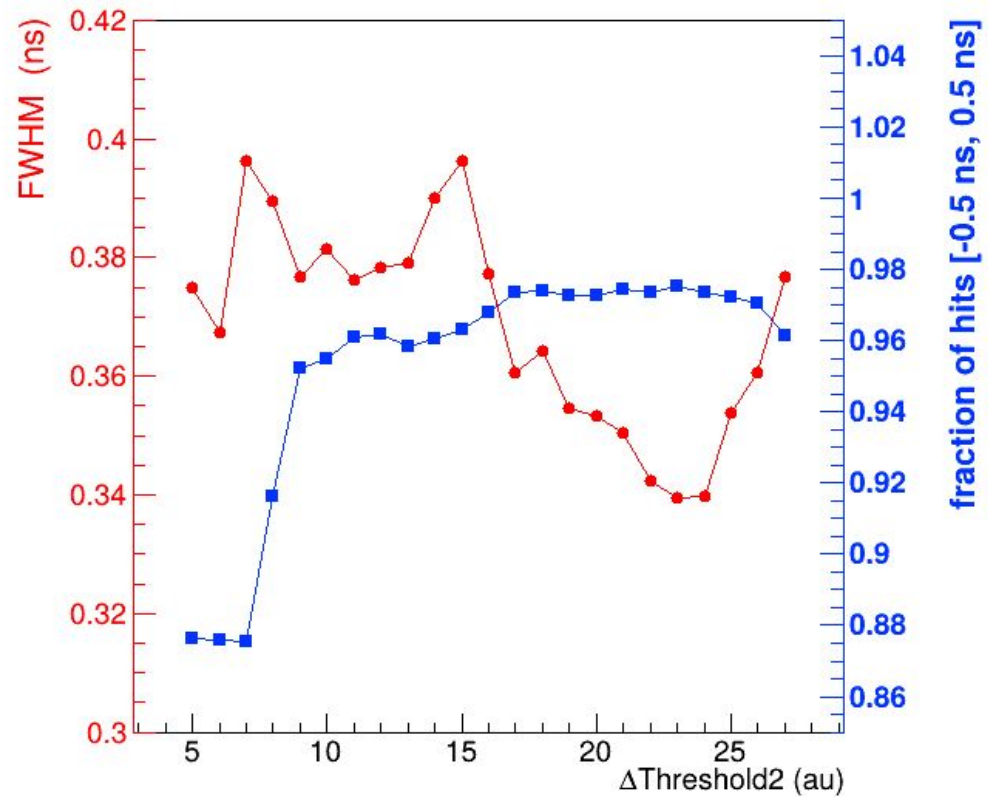

Experimental Setup for Timing Measurements

