

MUON COLLIDER activities in 2024 and 2025 and related requests to CSN1 for 2025

Dario Giove

Muons are one of the most [basic building blocks of the Universe](#), but they have never been used in a particle collider. A muon collider could be a possible post-[High Luminosity LHC](#) machine, to explore high-energy physics frontiers with a relatively small environmental footprint.

- A circular particle accelerator steers beams of charged particles into a curved path to travel around the accelerator's ring. As they curve, the particles lose energy by emitting what's known as synchrotron radiation. The more massive a particle, the less energy it loses through synchrotron radiation. Being 200 times heavier than electrons, muons emit about two billion times less synchrotron radiation. Muons are fundamental particles, unlike the LHC's protons, which are made up of quarks. A muon collider could therefore run using less energy, for example a 10 TeV muon collider could be competitive with a 100 TeV proton collider.

- The idea of a muon collider is not new - it was first introduced 50 years ago - but a major technical challenge results from the muon's short lifetime. When at rest, it decays after only 2.2 microseconds into an electron and two kinds of neutrinos, however its lifetime increases with energy. Dealing with this short lifetime requires developing innovative concepts and demanding technologies.

- Studies submitted to the 2020 update of the [European Strategy for Particle Physics](#) showed that a muon collider in the multi-TeV energy range would be promising both as a precision and as a discovery machine. The [strategy update](#) recommended to integrate an international design study for a muon collider into the European Roadmap for accelerator R&D.

- As a result, the [International Muon Collider Collaboration](#) is conducting a detailed feasibility study to confirm the realistic performance and feasibility of such a machine, identifying the required R&D to address its specific challenges, especially the compatibility of existing facilities with muon decays.

Muon Collider Magnet team

Fusion like - designed by F4E
20 T -1MW on target

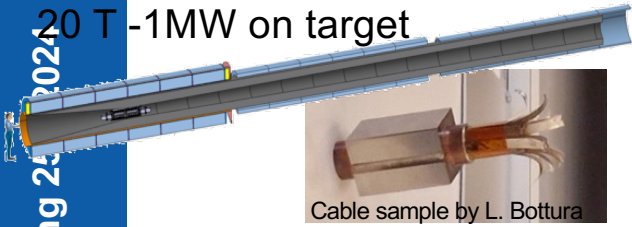

2 km
Field up to 20 T
½ m bore
About 1500

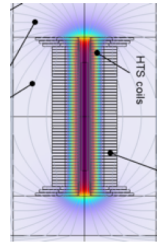
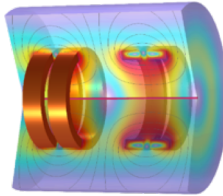

40 T
Small

Newcomer
10 T dipole for
accel

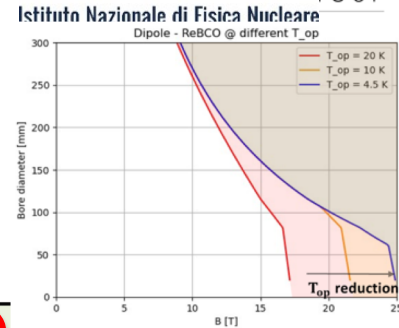
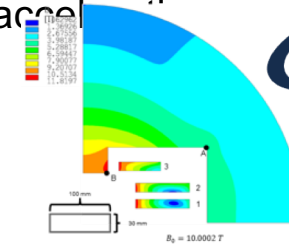

The SC magnets are coordinated by INFN

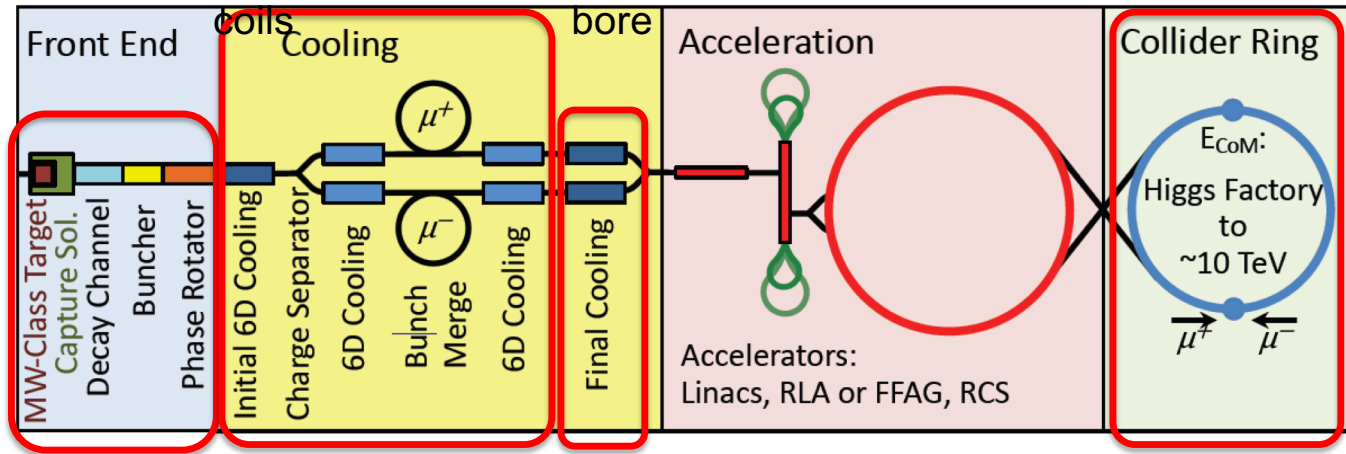

Dipoles
15T / 140 mm
Quadrupoles
G 300 T/m
120 mm
Nb3Sn and HTS
Producing parameters maps

Shared R&D on conductor properties

Task 7.2



Task 7.3

Task 7.4



Muon collider and RF system challenges

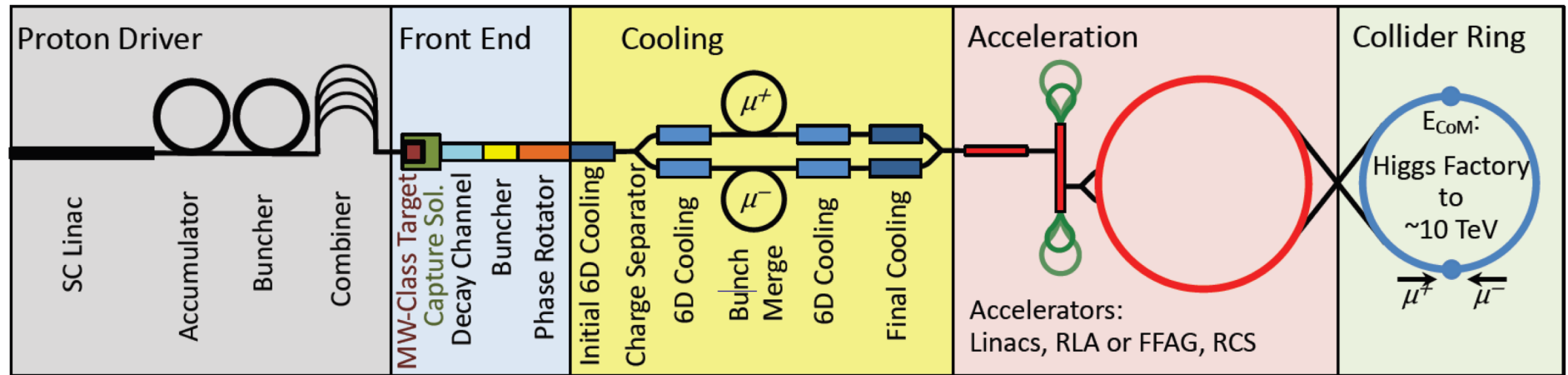

The main responsibilities covered by INFN in the project are related to the magnets and RF cavities (normal conducting) for the cooling channel; SC magnets (see previous slide); contribution to SC RF cavities for the accelerator section.

Normal conducting RF for capture and cooling

- **High-gradient cavities in high magnetic field**
- High charge, Huge beam size, Important beam losses
- Peak RF power

RF Cavity and RF Structure Design



A decision on the type of RF structure that will have to be integrated in the cell requires taking into account a number of parameters that may be summarized as in the following:

- the RF frequency
- the required real estate gradient of the electric field in a cell vs. the peak gradient achievable in the RF structure
- expected breakdown rate and eventual mitigation strategy, especially in the high magnetic field and high magnetic gradient they experience
- specific materials and surface treatments for the cavity bodies.
- the type of RF coupling from cell to cell in a RF structure
- the space available to fit ancillaries (e.g. tuners, power couplers, cooling pipes etc...), considering the tight interference with the cryomagnetic system
- the available or realistically feasible power sources

Most of the parameters being used for simulations of the entire cooling section are at the edge or beyond the present state-of-the-art, therefore require careful evaluation of the feasibility of the corresponding technological solution.

E-field in High Magnetic Gradients



Set-up at LASA

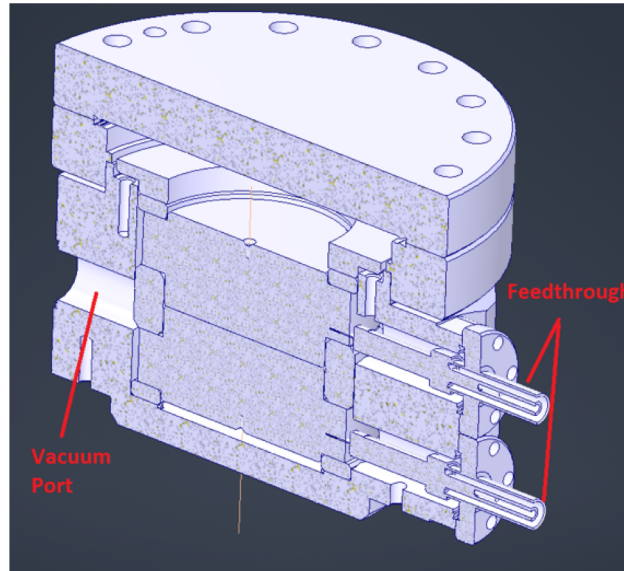

The PVX-4110 pulse generator is a direct coupled, air cooled, solid state half-bridge (totem pole) design, offering equally fast pulse rise and fall times, low power dissipation, and virtually no over-shoot, undershoot or ringing. It has overcurrent detection and shutdown circuitry to protect the pulse generator from potential damage due to arcs and shorts in the load or interconnect cable.

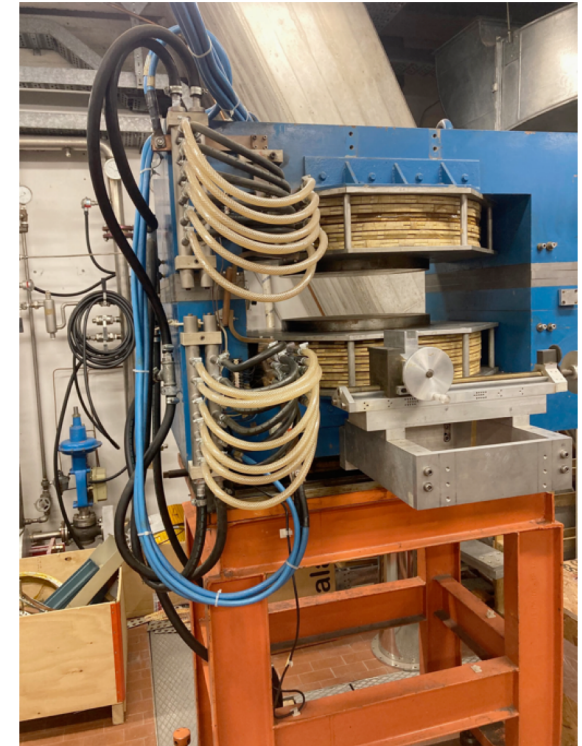

Suitable to test different materials, surface finishing and treatments up to 50 MV/m

E-field in High Magnetic Gradients

Requests for 2025

Vacuum desiccator for proper storage of materials treated for HV tests



• Download: Vakuu Exikka

Capacity [Liters]	Excess length of valves and vacuum gauge [mm]	Maximum all-over load [kg]	Overall dimensions [W x H x D mm]	Total all-over load [kg]	Usable interior space [W x H x D mm]	Weight [kg approx.]	Unit price	Product number
18	100	30	300 x 340 x 300	9	260 x 260 x 260	15	€5,469.33*	V1880-04 A
25	100	40	300 x 440 x 300	9	260 x 360 x 260	18	€6,119.05*	V1880-08 B
32	100	50	315 x 550 x 310	9	265 x 460 x 260	27	€7,442.74*	V1880-12 C

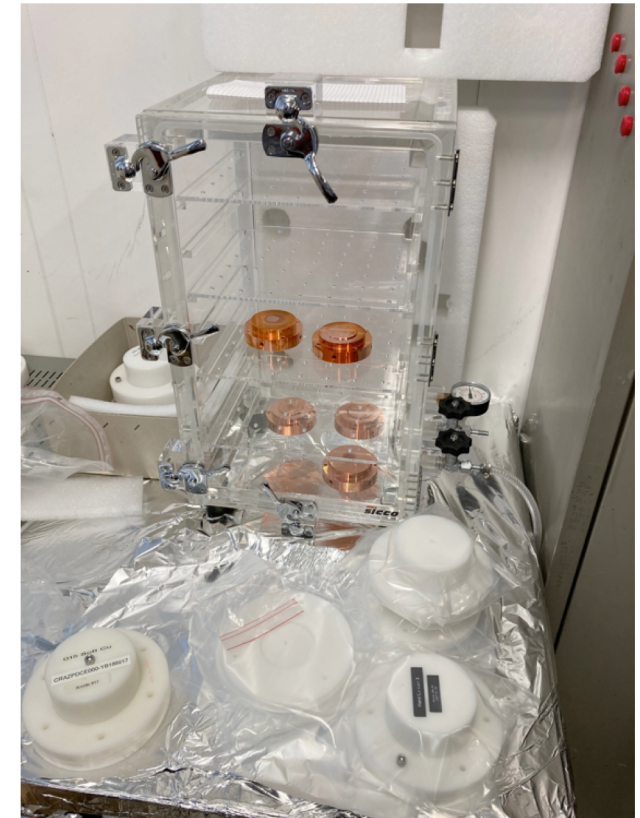

Consumables for the laboratory tests (surface treatments, etc.)

10 kEuro + 5 kEuro

RF cell @704 MHz and 3 cells RF preliminary structure

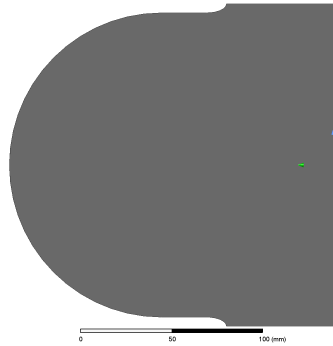

Analysis

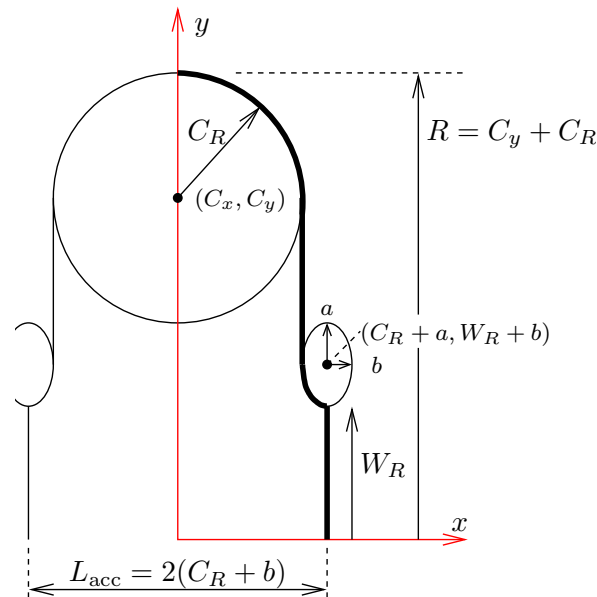

Geometric parameters for $L_{acc} = 180$ mm

param.	value (mm)
R_c	85
R_i	60
R_v	181.35
a	5
b	11

Table 5: $E_{in} = 37.8$ J

Descrp.	Param.	Unit	INFN
Transit Time	T		0.67
Aver. Nom. gradient	E_0	MV/m	43.9
Accelerating gradient	E_{acc}	MV/m	29.4
Quality Factor (eig.)	Q		40600
Effect. Shunt Impedance	R	MΩ	6.81
Effective R over Q	R/Q	Ω	167.66
Dissipated power	P_{diss}	MW	4.12

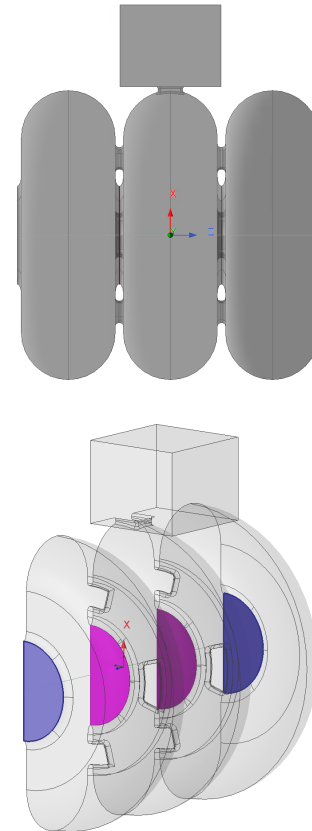

RF cell @704 MHz and 3 cells RF preliminary structure

Requests for 2025

RF cables and adapters for laboratory measurements

External draftman for the design of specific pieces

8 kEuro + 5 kEuro

REBCO Tape related activities



A 5 km RebcO Tape sample has been ordered in November 2023 to perform tests on the material and the capability to handle it at LASA.

Unfortunately the order was available only in late march 2024.

At the same thanks tests carried out at CERN on the same material from the same supplier result in dimensional non conformities. The supplier had the time to face the problem and perform a repair action. The delivery at LASA of the materials is foreseen for the end of July 2024.

Activities foreseen in 2025



Refine the study for a single 704 MHz and 1 GHz cavity
Build a prototype

Design a complete 3 cells model useful for the demonstrator tests of the Muon Collider
Design the magnets for the cooling cell prototype and define integration process

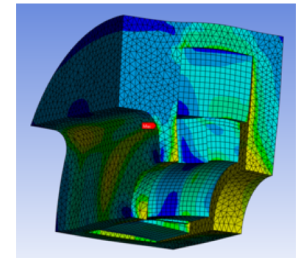

Build a prototype for the main elements of the cooling cell for the demonstrator

Put and maintain in operation the pulsed DC test and perform extensive analysis of the behavior of copper and aluminum electrodes after different surface treatments.

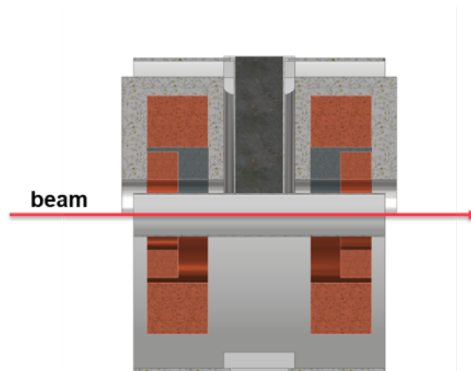

Main challenges

- Force management (30 MN range)
- Access for waveguide
- Conduction cooling

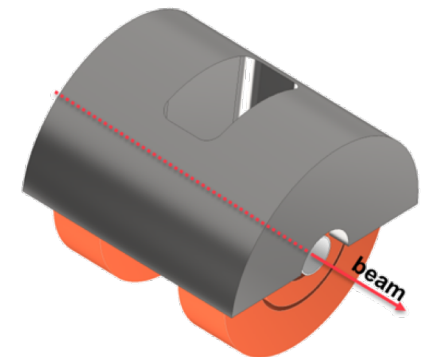

Activities foreseen in 2025

The design of a **full cell prototype** is a more than relevant step in the evolution of the Muon Collider. Up to now we have defined the general requirements coming from the different components that have to work in a synergic way within the structure: SC solenoids, 3 cells RF structure along with RF power feeder and related auxiliary resources, absorbers, ...)

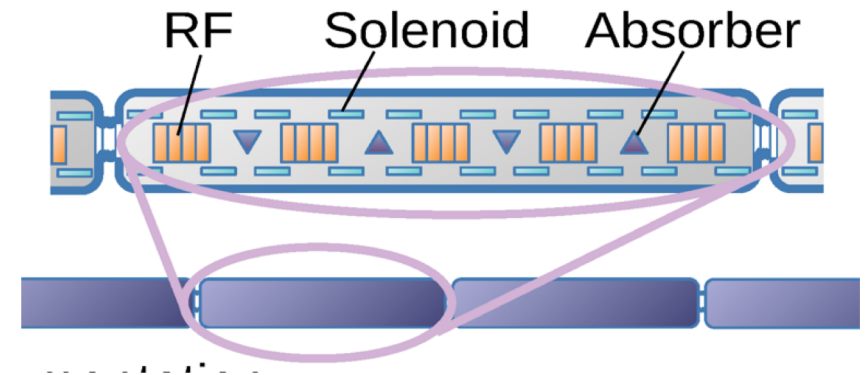

Since one month we are going to provide the first engineering design of the structure facing the space integration issues.

We are planning to end this work (which will take advantage from the support of the Turin colleagues) within few month and present a report of the status of the activities.

This report will be submitted to CSN1 to discuss the 150 kEuro (SJ) request to proceed toward a detailed design report (with cavities at 704 MHz and at 1 GHz) for the construction of a prototype cooling cell.