

# Detection of electron showers in Dual-Readout crystal calorimeters



FRONTIER DETECTORS FOR FRONTIER PHYSICS  
La Biodola, Isola d'Elba, Italy, 20-26 May 2012

Michele Cascella, Università del Salento & INFN Lecce  
Silvia Franchino, Università di Pavia & INFN Pavia,  
on behalf of the RD52 collaboration



## Dual Readout Method principle

- The Dual REAdout Method (DREAM) allows to improve the performances of hadronic calorimeters by measuring event-by-event the electromagnetic fraction of the hadronic cascade, thus reducing its fluctuation and obtaining a better resolution and linearity.
- The method is based on the separation of the scintillation light due to ionization from Cherenkov light produced almost exclusively by relativistic particles, i.e. the electromagnetic component of the hadronic shower.
- The DREAM method has been applied to both fiber calorimeters and homogeneous media (crystals).
- We have tested matrices of BGO and PbWO<sub>4</sub> crystals as electromagnetic calorimeters and studied the properties of the Cherenkov (C) and scintillation (S) components of the signals generated by high-energy electrons showering in these detectors.
- In 2011 the DREAM proposal was accepted by CERN as official R&D project: RD52.

## Crystals for Dual Readout technique

Four possible methods to achieve separation of Cherenkov light (C) and Scintillation one (S) in homogeneous media (only the first two used in this analysis)

	Cherenkov	Scintillation
Time structure	Prompt	Exponential decay
Light spectrum	$1/\lambda^2$	Peak
Directionality	Cone: $\cos\theta_C = 1/\beta n$	Isotropic
Polarisation	Polarised	Not polarised

Time structure readout

Optical filters used:

In order to have the best possible separation, a crystal must have a scintillation emission:

- with a decay time of order of tenths of nanoseconds
- in a wavelength region far from the bulk of the C signal

Filter type	Filter name	> 90% transmission for
UG11	"UV"	$\lambda < 400$ nm
U330		$\lambda < 410$ nm
UG5	"Blue"	$\lambda < 460$ nm
GG495	"Yellow"	$\lambda > 495$ nm

Since 2006 the DREAM collaboration studied the feasibility of separation of C and S signals in many different crystals: PbWO<sub>4</sub> (undoped and doped with different concentrations of Mo and Pr), BSO and BGO crystals.

Average time structure of the signals from a single Mo-doped PbWO<sub>4</sub> crystal, placed at an angle of 60° with the beam line. The light produced by the particles traversing this crystal was filtered with UG11 for C light and GG495 filters for S light extraction. The two completely different time structures are visible.

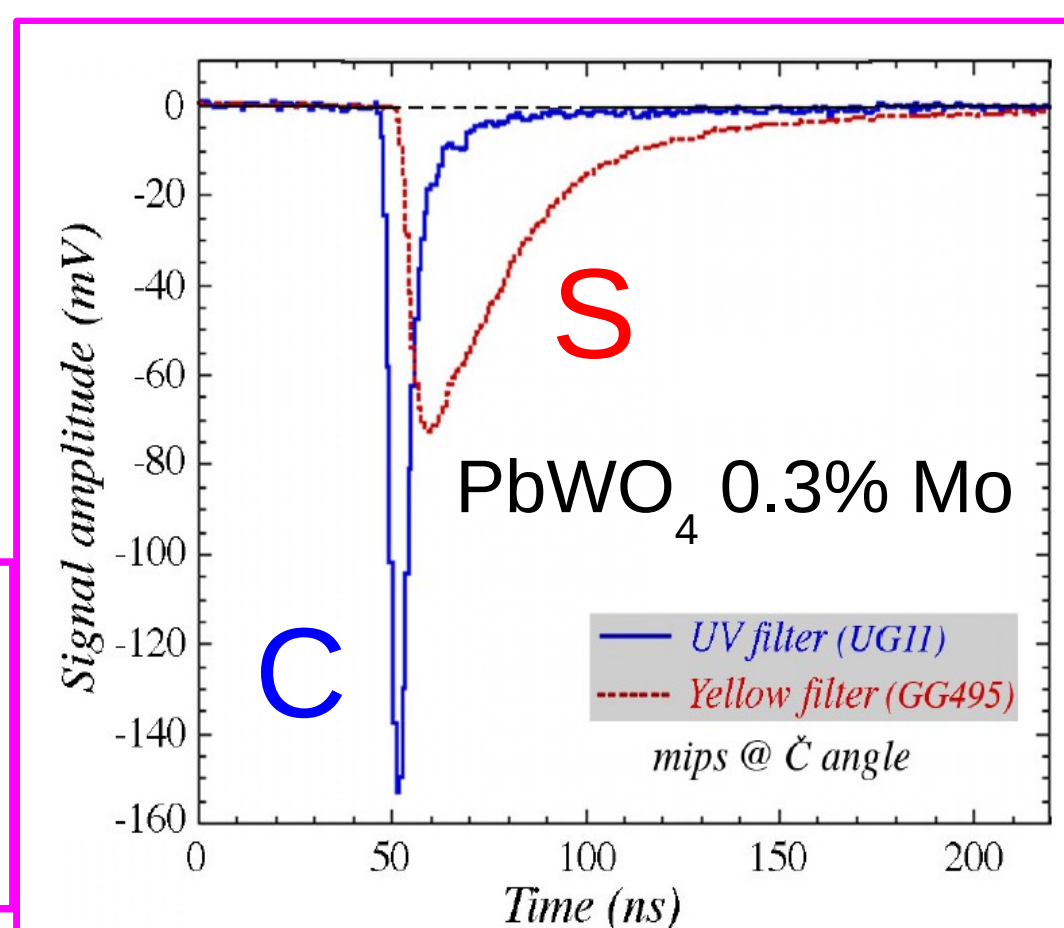

## Test beam setup and data acquisition

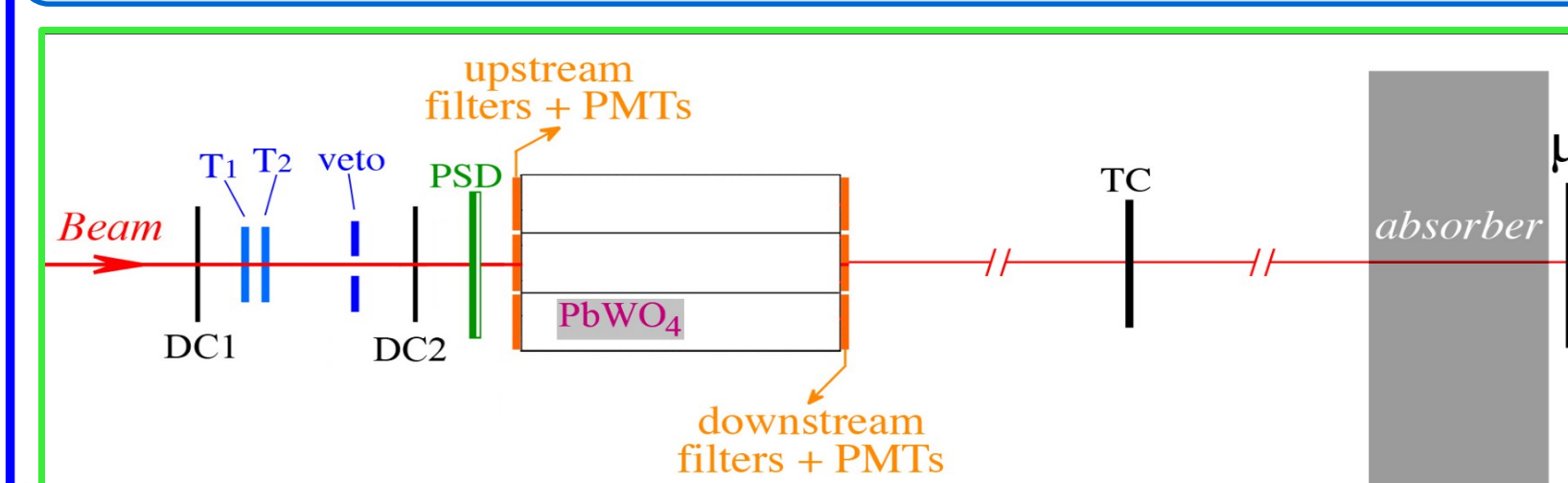

Data taken during testbeam periods in 2011 at the H8 beam line at the SPS at CERN.

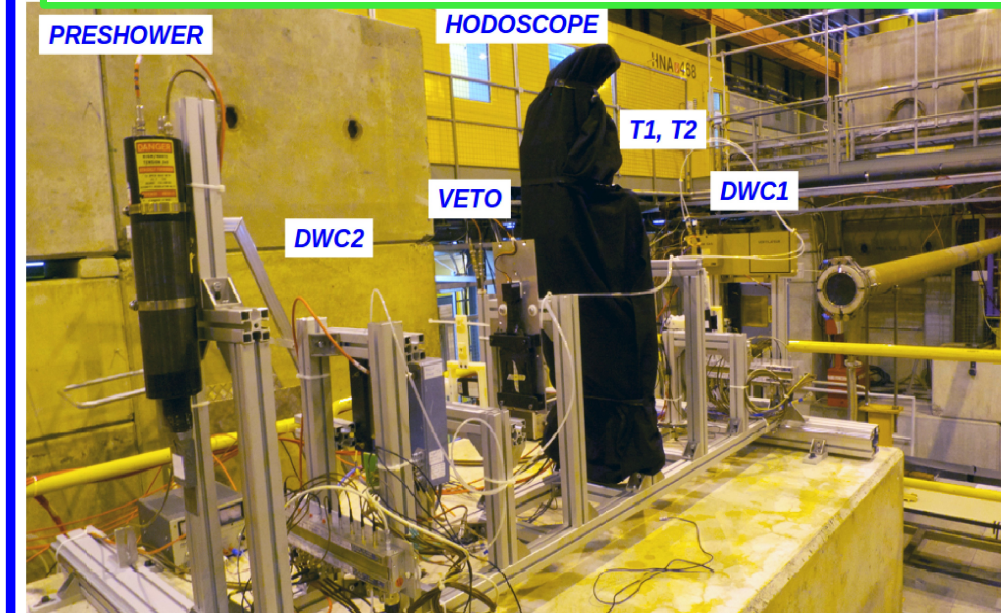

- Beam position: 2 Delay Wire Chambers (DWC)
- Trigger: FPGA based logic, 2 scintillators + 1 veto
- Beam cleaning: preshower (PS), tail catcher (TC), muon ( $\mu$ )
- Detector: crystal matrix, BGO and PbWO<sub>4</sub>
- Beam: electrons from 4 to 180 GeV

- Shaped output of the trigger is fed to a Xilinx Spartan-3AN FPGA. It handles trigger and busy logic.
- Trigger generated by the FPGA is sent to the CAEN V1742 digitizer. It acquires the output of the matrix PMTs and is readout through its own dedicated optical link.
- V1742 based on the DRS-IV chip: 8+1 channels sampler, GHz range sampling and a 1024 cells buffer.
- Sampling frequency set at 5 GS/s.
- Effective bandwidth of the system is estimated to be larger than 500 MHz.

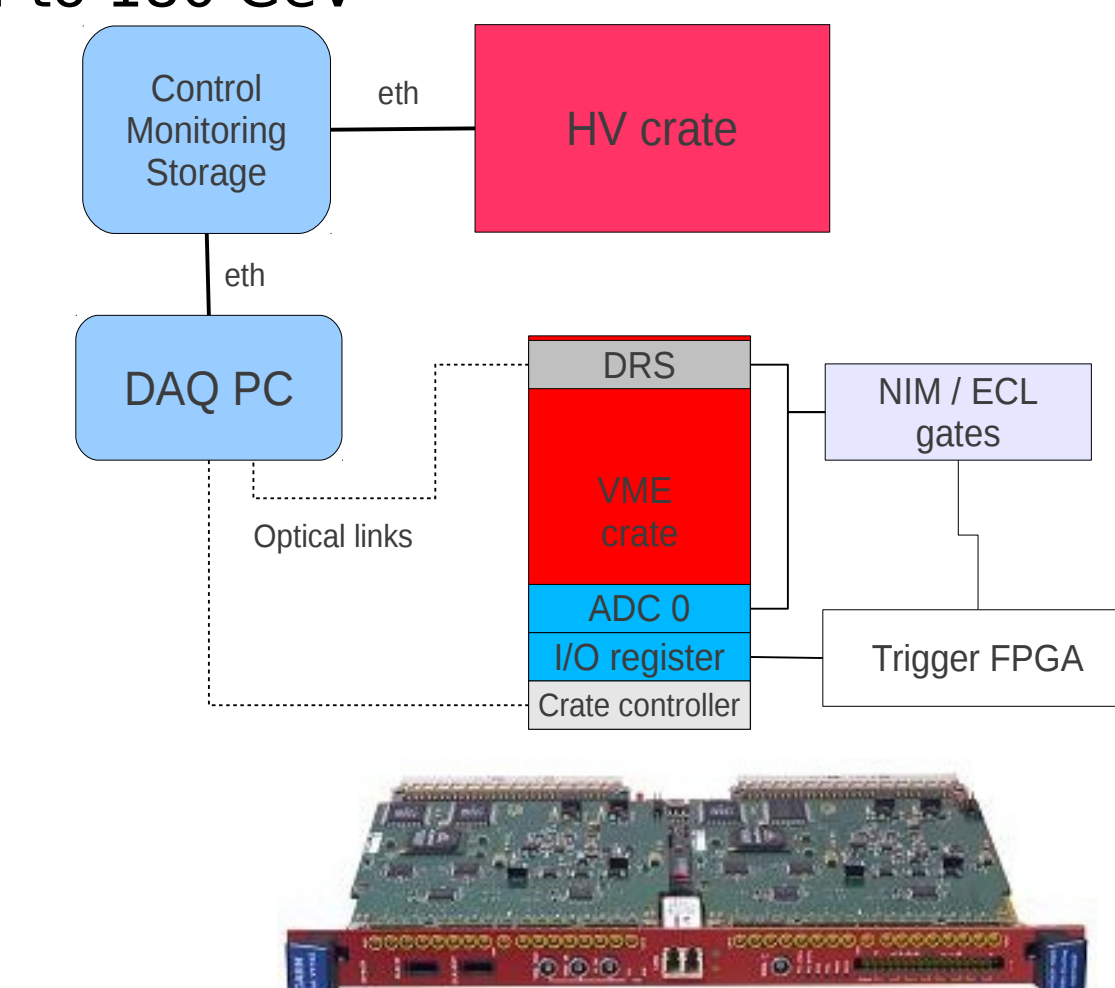

## BGO matrix

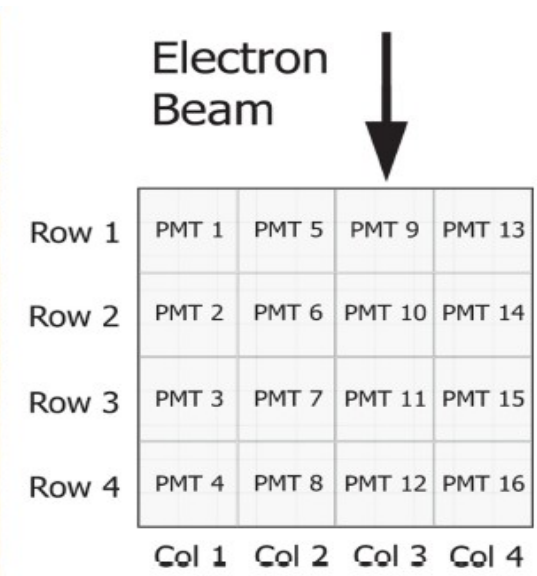
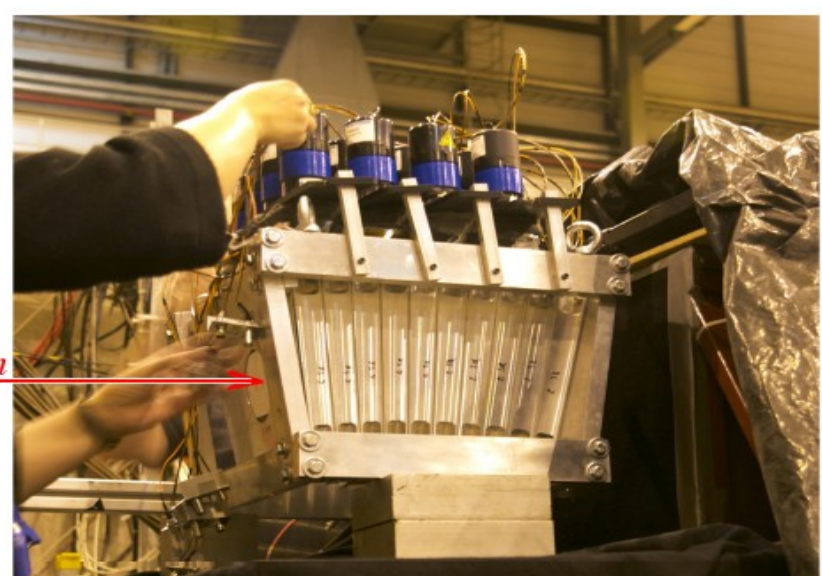

100 BGO (Bi<sub>4</sub>Ge<sub>3</sub>O<sub>12</sub>) crystals from a projective tower of the L3 experiment

- 24 cm long and tapered
- End faces: 2.4x2.4 cm<sup>2</sup>, 3.2x3.2 cm<sup>2</sup>
- Effective thickness: 28 cm, 25 X<sub>0</sub>
- 16 PMTs Hamamatsu R1355 (each PMT collected light produced by clusters of at least 9 adjacent crystals.)
- UG11 filters used
- Signal integrated over different time windows in order to extract C (fast component) and S (slow)

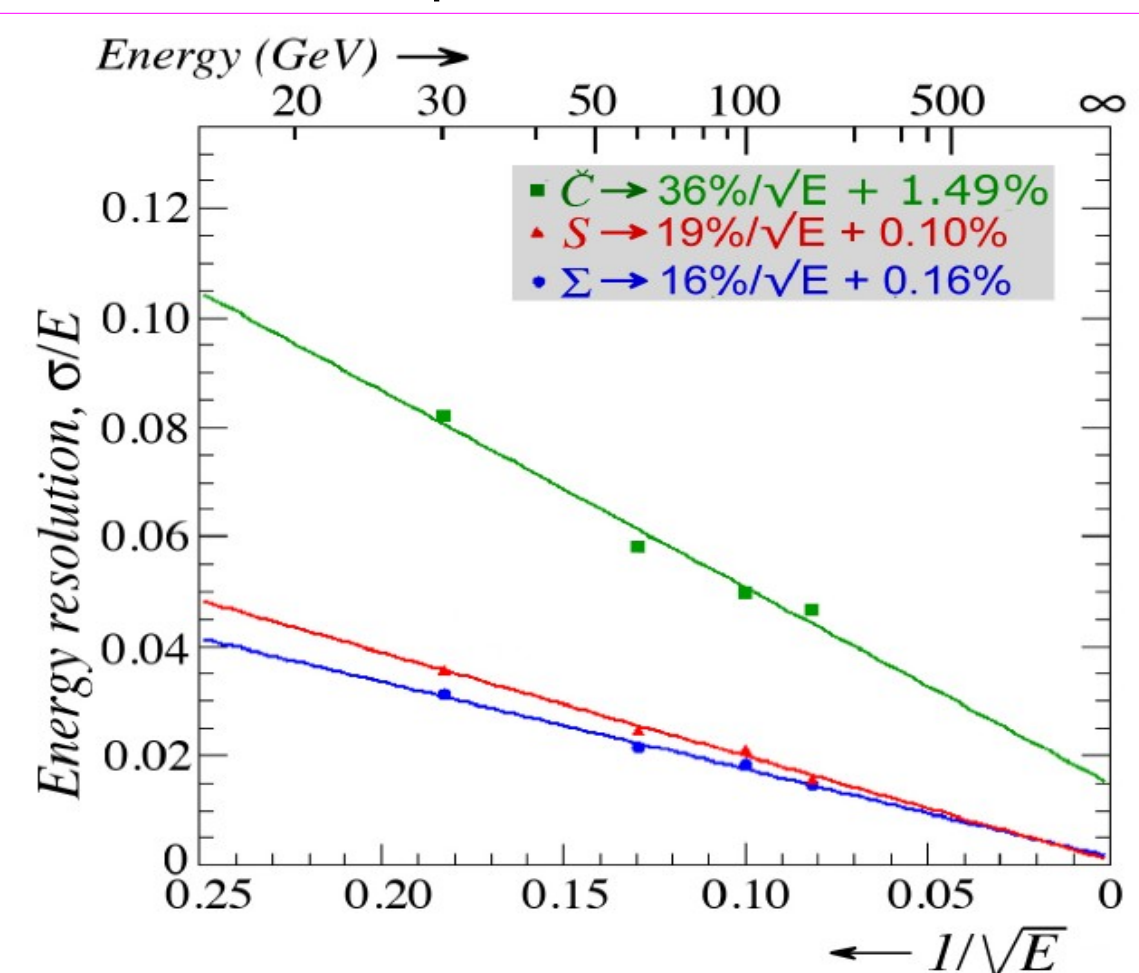

Energy resolution for electrons in the BGO matrix, as a function of the energy of the showering particles.  $\Sigma$ : charge collected by the PMTs. Also shown are the results of fits  $\sigma/E = aE^{-1/2} + b$

The calorimeter is reasonably linear (~ 3%) for both light components.

## PbWO<sub>4</sub> matrix



7 custom made PbWO<sub>4</sub> crystals doped with 0.3% Molybdenum (Radiation Instruments & New Components company, Minsk, Belarus)

- 3x3x20 cm<sup>3</sup> (22.5 X<sub>0</sub>)
- 2 PMTs for each crystal, 14 in total (Hamamatsu 8900)
- Several filter combinations:

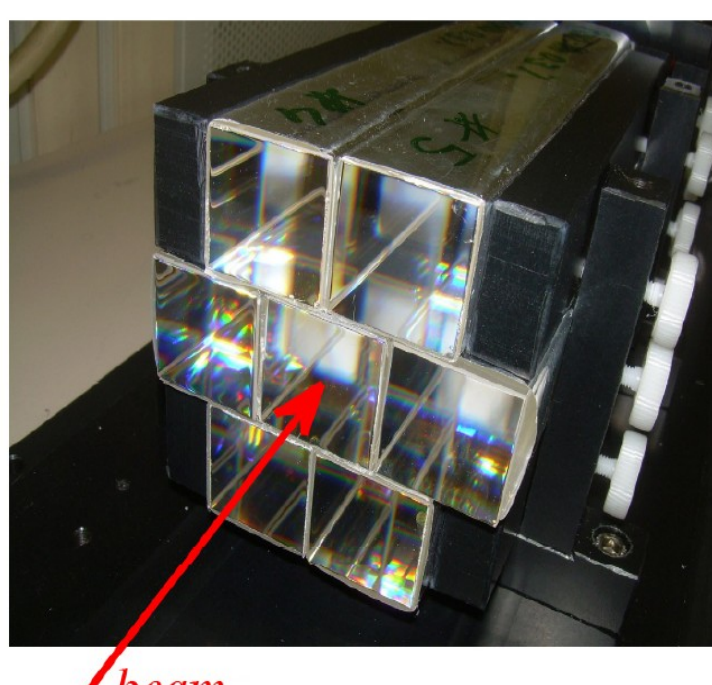

- Upstream GG495 (yellow), downstream U330:
  - good for S: measured resolution: ~ 1% for 100 GeV electrons
  - poor for C due to self absorption with the reading of C only on one side. Strong non linearity as energy increases. Need to sum up and down PMTs signals to eliminate this effect.
- Upstream UG5 (blue), downstream U330
  - good for C: sum of two sides, reduction of effects of self absorption. Linearity at 3%
  - poor for S: S extracted from the tail of the time structure, hence few photoelectrons.
- U330 both sides
  - good for C (sum of two sides),
  - almost no S signal

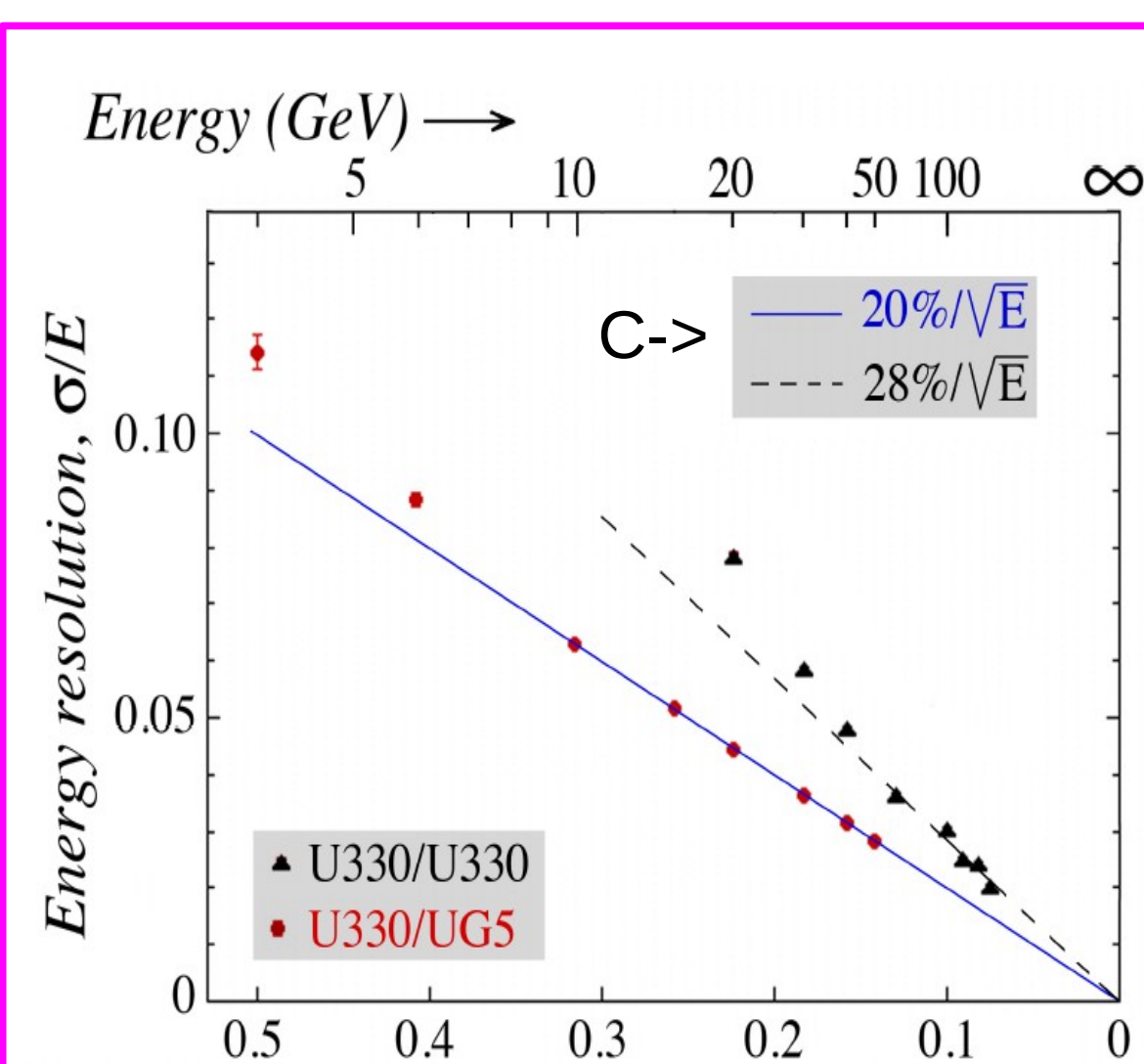

Energy resolution of C signal for electrons showering in the crystal matrix, as a function of energy. Signal derived from different combinations of UV-filtered light detected at both ends of the crystal matrix.

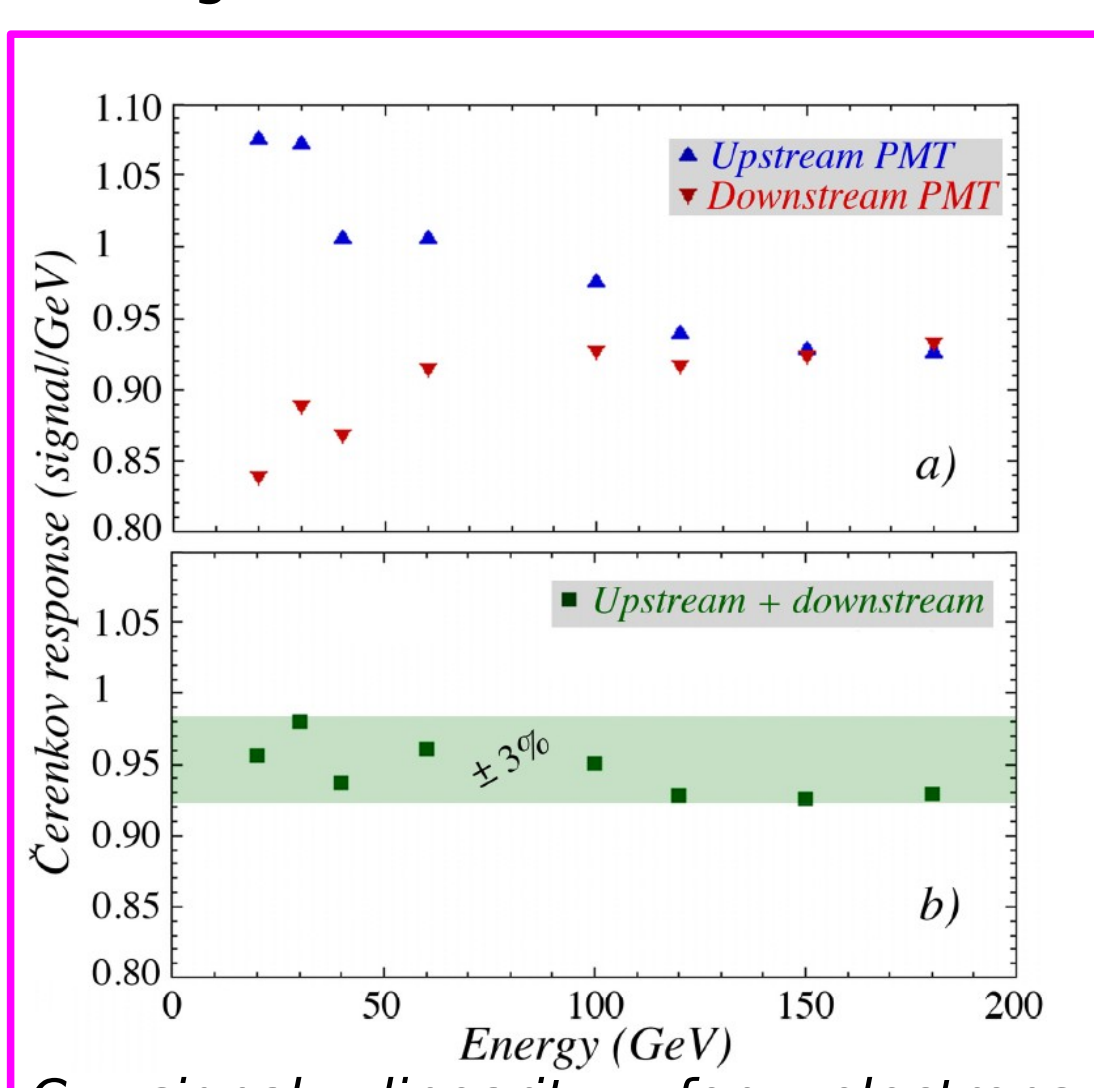

C signal linearity for electrons detected in the crystal matrix. U330 filters at both sides. Signals measured separately at both ends (a) and added together (b). Response is less than 1 due to leakages.

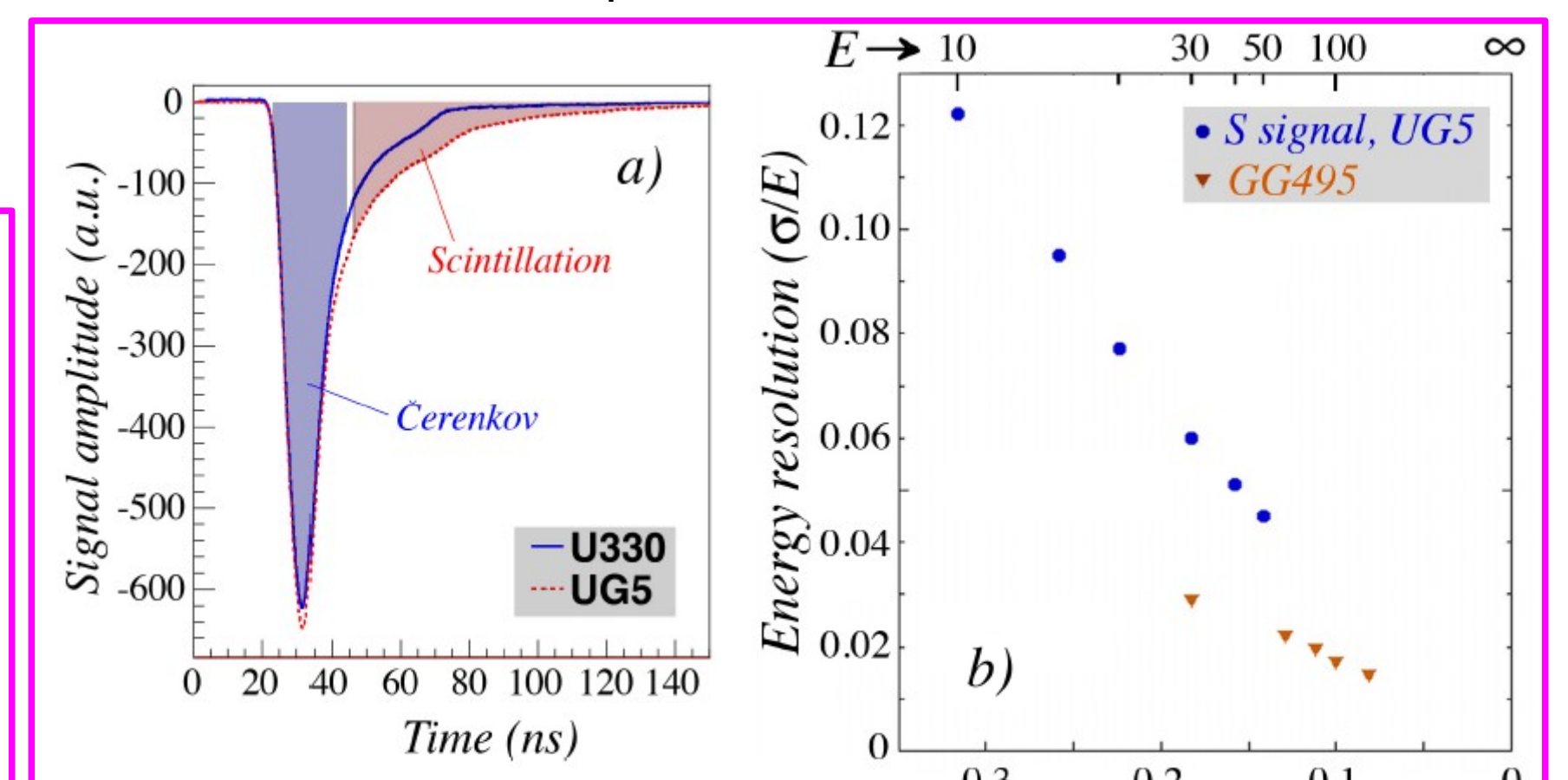

a) The average time structure of 30 GeV electron signals measured with the matrix equipped with a U330 filter or a UG5 filter. The latter transmits also a significant fraction of the scintillation light. Light collected in a time window of 20 ns around the peak is considered C, light collected more than 15 ns beyond the peak is as S.  
b) Energy resolution for S signal obtained both using GG495 filter and UG5 one.

Unlike in the BGO matrix, no evidence was found for an energy independent contribution ("constant term") to the energy resolution.

## Conclusions

- In order to use crystals for the dual readout calorimetry, crystals are not used in the conventional way, and this leads to not optimal results in terms of energy resolution of separated C and S components.
- Extracting sufficiently pure C signals from these scintillating crystals implies a severe restrictions to short wavelengths. A large fraction of the potentially available C photons needs to be sacrificed (by optical filters) but also the light that does contribute to the C signals is strongly attenuated (by UV self absorption).
- Our results show that the stochastic fluctuations in the C channel are at best 20%/√E in the case of our Mo-doped PWO crystal matrix. Assuming that these fluctuations are completely determined by photoelectron (p.e.) statistics, this would mean that the C light yield for the electron showers was 25 p.e./GeV deposited energy.
- Crystals in combination with filters does not seem to offer a benefit in terms of the C light yield in dual-readout calorimeters.
- We recently measured a light yield in excess of 50 C p.e./GeV in our new dual-readout fiber calorimeter; for these reasons, the fiber option has now a higher priority in the RD52 project.

## References

- N.Akchurin et al., NIM A604 (2009) 512
- N.Akchurin et al., NIM A621 (2010) 212
- N.Akchurin et al., NIM A640 (2011) 91
- S.Franchino, 2011 IEEE Nuclear Science Symposium Conference Record, N37-1
- N.Akchurin. et al, "Detection of electron showers in Dual-Readout crystal Calorimeters" just been accepted by NIM