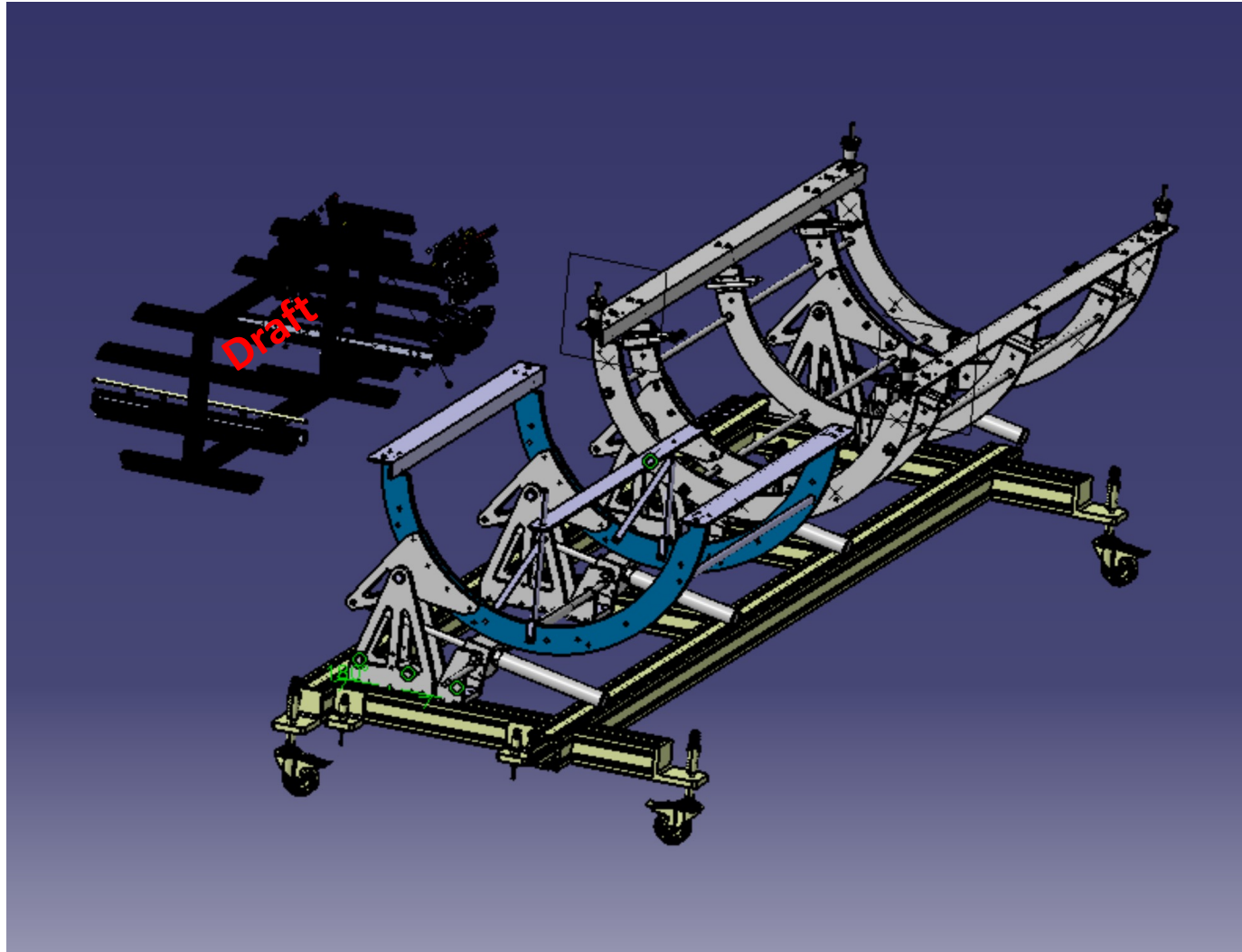

Design status of Service Trolley

Paolo Massarotti and Lorenzo Roscilli

INFN Naples

Service Trolley Design

Mechanical structure for placing and supporting cables during the integration



Service Trolley Design

Mechanical structure for placing and supporting cables during the integration

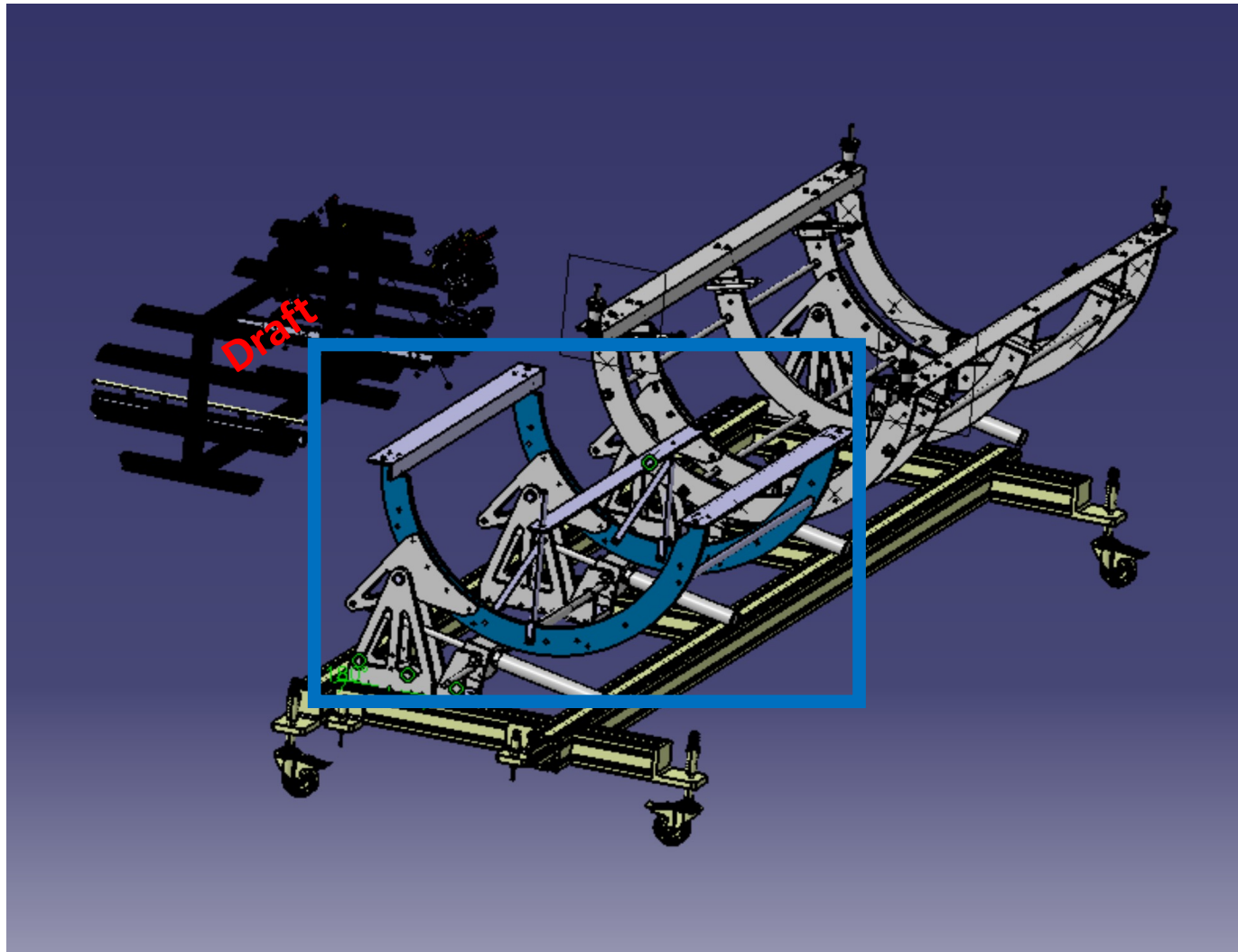

Service Trolley Design

Mechanical structure for placing and supporting cables during the integration

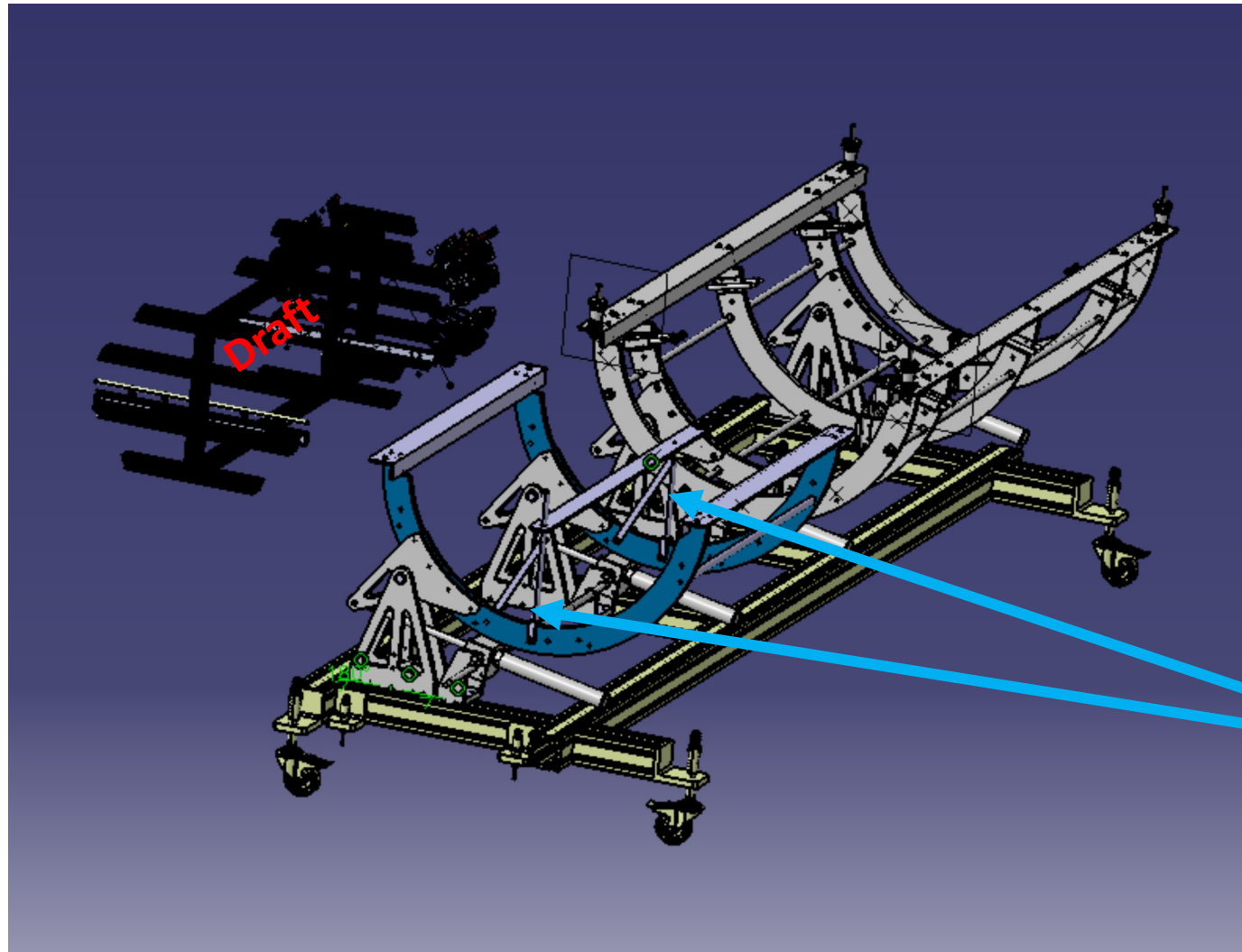

Support beams

Service Trolley Design

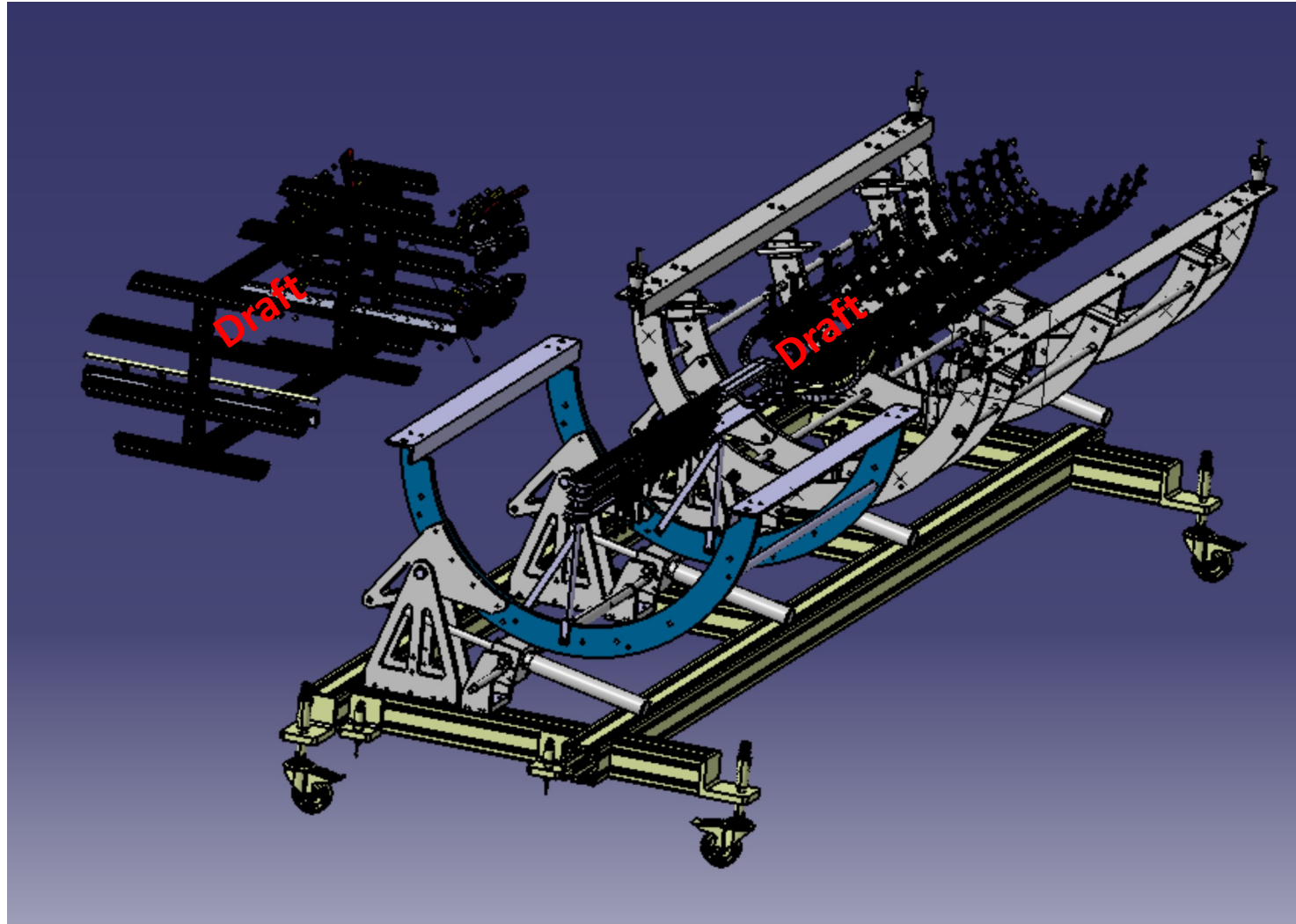

Service Trolley Design

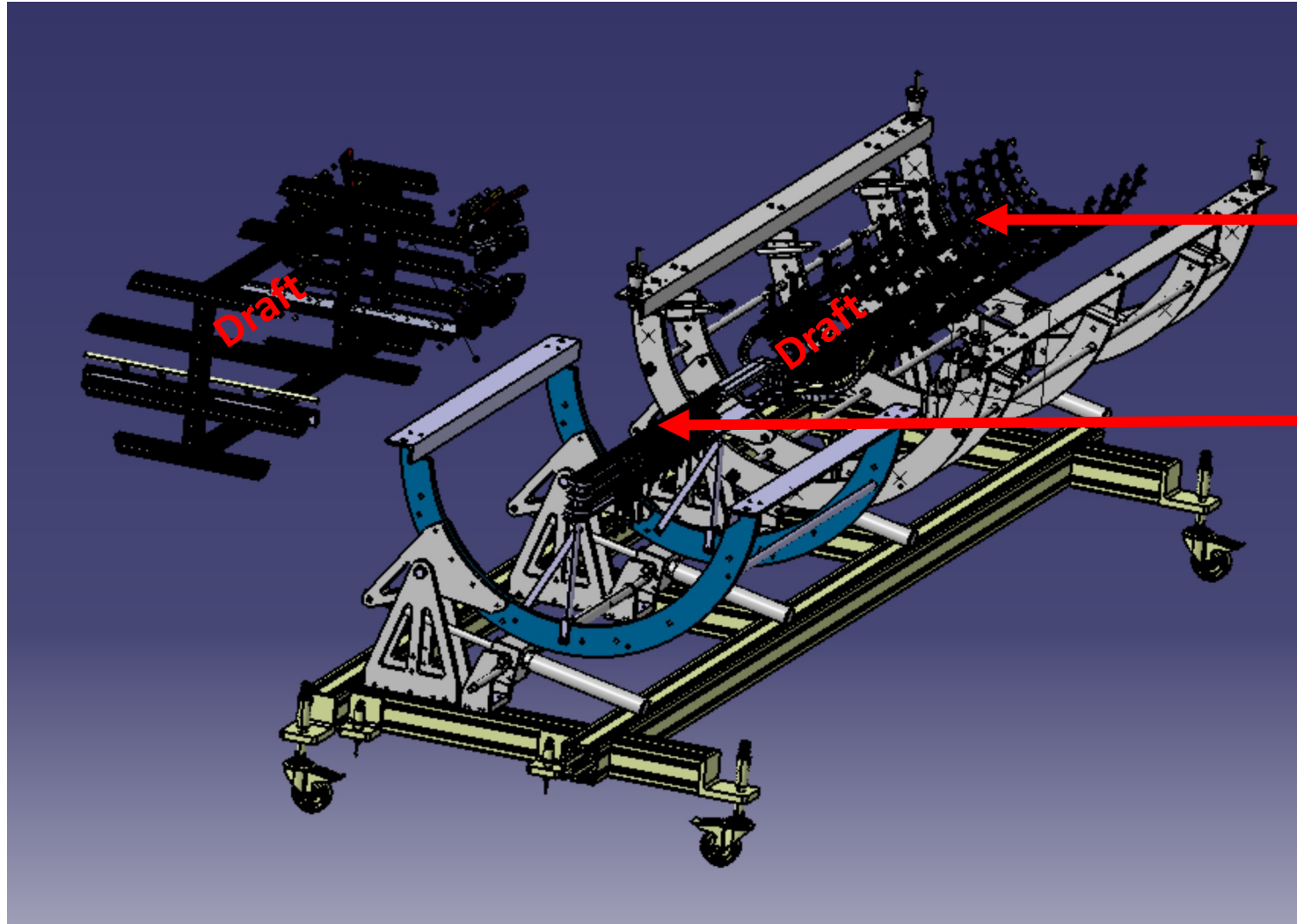

After half rings and cables positioning, after tests in climatic room

Service Trolley Design

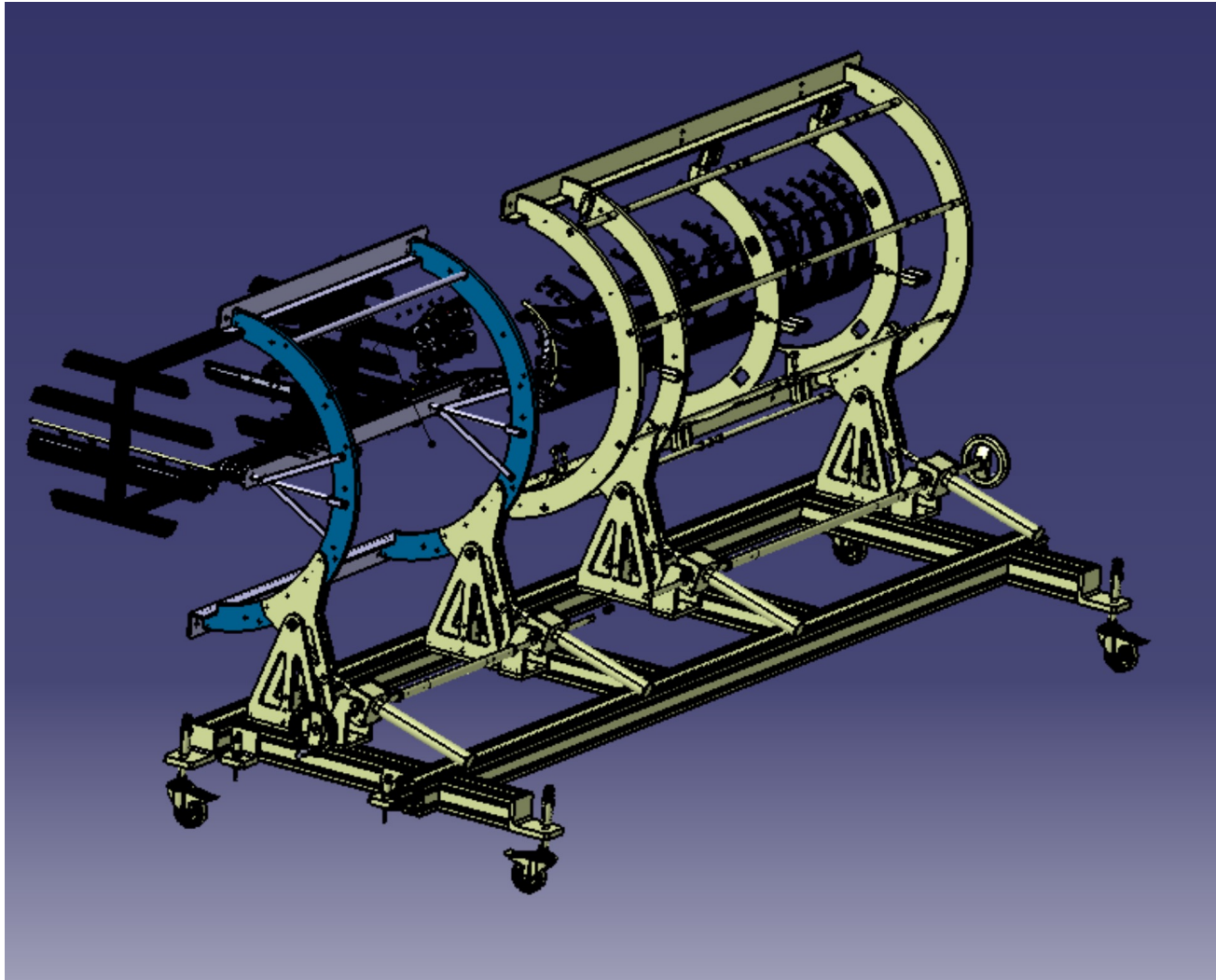

The structure is rotated by 90°

