

# ULTRA HIGH VACUUM TECHNIQUES

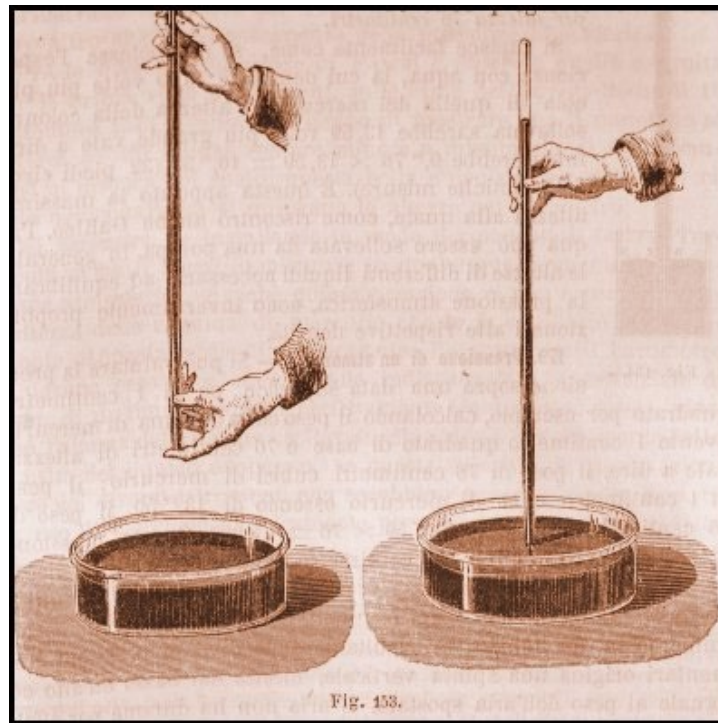

# Acknowledgements

This presentation contains the important concepts taken from:

- **Vacuum technology advanced lessons - Paolo Michelato** INFN Sezione di Milano Laboratorio Acceleratori e Superconduttività Applicata;
- **Pfeiffer Vacuum Know-How;**
- **Agilent Vacuum Products Catalog .**

# Index

- INTRODUCTION
  1. Vacuum Definition and Applications
  2. Pressure measurements and Vacuum classification
  3. Vacuum in particle accelerators
  
- BASIC CONCEPTS
  1. Mean free path and Gas Flow Regimes ( Transition, Molecular and Viscous)
  2. Gas flow rate and pumping speed
  3. Desorption, Outgassing and Degassing
  4. Leaks
  5. Throughput  $Q=p*S$
  6. Pumping Speed
  7. Residual Gas Composition
  8. Vacuum Conductance, Series and Parallel
  9. Electrical Analogy and Examples
  
- PUMPING TECHNOLOGY
  1. Primary pumping systems: Scroll Pump, Turbomolecular Pump,
  2. UHV pumping system: Ion Pump, Getter Pump,
  3. Vacuum Gauge
  4. Leak Detectors
  
- VACUUM SYSTEM DESIGN
  1. Materials
  2. Clean Process
  3. Laboratory experience description

# INTRODUCTION

1. Vacuum Definition and Applications
2. Pressure measurements and Vacuum classification
3. Vacuum in particle accelerators

# What is vacuum? How we define it?

- **Ideal**

Classical metaphysics: a space that contains nothing

- **Real**

Whatever has a pressure below atmospheric pressure



## • **In practice**

Any volume that has a number of gas molecules per unit of volume less than that of the atmosphere that surrounds.

- \* **Vacuum science** studies behavior of rarefied gases, interactions between gas and solid surfaces (adsorption and desorption), etc.
- \* **Vacuum technology** covers wide range of vacuum pumping, instrumentations, materials engineering, and surface engineering,...

# APPLICATIONS

a) To Avoid chemical and physical processes caused by atmospheric gases (e.g: during the fusion of particular reactive metals, like Ti,...)

e) Food and packaging, brazing in furnaces, sputtering processes..



b) To increase the mean free path of molecules, atoms and ions avoid the impacts with residual gas molecules (e.g: Metalization processes under vacuum, particles accelerators, ion implantation,...)

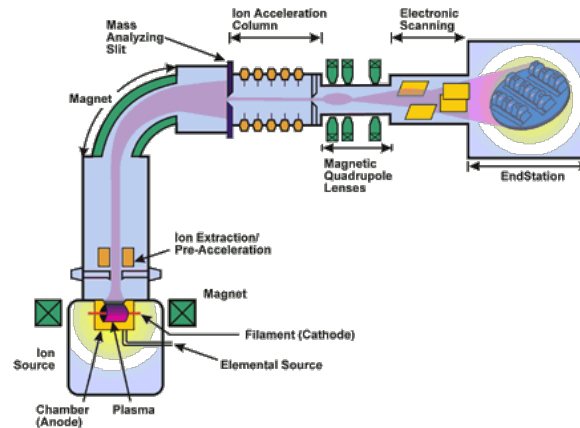

d) To simulate some particular physical situations (e.g. chamber of space simulation for test on satellites or space stations)

c) To increase thermal insulation ( e.g: in the Dewars, criogenics systems)

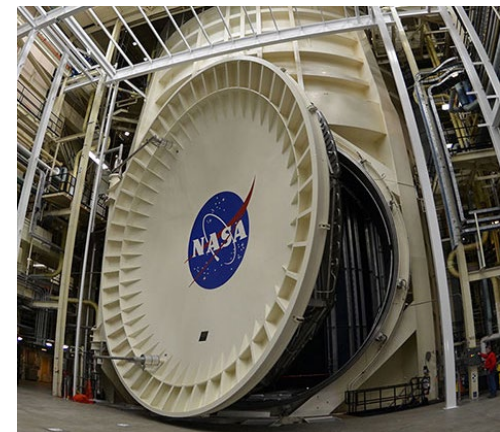

# Pressure measurements and Vacuum Classification

	Torr	mbar	Pa	micron	psi	atm
<b>1 Torr</b>	1	1,33	133	1000	$1,9 \times 10^{-2}$	$1,32 \times 10^{-3}$
<b>1 mbar</b>	0,751	1	100	750	$1,4 \times 10^{-2}$	$9 \times 10^{-4}$
<b>1 Pa</b>	$7,51 \times 10^{-3}$	$1 \times 10^{-2}$	1	7,5	$1,4 \times 10^{-4}$	$9 \times 10^{-6}$
<b>1 micron (mTorr)</b>	$1 \times 10^{-3}$	$1,3 \times 10^{-3}$	$1,3 \times 10^{-1}$	1	$1,9 \times 10^{-5}$	$1,3 \times 10^{-6}$
<b>1 psi (a)</b> <small>(libbre per pollice quadro)</small>	51,72	68,96	$6,89 \times 10^3$	$5,17 \times 10^4$	1	$7 \times 10^{-2}$
<b>1 atm</b>	760	1013	$1,01 \times 10^5$	$7,6 \times 10^5$	14,7	1

**Extreme UltraHigh Vacuum (XHV)**  
~ $10^{-12}$  mbar



**Low Vacuum (LV)**  
30 to  $10^3$  mbar

**Medium Vacuum (MV)**  
 $10^{-3}$  to 30 mbar

**Very High Vacuum (VHV)**  
 $10^{-6}$  to  $10^{-9}$  mbar

**Ultra High Vacuum (UHV)**  
 $10^{-9}$  to  $10^{-12}$  mbar

**High Vacuum (HV)**  
 $10^{-3}$  to  $10^{-6}$  mbar

Particles Accelerator -P~ $10^{-8}$ - $10^{-10}$  mbar

Industrials Scope



**NB:  $P=10^{-10}$  mbar ~  $10^6$  molecules/cm<sup>3</sup> !!!**

1 cm<sup>3</sup> of air at atmospheric pressure contains about  $10^{19}$  molecules



# Vacuum in Particle Accelerators

## 1) Circular machines like synchrotrons (multi-passage, high current)

The interaction between the residual gas and the particles beam can have several effects:

⇒ **reduction of beam lifetime** (because of scattering and energy lost by bremsstrahlung). The lifetime is proportional to  $1/P$  where the  $P$  is the residual gas pressure.

⇒ **instability** of the stored particles beam (ion trapping, fast ion instability)

⇒ **betatron tune variation**

⇒ **Increase in beam emittance**

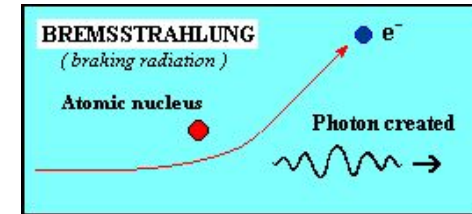
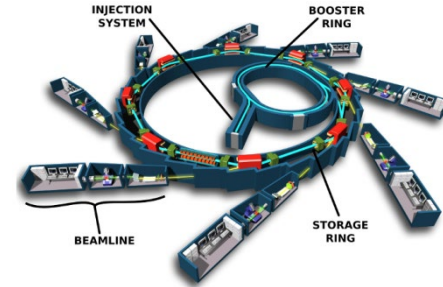

Typical vacuum pressures in synchrotrons are  $10^{-8}$ - $10^{-11}$  mbar

## 2) Linear accelerators (single-passage, low current)

In LINAC the vacuum requirements are less demanding because of the single passage (no cumulative effects) and less average current. The vacuum can still have impact on:

⇒ **Increase in beam emittance**

⇒ **discharges** in high gradient (10-100 MV/m) accelerating structures

⇒ **Contaminations** of targets, ...

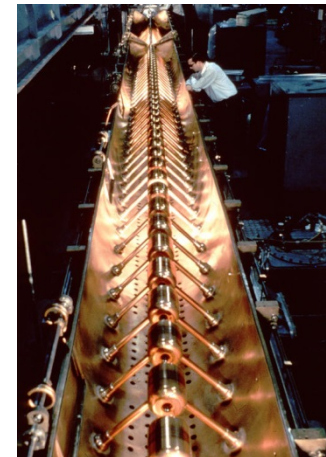

Typical vacuum Pressures are  $10^{-8}$ - $10^{-9}$  mbar



# BASIC CONCEPTS

1. Mean free path and Gas Flow Regimes ( Transition, Molecular and Viscous)
2. Gas flow rate and pumping speed
3. Desorption, Outgassing and Degassing
4. Leaks
5. Throughput  $Q=p*S$
6. Pumping Speed
7. Exercise
8. Residual Gas Composition
9. Vacuum Conductance, Series and Parallel
10. Electrical Analogy and Examples

# Gas Flow Regimes

The **mean free path** is the average distance that a gas molecule can travel before colliding with another molecule and is determined by:

- Size of molecule (2r)
- Pressure (p)
- Temperature (T)

$$\lambda_a = \frac{K}{\pi\sqrt{2}} \cdot \frac{T}{(2r)^2 p}$$

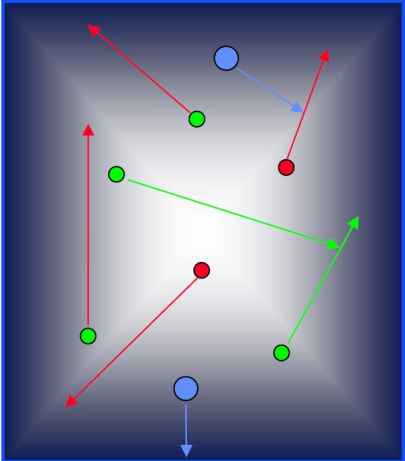

The gas in a vacuum system can be in a **viscous state**, in a **molecular state** (or in a transition state) depending on the dimension-less parameter know as the Knudsen number ( $K_n$ ) that is the ratio between the mean free path and the characteristic dimension of the flow channel.

$$K_n = \frac{\lambda_a}{a}$$

$\lambda_a$  = mean free path  
 $a$  = characteristic dimension of flow channel (typically a pipe radius)

Viscous Flow :  $Kn = \frac{\lambda_a}{a} < 0.01$

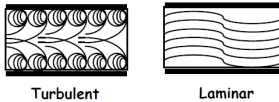

Transition Flow :  $0.01 < Kn < 1.0$

Molecular Flow :  $Kn > 1.0$

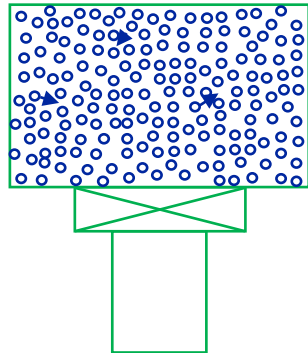
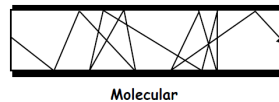

**Viscous Flow**  
 (momentum transfer between molecules)

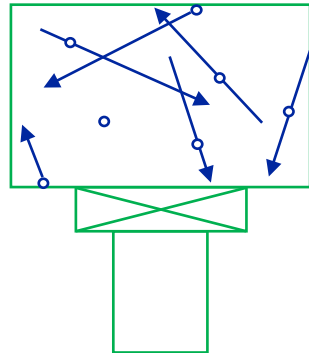

**Molecular Flow**  
 (molecules move independently)

$P > 1 \text{ mbar}$

$P < 10^{-3} \text{ mbar}$

Typical pressure values

# MEAN FREE PATH AIR @ 22°C

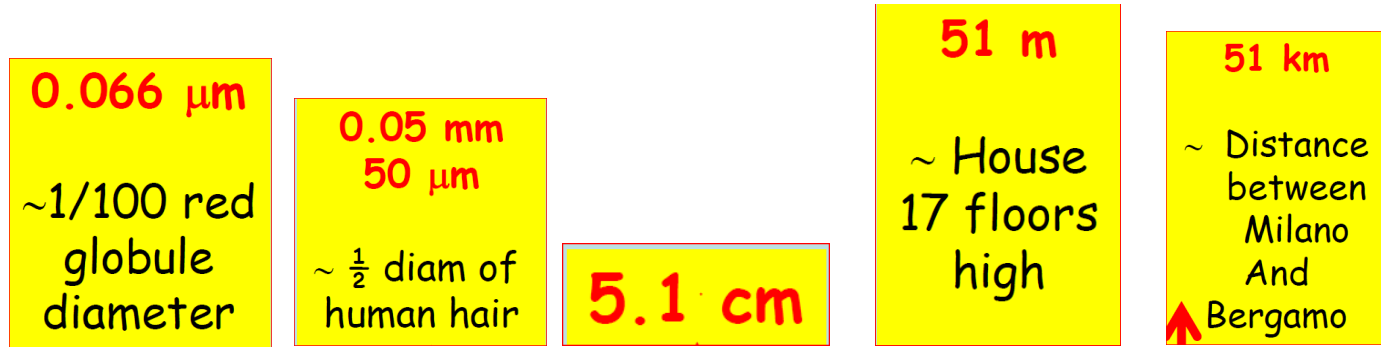

P(mbar)	1000	1,33	0,00133	$1,33 \times 10^{-6}$	$1,33 \times 10^{-9}$
$\lambda$ (cm)	$6,6 \times 10^{-6}$	$5,1 \times 10^{-3}$	5,1	5100	$5,1 \times 10^6$

# Gas flow rate and pumping speed

In a vacuum system (to the 1<sup>o</sup> order) the **total gas load** is the sum of several contributions.

The main important (for our typical applications) are:

1. **Desorption or outgassing** ( $Q_{des}$ );
2. **Leaks** (Real or Virtual,  $Q_L$ )

$$Q_{tot} = Q_{des} + Q_L$$

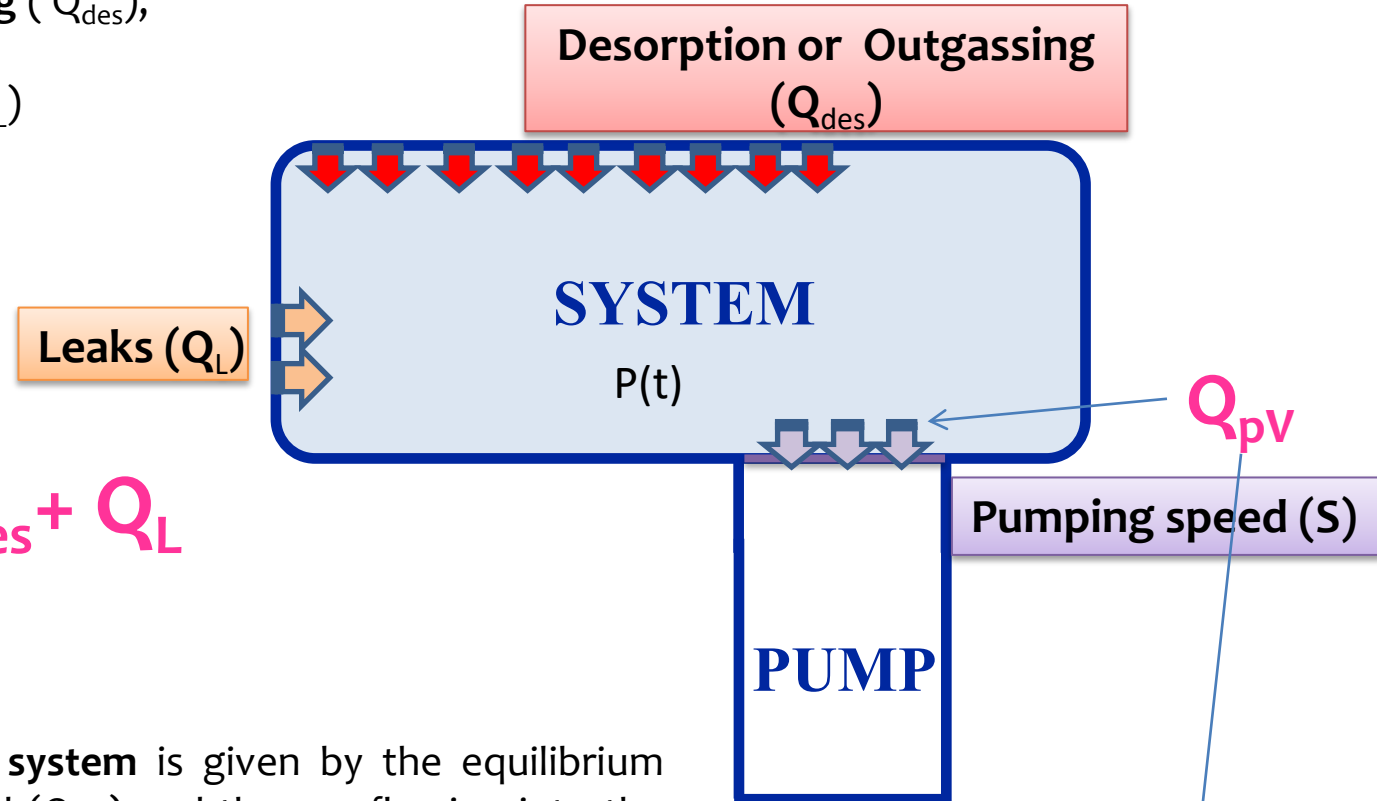

The **final pressure in the system** is given by the equilibrium between the total gas load ( $Q_{tot}$ ) and the gas flowing into the pump ( $pS$ ).

The pressure  $p(t)$  can be obtained solving this equation:

$$Q_{des}(t) + Q_L = p(t) \cdot S$$

# Desorption, outgassing, degassing

Gas molecules, (primarily water) are bound to the interior surfaces of the vacuum chamber and **gradually desorb again under vacuum**. The desorption rate of the metal and glass surfaces in the vacuum system produces a gas yield that decreases over time.

Outgassing is the **spontaneous** evolution of gas from solid or liquid.

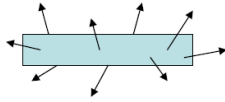

Degassing is the **deliberate** removal of gas from a solid or a liquid.

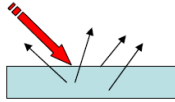

Desorption is the release of adsorbed chemical species from the surface of a solid or liquid.

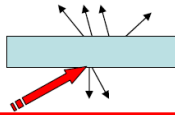

**Neoprene (10 h pumping):**

$$q_{\text{H}_2\text{O}} \approx 10^{-5} \text{ Torr } \ell \text{ s}^{-1} \text{ cm}^{-2}$$

$$q_{\text{H}_2\text{O}} = 3.3 \times 10^{14} \text{ molecules s}^{-1} \text{ cm}^{-2}$$

**Unbaked stainless steel (10 h pumping):**

$$q_{\text{H}_2\text{O}} = 2 \times 10^{-10} \text{ Torr } \ell \text{ s}^{-1} \text{ cm}^{-2}$$

$$q_{\text{H}_2\text{O}} = 6.6 \times 10^9 \text{ molecules s}^{-1} \text{ cm}^{-2}$$

**Baked stainless steel (150° C x 24 h):**

$$q_{\text{H}_2} = 2 \times 10^{-12} \text{ Torr } \ell \text{ s}^{-1} \text{ cm}^{-2}$$

$$q_{\text{H}_2} = 6.6 \times 10^7 \text{ molecules s}^{-1} \text{ cm}^{-2}$$

**Baked OFS Copper (200° C x 24 h):**

$$q_{\text{H}_2} = 2 \times 10^{-14} \text{ Torr } \ell \text{ s}^{-1} \text{ cm}^{-2}$$

$$q_{\text{H}_2} = 6.6 \times 10^5 \text{ molecules s}^{-1} \text{ cm}^{-2}$$

$$Q_{\text{des}}(t) = A * q_{\text{des}}(t)$$

$Q_{\text{des}}$	Desorption rate	[mbar l s <sup>-1</sup> ]
$q_{\text{des}}$	Desorption rate density or specific desorption rate	[mbar l s <sup>-1</sup> m <sup>-2</sup> ]
$A$	Area	[m <sup>2</sup> ]

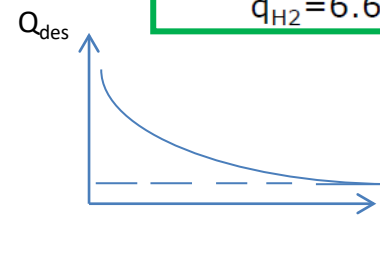

# Leaks

$Q_L$  describes the leak rate, i.e. a gas flow, which enters the vacuum system through leaks.

The leakage rate is defined as the pressure rise over time in a given volume:

$$Q_L = \frac{\Delta p \cdot V}{\Delta t}$$

$Q_L$	Leak rate	[mbar l s <sup>-1</sup> ]
$\Delta p$	Pressure change during measurement period	[mbar]
$V$	Volume of the system	[l]
$\Delta t$	Measurement period	[s]

# Gas flow rate and throughput of a vacuum pump

- **Gas flow rate** is the volume of gas, at a known pressure, that passes through a plane per unit time
- The **throughput of a vacuum pump** is the gas flow rate that a pump is able to absorb and is related to the pressure at the pump inlet:

This equation is directly obtained from the main ideal gas equation:  $PV=nRT$

P = Pressure of gas  
 V = Volume  
 n = number of molecules  
 R = Boltzman Constant (8,314472 J/mol K)  
 T = Temperature

$$\frac{dP}{dt}V + \frac{dV}{dt}P = \frac{dn}{dt}RT$$



$$\frac{dn}{dt} = \frac{1}{RT} \left( \frac{dP}{dt}V + \frac{dV}{dt}P \right)$$



$$Q = P \cdot S \quad [\text{mbar} \cdot \text{l/s}]$$

S is called pumping speed

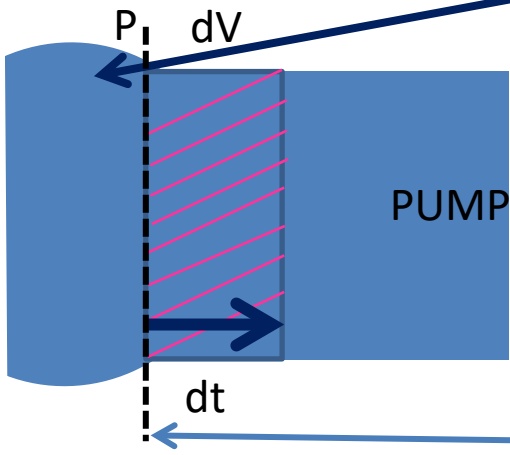

The lower the pressure, «Better» or «Higher» is the vacuum

Q is define as the quantity of gas that leaves the pipe in the unit time.

## General pumpdown equation

Amount of removed gas fm vessel  
(change of pressure in the vessel)

Gas Produced:  
**SOURCE** as outgassing

Quantity of gas that enters the pump

The diagram shows the general pumpdown equation:  $V \cdot \frac{dP}{dt} = Q_{tot} - S \cdot P$ . Three text boxes are positioned above the equation, each with an arrow pointing to a specific part of the equation. The red box on the left points to the  $V \cdot \frac{dP}{dt}$  term. The green box in the middle points to the  $Q_{tot}$  term. The blue box on the right points to the  $S \cdot P$  term.

$$V \cdot \frac{dP}{dt} = Q_{tot} - S \cdot P$$

In **stationary** conditions or **quasi-stationary** conditions, the **pressure variation** vs time is small and one can consider  $dp/dt \approx 0$ , therefore

$$Q_{tot} = S \cdot P$$



# Pumping Speed

(l/s, m<sup>3</sup>/h, cm<sup>3</sup>/s)

Is the volumetric flow (volume of gas per unit of time) through the pump's intake port, measured at the pressure p. Determination of the pumping speed is described in base standard ISO 21360-1

$$s = \frac{dV}{dt} \text{ [l/s]}$$

The pumping speed depends on the system pressure and gas type

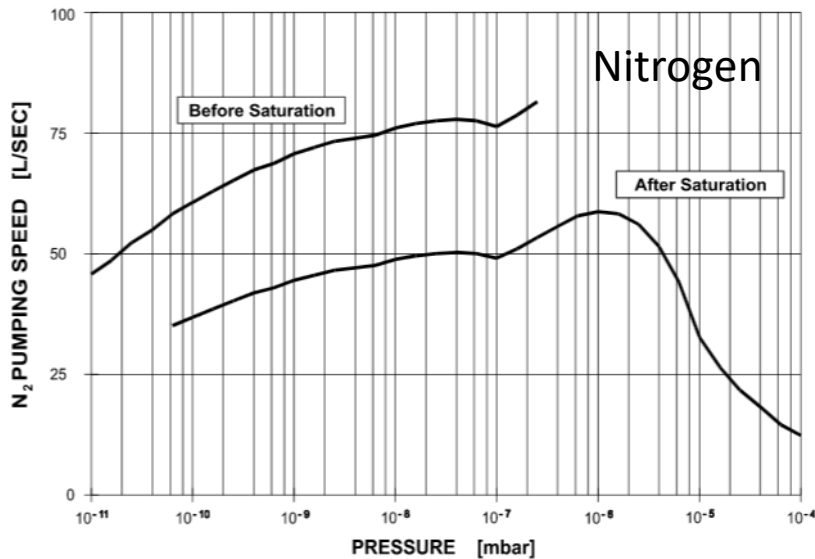

All pumps have both high and low applicable pressure limit

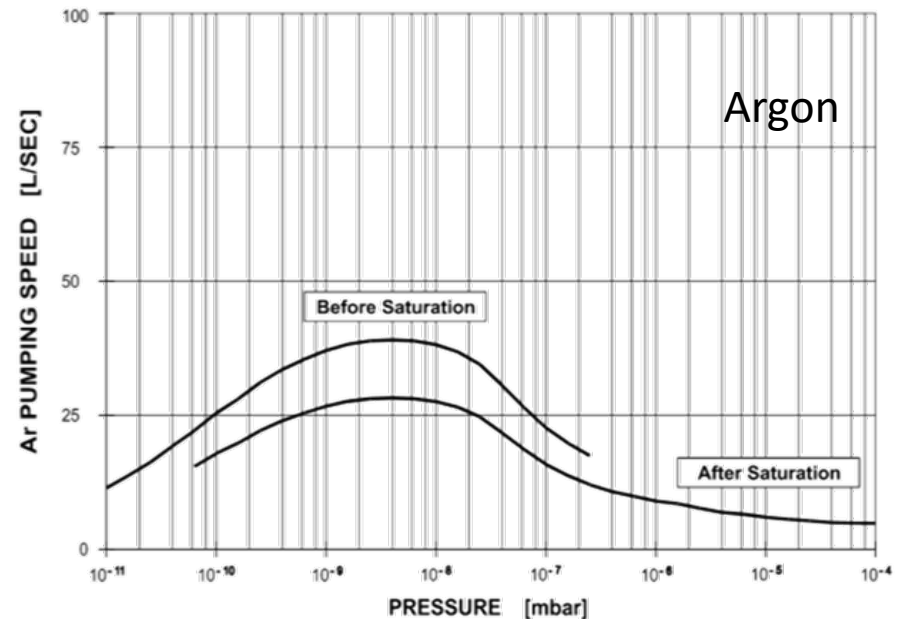

# EXAMPLE

## Fundamental equation for stationary conditions

**Q: 10 mbarl/s (10 scc/s)**  
**S pump : 16 m<sup>3</sup>/h = 16 / 3.6 l/s**  
**= 4.4 l/s**

? P<sub>eq</sub>?

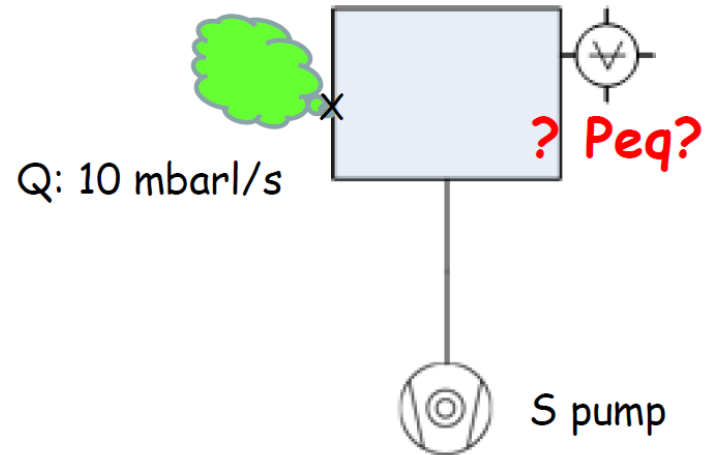

$$p_{eq}(\text{mbar}) = \frac{Q (\text{mbar} \cdot \text{l/s})}{S_p (\text{l/s})} = \frac{10 \text{ mbar} \cdot \text{l/s}}{4.4 \text{ l/s}} = 2.25 \text{ mbar}$$

$$p_{eq}(\text{mbar}) = \frac{Q (\text{mbar} \cdot \text{l/s})}{S_p (\text{l/s})}$$

# Residual Gas Composition

When working in ultra-high vacuum, it can be important to know the composition of the residual gas.

A residual gas analyzer (RGA) is a small and usually rugged mass spectrometer<sup>(\*)</sup>, typically designed for process control and contamination monitoring in vacuum systems.

As example the percentages of water ( $m/e = 18$ ) and its fragment OH ( $m/e = 17$ ) will be large in the case of vacuum chambers that are not clean or well baked.

**Leaks** can be identified by the peaks of nitrogen ( $m/e = 28$ ) and oxygen ( $m/e = 32$ ) in the ratio  $N_2/O_2$  of approx. 4 to 1. Hydrogen ( $m/e = 2$ ), water ( $m/e = 17$  and 18), carbon monoxide ( $m/e = 28$ ) and carbon dioxide ( $m/e = 44$ ) will be found in well-baked chambers.

No hydrocarbons have to be present in well cleaned chambers.

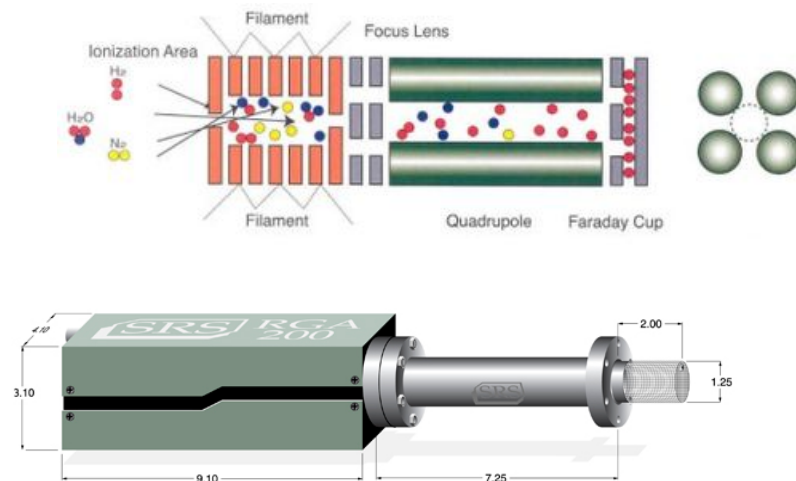
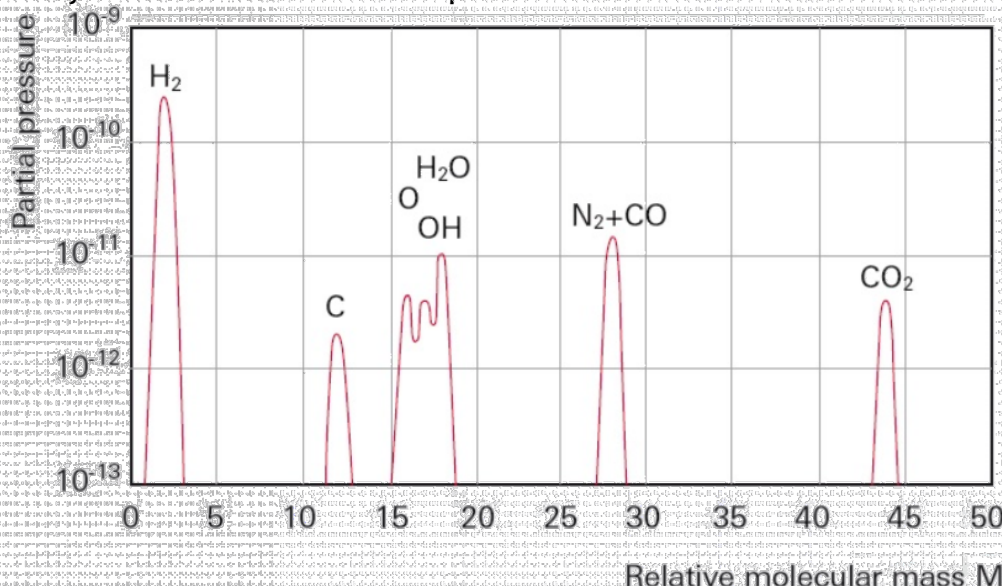

Typical residual gas spectrum of a vessel evacuated by a turbomolecular pump

# Vacuum Conductance

Gases moving through elements (pipes, tubes, vessels, and orifices) in a vacuum system **encounter resistance to their motion**. We can define the impedance of a tube as:

↓

$$Z = (P_1 - P_2) / Q$$

↘

$$C = 1/Z = Q / (P_1 - P_2)$$

Defines the pressure drop in a pipe

The Conductance is the capability to let through a particular gas volume in a known time

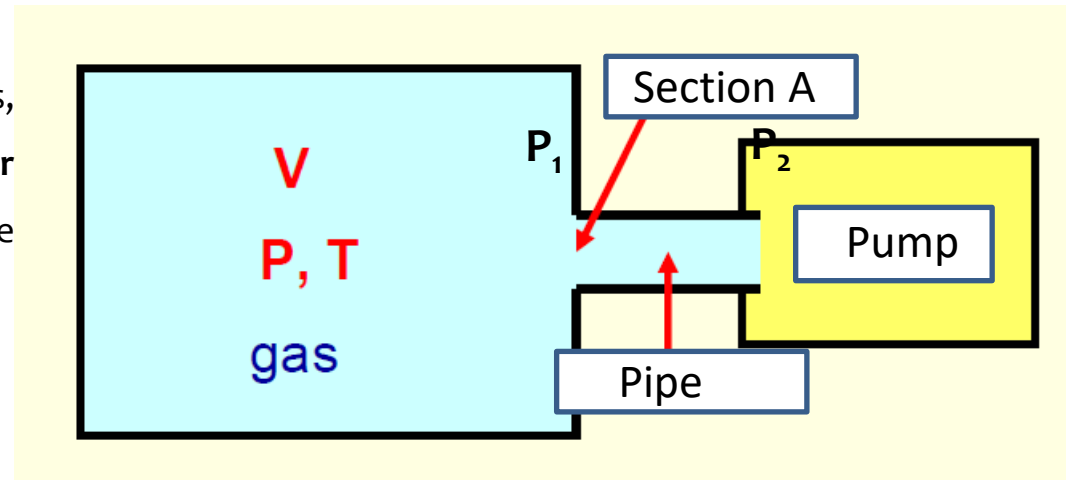

**Conductance is an abstract concept** used to describe the behavior of gas in a vacuum system.

- Conductance is specific to a particular **geometrical** configuration.
- **Conductance is specific to the actual gas species** and temperature.

## The problem of pipes between chamber and pump: the effective pumping speed

The pump can be connected to the chamber through pipes.

The conductance of these pipes may limit the pumping capacity of the pump and to lengthen the time or only allow the attainment of a final pressure higher (worst vacuum).

The equation above view will always be valid but it will be necessary to indicate and calculate the **EFFECTIVE** pumping speed in the vessel.

$$S_{\text{eff}} = \left( \frac{1}{S_p} + \frac{1}{C} \right)^{-1}$$

# Conductance Properties

The **conductance** of pipes and pipe bends will differ in the various flow regimes.

In **viscous flow** they are **proportional** to the **mean pressure  $p$**  and in **molecular flow** they are **independent of pressure**. Knudsen flow represents a transition between the two types of flow, and the conductivities vary with the Knudsen number.

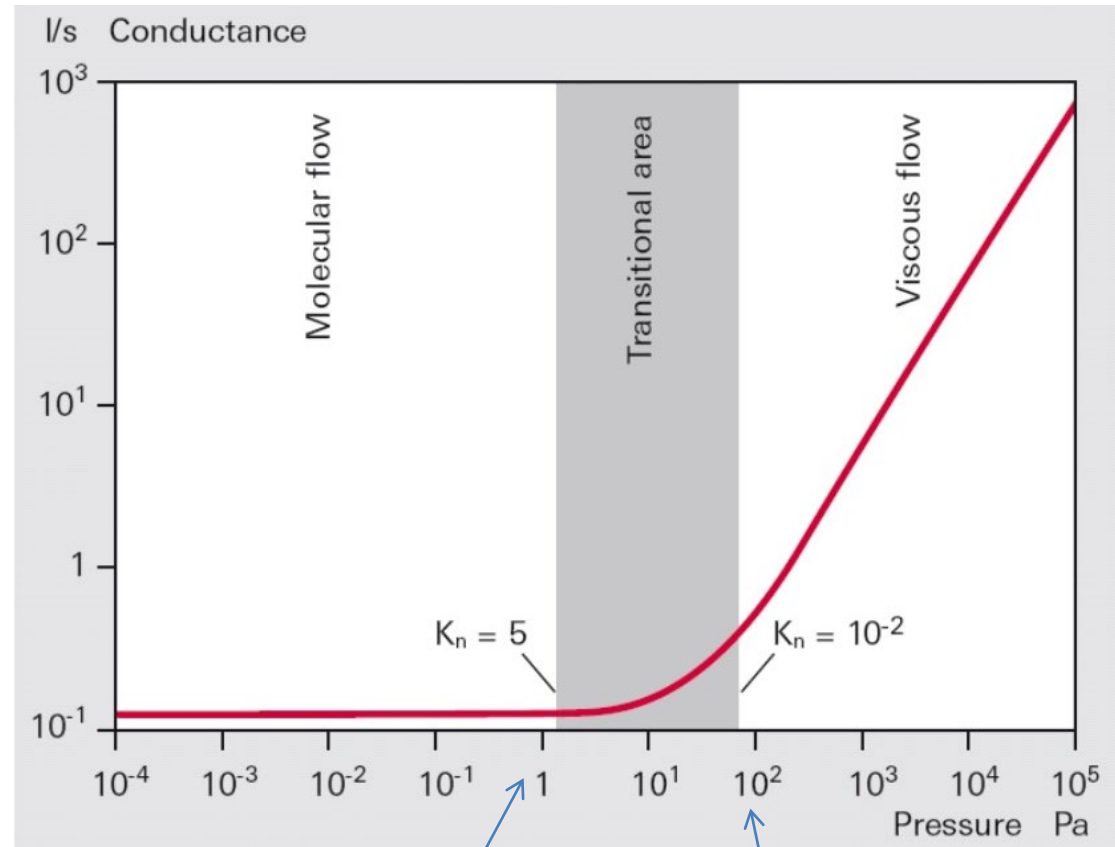

Conductance of a smooth round pipe as a function of the mean pressure in the pipe

$10^{-2}$  mbar

1 mbar

# Example:

## Conductance in Molecular Flow of a Long Round Tube

Under molecular flow conditions, doubling the pipe diameter increases the conductance eight times. The conductance is INVERSELY related to the pipe length.

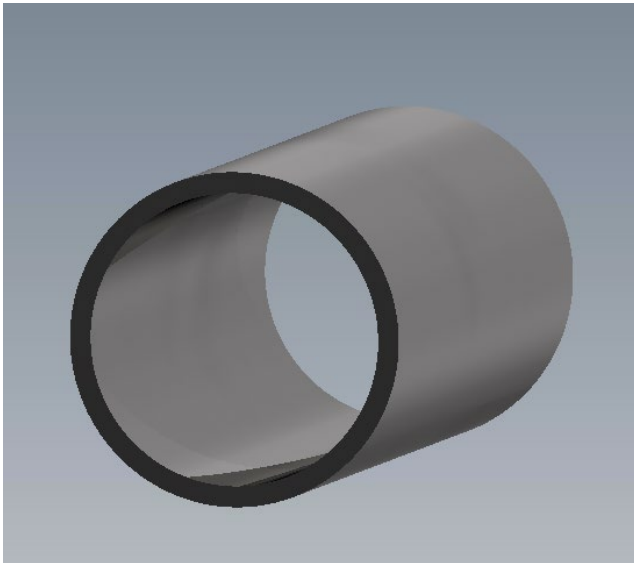

$$C = 3.81 \times \frac{d^3}{l} \times \sqrt{\frac{T}{M}} \quad (\text{l/sec})$$

d = diameter of tube in cm

l = length of tube in cm

T = temperature (K)

M = A.M.U.



# Example: Conductance in Molecular Flow for Air at 22°C

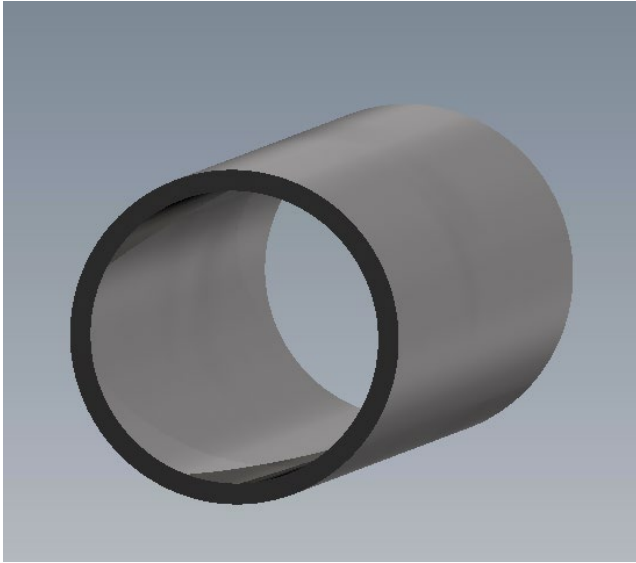

$$C = 3.81 \times \frac{d^3}{l} \times \sqrt{\frac{T}{M}} \quad (\text{l/sec})$$

d = diameter of tube in cm

l = length of tube in cm

T = temperature (K)

M = A.M.U.



Orifice

$$C [l/s] = 11.6 A$$

A = Area of the Orifice [cm<sup>2</sup>]

Long Round Tube

$$C [l/s] = 12.1 \frac{d^3}{l}$$

d = diameter [cm]

l = length [cm]



# Electrical Analogy of a Vacuum System (1/2)

A vacuum system can be analyzed/designed using an equivalent electrical model.

In this model:

1- pressures at a given point is the voltage

2- gas flow rate  $Q$  is the current

3- the conductances are electrical resistors

4- the pumping system are voltage generator

5- leaks as resistors that connect a given point to the mass.

$$I = \Delta V / R = I = \Delta V * G \Rightarrow Q = \Delta P * C$$

## Conductances in Series

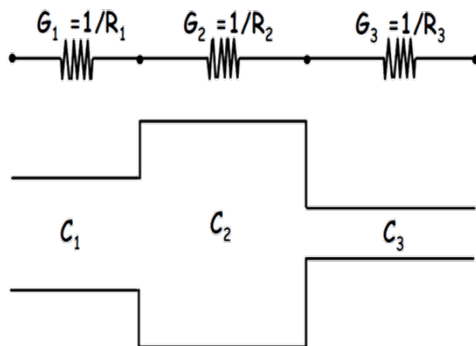

$$\frac{1}{G_e} = \frac{1}{G_1} + \frac{1}{G_2} + \frac{1}{G_3}$$

$$\frac{1}{C_{Total}} = \frac{1}{C_1} + \frac{1}{C_2} + \frac{1}{C_3}$$

## Conductances in Parallel

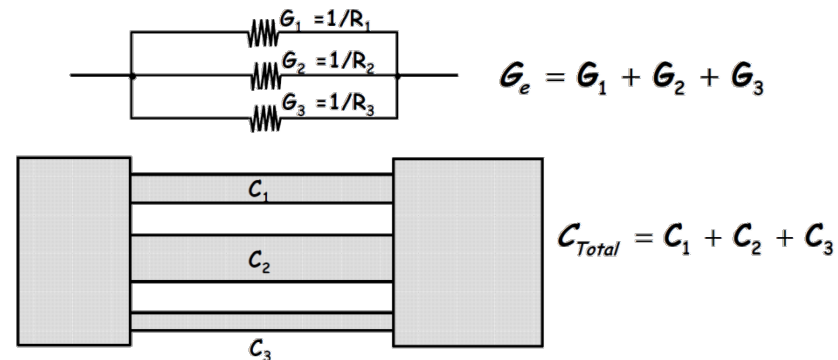

$$G_e = G_1 + G_2 + G_3$$

$$C_{Total} = C_1 + C_2 + C_3$$

# Pumping Technology

1. Primary pumping systems: Scroll Pump, Turbomolecular Pump,
2. UHV pumping system: Ion Pump, Getter Pump, Titanium Sublimation Pump
3. Vacuum Gauge and Leak Diagnostic

# Pumping Technology

## Overview of vacuum pumps

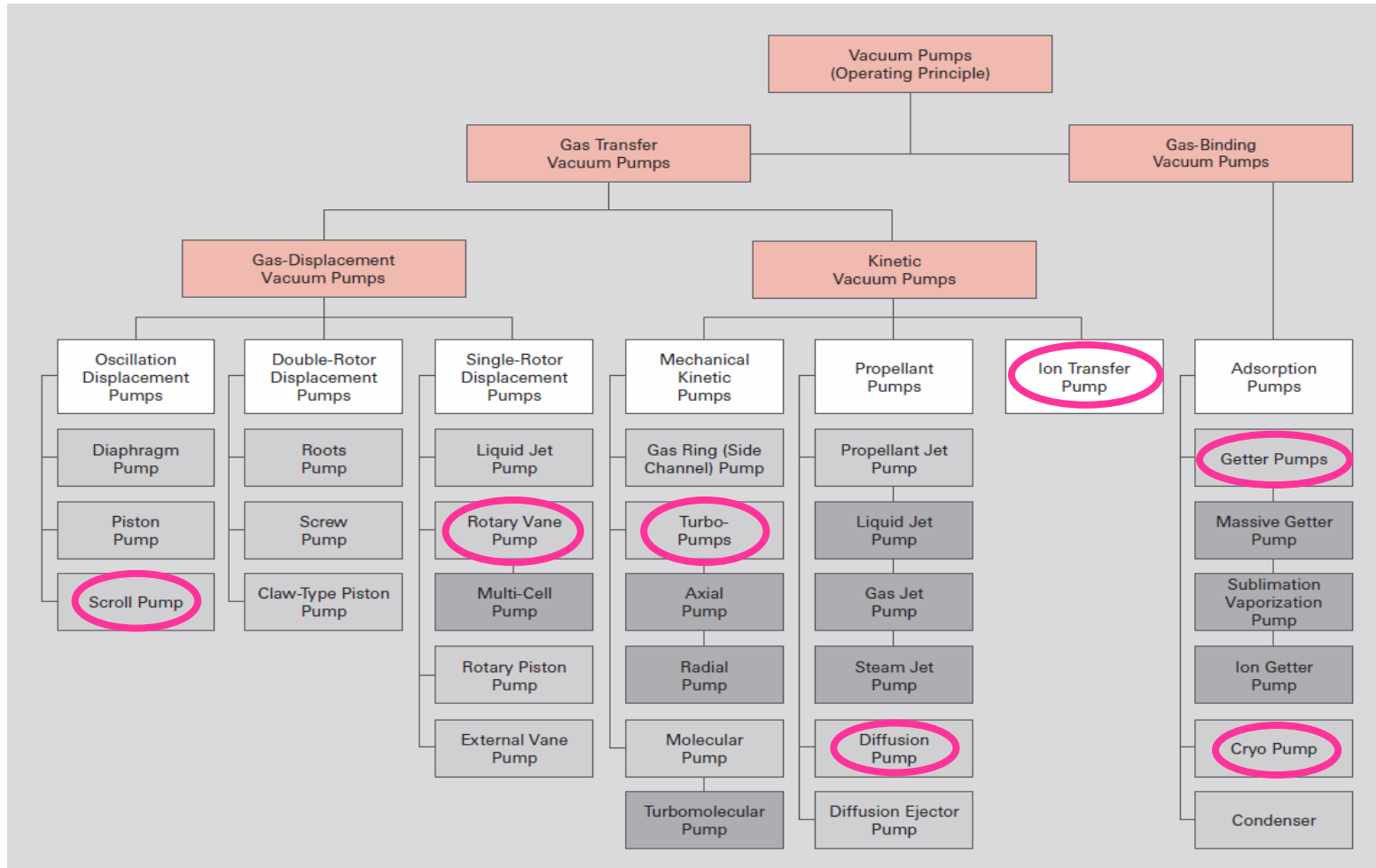

# Pumping Technology

a) **Primary pumping systems** are mechanical pumps that work to decrease the pressure from atmospheric pressure to the pressure ( $10^{-6}$ - $10^{-8}$ ) to start the ion pump or other UHV pumping systems. We have:

- **Scroll Pump** ( atmospheric pressure to about  $10^{-3}$  mbar)
- **Turbomolecular Pump** ( from  $10^{-2}$  mbar to about  $10^{-8}$  mbar )

b) **UHV pumping system** are the pumps that work at low pressure or in ultra high vacuum. The typical pumps are :

- **Ion Pump** (from  $10^{-6}$  mbar to  $10^{-11}$  mbar)
- **Getter Pump**
- **Titanium Sublimation Pump**

⇒ In particles accelerator ion, Ti Sublimation and NEG pumps are in general used.

⇒ **Different pumps are more effective for different chemical species.**

⇒ In a vacuum system we find these typical gases:

Nitrogen N<sub>2</sub>, CO, CO<sub>2</sub>, methane , Argon , Oxygen , Hydrogen, Helium, Water ..

# Scroll Pump

A **scroll compressor** (also called *spiral compressor*, **scroll pump** and **scroll vacuum pump**) is a device for compressing air or refrigerant. It is used in air conditioning equipment, as an automobile supercharger (where it is known as a scroll-type supercharger) and as a vacuum pump.

A scroll compressor uses **two interleaving spirals that allow to physically remove the gas from the system.** It allows to reach pressure of the order  $10^{-2}$ - $10^{-3}$  mbar .

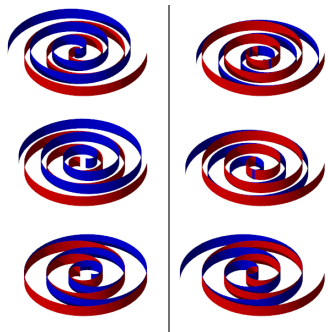

These devices are known for operating more smoothly, quietly, and reliably than conventional compressors in some applications

# Turbomolecular Pump

A **turbomolecular pump** is a type of vacuum pump, used to obtain and maintain high vacuum.

- These pumps work on the principle that gas molecules can be given momentum in a desired direction by repeated collision with a moving solid surface.
- In a turbomolecular pump, a rapidly spinning fan rotor (50000-100000 rpm) 'hits' gas molecules from the inlet of the pump towards the exhaust in order to create or maintain a vacuum.



Interior view of a turbomolecular pump

- These pumps can be a very versatile pump. It can operate from **intermediate vacuum** ( $\sim 10^{-2}$  mbar) up to **ultra-high vacuum levels** ( $\sim 10^{-8}$  mbar).

Schematic of a turbomolecular pump.

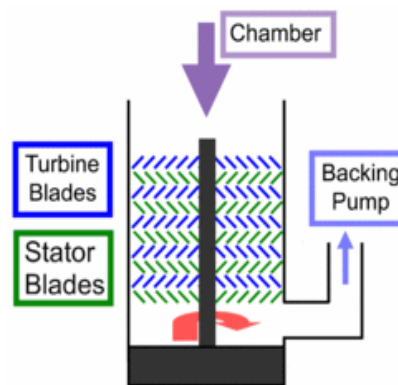

Their design is similar to that of a turbine. A multi-stage, turbine-like rotor with bladed disks rotates in a housing.

# *Ion Pump (1/2)*

An **ion pump** (also referred to as a **sputter ion pump**) is a type of vacuum pump capable of reaching pressures **as low as  $10^{-11}$  mbar under ideal conditions**. An ion pump ionizes gas within the vessel applying a strong electrical voltage, typically 3–7 kV, which allows the ions to accelerate and be captured by a solid electrode.

Ion pumps and are available in four types:

- StarCell
- Triode
- Noble Diode
- Diode

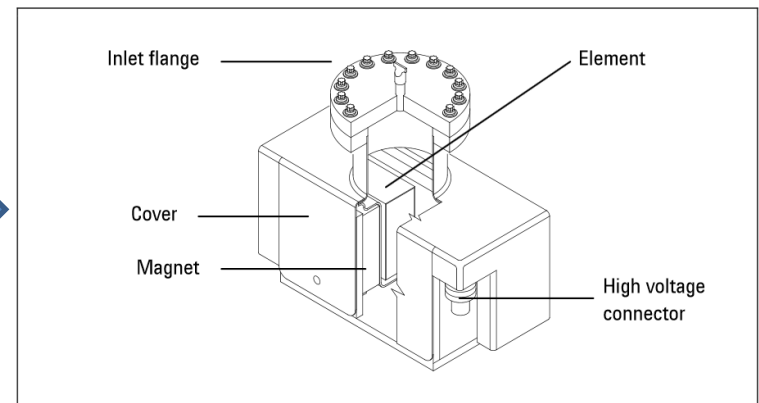
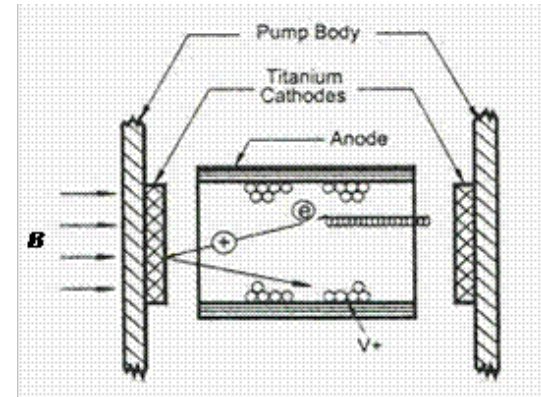

# Ion Pump (2/2)

The ion pump is composed of the following components:

1. a parallel array of short stainless steel tubes (anode)
2. two titanium plates (cathodes) which are spaced a short distance from the open ends of the tubes
3. and a strong magnetic field parallel to the tubes' axes.

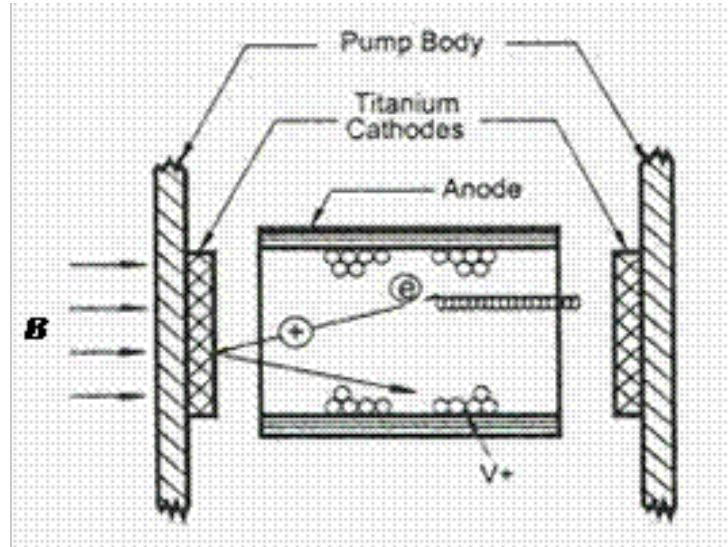

High voltage ( $<10\text{kV}$ ) is applied between the anode and cathode. Electrons from the plates are generated by cold cathode emission and are accelerated toward the anode but are caused to oscillate along a helical trajectory in the anode space by the magnetic field,  $B$ .

When inert gases are ionized, they are accelerated toward the cathode. Upon impact, they may penetrate several atomic layers and become trapped within the cathode lattice structure. They may also reflect as energetic neutrals and become embedded and trapped in the pump surfaces that see little or no sputtering such as the anode surfaces.

In summary, the pumping efficiency depends on the electron “cloud” density (which determines the number of ions produced) and on the sputtering yield (which determines the quantity of active getter material produced).

The electron cloud density mainly depends on the Penning cell geometry and on the electric and magnetic field strengths.

Ion pumps generally have very fast pumping speeds for reactive gases but poorer pumping for noble gases.

# Getter Pump

## Evaporable Getters

The active Ti surface is obtained under vacuum with subsequent depositions of a metal film of Ti in the system



TSP

The titanium is heated to the sublimation temperature (about 1100 °C).

The gas particles which collide on the layer of titanium are linked via chemisorption.

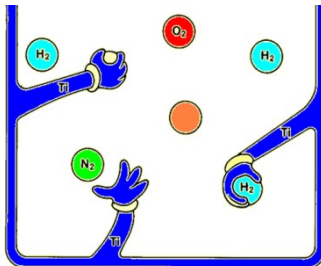

## Non-Evaporable Getters - NEG

Also in this case, a particular material alloy (NEG coating) has the property to absorb the molecules of gas. To activate the surface it is necessary to simply heat it at 250-300 C.

### Main Getter Elements are:

Barium, zirconium, tantalum, molybdenum, vanadium, titanium, niobium

**NEG Coating**: i.e. 84% Zr; 16% Al or Zr, Fe, V  
About 0,07 mm

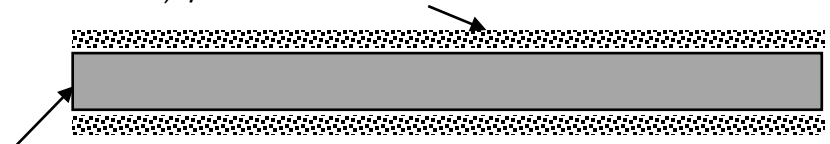

**Support**: plated iron or nickel, thickness 0,2 mm



# Thermal Conductivity Vacuum Gauge (Pirani)

**This measurement principle utilizes the thermal conductivity of gases for the purpose of pressure measure in the range from  $10^{-4}$  mbar to atmospheric pressure.**

Two platinum filaments are used as two arms of a Wheatstone bridge:

⇒ The filament in the reference tube is immersed in a gas at a fixed pressure in the high vacuum regime;

⇒ The measurement filament is exposed to the vacuum system environment.

Both filaments are heated to a constant temperature by the current through the bridge.

**When gas molecules in the vacuum system hit the filament, thermal energy is conducted away. This loss in thermal energy is detected and replaced by the feedback circuit to the power supply. The amount of electrical current needed to restore the temperature of the filament is then converted to a pressure readout.**

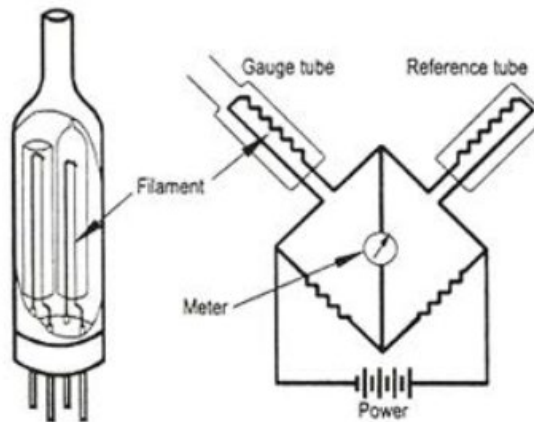

**The resistance change define the vacuum pressure**

## Advantages:

- ✓ Stable measurements within a wide temperature range
- ✓ Highly resistant to overpressure

Pirani gauges have inherent errors because the thermal conductivity and viscosity for each specific gas is different and varies non-linearly with pressure. **They are therefore not used for measuring absolute pressures.**



# Vacuum Gauge based on Ionization Probability

## Penning gauge: more stable, less precise

- cold-cathode gauge
- 2 electrodes: anode, cathode+ permanent magnetic field
- invented 1937 by Penning
- precursor of sputter-ion pump
- nonlinear dependence

Here the pressure is measured through a gas discharge in the gauge head where the gas discharge is obtained by applying a high voltage.

The pressure range from  $10^{-4}$  to  $1 \times 10^{-9}$  mbar.

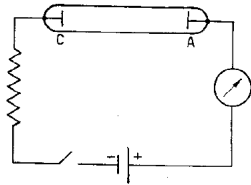
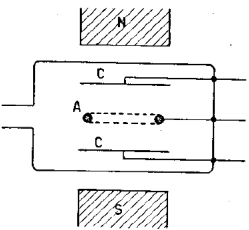

### Advantages:

- ✓ is rugged enough
- ✓ is resistant to sudden variations of pressure.
- ✓ Low tendency for contamination (also during argon operation) due to high voltage reduction after ignition of the plasma and due to the titanium cathodes

## Bayard-Alpert gauge: less stable, more precise

- hot-cathode gauge,
- 3 electrodes: filament, collector, grid
- invented 1950, revolution in vacuum technology linear dependence

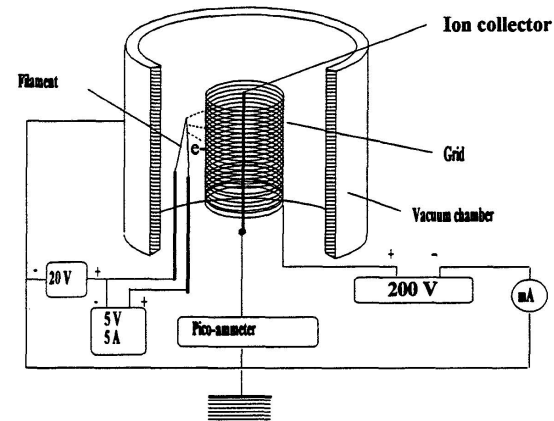

- Molecules are ionized and collected.
- Pressure reading is determined by the electronics from the collector current.

### Advantages:

- ✓ The sensitivity of the device is more different for each gas;
- ✓ is necessary to degas the head of measure to avoid outgassing



# Helium Leak Detectors

What is a Helium Mass Spectrometer Leak Detector?

1. It is a **Helium-specific partial pressure analyzer**
2. It detects Helium applied as a tracer or probe gas
3. It consists of:
  - **the mass spectrometer tube tuned on He**
  - its own vacuum system capable of  $10^{-5}$  mbar in the spectrometer tube
  - a sensitive and stable amplifier valves, and auxiliary pumps for interfacing to vacuum system
  - a display for monitoring leak rate
  - Sensitivity is  $10^{-10}$  mbar or better

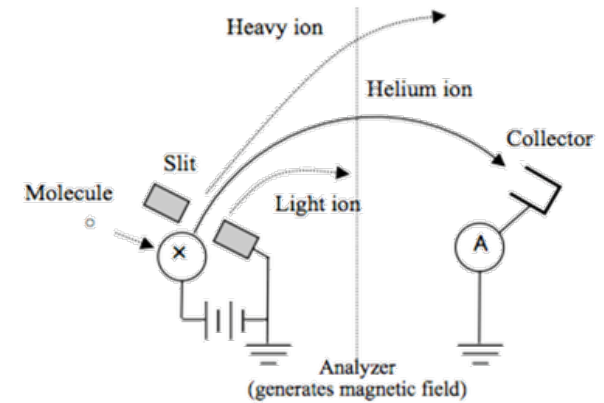

⇒ **A helium leak detector permits the localization of leaks and the quantitative determination of the leak rate, i.e. the gas flow through the leak.** Such a leak detector is therefore a *helium flow meter*.

In practice the leak detector performs this task by **firstly evacuating the part** which is to be tested, so that gas from the outside may enter through an existing leak due to the pressure difference present. If there is a leak, **helium can enter in the system** from the leak (for example by using a spray gun). This helium flows into the leak detector and is detected.

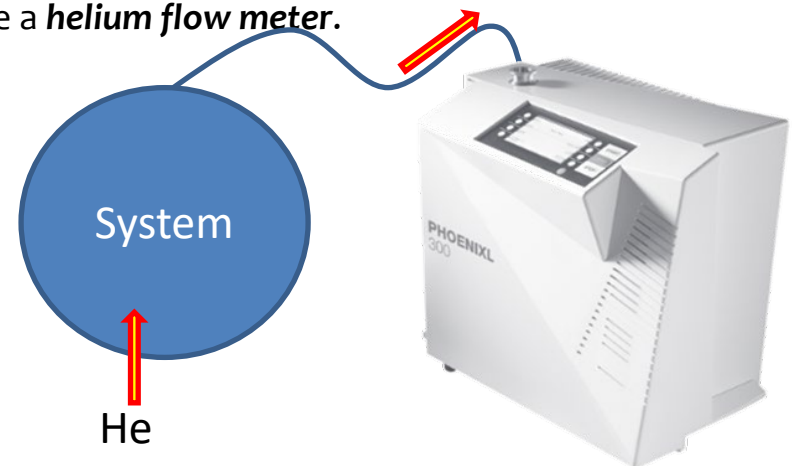

# VACUUM SYSTEM DESIGN

1. Vacuum Materials
2. Clean Process
3. Laboratory Experience

# *Vacuum Materials*

## **QUESTIONS TO ASK YOURSELF WHEN CHOOSING VACUUM MATERIALS**

1. Have I added up the total gas loads from all the materials?
2. Have I defined each material well enough?
3. What would happen to the total gas load if I substituted for any single material?
4. Does any single material's gas load dominate over the others?
5. Have I compromised too far or too many times?
6. Am I really sure that I've looked at every material?
7. Have I made any mistakes?

# Choice of structural vacuum chamber material

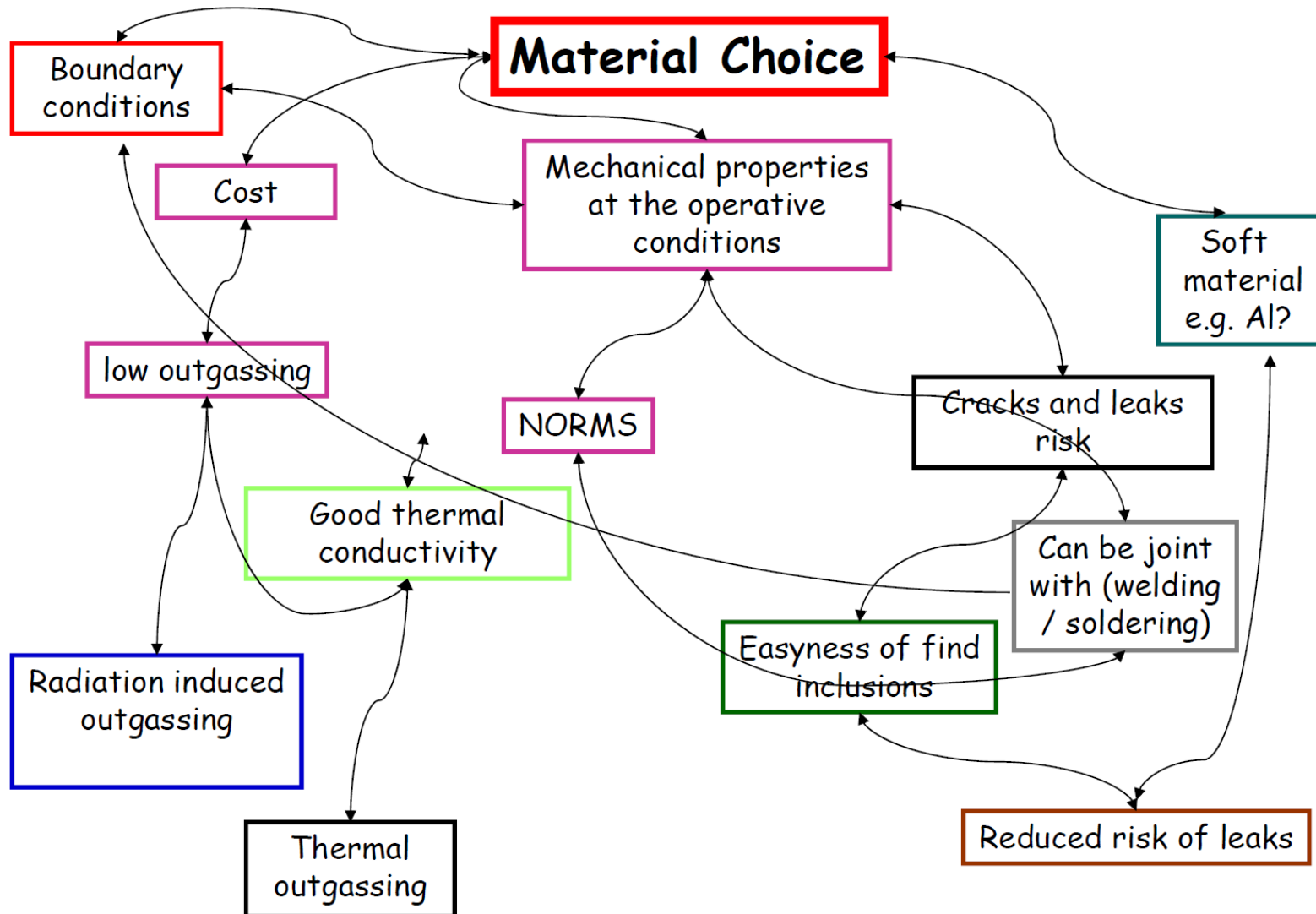

# Materials to use: Metals

## STAINLESS STEEL

- Most common choice in HV and UHV systems
- **304** – common,
- **304L** – Low carbon variant of 304 especially in UHV systems
- **321** – for when low magnetic permeability is required

**BUT...** Avoid 303 grade – contains sulphur and tends to outgas



## COPPER (Oxygen-free) C10100 & C10200

- 'Oxygen-free' type is widely used
- Easy to machine
- Impermeable to hydrogen and helium
- Low sensitivity to water vapour



## TUNGSTEN

- Can be used at high temperatures
- Can be used for filaments

**BUT...** Becomes brittle when work-hardened



## ALUMINIUM & AL ALLOYS

- Low outgassing
- Easy to machine
- Low weight and lower cost

**BUT...** Some alloys contain a high proportion of Zinc ; Must NOT be anodised; Poor strength at high temperatures ; Not easy to weld

# Materials to use: Ceramics

## PORCELAIN AND ALUMINA

- Excellent electrical insulation
- Non-porous if fully vitrified
- Low coefficient of thermal expansion – usable to 1500°C

## BOROSILICATE GLASS

- Used for viewports
- Can be machined and joined with metals
- Low coefficient of thermal expansion – resistant to thermal shock



# Materials to use: Polymers

## PTFE-TEFLON

- Good electrical insulator
- Tolerant to high temperatures
- Low outgassing



*BUT... Cannot be used as a barrier between vacuum and atmosphere as it is permeable to gases*

## KAPTON

- Good electrical insulator
- Tolerant to high temperatures
- Very low outgassing
- Available in tape and film form



## PEEK – Polyether ether ketone

- Excellent mechanical & chemical resistance
- Suitable for UHV applications
- Very low outgassing

*BUT... Has a melting point of 343°C*



## VITON

- Used for demountable seals ('O' rings etc.)
- Can also be used as a seating face in valves
- Good electrical insulator
- Good chemical resistance
- Bakeable to 200°C





# Materials To Avoid because of the high vapor pressure

## CADMIUM

Often present in the form of plating (fasteners etc.) or in some brazing alloys



## ZINC

Is a problem in high vacuum and high temperatures. Present in some alloys like brass (some electrical fittings)



## MAGNESIUM

- Low melting point (650°C at atmosphere). Contains free hydrogen gas

## PVC

- Often found in wire insulation, dust caps etc.

## POLYMERS

- Many have an affinity to water
- Especially plastic tapes. Mould release residue can be an issue too. Polymers may generate a static charge attracting dust
- Nylon has a high outgassing rate

# Bake-out

To achieve pressures in the ultra-high vacuum range ( $<10^{-8}$  hPa) the following conditions must be met:

- The base pressure of the vacuum pump should be a factor of 10 lower than the required ultimate pressure.
- The materials used for the vacuum chamber and components must be optimized for minimum outgassing and have an appropriate surface finish grade.
- Metallic seals (e. g. CF flange connections or Helicoflex seals for ISO flange standards) should be used.
- **Clean work is a must for ultra-high vacuum**, i. e. all parts must be thoroughly cleaned before installation and must be installed with grease-free gloves.
- The equipment and high vacuum pump must be baked out.
- Leaks must be avoided and eliminated prior to activating the heater.
- A helium leak detectors or mass spectrometer must be used for this purpose.

Bake-out significantly increases desorption and diffusion rates, and this produces significantly shorter pumping times. As one of the last steps in the manufacturing process, chambers for UHV use can be annealed at temperatures of up to 900 °C.

N.B: If stainless steel vessels with an appropriate surface finish grade and metal seals are used, bake-out temperatures of 120°C and heating times of approximately 48 hours are sufficient for advancing into the pressure range of  $10^{-10}$  mbar.

# UHV pump down and bake out

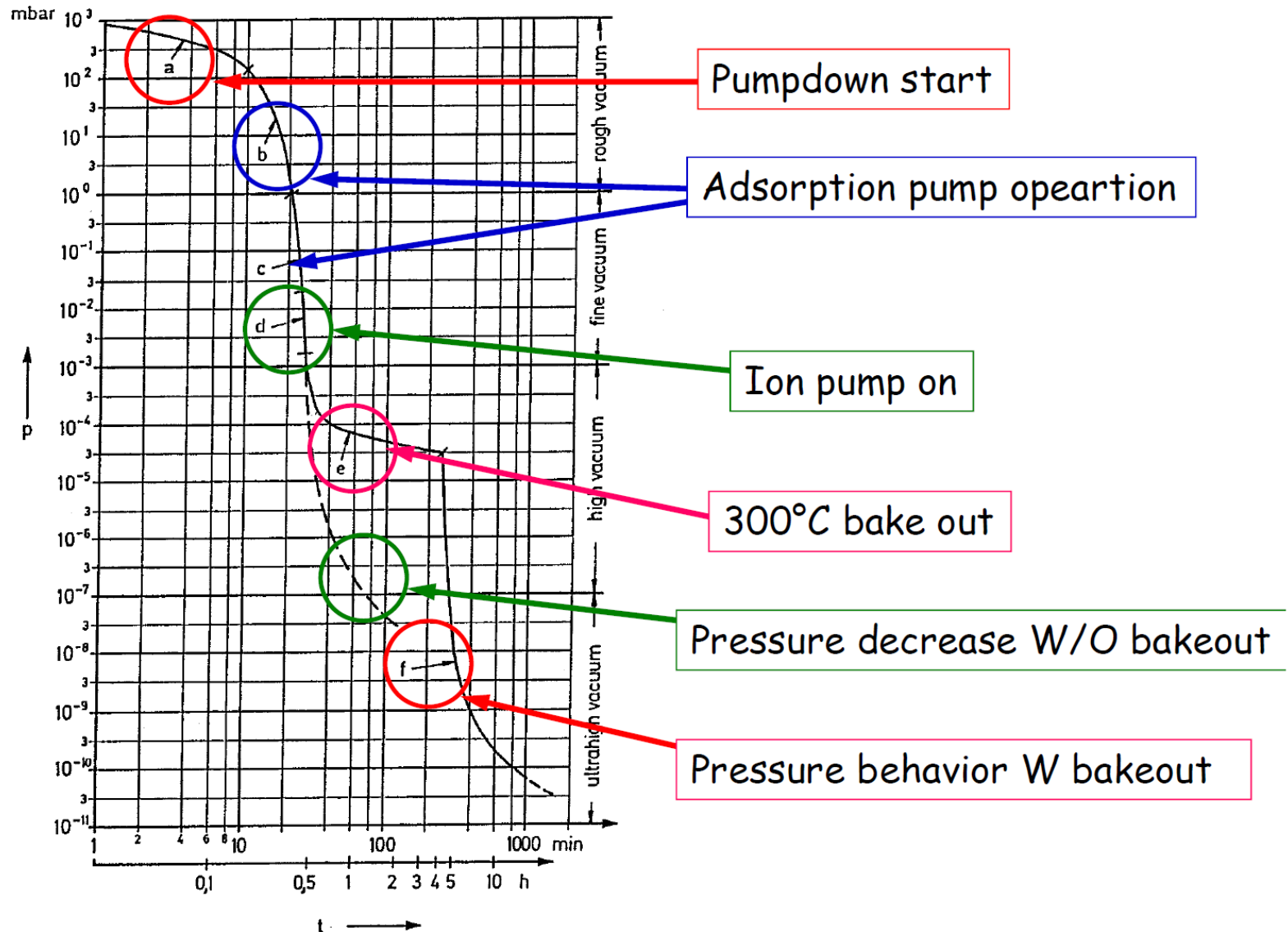



**ENDING SLIDE**

**THANK YOU FOR YOUR ATTENTION!**