

# Magnetic Measurements

Accelerator Physics PhD – Università di Roma “La Sapienza”

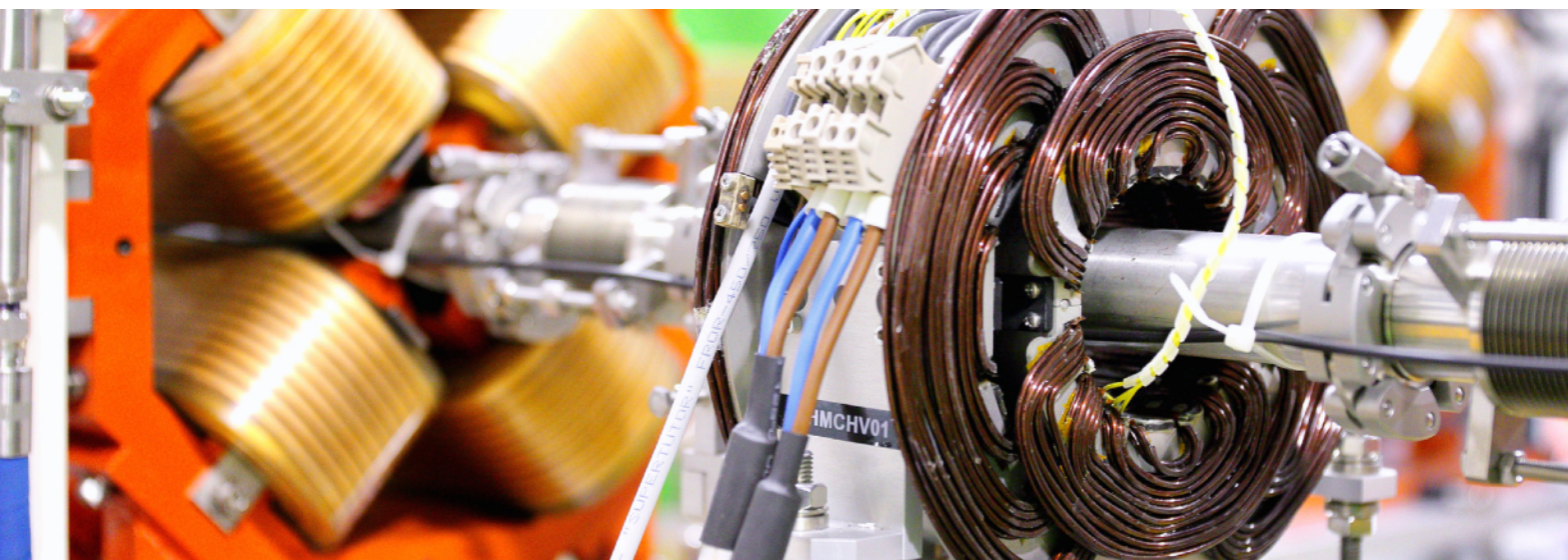

Istituto Nazionale di Fisica Nucleare – Laboratori Nazionali di Frascati

Ilaria Balossino, Lucia Sabbatini, Andrea Selce, Antonio Trigilio, Alessandro Vannozzi

Divisione Acceleratori - Servizio Ingegneria Elettrotecnica

# References



- Transverse Beam Dynamics (A. Latina) lectures of JUAS 2016 Course 1
- Magnets Course (T. Zickler) JUAS 2016 Course 2
- Magnets Course (D. Tommasini) JUAS 2016 Course 2
- Superconducting Magnets (T. Wilson) JUAS 2015 Course 2
- CERN Accelerator School (CAS) – Magnets 2006 (CERN–2010–004)

# Outline

- Recall: Maxwell equations
- What are the Magnets Tasks in Particle Accelerators
- Magnet Types
- Air Dominated vs Iron Dominated Magnets
- Iron Dominated Magnets Iron Yoke
- Field Description in Air Gap
- Magnetic Length
- Relevant Magnetic Parameters in Magnets
- Magnetic Field Quality
- Permanent Magnets Overview
- Magnetic Measurements

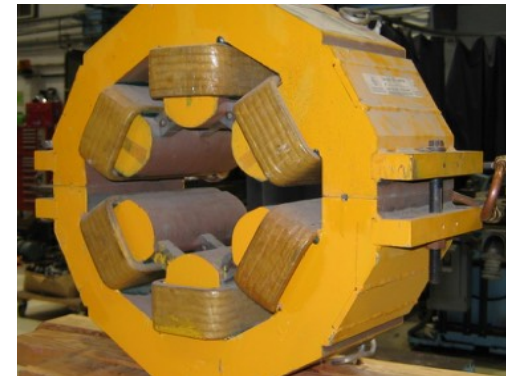
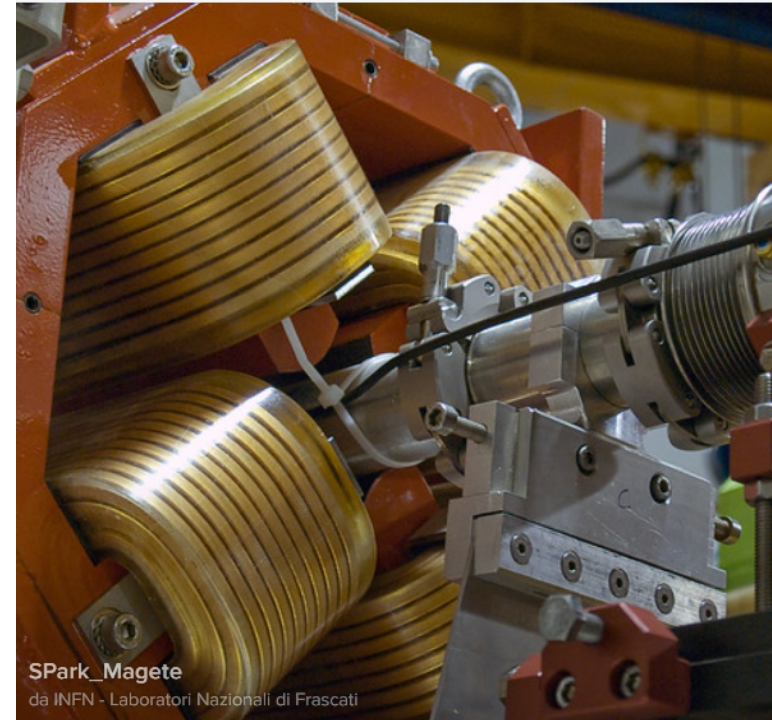



# Maxwell's equations

In 1873, [Maxwell](#) published "Treatise on Electricity and Magnetism" in which he summarized the discoveries of Coulomb, Oersted, Ampere, Faraday, et al. in four mathematical equations:

Gauss' law for electricity:

$$\nabla \cdot \vec{E} = \frac{\rho}{\epsilon_0}$$

Gauss' law of flux conservation:

$$\nabla \cdot \vec{B} = 0$$

Faraday's law of induction:

$$\nabla \times \vec{E} = -\frac{\partial \vec{B}}{\partial t}$$

Ampere's circuital law:

$$\nabla \times \vec{B} = \mu_0 \vec{J} + \mu_0 \epsilon_0 \frac{\partial \vec{E}}{\partial t}$$

$$\oint_{\partial V} \vec{E} \cdot d\vec{A} = \frac{q}{\epsilon_0}$$

$$\oint_{\partial V} \vec{B} \cdot d\vec{A} = 0$$

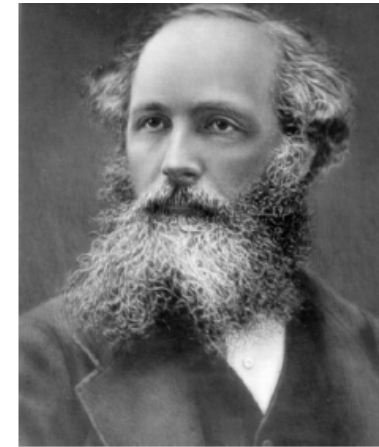

$$\oint_{\partial A} \vec{E} \cdot d\vec{s} = -\frac{d\Phi}{dt} = -\frac{d}{dt} \int_A \vec{B} \cdot d\vec{A}$$

$$\oint_{\partial A} \vec{B} \cdot d\vec{s} = \int_A \mu_0 \vec{J} \cdot d\vec{A} + \frac{d}{dt} \int_A \mu_0 \epsilon_0 \vec{E} \cdot d\vec{A}$$



# What are the tasks of magnets in Particle Accelerators?

They generate a magnetic field ( $B$ ) that interacts with the particle beam by means of **Lorentz Force**:

$$\vec{F} = q(\vec{E} + \vec{v} \times \vec{B})$$

At each application of the Lorentz force, the particles experience a transverse “kick” in a defined direction. In order to keep the beam on a trajectory (or orbit) while avoiding particle spread in the vacuum pipe, several kicks (**magnets!**) are needed along their path in the accelerator.

Remember the 1d harmonic oscillator:  $F = -k x$

*Circular Accelerator*

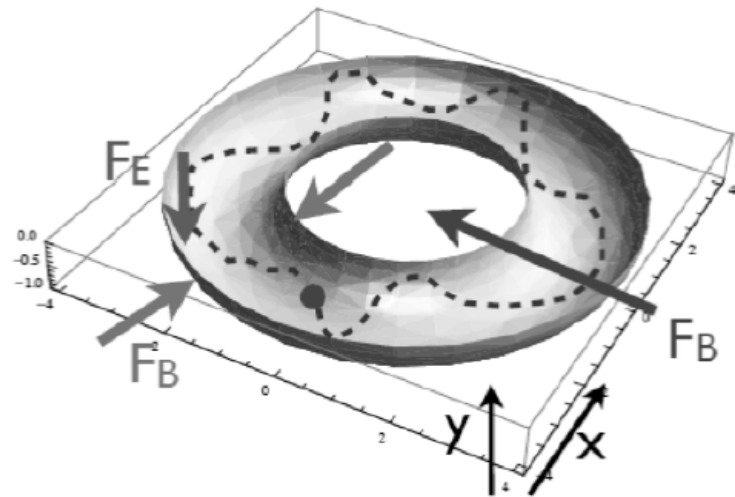

*Linear Accelerator*

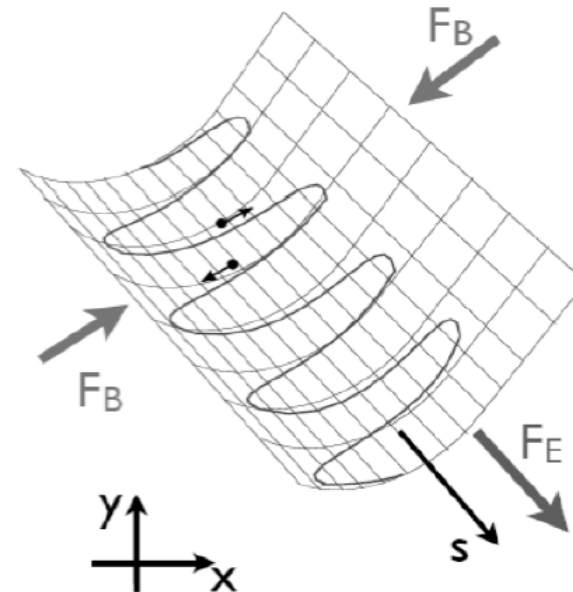

# What are the tasks of magnets in Particle Accelerators?

The main functions of the magnets are:

- **Guide** the beam to keep it on an orbit (circular) or a trajectory (linac) → **Dipoles and Steerers**
- **Focus** the beam (like an optic lens) → **Quadrupoles and solenoids**
- Other corrections → Sextupoles, Octupoles, etc.

## DIPOLES: BEAM DEFLECTION

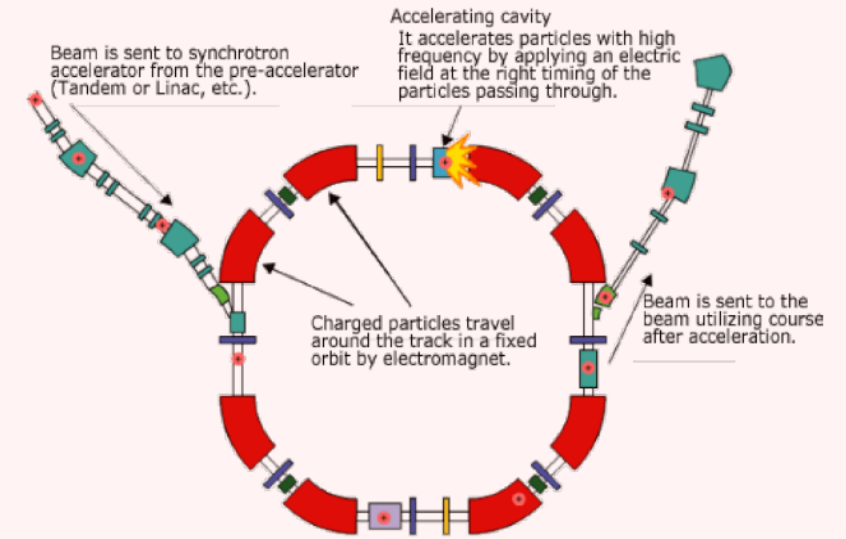
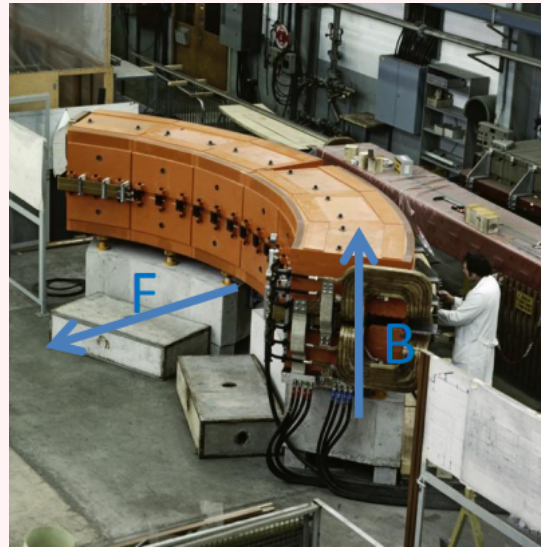
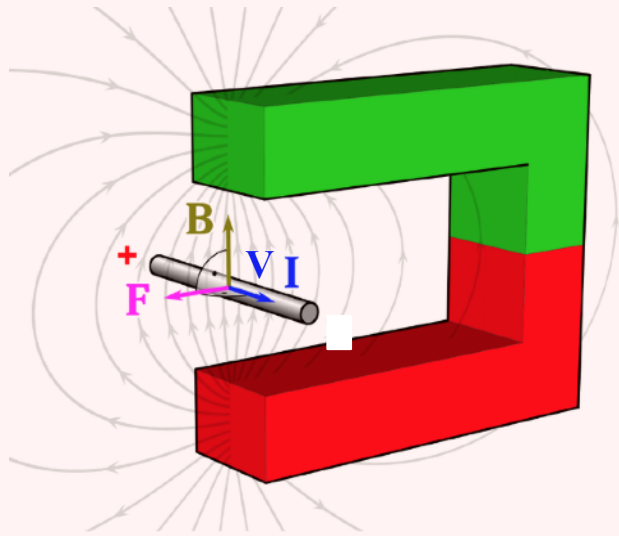

# What are the tasks of magnets in Particle Accelerators?

## QUADRUPOLES: BEAM FOCUSING

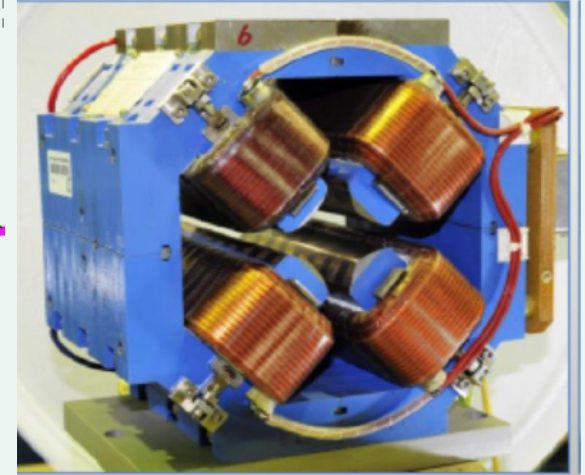
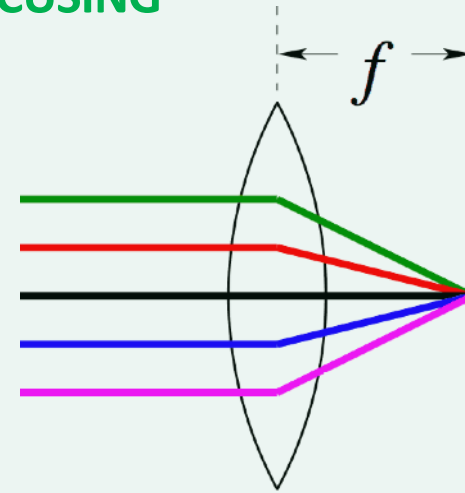
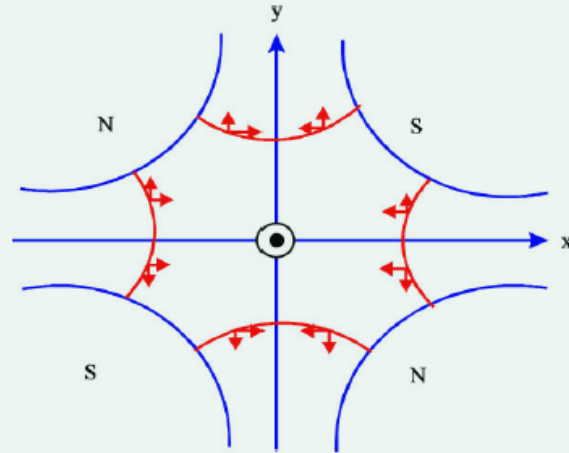
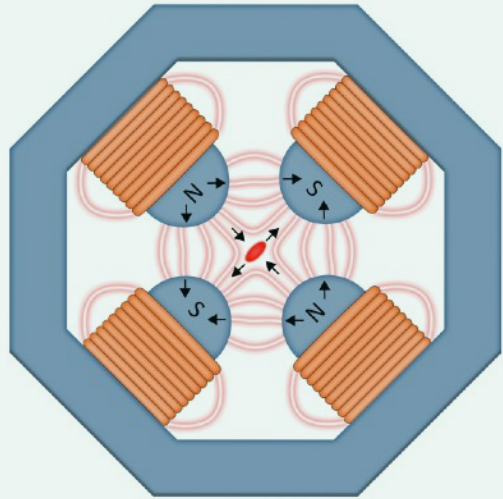

## SOLENOIDS: BEAM FOCUSING

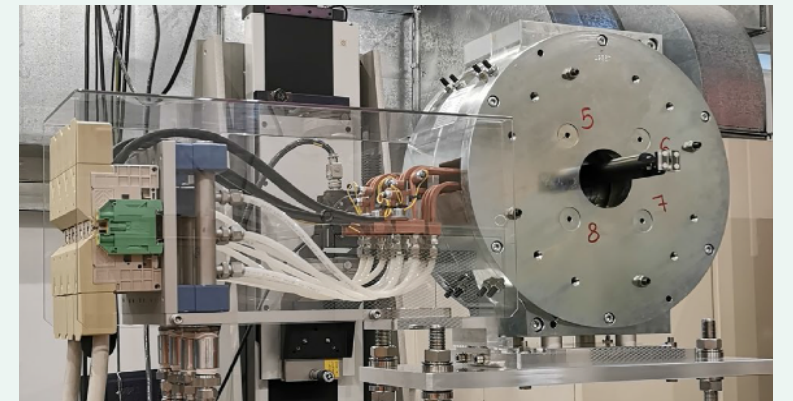
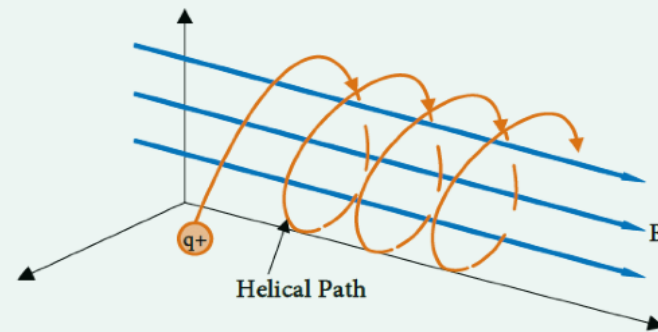
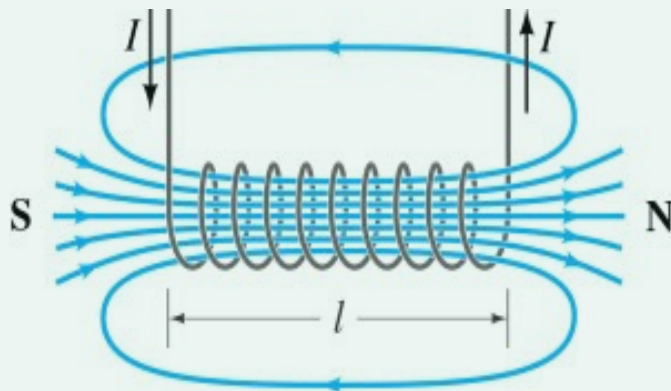



# Dipole Magnets – The Magnetic Guide

$$\left. \begin{array}{l}
 \text{Lorentz force } F_L = qvB \\
 \text{Centrifugal force } F_{\text{centr}} = \frac{\gamma m_0 v^2}{\rho} \\
 \frac{\gamma m_0 v^2}{\rho} = qvB
 \end{array} \right\} \begin{array}{l}
 P = m_0 \gamma v = mv \text{ "momentum"} \\
 \frac{P}{q} = B\rho \\
 B\rho = \text{"beam rigidity"}
 \end{array}$$

$$\frac{1}{\rho [m]} \approx 0.3 \frac{B [T]}{P [\text{GeV}/c]}$$

- The ratio of  $p$  to  $q$  describes the **'stiffness'** of a beam; it can be considered a measure of how much angular deflection occurs when a particle travels through a given magnetic field.
- In a specific magnetic field, particles with greater momentum experience less bending as they travel through the field. Conversely, particles with a higher charge experience more bending in a given magnetic field.

# Quadrupole Magnets - The focusing force

Quadrupole magnets are required to keep the trajectories in vicinity of the ideal orbit

They exert a linearly increasing Lorentz force, thru a linearly increasing magnetic field:

$$\begin{aligned} B_x = gy &\Rightarrow F_x = -qv_z gx \\ B_y = gx &\Rightarrow F_y = qv_z gy \end{aligned}$$

Gradient of a quadrupole magnet:

$$g = \frac{2\mu_0 n l}{r^2} \left[ \frac{T}{m} \right] = \frac{B_{\text{poles}}}{r_{\text{aperture}}} \left[ \frac{T}{m} \right]$$

- ▶ LHC main quadrupole magnets:  
 $g \approx 25 \dots 235 \text{ T/m}$

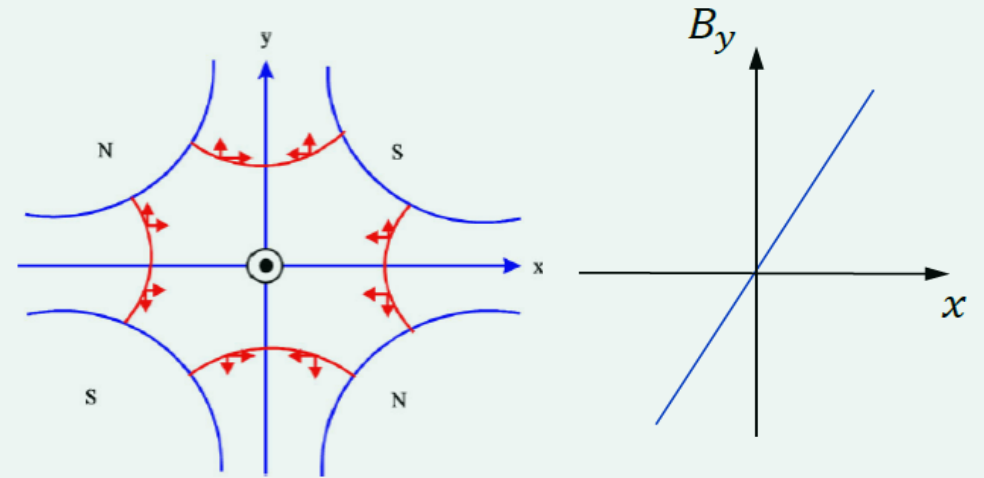

*the arrows show the force exerted on a particle*

Divide by  $p/q$  to find the normalised focusing strength,  $k$ :

$$k = \frac{g}{P/q} [m^{-2}]; \Rightarrow g = \left[ \frac{T}{m} \right]; \quad q = [e]; \quad \frac{P}{q} = \left[ \frac{\text{GeV}}{c \cdot e} \right] = \left[ \frac{GV}{c} \right] = [T \cdot m]$$

A simple rule:  $k [m^{-2}] \approx 0.3 \frac{g [T/m]}{P/q [GeV/c/e]}$

# Magnet Types

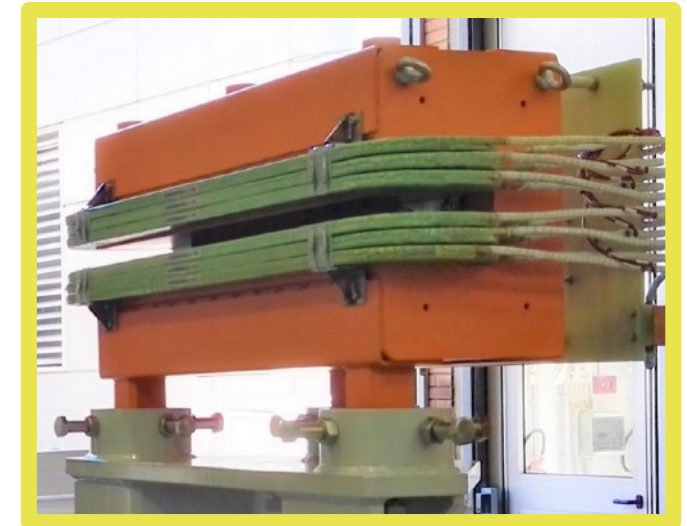
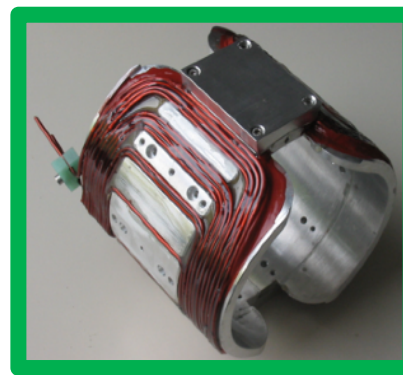
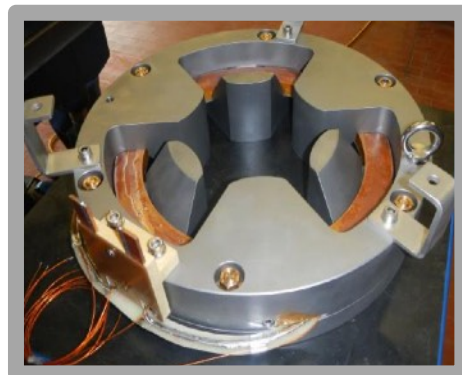
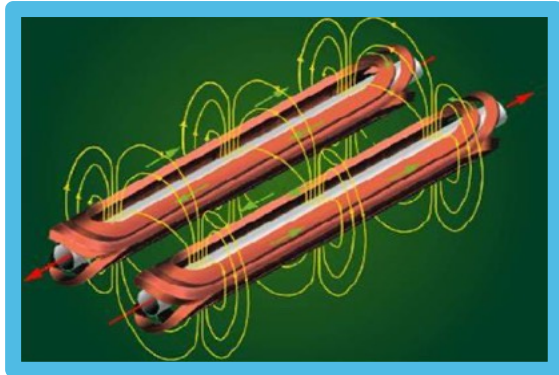
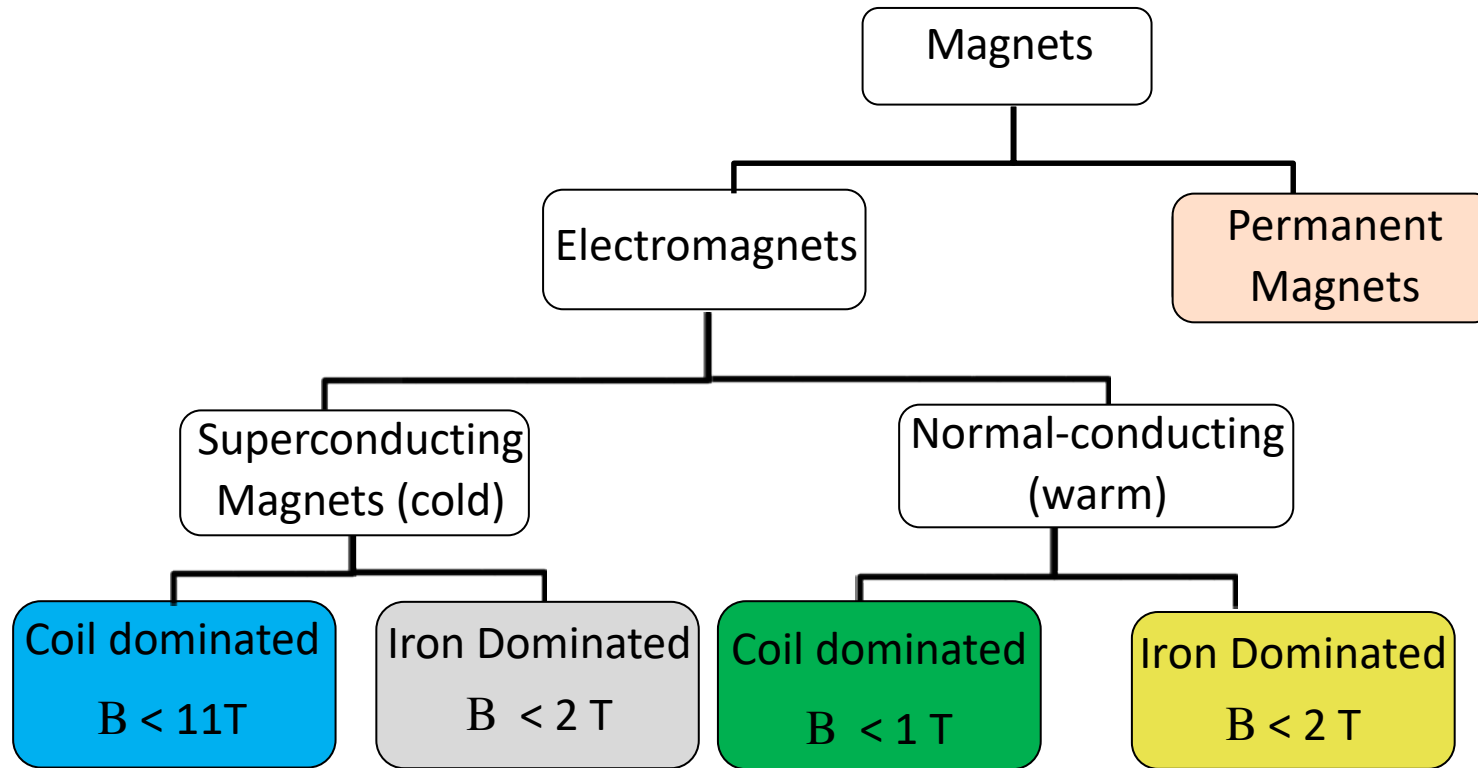



# Air Dominated vs Iron Dominated Electromagnets

- All particle accelerator magnets contain an air region (**air gap**) between the poles through which the beam passes and experiences the magnetic force.
- In electromagnets, the magnetic field is generated by a current flowing through a coil made of electrical conductor materials.
- The flux density lines have a closed path that could include:
  - Only air → **Coil dominated magnet**
  - Air + Iron → **Iron dominated magnet**
- Applying Ampère's law to an iron-dominated magnet (i.e., dipole), we observe a strict correlation between current and magnetic field. The majority of the **magnetizing force** ( $NI$ ) is required to establish flux density within the air gap, where  $\mu_R=1$  (if Iron not saturated →  $B_{iron} < 1.8T$ )

Ampere's law  $\oint \vec{H} \cdot d\vec{l} = NI$  and  $\vec{B} = \mu\vec{H}$

**Iron Dominated**

leads to 
$$NI = \oint \frac{\vec{B}}{\mu} \cdot d\vec{l} = \int_{gap} \frac{\vec{B}}{\mu_{air}} \cdot d\vec{l} + \int_{yoke} \frac{\vec{B}}{\mu_{iron}} \cdot d\vec{l} = \frac{Bh}{\mu_{air}} + \frac{B\lambda}{\mu_{iron}}$$

assuming, that  $B$  is constant along the path.

If the iron is not saturated: 
$$\frac{h}{\mu_{air}} \gg \frac{\lambda}{\mu_{iron}}$$

then: 
$$NI_{(per\ pole)} \approx \frac{Bh}{2\mu_0}$$

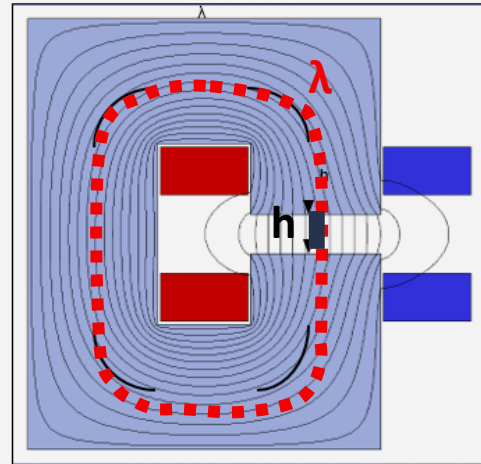

$$h \ll \lambda$$

**Coil dominated**

$$NI_{(per\ pole)} = \oint_{\lambda} \vec{H} \cdot d\vec{l} = \frac{\vec{B}\lambda}{2\mu_0}$$

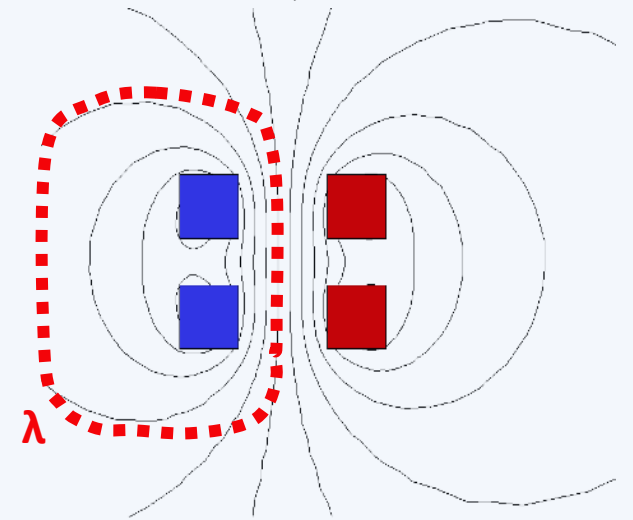

# Filed Description and Field Quality

- The goal of a magnetic designer is to achieve a **desired field distribution (Field Quality)** within a specific region of the air gap, where there is *a high probability* (typically a few standard deviations for the envelope) *of containing the beam envelope* (**Good Field Region**).
- In this region, the field must adhere to certain tolerances.
- The field distribution and, consequently, the field quality are determined by:
  - **The dimensions and shapes of iron poles** for iron-dominated magnets.
  - **The geometric displacement of currents** for coil-dominated magnets.

$$\sigma = \sqrt{\varepsilon\beta + \left(D \frac{\Delta p}{p}\right)^2}$$

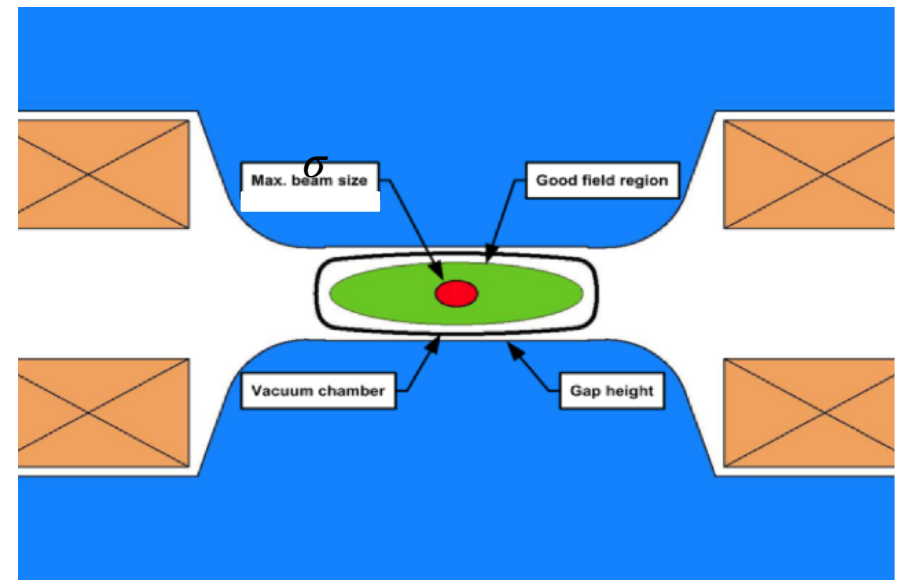

# General Field Description in Air Gap

In the air gap region between poles we assume:

- No currents
- No magnetic materials ( $\mu_r = 1$ )
- $B_z$  is constant (2D case!)



The 2D vector field of  $B$  can be expressed as a series of multipole coefficients  $B_n(r_0)$ ,  $A_n(r_0)$  with  $r_0$  being the reference radius (this is a solution of Maxwell equation inside the air gap) [1] :

$$B_r(r_0, \varphi) = \sum_{n=1}^{\infty} \left(\frac{r}{r_0}\right)^{n-1} [B_n \sin(n\varphi) + A_n \cos(n\varphi)]$$

$$B_\varphi(r_0, \varphi) = \sum_{n=1}^{\infty} \left(\frac{r}{r_0}\right)^{n-1} [B_n \cos(n\varphi) - A_n \sin(n\varphi)]$$

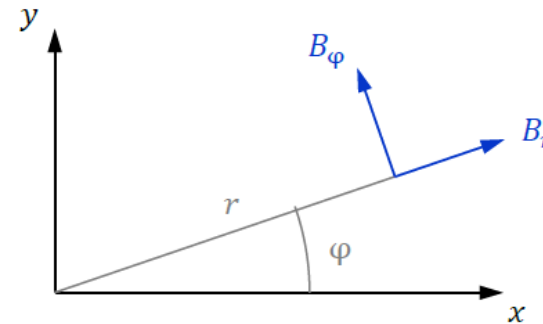

[1] *Maxwell's equations for magnets* - A. Wolski Cern Accelerating School (CAS) CERN-2010-004



# General Field Description in Air Gap

- For simplicity, let's write these series with complex notation, defining a complex variable  $z$ . In this way, we avoid using sine and cosine functions.
- Note that the field distribution is split into two components: **normal** ( $B_n$ ) and **skew** ( $A_n$ )

$$z = x + iy = r e^{i\varphi}$$

$$B_y(z) + iB_x(z) = \sum_{n=1}^{\infty} (B_n + iA_n) \left( \frac{z}{r_0} \right)^{n-1}$$

# General Field Description in Air Gap

$B_1$ : normal dipole

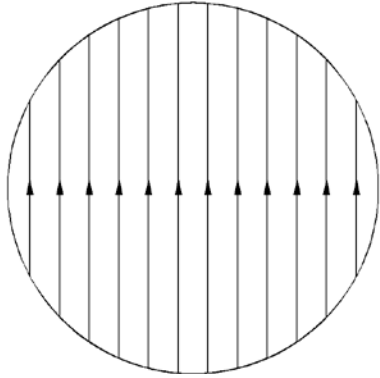

$B_2$ : normal quadrupole

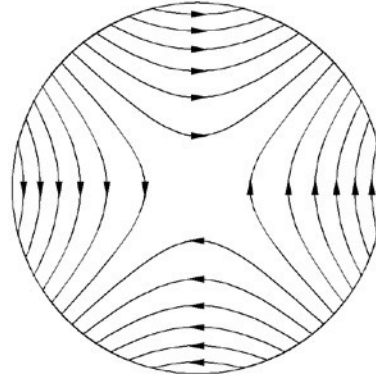

$B_3$ : normal sextupole

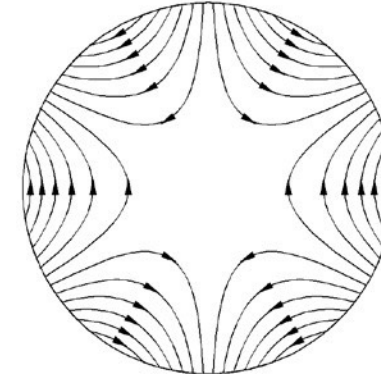

$A_1$ : skew dipole

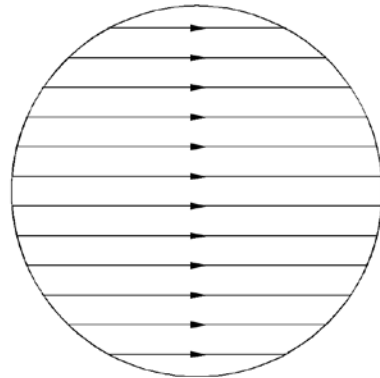

$A_2$ : skew quadrupole

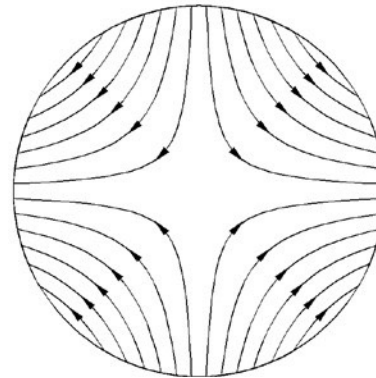

$A_3$ : skew sextupole

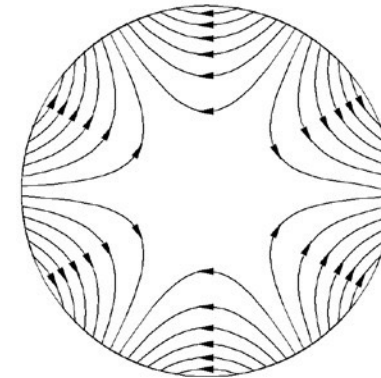

Each multipole term has a corresponding magnet type

# General Field Description in Air Gap

$$B_y(x) = \sum_{n=1}^{\infty} B_n \left(\frac{x}{r_0}\right)^{n-1} = B_1 + B_2 \frac{x}{r_0} + B_3 \frac{x^2}{r_0^2} + \dots$$

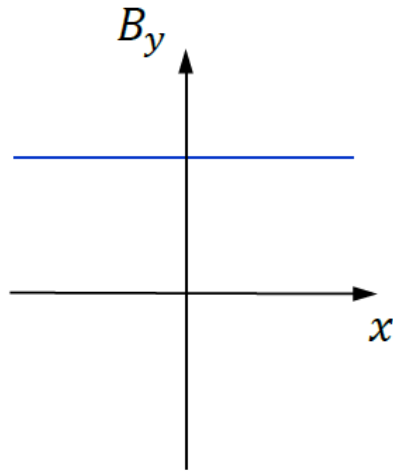

$B_1$ : dipole

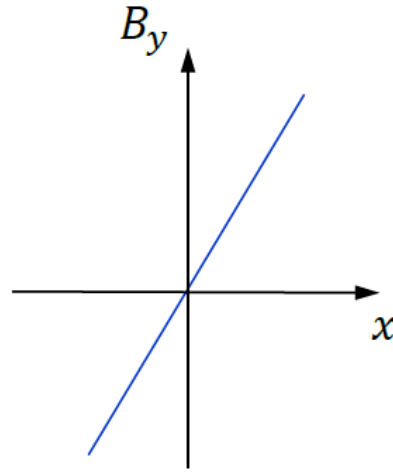

$B_2$ : quadrupole

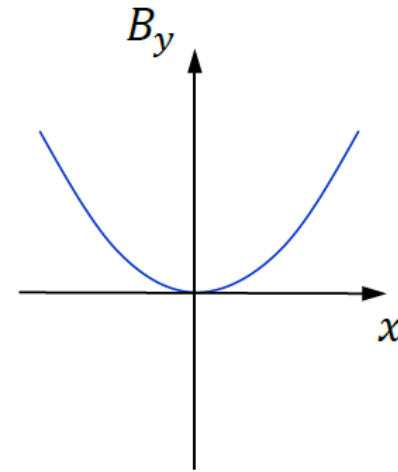

$B_3$ : sextupole

$$G = \frac{B_2}{r_0} = \frac{\partial B_y}{\partial x}$$

The field profile in the horizontal plane follows a polynomial expansion  
The ideal poles for each magnet type are lines of constant scalar potential

# Permanent Magnets Characteristics



- Magneto-motive force ( $NI$ ) generated not by currents but by **permanent magnet blocks**.
- Composed of **sintered rare earths (samarium, cobalt, neodymium, etc.)** magnetized during production with an external magnetic field.
- There is also an iron core to reduce the reluctance of the magnetic circuit (same function as electromagnets).
- In some configurations, it is possible to adjust the magnetic field by modifying the geometry of the magnet (e.g., shifting magnetized blocks).
- There is significant interest for their potential to reduce the energy impact of accelerators (though the issue of rare earths remains).
- Advantages: no energy consumption, no coil cooling required.
- Disadvantages: difficult magnetic field adjustment, magnetization of blocks linked to irradiation and temperature.

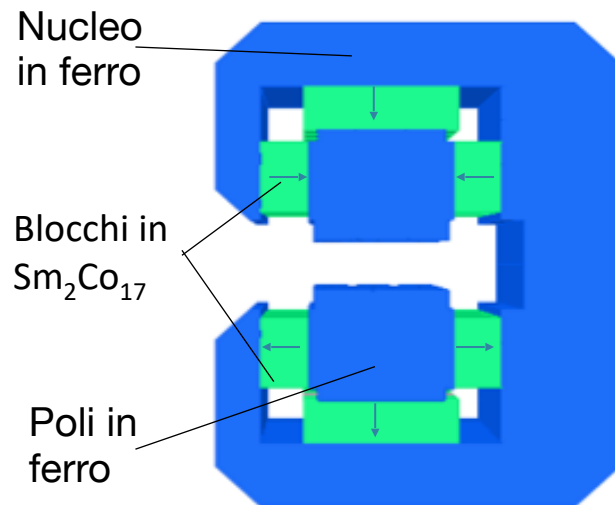



# Halbach Array

Configuration of permanent magnets with periodic magnetic polarization orientation that **maximizes the magnetic field in a specific region of space** (i.e., on one side of the array).

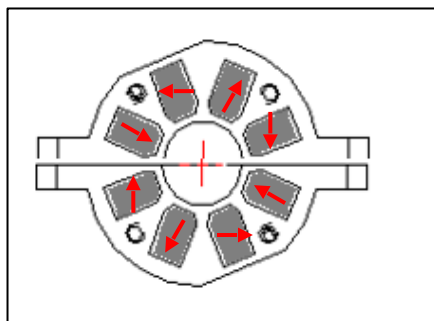
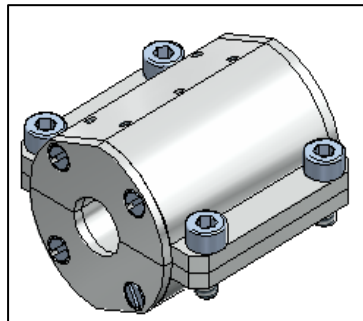
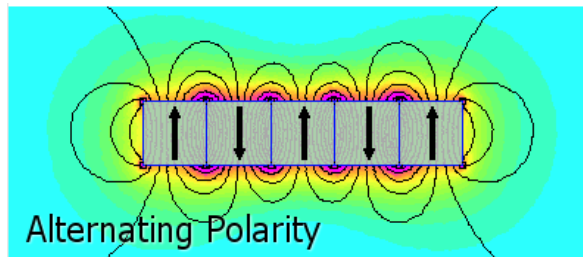
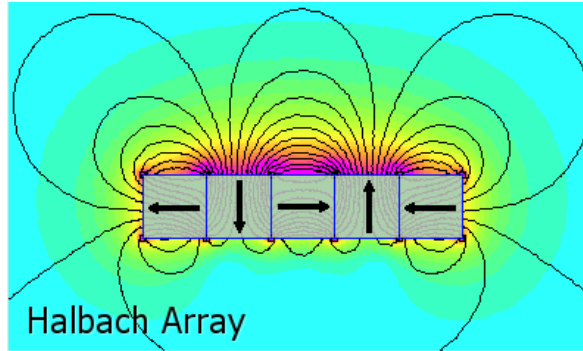

- Developed out of the need to maximize the focusing of permanent magnet **quadrupoles**.
- A typical configuration for particle accelerators is that of a cylinder with a magnetization vector that varies periodically in orientation. Depending on the period, a different **multipole** (i.e., dipole, quadrupole, sextupole, etc.) can be achieved.
- In practice, it is an assembly of various magnetized blocks, each with its own orientation of the magnetization vector.

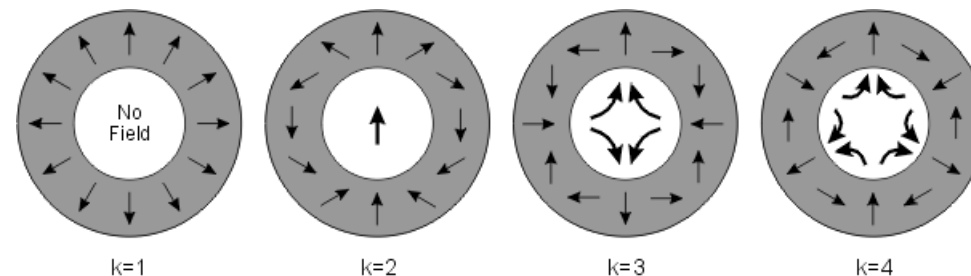

$$M = M_r \left[ \cos\left((k-1)\left(\varphi - \frac{\pi}{2}\right)\right) \hat{\rho} + \sin\left((k-1)\left(\varphi - \frac{\pi}{2}\right)\right) \hat{\varphi} \right]$$

# Magnetic Length

- For all types of magnets, the longitudinal field profile is very similar (for quadrupoles, the off-axis profile).
- It shows two “tails”, which are the stray field regions, and a “flat top”, where the field is almost constant.
- It is possible to define a “magnetic length” (effective length) that is always larger than the actual iron length (mechanical length):

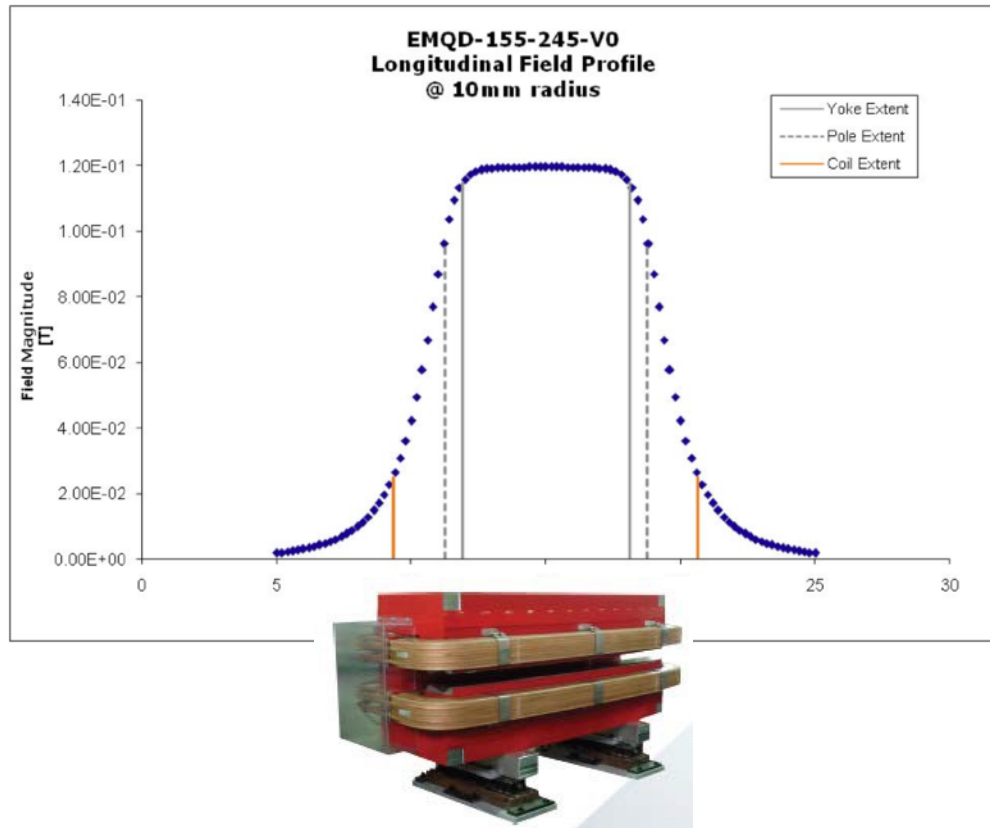

$$L_{mag} = \frac{\int_{-\infty}^{+\infty} B_y(z) dz}{B_0}$$

Dipole:  $l_{mag} \approx l_{iron} + 2hk$

$h$ : magnet gap

$k$ : geometrical factor, typically 0.3÷0.6

Quadrupole:  $l_{mag} \approx l_{iron} + 2rk_2$

$r$ : aperture radius

$k_2$ : geometrical factor, typically ~0.45

# Magnetic Length

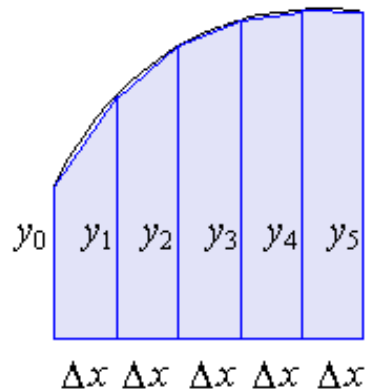
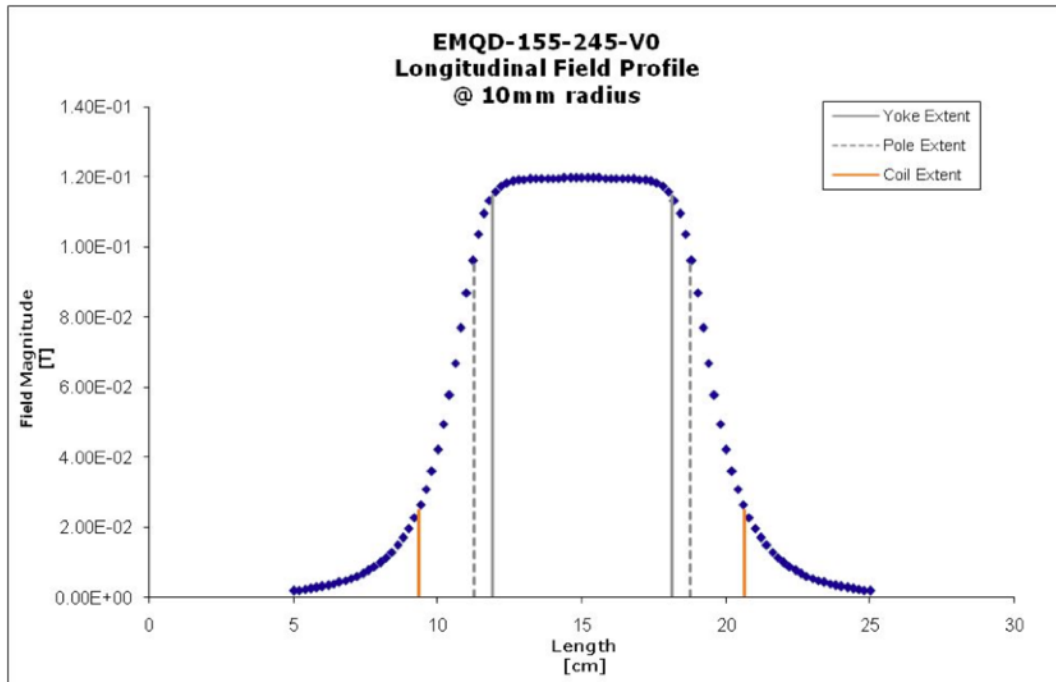

Dipole

$$\text{Int} B = B_{max} \cdot L_{mag} = B \cdot \rho \cdot \theta = \frac{E [MeV]}{300} \cdot \theta$$

Quadrupole

$$\text{Int} G = \int_{-\infty}^{+\infty} \text{Grad}_z(y) dy = G \cdot L_{mag} = \frac{E [MeV]}{300} \cdot K \cdot L_{mag}$$

Trapezoidal rule to evaluate a general integral

$$\int y dx = \frac{\Delta x}{2} (y_1 + 2y_2 + 2y_3 + \dots + 2y_{n-2} + 2y_{n-1} + y_n)$$

# Magnetic Field Quality – Field Uniformity (+ integrated)

Defined as:

- **Field or (integrated field) uniformity**
- Relative field harmonic

A field quality figure of merit is also the relative difference between the central field (for dipoles) or gradient (for quadrupoles) with respect to the field or gradient at another position within the good field region.

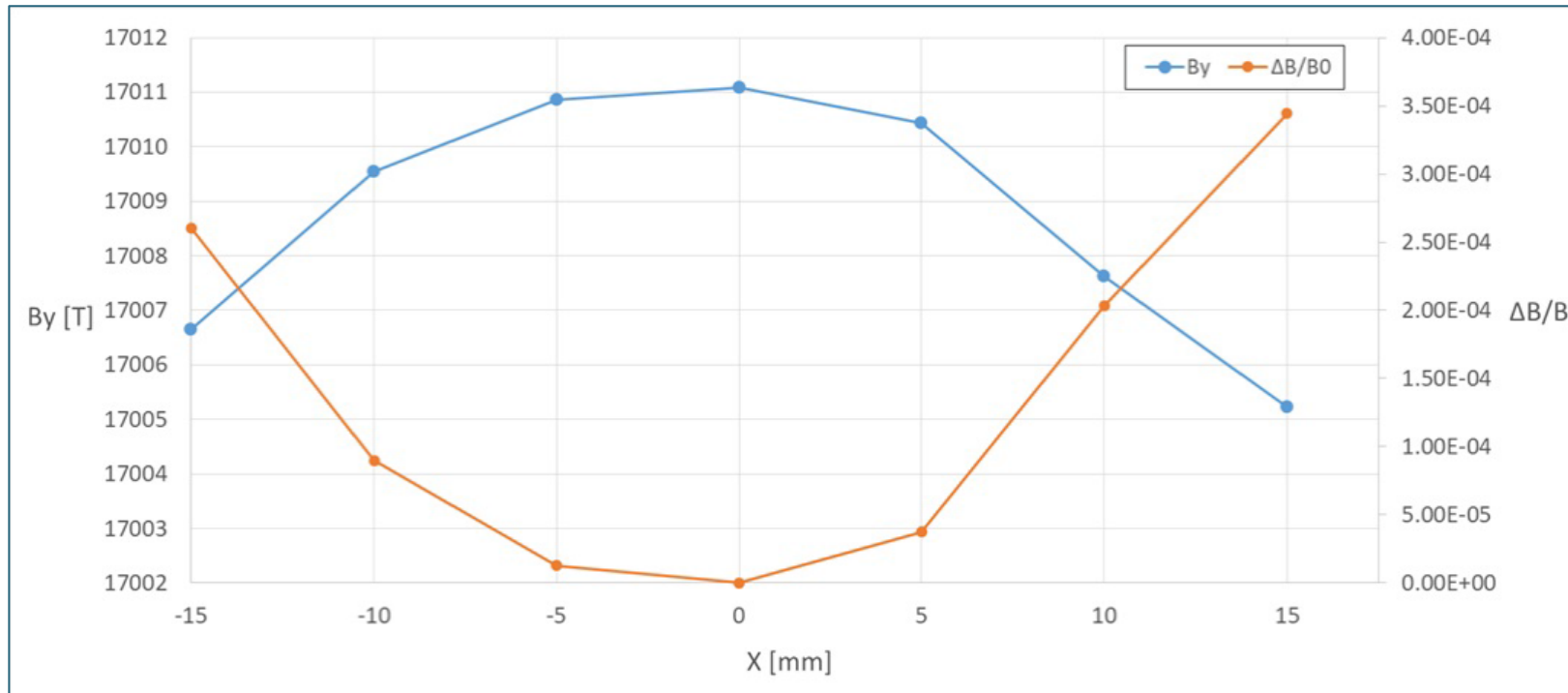

$$\frac{\Delta B}{B_0} = \frac{B(x, y) - B(0,0)}{B(0,0)}$$

Dipoles

$$\frac{\Delta IB}{IB_0} = \frac{IB(x, y) - IB(0,0)}{IB(0,0)}$$

$$\frac{\Delta G}{G_0} = \frac{G(x, y) - G(0,0)}{G(0,0)}$$

Quad

$$\frac{\Delta IG}{IG_0} = \frac{IG(x, y) - IG(0,0)}{IG(0,0)}$$



# Magnetic Field Quality – Field Multiples

Defined as:

- Field or (integrated field) uniformity
- **Relative field harmonic**

$$B_y(z) + iB_x(z) = \sum_{n=1}^{\infty} (B_n + iA_n) \left(\frac{z}{r_0}\right)^{n-1}$$

$$z = x + iy = r e^{i\varphi}$$

$$b_i = \frac{B_i}{B_{ref}} 10^4$$

- When dealing with a real magnet of a specific type that you intend to produce a **particular harmonic** for, you will inevitably encounter **other harmonics**, varying in magnitude.
- We define the "relative field harmonic" as the ratio between a specific field harmonic and the reference field harmonic, expressed in units of  $10^{-4}$  of the main harmonic, at a reference radius  $r_0$ .

- Harmonic analysis performed measuring the field on a close path (usually circular).
- FFT of the signal, defining all the series coefficients that correspond to a multipole.

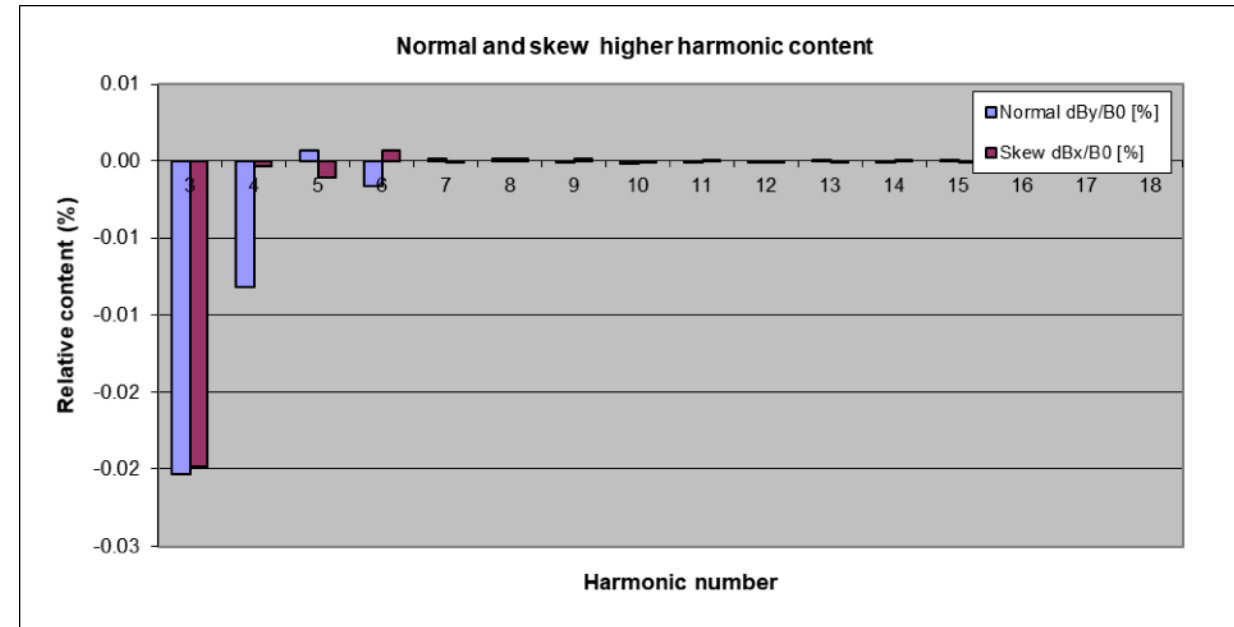

# Magnetic Measurements – Parameters that we want to measure

1. **How is the magnetic distribution in the good field region?**
  - Solenoids: Within an air volume near the solenoid axis.
  - Other Magnets: In the air gap between the poles.
2. Magnets electrical parameters ( $R$  and  $L$ ) and check of turn-to-turn and coil-to-ground insulation.

Two magnetic measurements families:

1. **Point by point** -> In this method, we move a probe sensitive to the magnetic field (a **Hall probe**) with a micrometric precision movement system (a coordinatometer) inside the good field region. This allows us to obtain a 3D field map with the flux density point by point.
2. **Integrated** -> With this method, we use **moving coils**, which can have various geometries, within the magnetic field. As a result of the flux variation in the coil (according to Faraday-Neumann-Lenz law), we observe an induced voltage:

$$e . m . f . = - \frac{d\Phi}{dt}$$

We do not measure the field point by point but a field flux induced in the coil area.

# Point by Point measurement : Hall Probe

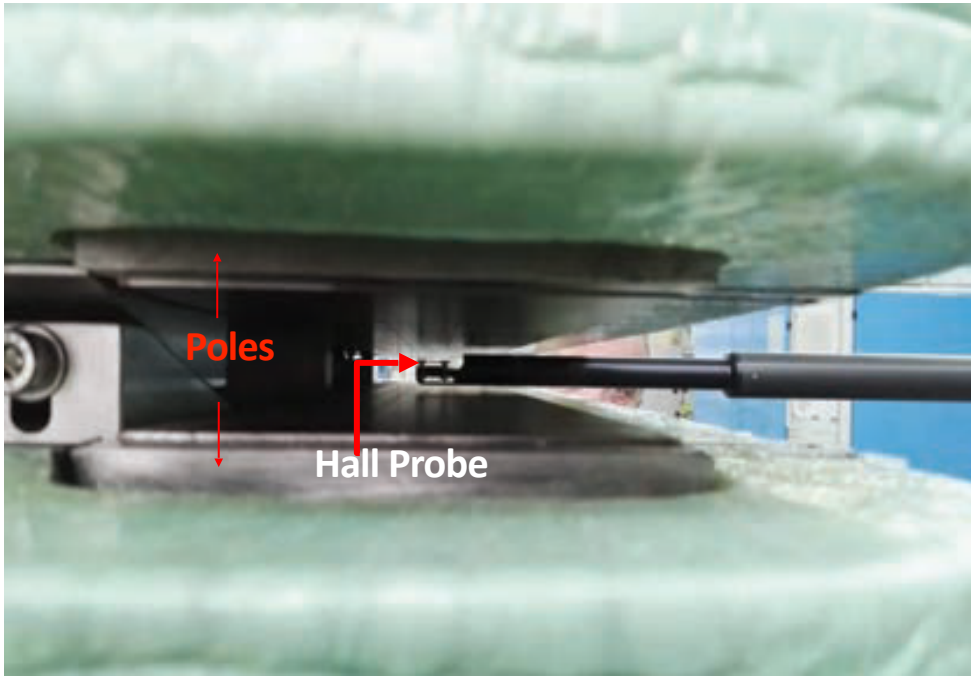

- The Hall probe is a  $B \rightarrow V$  active transducer.
- By reading the voltage generated by the Hall effect, we can define the magnetic field thanks to calibration.
- The high-precision coordinatometer allows the Hall probe to be moved in any desired position.

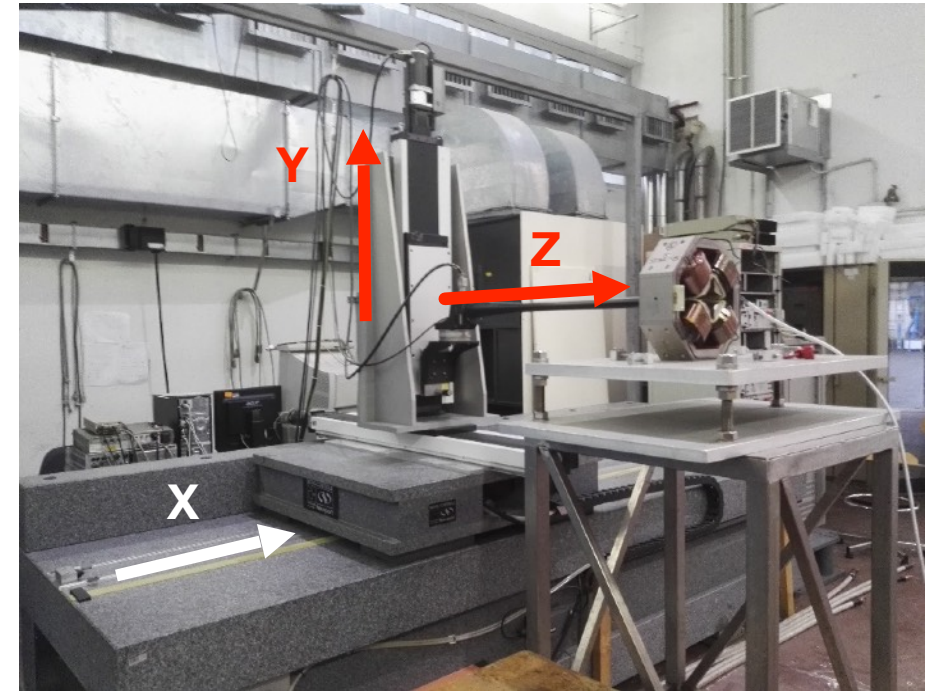
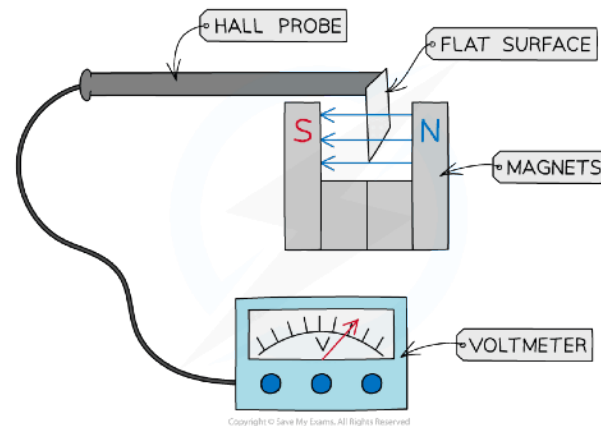
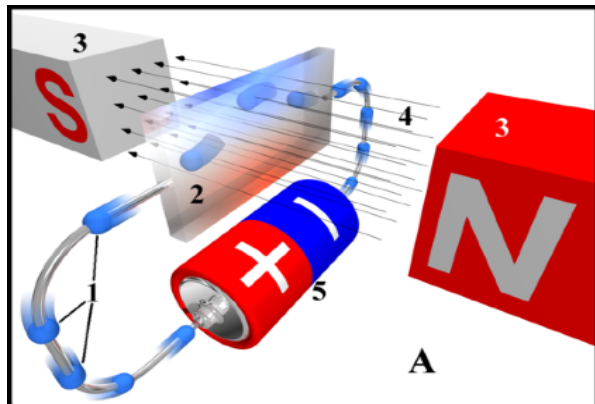
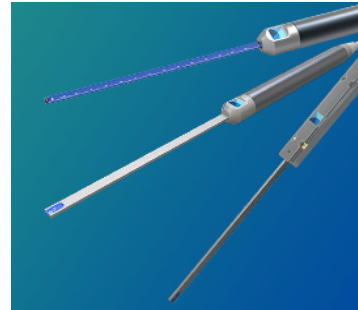

Coordinatometer

# Point by Point measurement : Hall Probe

The typical measurement setup foreseen Labview VI installed on a PC equipped with DAQ boards and a driver unit.

This setup allows to:

- Setup all the desired movements of the probe
- Acquire all the position and magnetic field data
- Write file output (txt format) with position and related field.

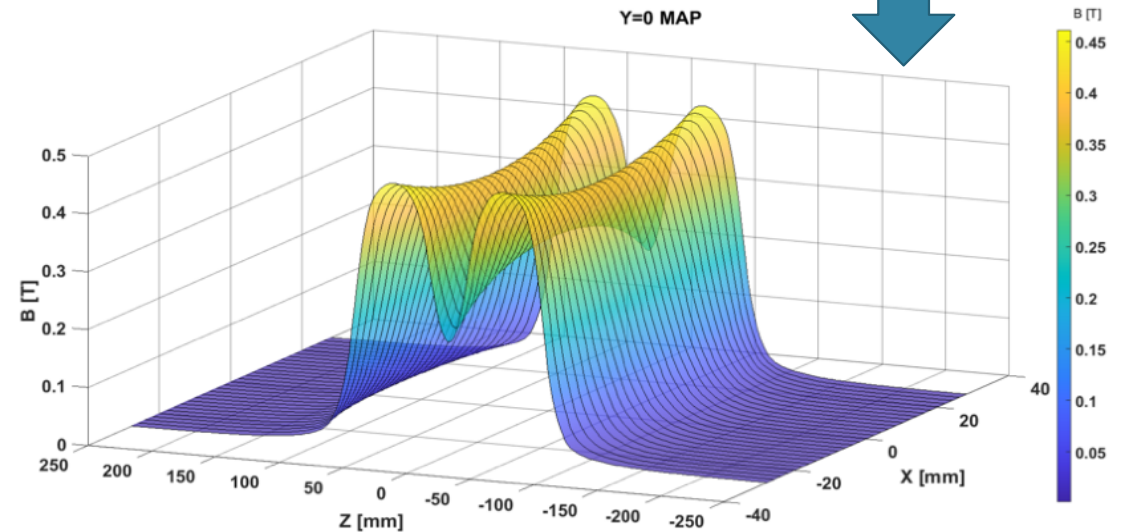
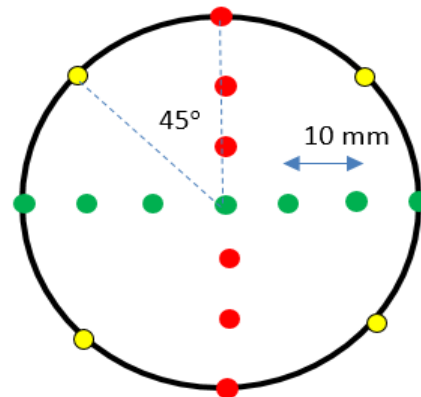
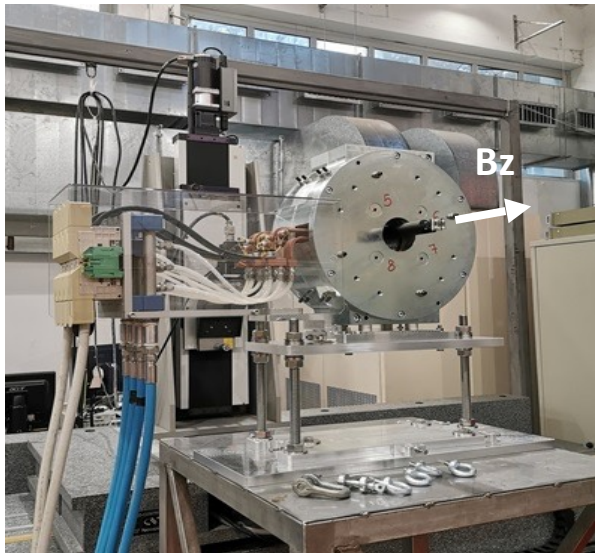
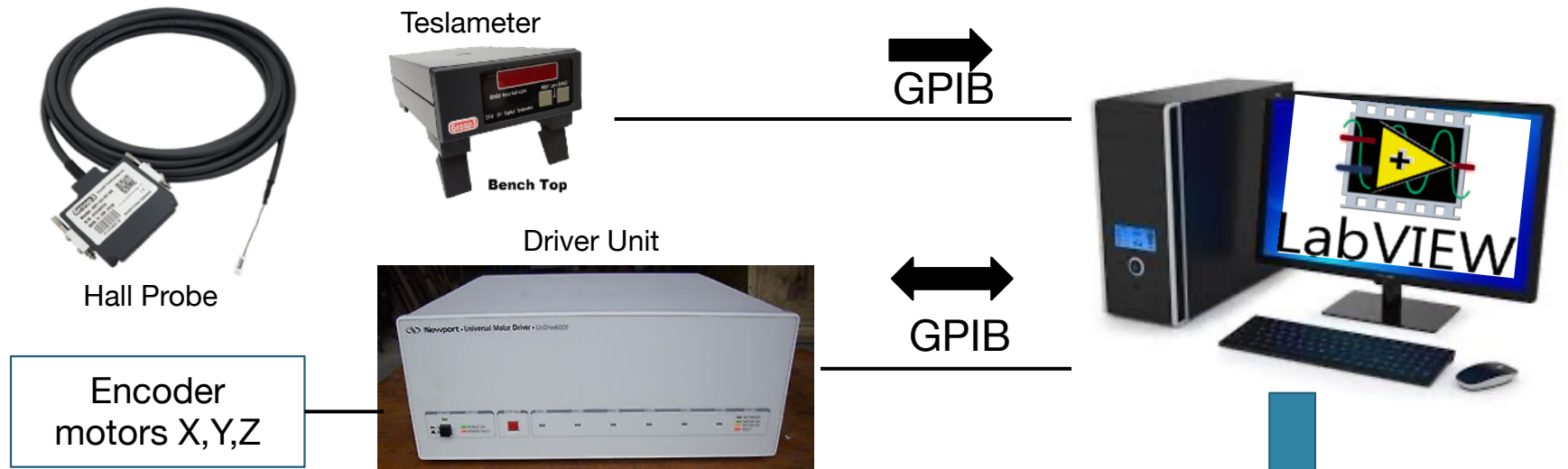

Campo magnetico in direzione longitudinale ( $B_z$ ) lungo le traiettorie rappresentate dai punti verdi



# Integrated Magnetic Measurement : Rotating Coil

- The periodic signal from the coil (sinusoidal) is acquired and processed using FFT.
- All the series coefficients are divided by the main component (i.e., quadrupolar) to derive the relative content for all the harmonics and ensure that it falls within the required range.
- The integrated field is then checked.

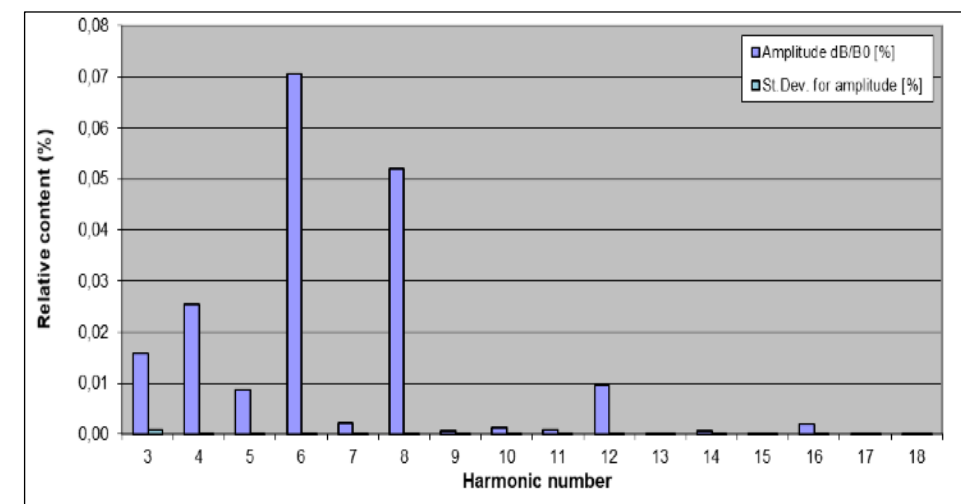
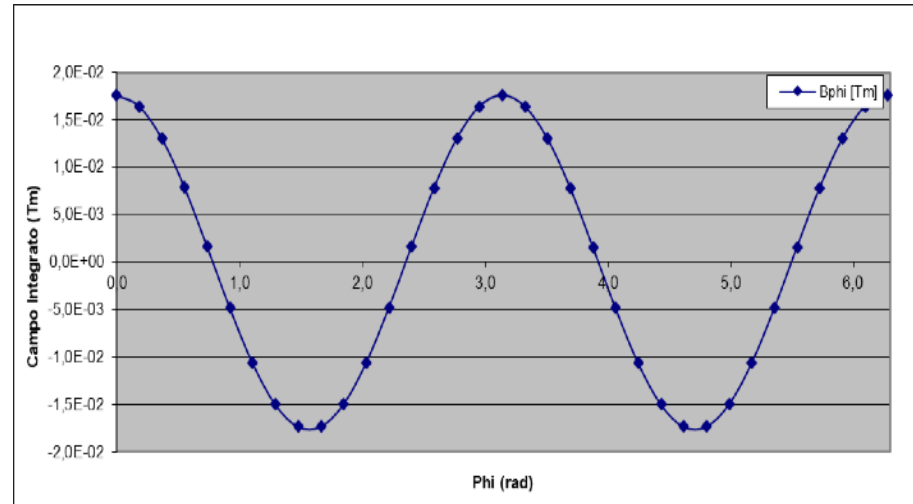
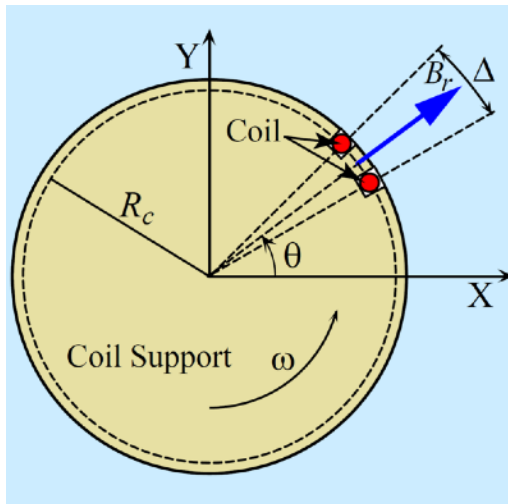
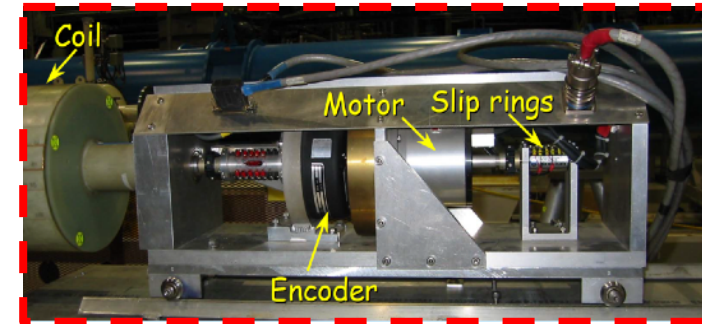
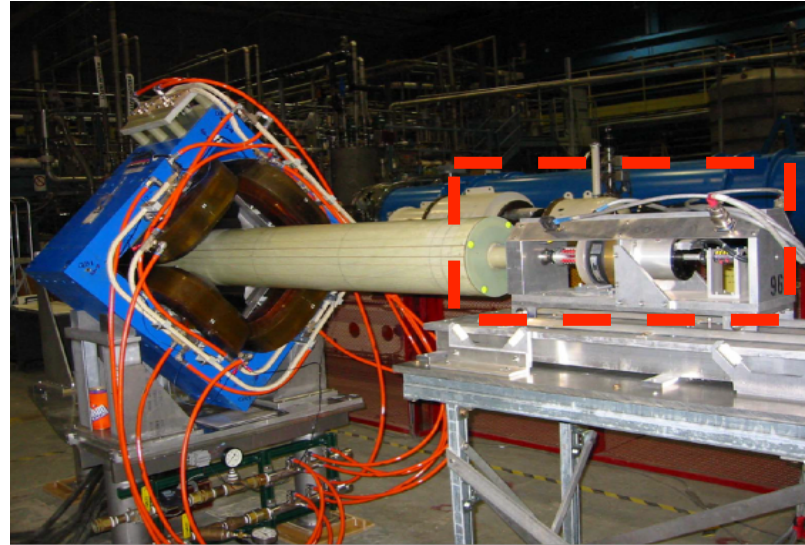

# Integrated Magnetic Measurement : Rotating Coil

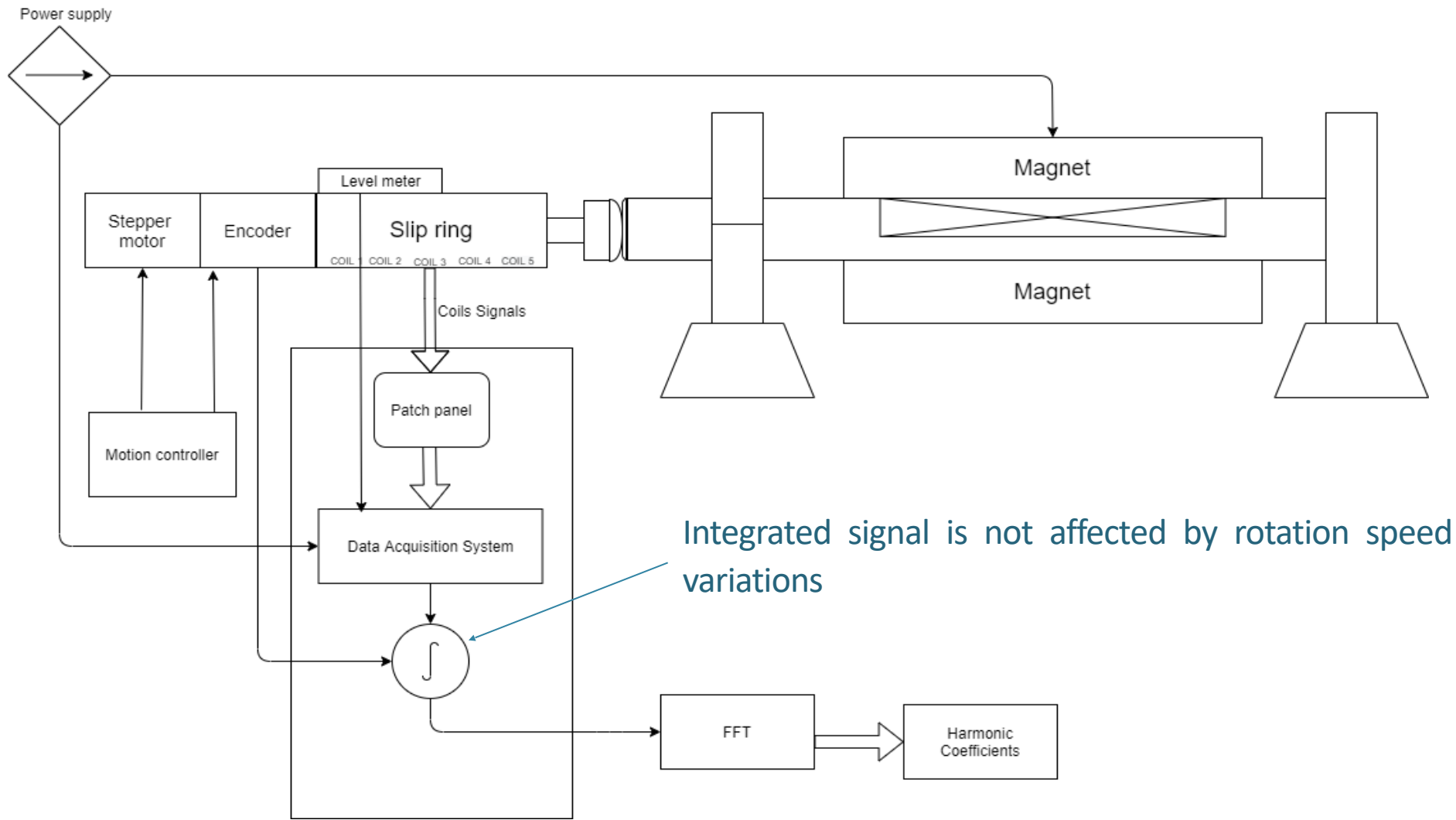

# Integrated Magnetic Measurement : Stretched Wire

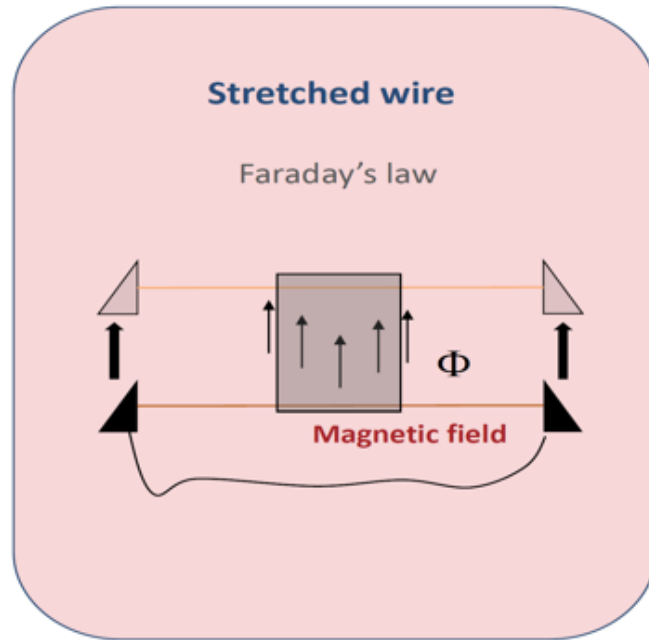

- We have a coil comprised of a fixed part and a movable part (the wire), both made of electrical conductor material.
- The wire experiences the magnetic field generated by the tested magnet.
- By moving the wire using a high-precision stage, the area of the coil varies accordingly.
- This variation in area corresponds to a change in magnetic flux, thus inducing a voltage on the coil terminals:

$$e . m . f . = - \frac{d\Phi}{dt}$$

- It is possible to define the integrated magnetic field along the wire length through a correlation between the induced voltage and the position of the wire.
- By moving the wire along circular trajectories, it is possible to perform the same harmonic analysis as that of a rotating coil.

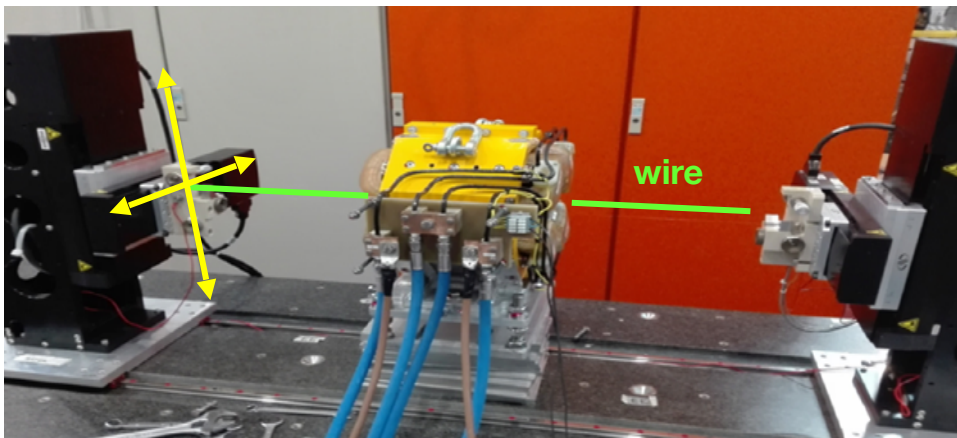

# Relevant Magnetic Parameters in Magnets

## DIPOLO MISURATO CON SONDA HALL

Parametro da misurare	Grandezze ricavate
Profilo longitudinale di Campo su più traiettorie (direzione del fascio)	Campo magnetico integrato
	Angolo di deflessione (conoscendo Energia fascio)
	Qualità integrata di campo
Profilo trasverso di Campo	Qualità di campo «puntuale»
Corrente vs Induzione magnetica	Funzione di Trasferimento $I \rightarrow B$

## QUADRUPOLO MISURATO CON SINGLE STRETCHED WIRE (SSW)

Parametro da misurare	Grandezze ricavate
Tensione indotta filo SSW su traiettoria circolare	Gradiente integrato
	Armoniche integrate $\rightarrow$ Qualità di campo



# That's all folks!

## Thank you for the attention!