

# STUDY OF $^{84}\text{Ga}$ $\beta$ -DECAY AT ALTO

## Outline:

1. Motivation
2. Experiment
3. Results
4. Structure of  $^{84}\text{Ge}$
5. Conclusions

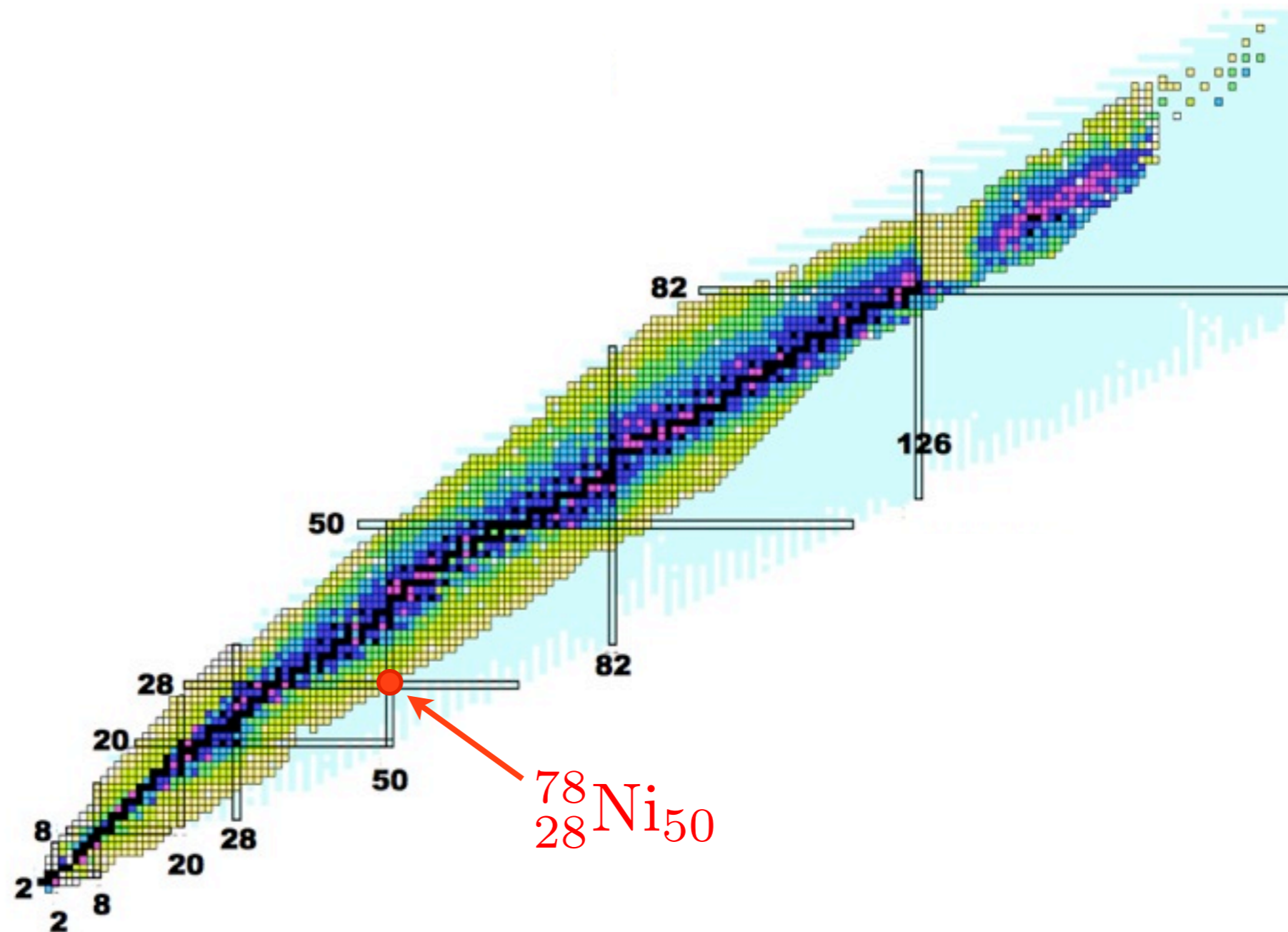

**Karolina Kolos**

Institut de Physique Nucléaire d'Orsay

# $^{78}\text{Ni}$ DOUBLY-MAGIC?

a good core for the shell model calculations?

what is the valence space that opens above?

study the nuclear structures of elements in the vicinity of  $^{78}\text{Ni}$

$^{84}\text{Ge}$ ,  $^{83}\text{Ge}$

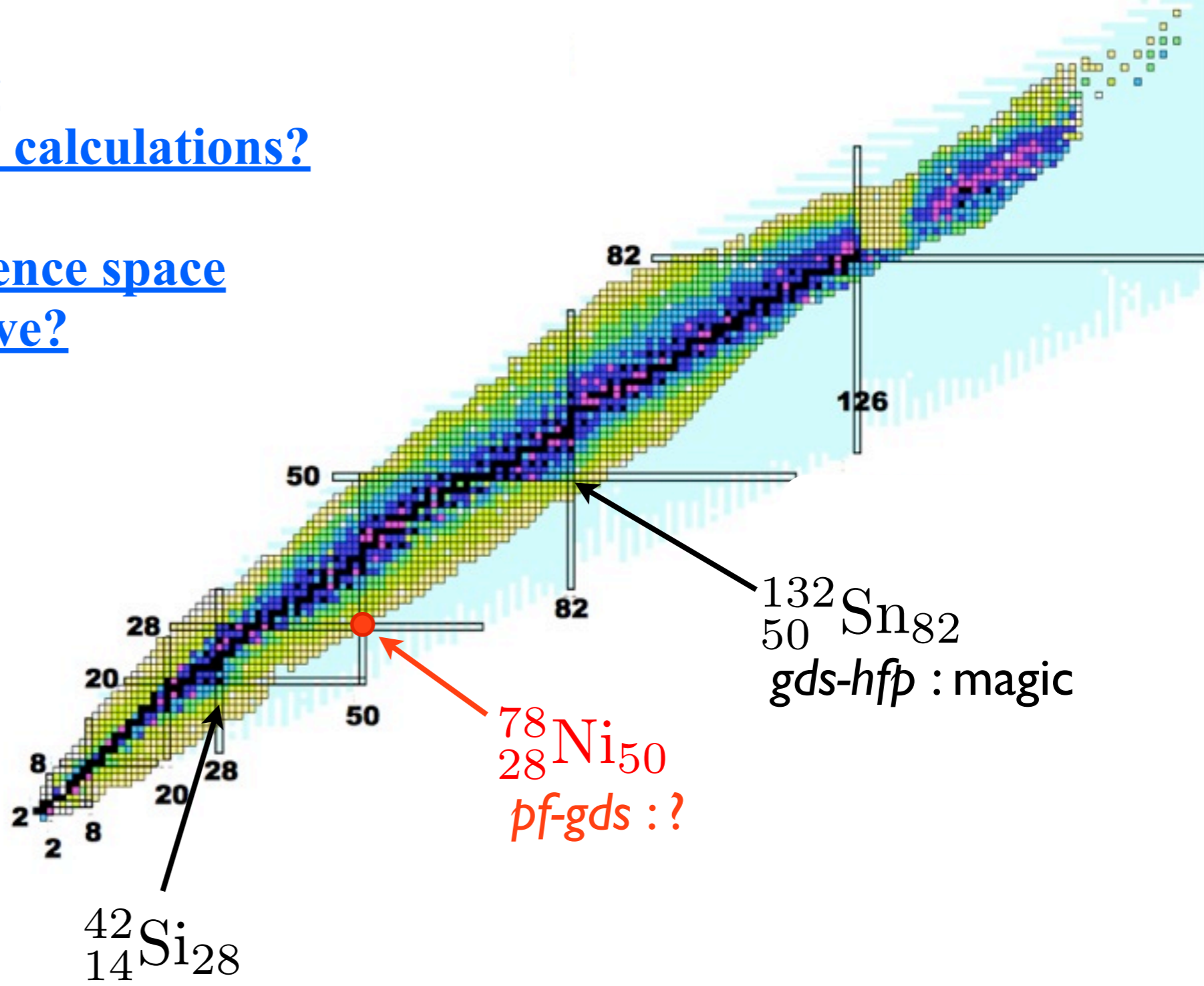

$sd$ - $pf$  : deformed

Bastin et al.

PRL 99 (2007) 022503

weakening of the spin-orbit effect

# DECREASE OF N=50 SHELL GAP?

N=50

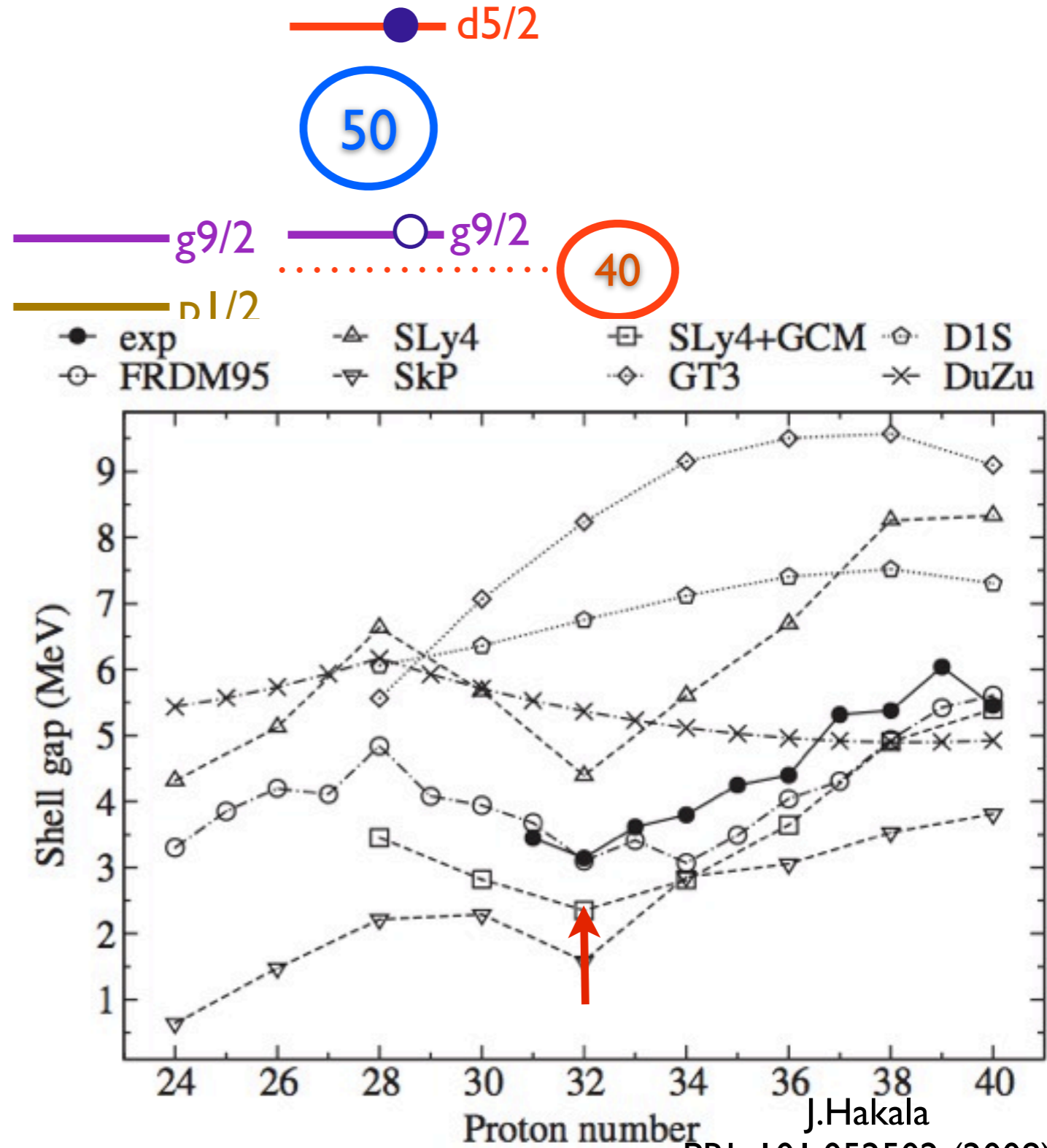
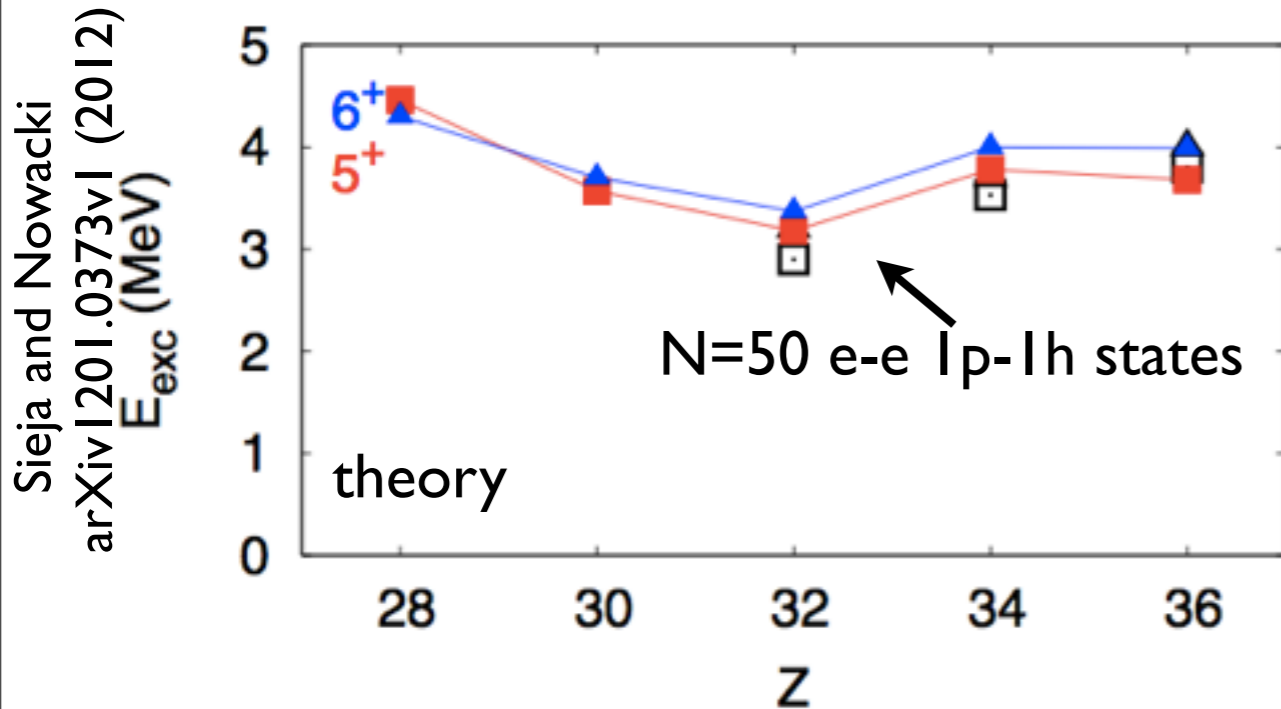
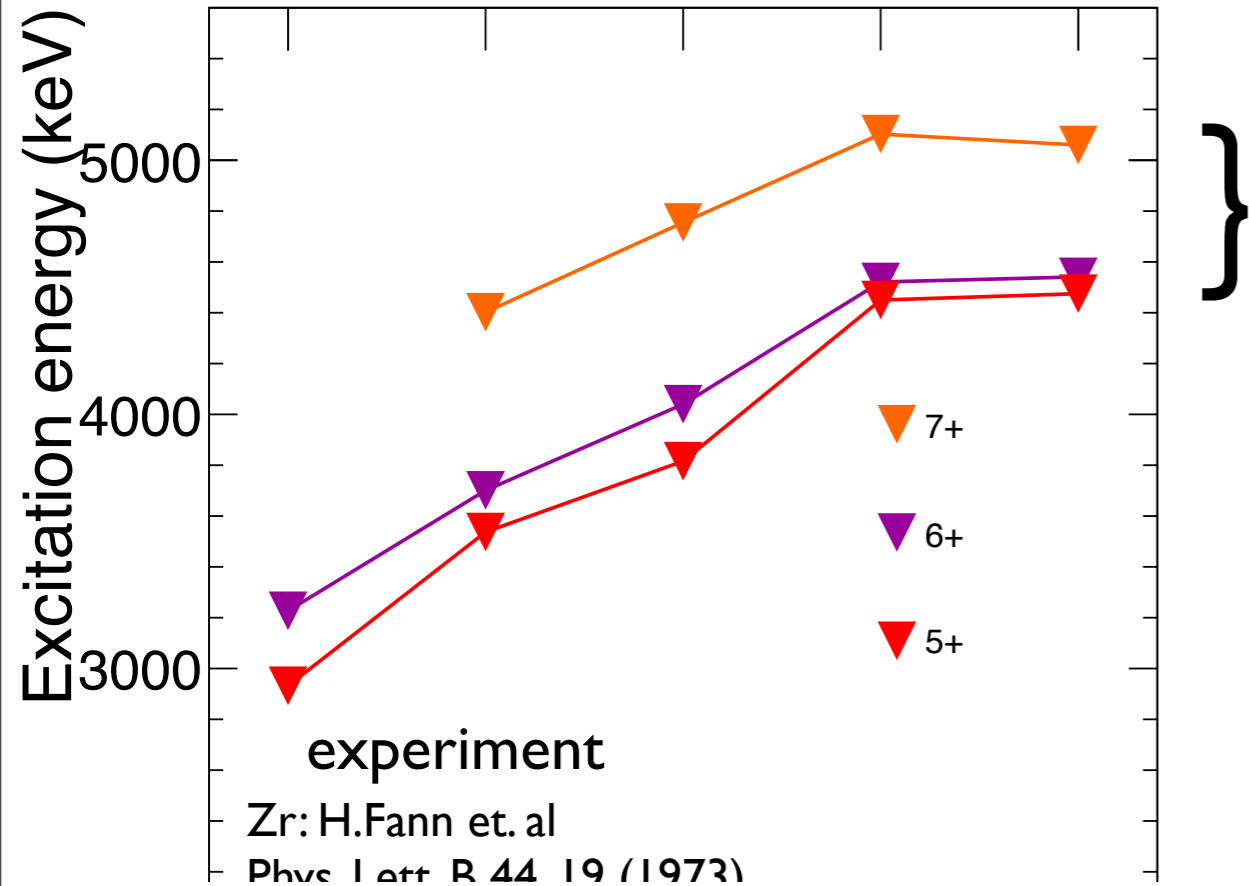

## $^{84}\text{Ga}$ $\beta$ -DECAY STUDY

### Experimental conditions:

- 10  $\mu\text{A}$  e- beam on UCx target (ALTO IPN Orsay)
- laser ion source
- PARRNe mass separator
- movable mylar tape station (cycles 4s+1s)

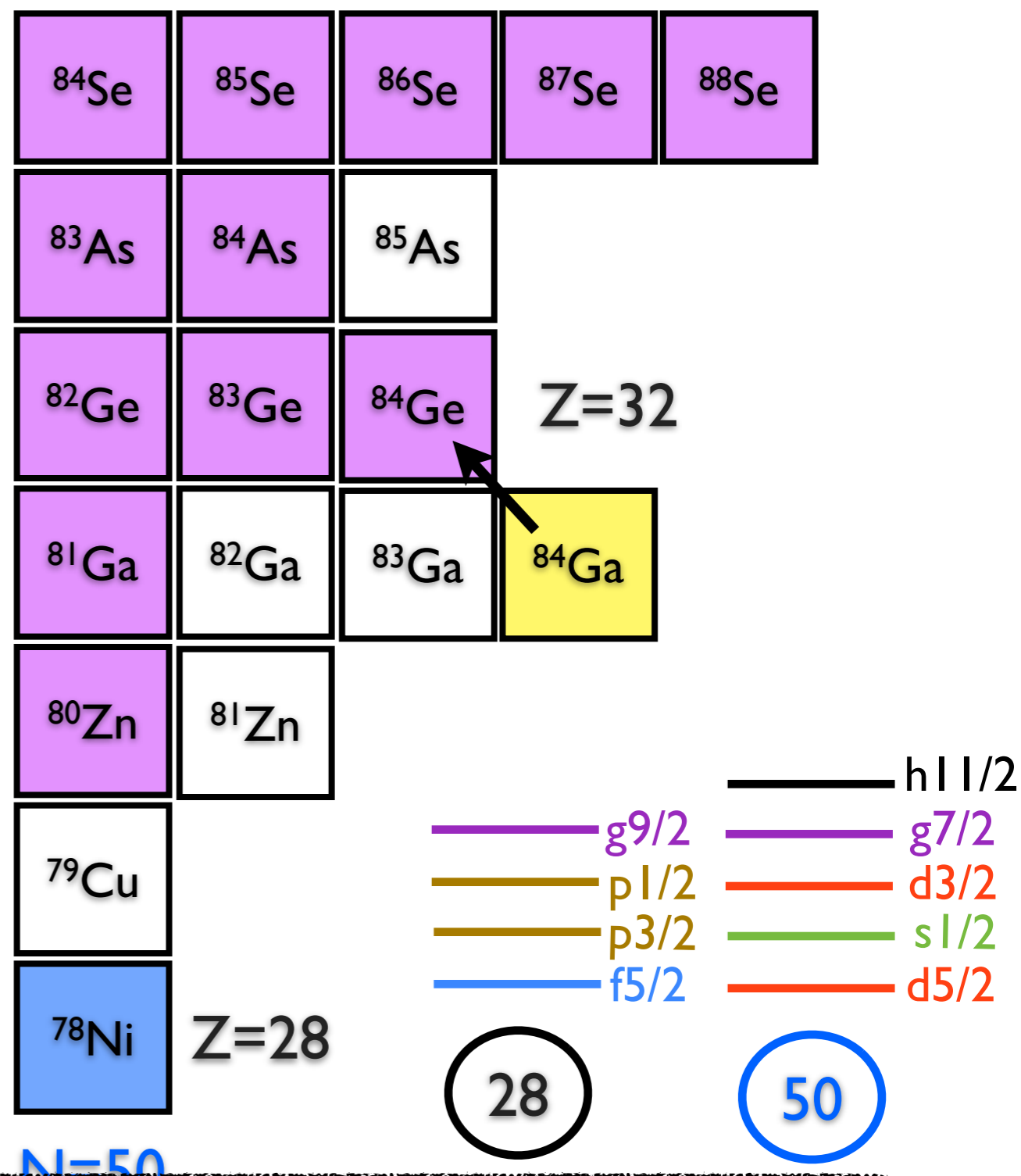

May 2012 authorization for exploitation of ALTO

# ORSAY ISOL INSTALLATION

e-LINAC  
10  $\mu$ A  
50MeV

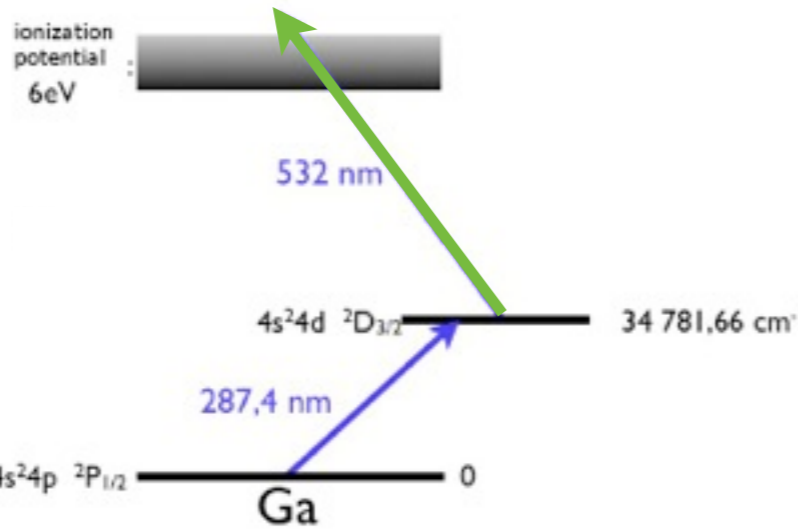
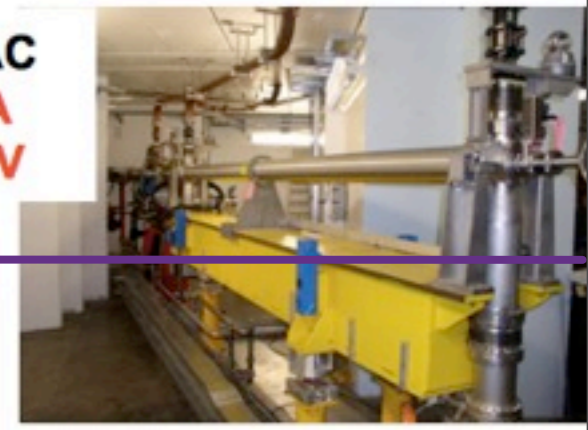

Detection system

TIS vault  
~5.10<sup>11</sup>  
fissions/s



laser

PARRNe  
mass separator

Target ion-source ensemble

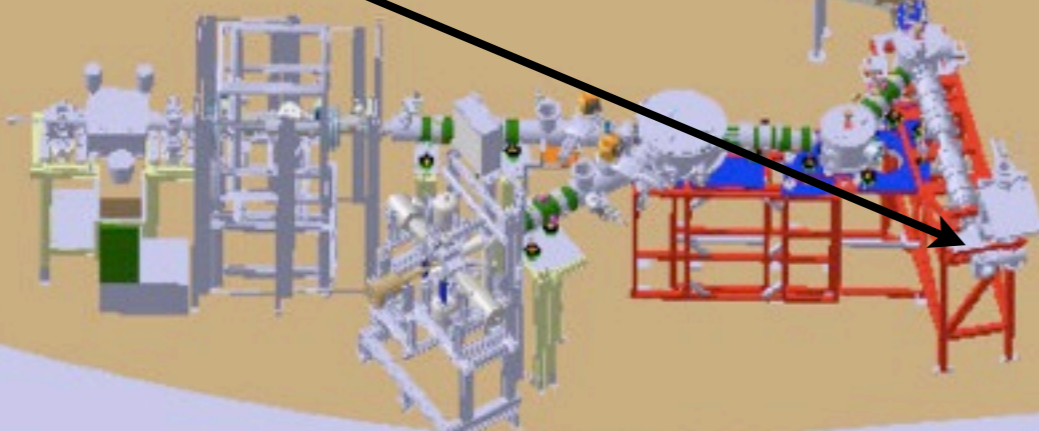
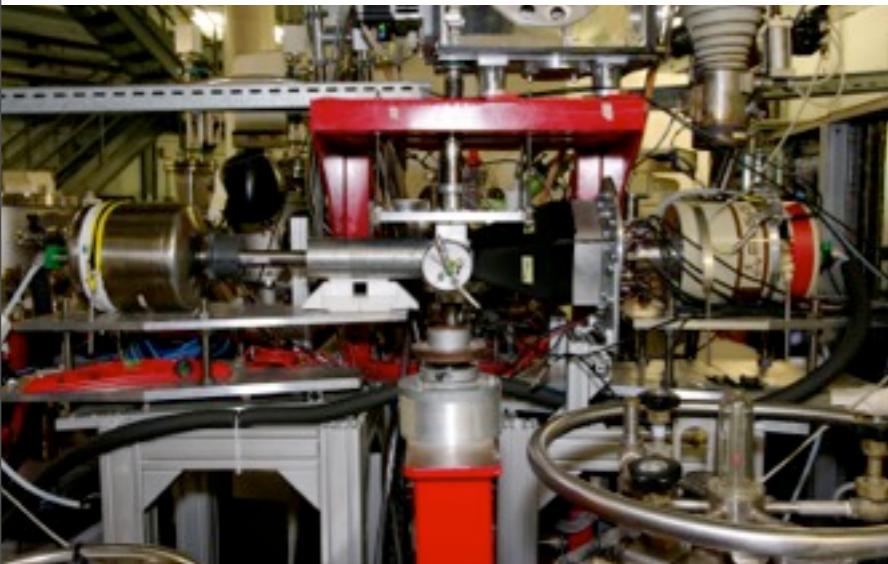
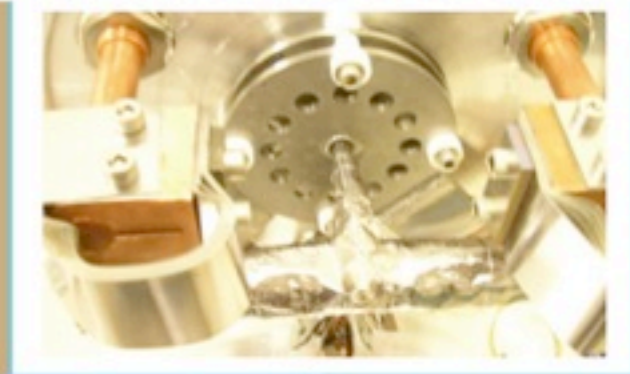

# LASER VS SURFACE IONIZATION

$^{84}\text{Ga} \rightarrow ^{84}\text{Ge}$   
 $T_{1/2} = 0.085 \text{ s}$

$\beta$  gated  $\gamma$  spectrum

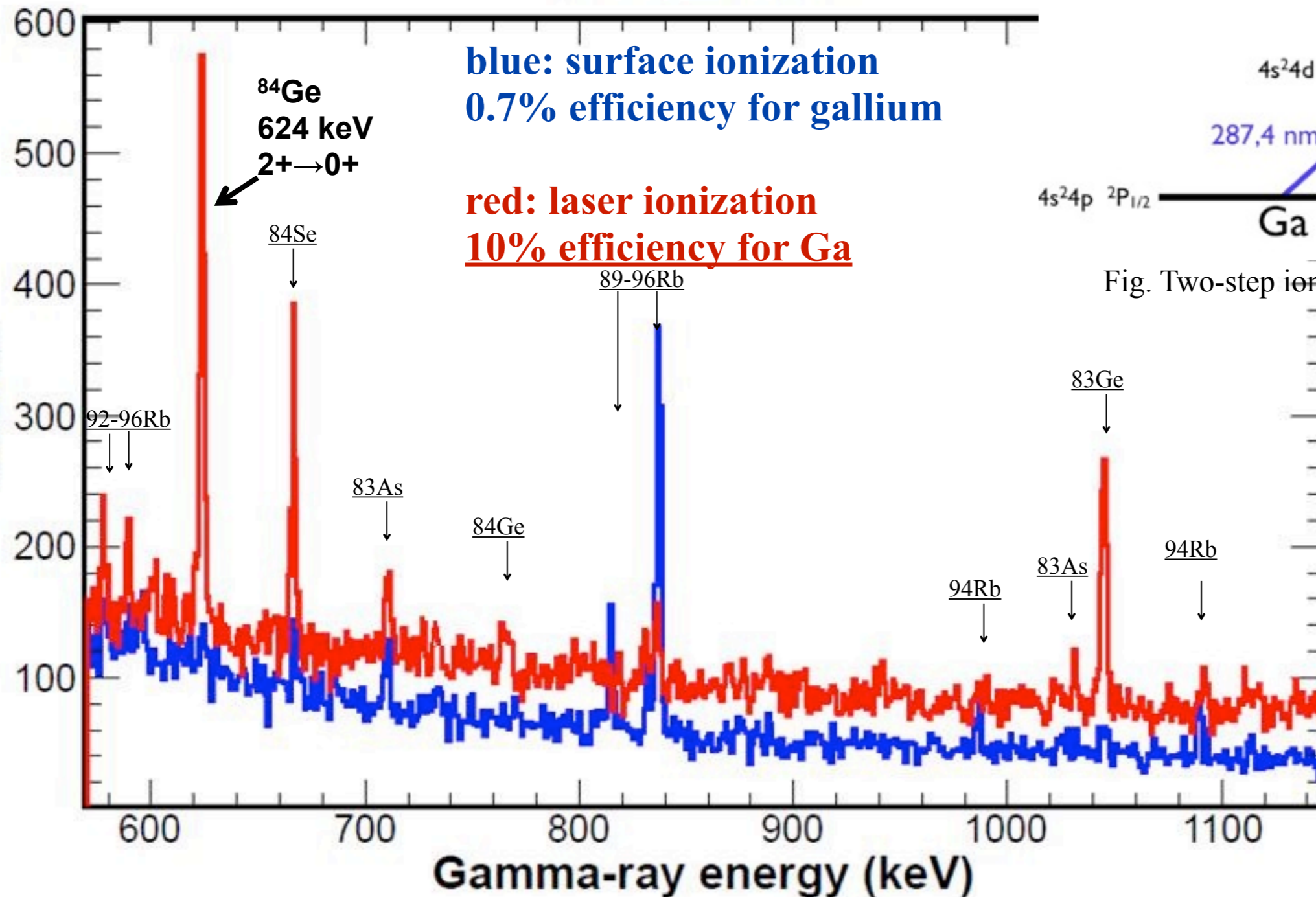

**blue: surface ionization**  
**0.7% efficiency for gallium**

**red: laser ionization**  
**10% efficiency for Ga**

ionization potential :  
6eV

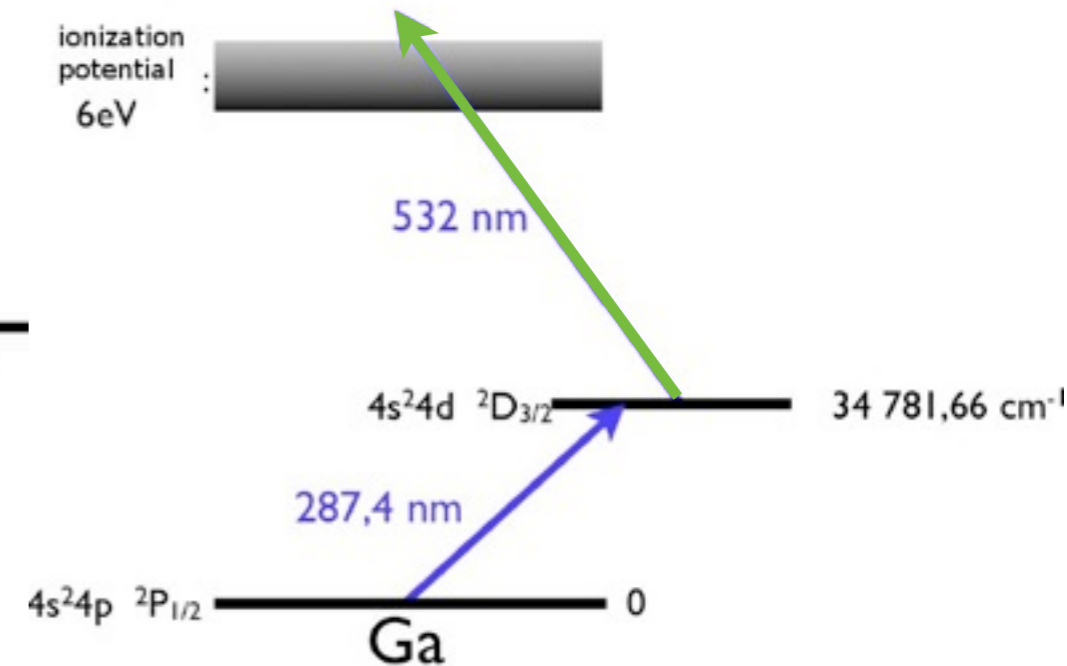
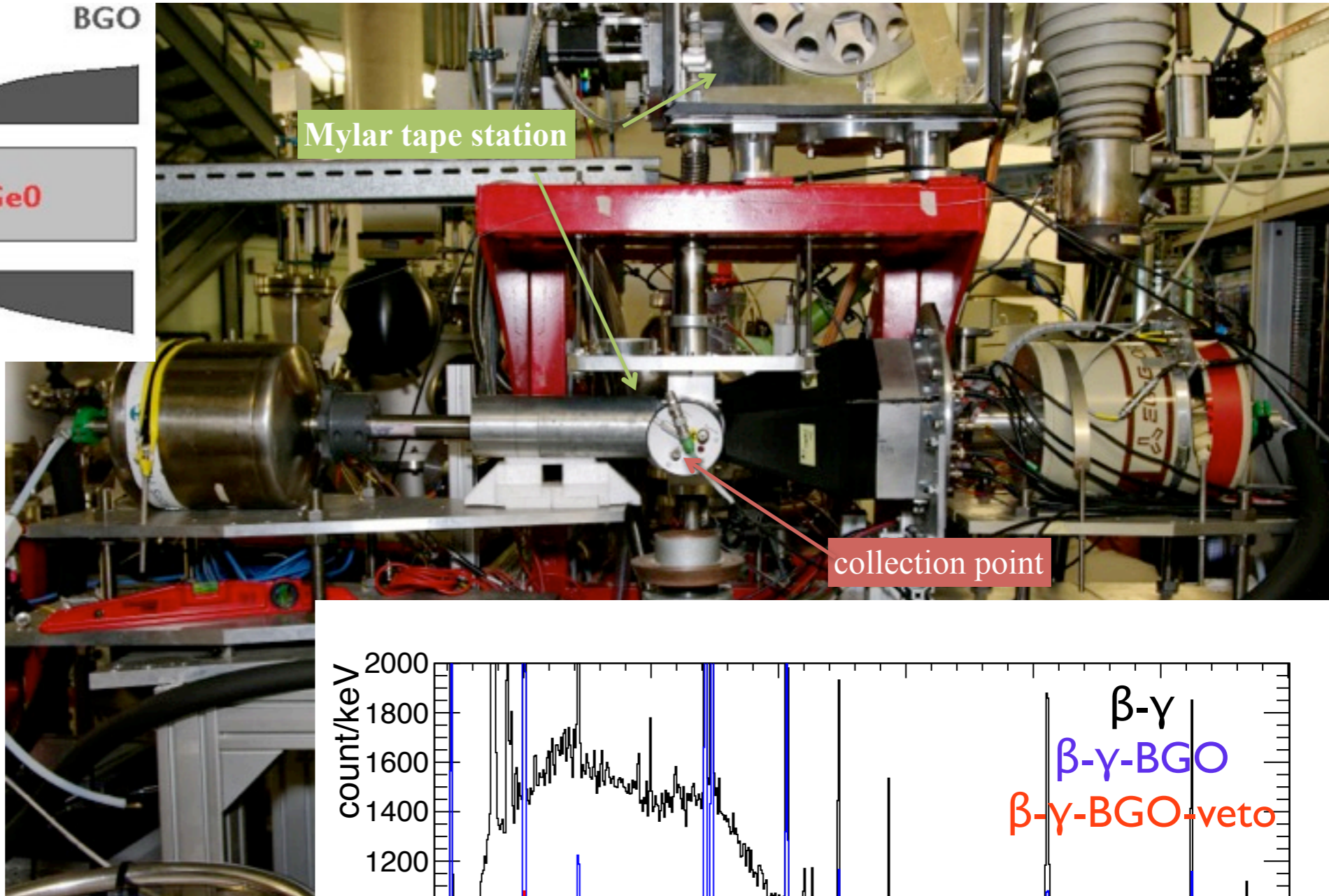
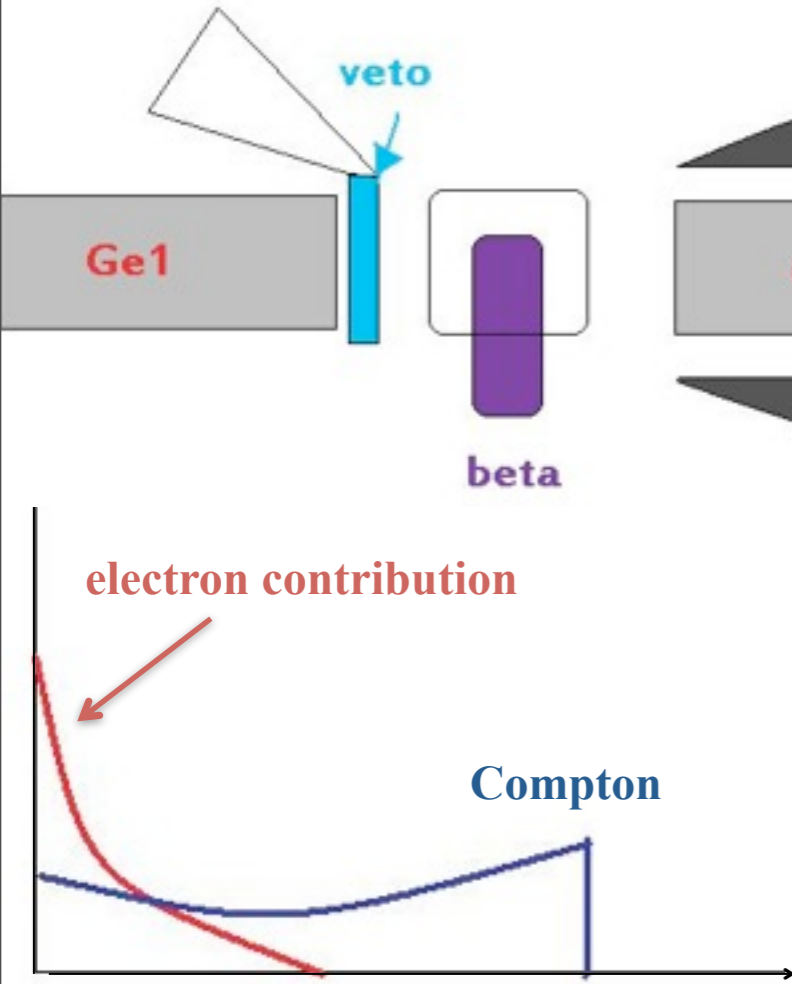

Fig. Two-step ionization scheme for gallium

**blue:**  
Rb from focal plane  
(random coincidences)

**red:**  
Rb background  
minimized thanks to  
a new shielding

# EXPERIMENTAL DETAILS



## Detection system:

- two coaxial germanium
- beta detector (plastic)
- veto detector (plastic)
- **BGO shield (prototype for ORGAM2)**

peak/bkg = 1.5  
 peak/bkg = 2  
 peak/bkg = 4

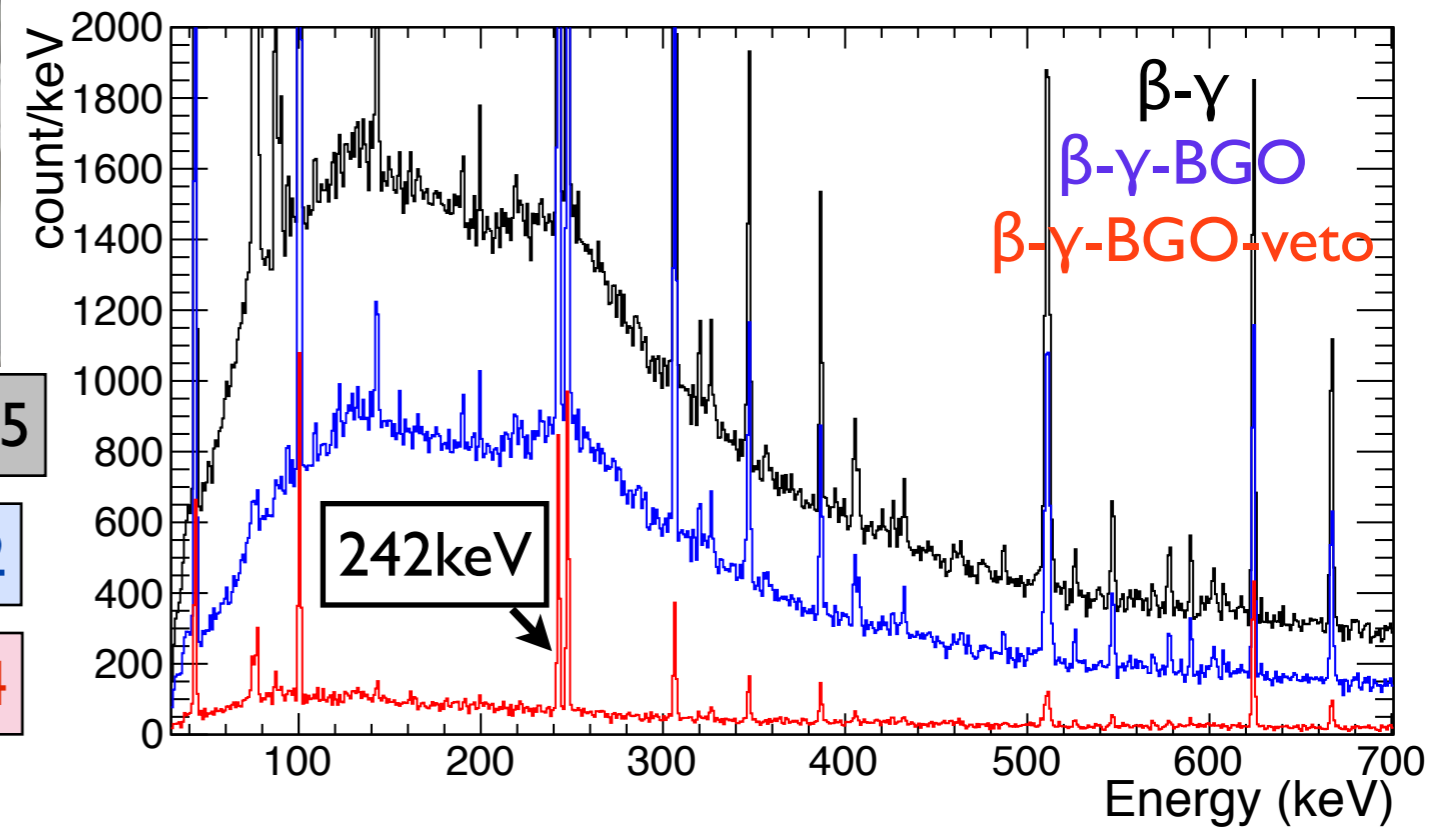

# BETA GAMMA SPECTRUM

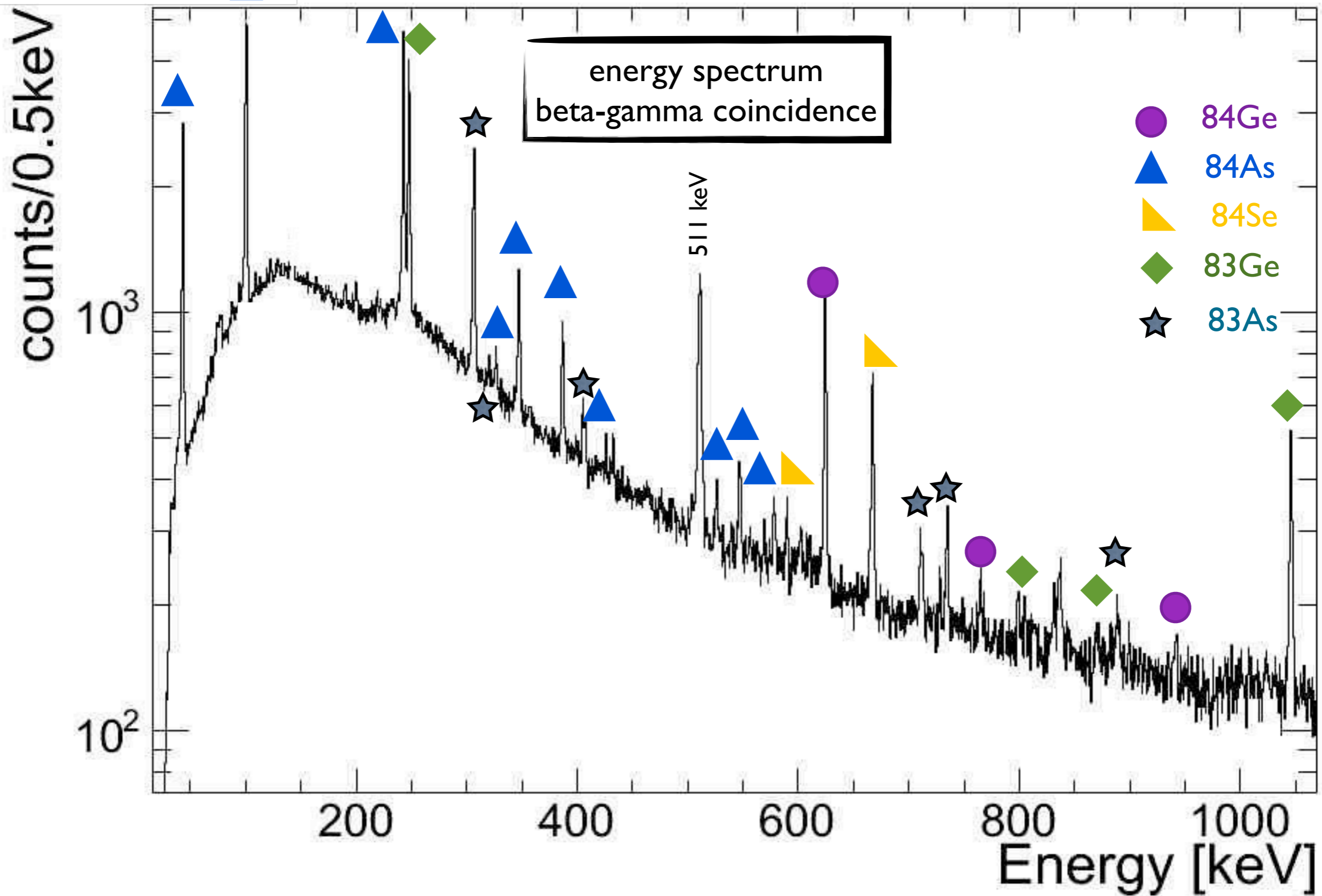

## DATA ANALYSIS: $^{84}\text{Ge}$

624 keV candidate  $^{84}\text{Ga} \rightarrow ^{84}\text{Ge}$   
 $^{84}\text{Ga} T_{1/2} = 0.085 (10) \text{ s}$

$$P \cdot (1 - e^{-\lambda t_{coll}})$$

half-live:  
 $0.097 \pm 0.017 \text{ s}$

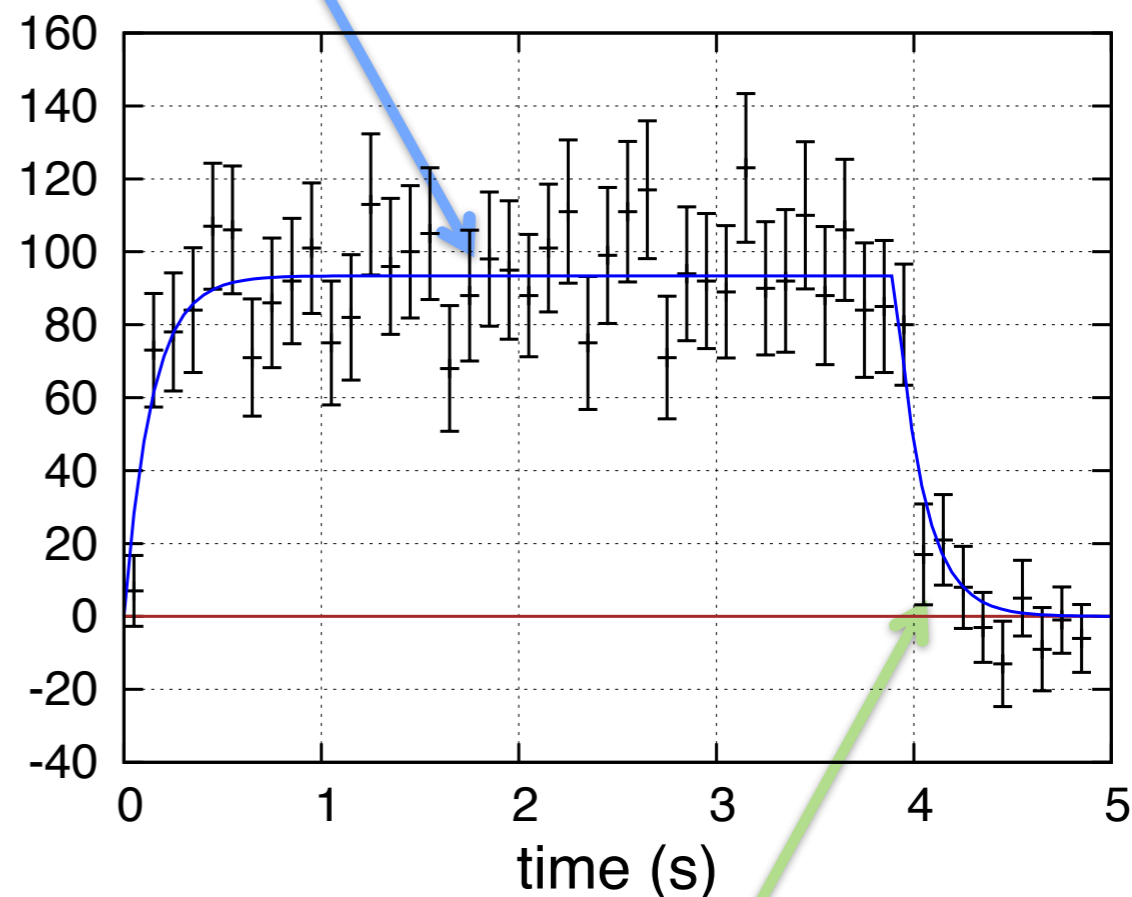
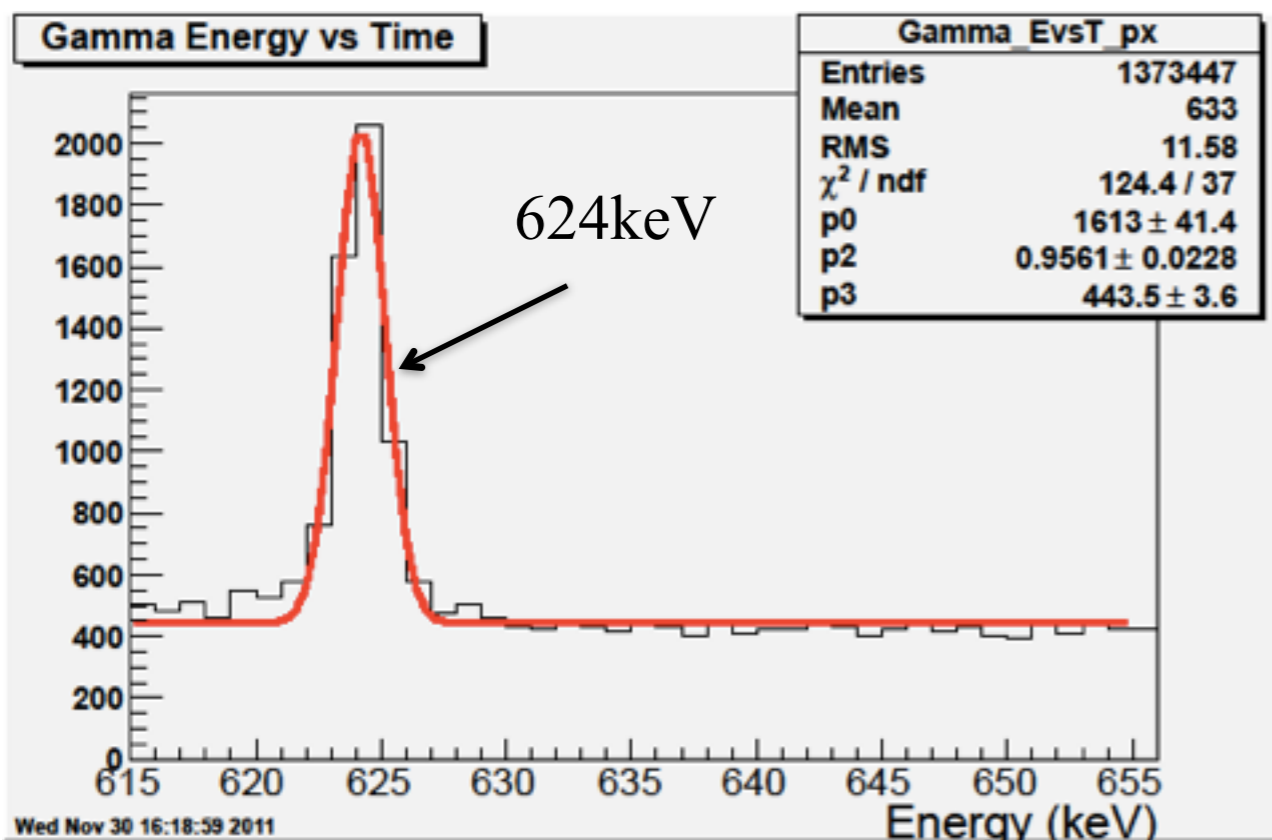

$$P \cdot (1 - e^{-\lambda t_{coll}}) \cdot e^{-\lambda t_{dec}}$$

# DATA ANALYSIS: $^{84}\text{Ge}$

624 keV candidate  $^{84}\text{Ga} \rightarrow ^{84}\text{Ge}$   
 $^{84}\text{Ga} T_{1/2} = 0.085 (10) \text{ s}$

$$P \cdot (1 - e^{-\lambda t_{coll}})$$

half-live:  
 $0.097 \pm 0.017 \text{ s}$

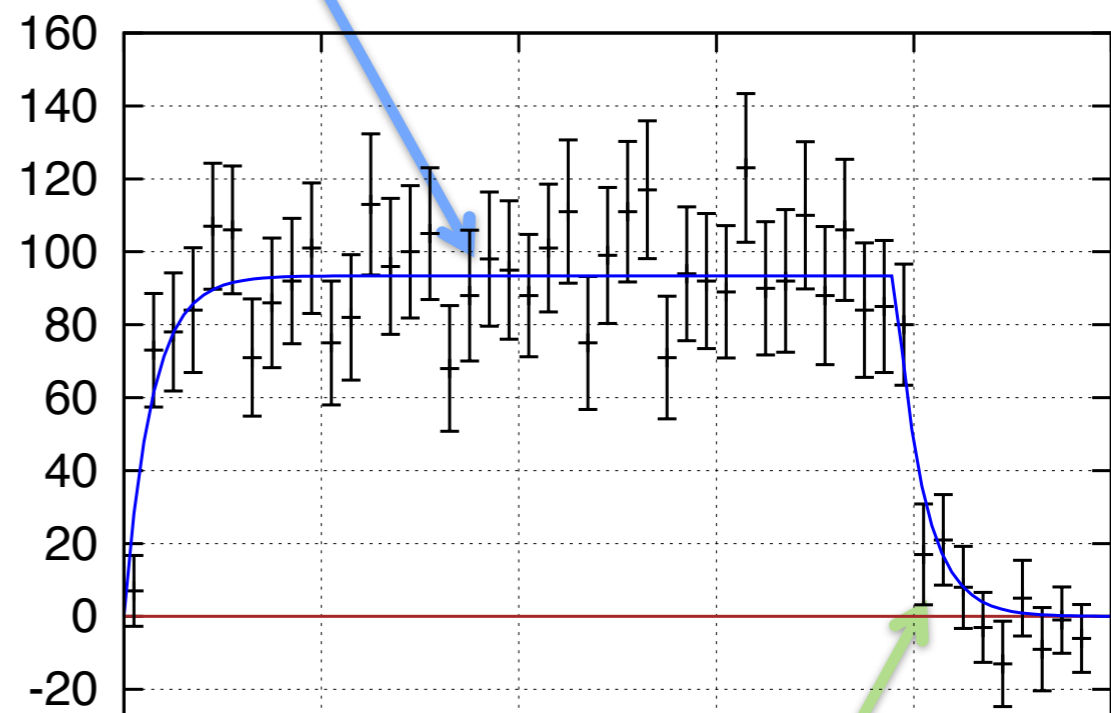
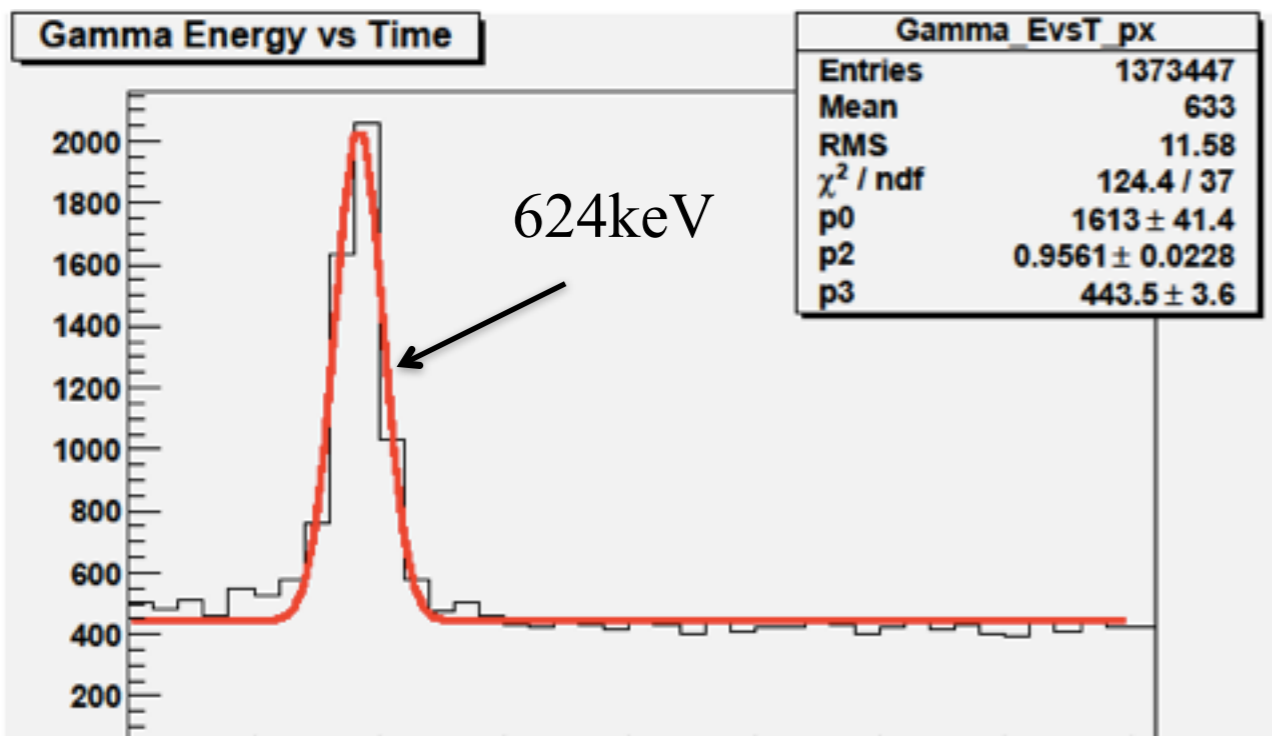

$$P \cdot (1 - e^{-\lambda t_{coll}}) \cdot e^{-\lambda t_{dec}}$$

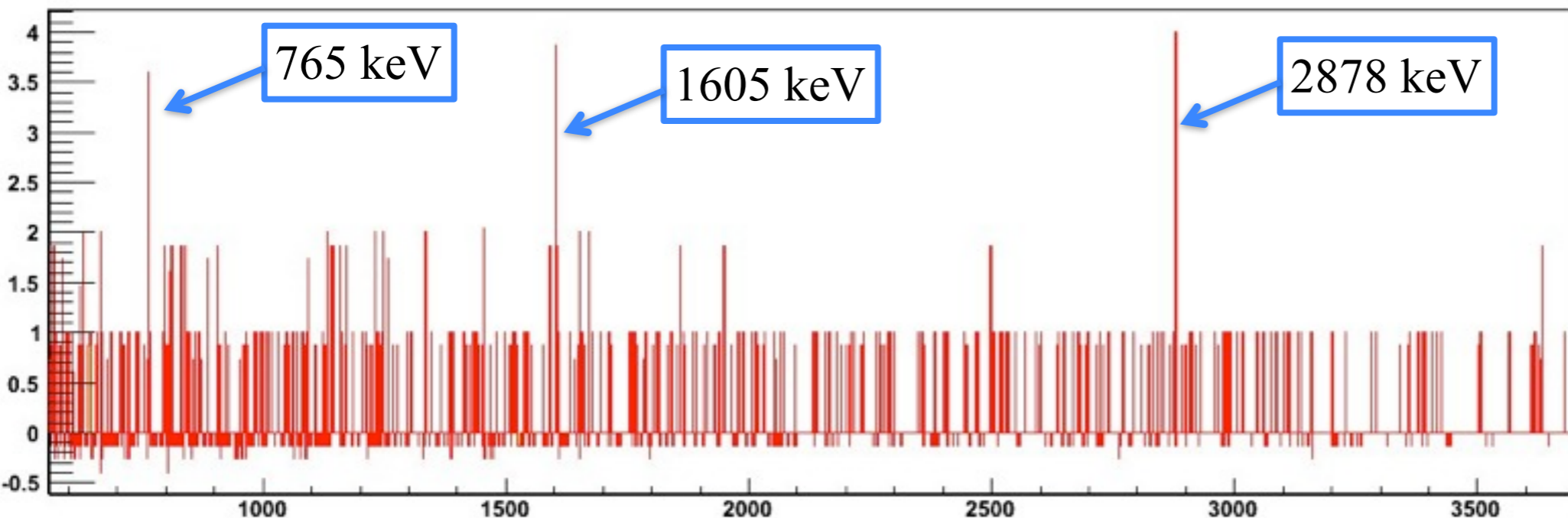

# RESULTS: $^{83,84}\text{Ge}$ LEVEL SCHEME

black: known

red: new

blue: not confirmed

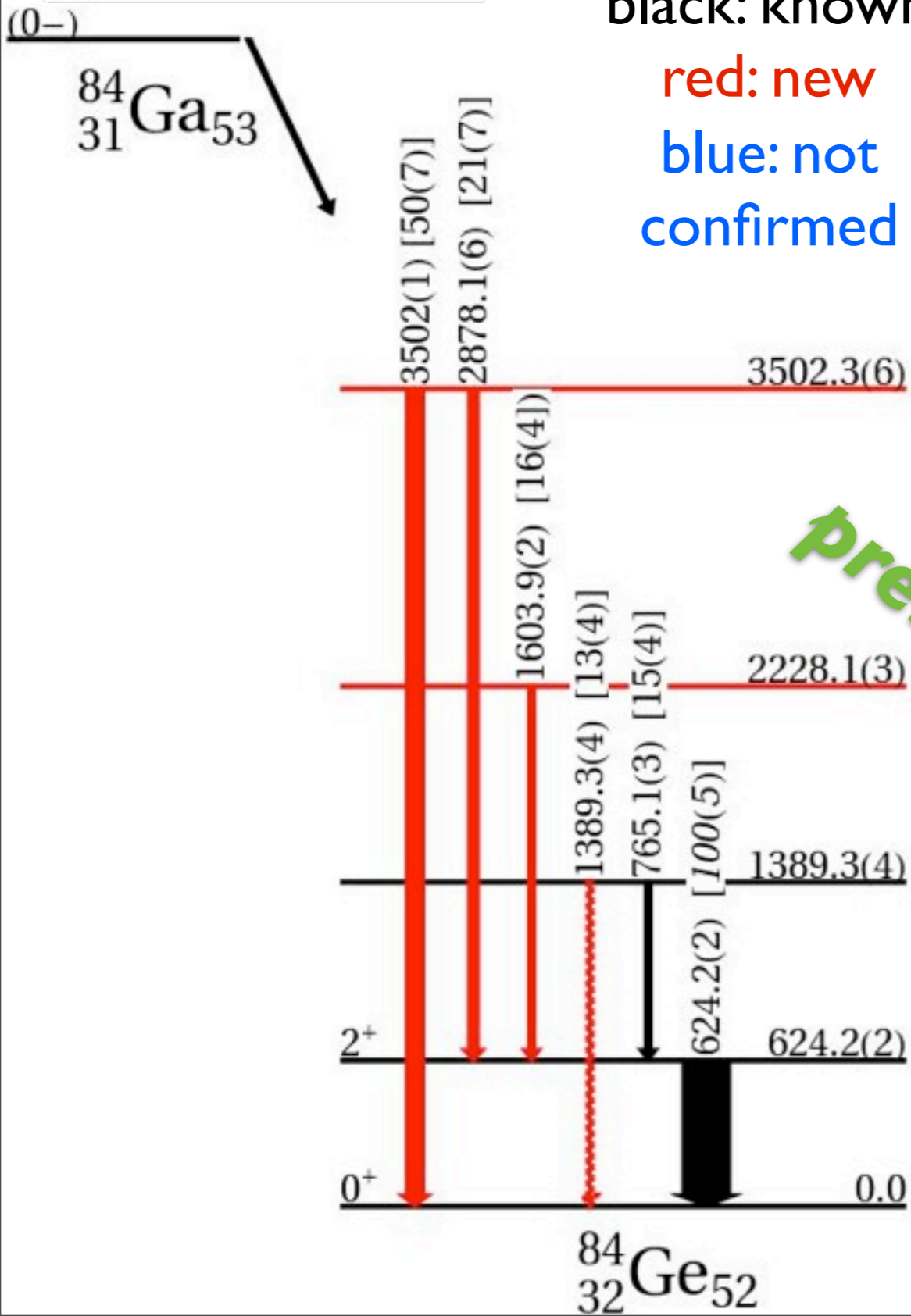

$P_n = 70(15)\%$

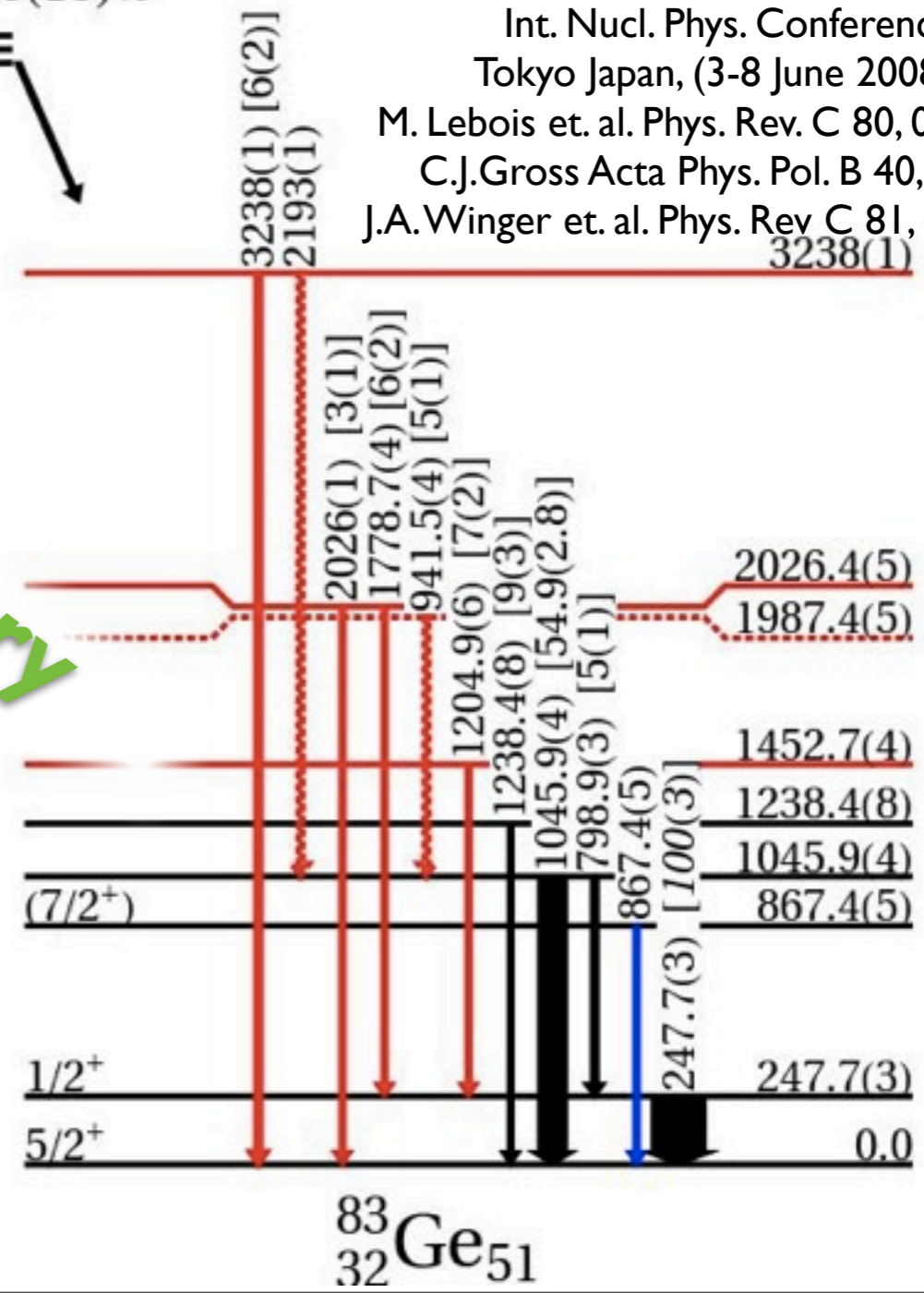

Preliminary

K.-L.Kratz et al. Z.Phys.A 340,419 (1991)  
D.Verney et. al. Braz. Jur. of Phys., vol34, 3A (2004)  
O.Perru et. al. Eur. Phys. J.A 28, 307 (2006)  
J.A.Winger et.al. Proc.4th Int.Conf.  
Fission and Properties of Neutron-Rich Nuclei,  
Sanibel Island (2007)  
J.A.Winger et. al. Proceeding of the 23rd  
Int. Nucl. Phys. Conference, V. 2,  
Tokyo Japan, (3-8 June 2008), p. 293  
M. Lebois et. al. Phys. Rev. C 80, 044308 (2009)  
C.J.Gross Acta Phys. Pol. B 40, 447 (2009)  
J.A.Winger et. al. Phys. Rev C 81, 044303 (2010)

# STRUCTURE OF $^{84}\text{Ge}$

(0-)

$^{84}_{31}\text{Ga}_{53}$

log ft

(2+)?

5.92(9)

(0+, 2+)?

6.79(14)

(0+, 2+)?

6.74(13)

6.60(12)

> 5.35(11)

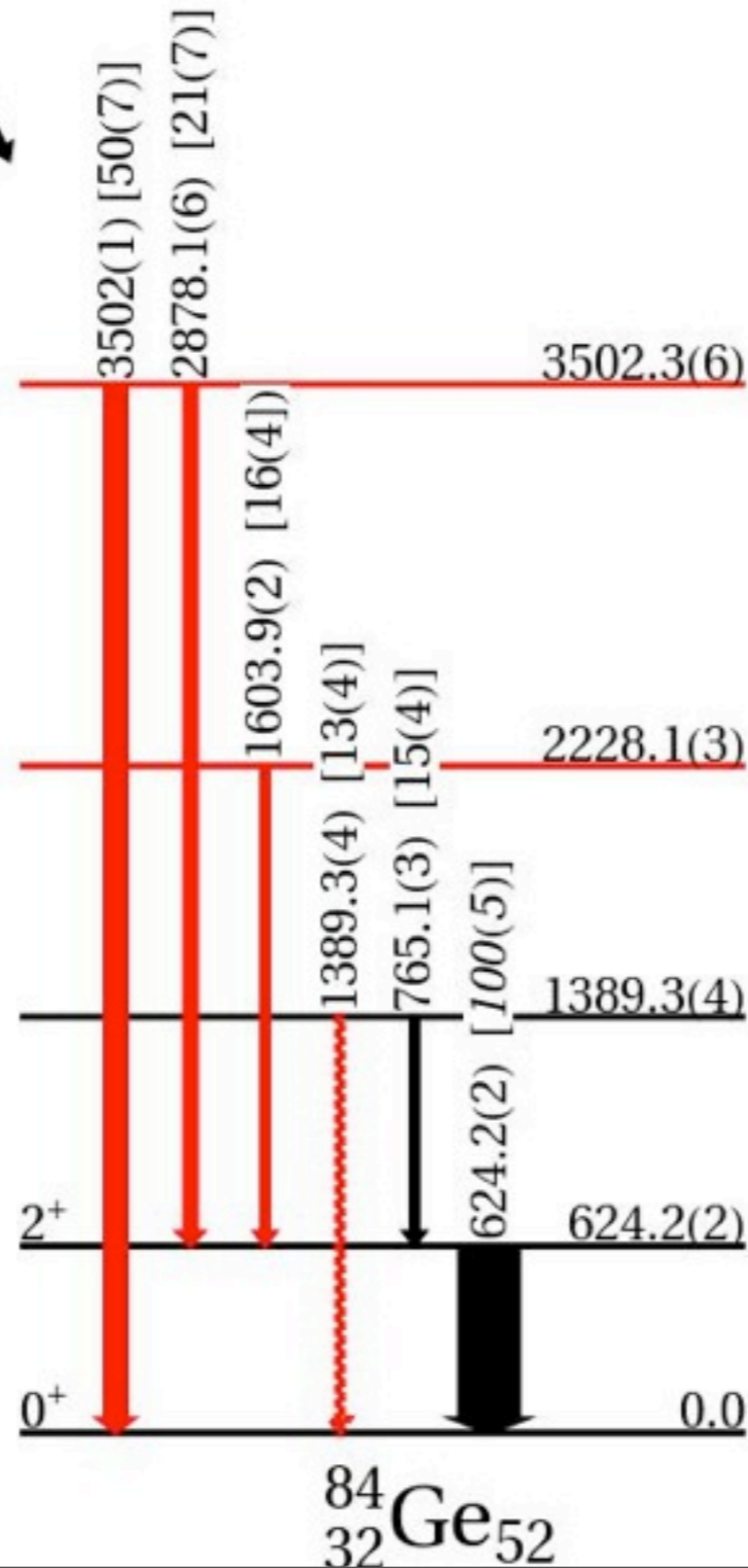

## Spin assignment:

$^{84}\text{Ga}$  (0-)

First-forbidden

non-unique:

$$\Delta J = 0, 1$$

$$\Delta P = \text{"-"}$$

$$0^- \rightarrow 0^+$$

First-forbidden

unique:

$$\Delta J = 2$$

$$\Delta P = \text{"-"}$$

$$0^- \rightarrow 2^+$$

# SHELL MODEL

## Interaction ni78-jj4b:

original interaction:

K.Sieja and F. Nowacki

Phys. Rev. C79,064310 (2009)

p-p part from jj4b interaction A.Brown core:  $^{78}\text{Ni}$

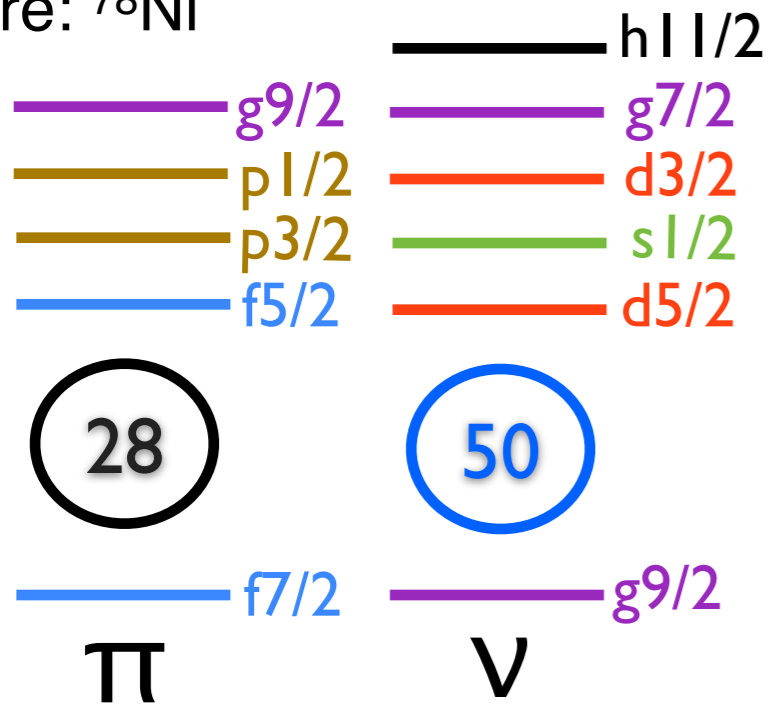

Effective Hamiltonian:  
 $H = H(\text{monopole}) + H(\text{multipole})$

spherical mean field

n=51, ESPE

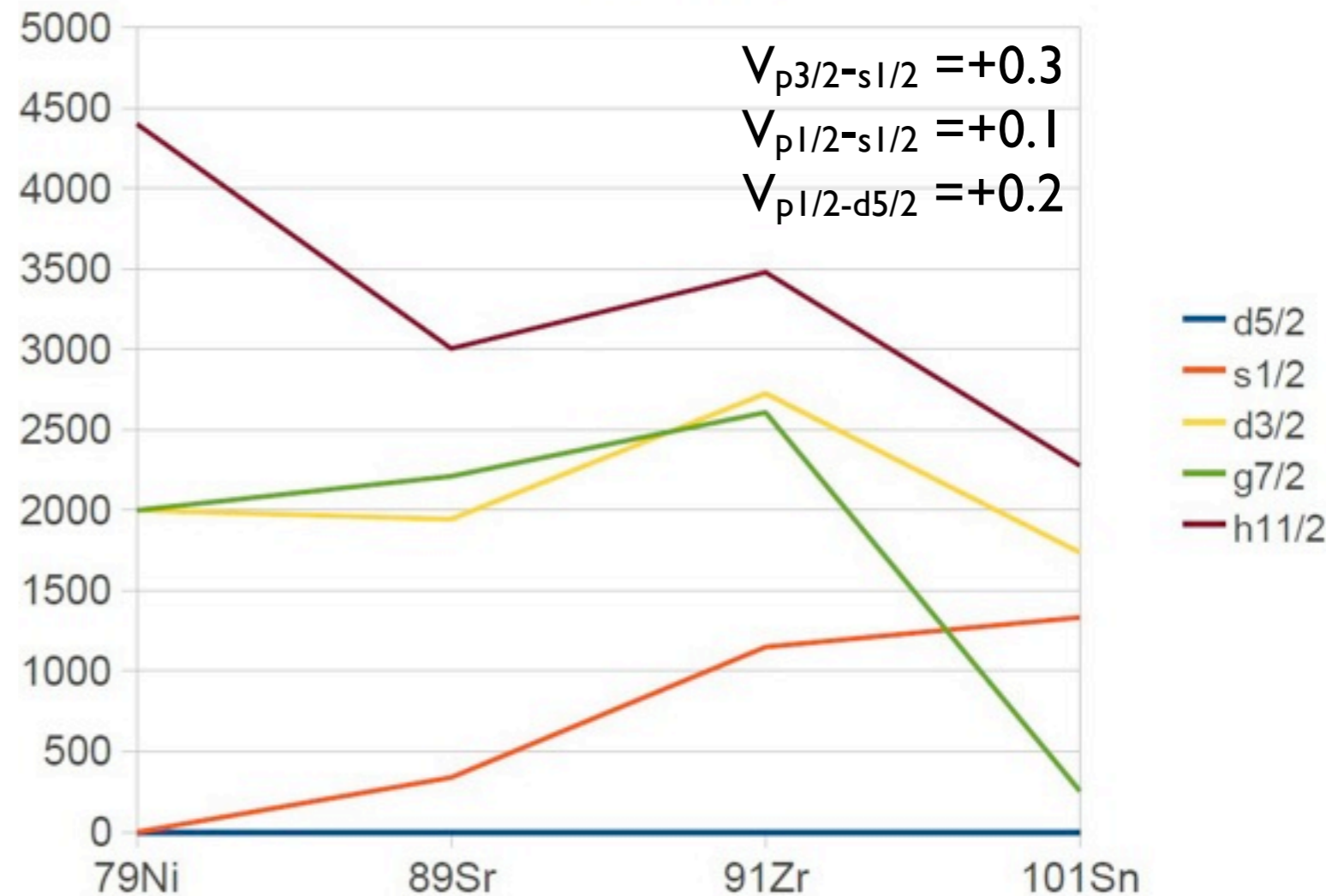

$$H_{monopole} = \sum_i n_i \epsilon_i + \sum_{i \leq j} n_i \cdot n_j V_{ij}$$

$$V_{ij}^T = \frac{\sum_J V_{ijj}^{JT} [2J+1]}{\sum [2J+1]}$$

# STRUCTURE OF $^{84}\text{Ge}$

(0-)

$^{84}_{31}\text{Ga}_{53}$

log ft

(2+)?

5.92(9)

(0+,2+)?

6.79(14)

(0+,2+)?

6.74(13)

6.60(12)

> 5.35(11)

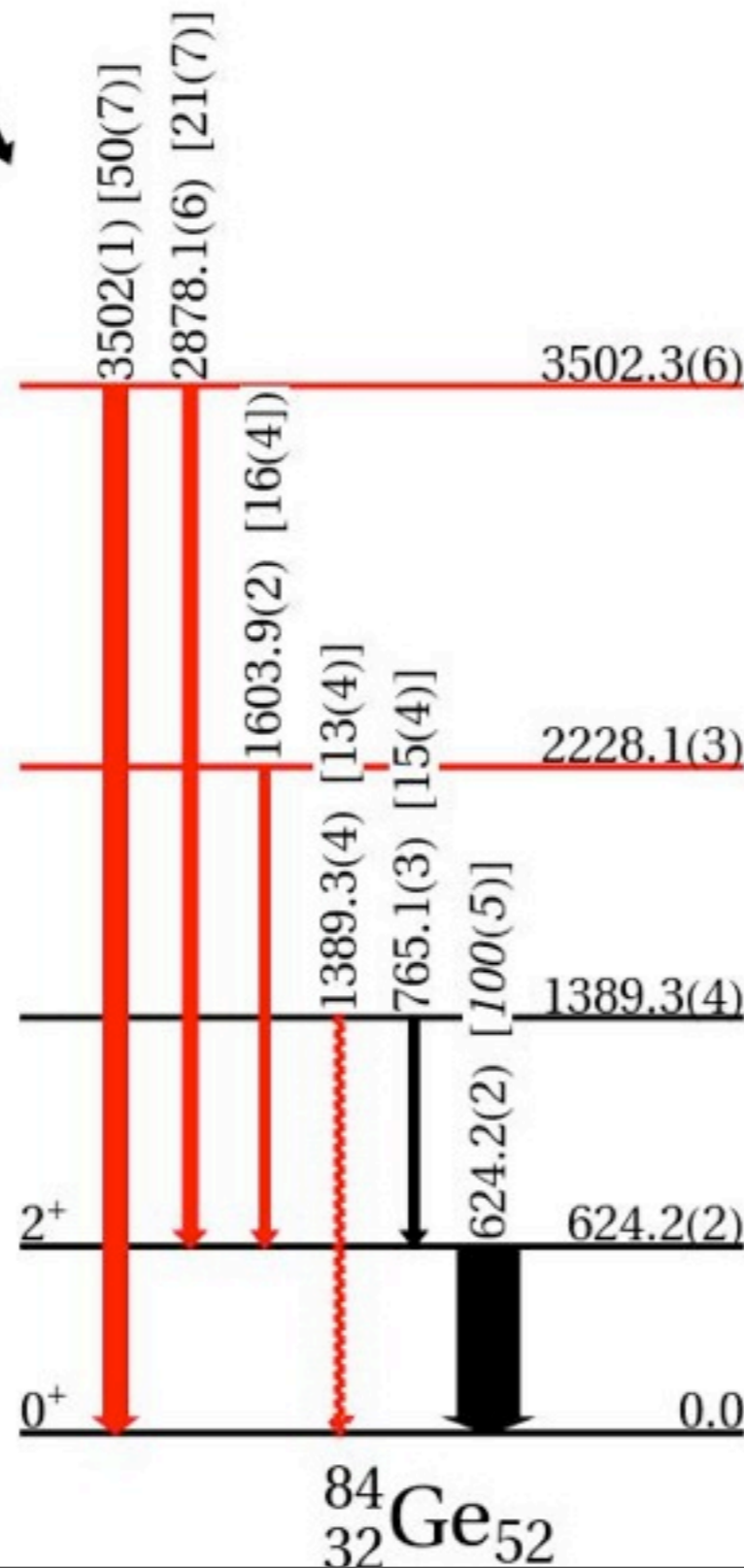

shell model calculation

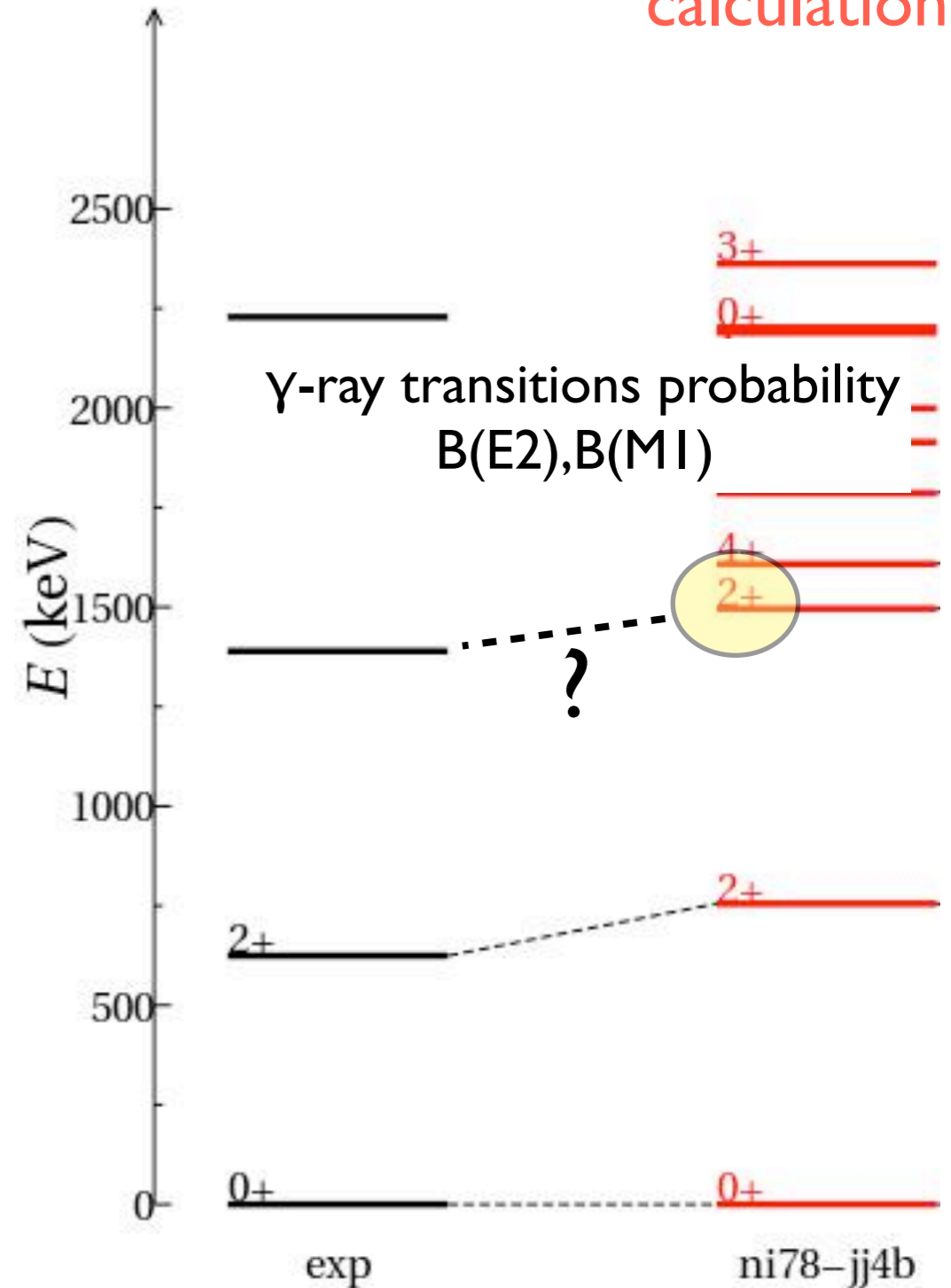

# STRUCTURE OF $^{84}\text{Ge}$

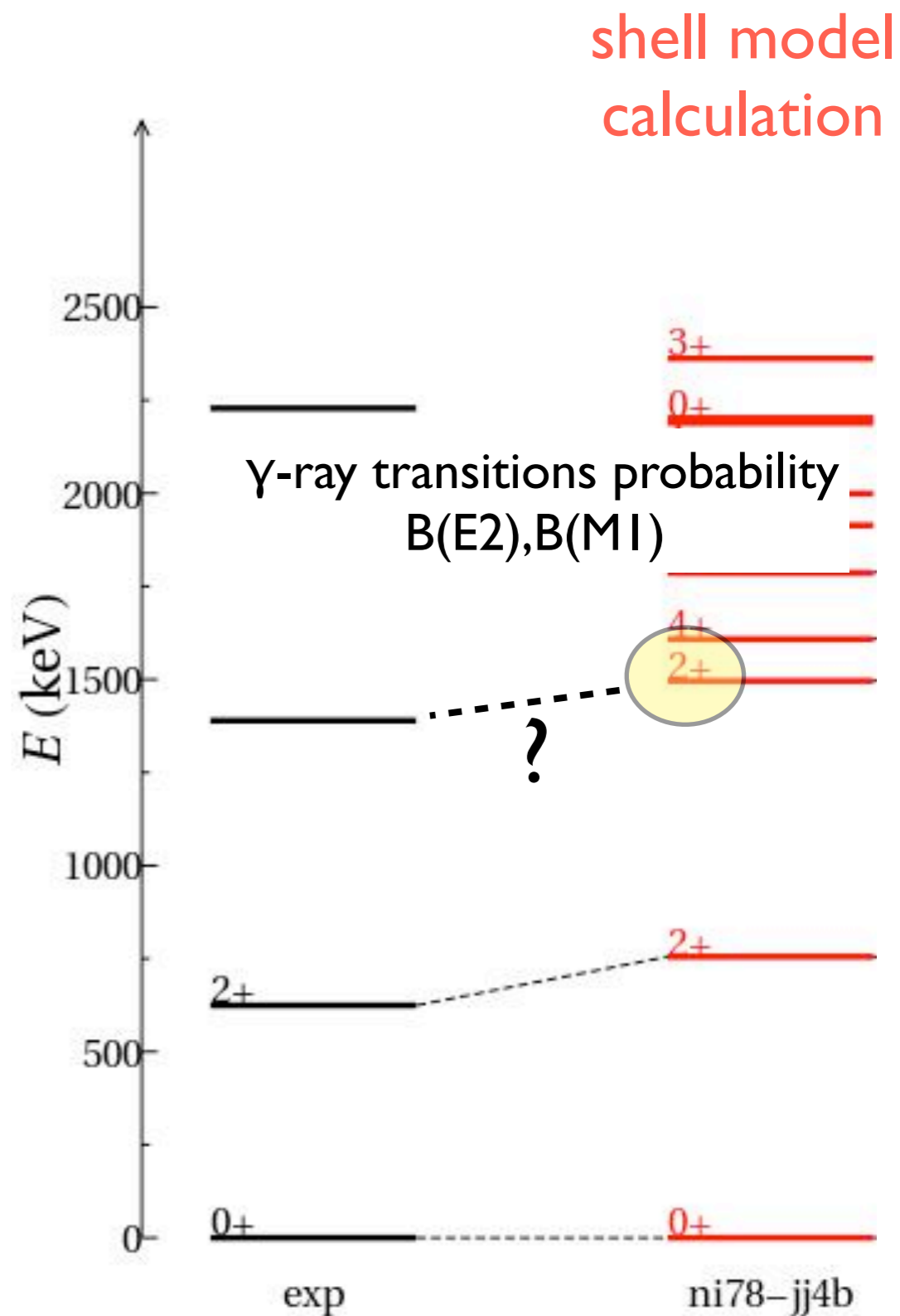
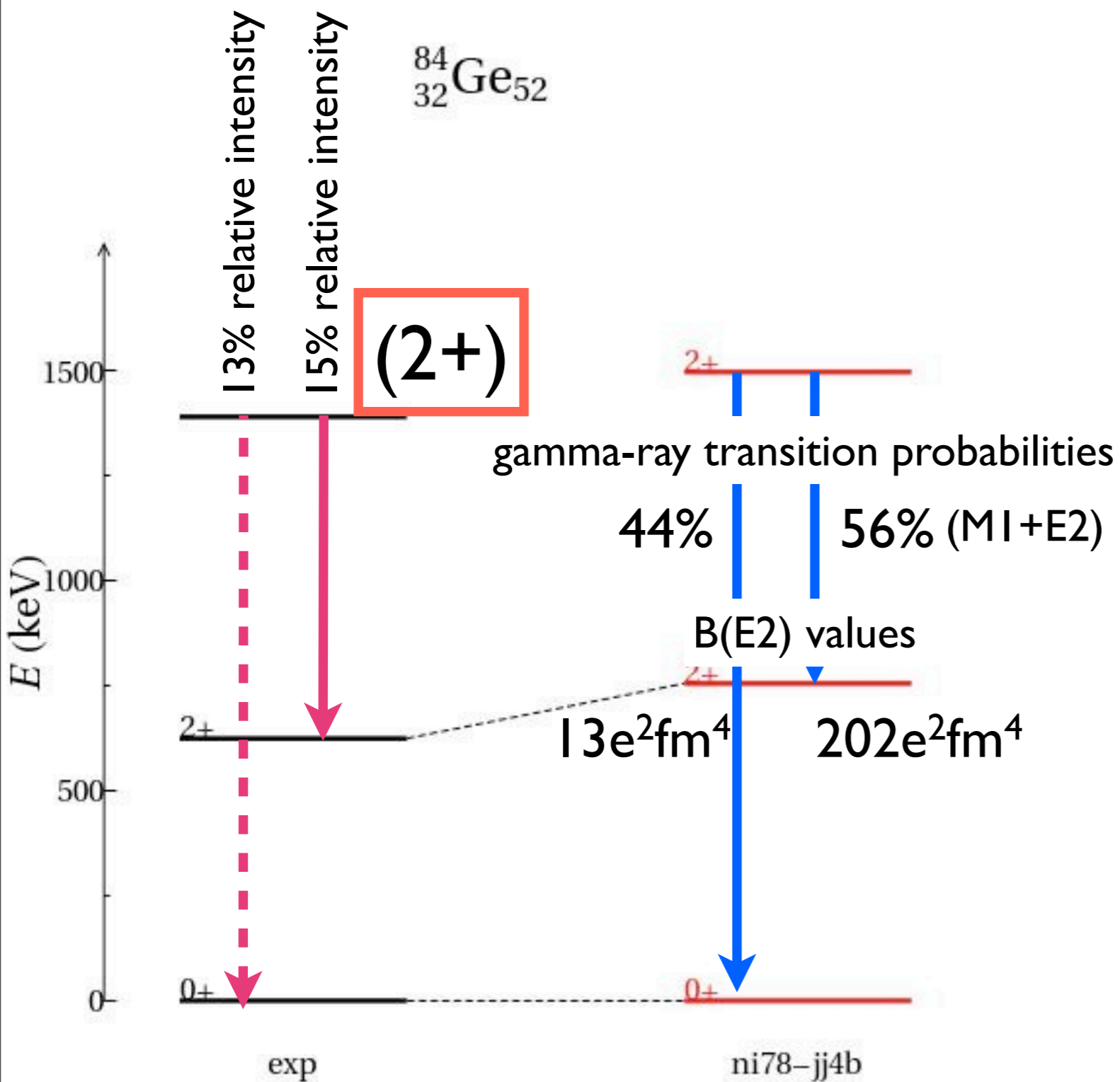

# STRUCTURE OF $^{84}\text{Ge}$ : comparison with $^{80}\text{Ge}$

— d5/2 N=48

50

○—○ g9/2  
V

Z=32

●—● d5/2 N=52

50

— g9/2  
V

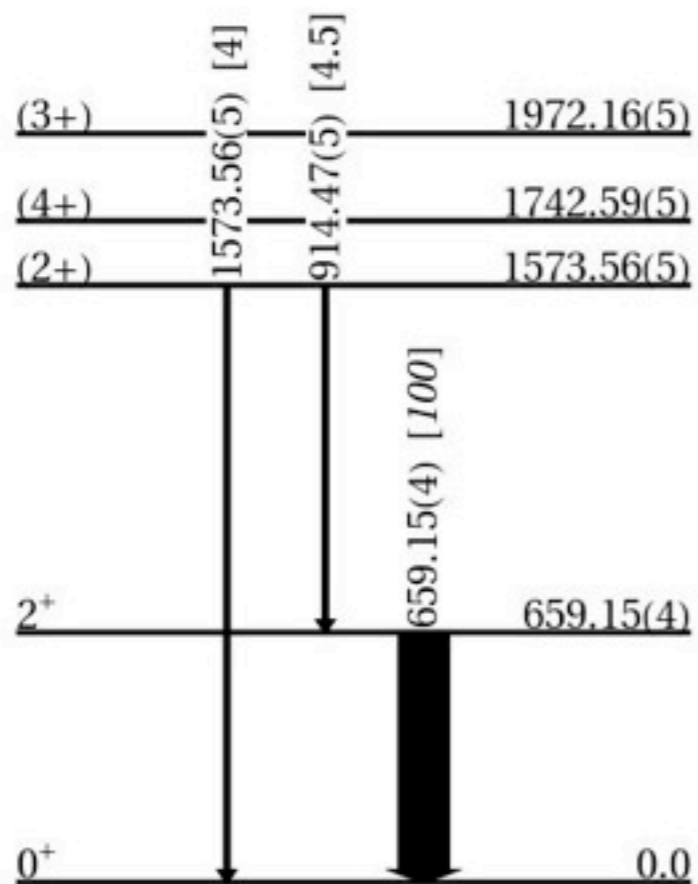

$^{80}_{32}\text{Ge}_{48}$

E [keV]	$^{80}\text{Ge}$	$^{84}\text{Ge}$
$2_1^+$	659	624
$2_2^+$	1573	1389

B(E2)	$^{80}\text{Ge}$	$^{84}\text{Ge}$
$2_1-0_1$	23	13
$2_2-0_1$	200	202

$^{80}\text{Ge}$  B(E2) [ $\text{e}^2\text{fm}^4$ ] values from  
H. Iwasaki PRC 78, 021304(R) (2008)

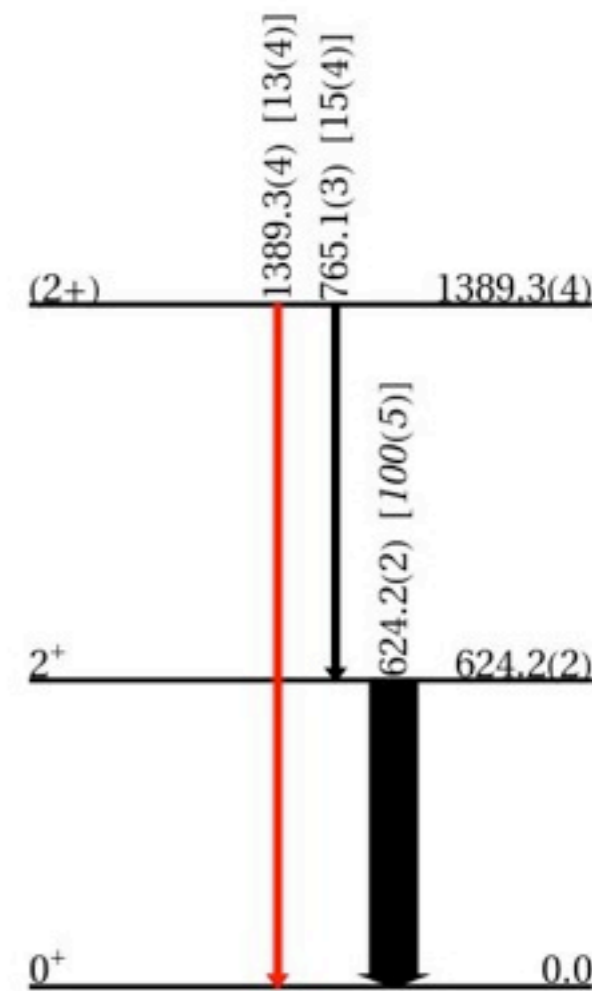

$^{84}_{32}\text{Ge}_{52}$

# STRUCTURE OF $^{84}\text{Ge}$ : comparison with $^{80}\text{Ge}$

— d5/2 N=48

50

○—○ g9/2

V

$$E(2_2^+/2_1^+) = 2.4$$

**gamma deformation**  
**~25°**

(asymmetric rotor model  
Davydov)

$$E(4^+/2^+) = 2.6$$

ax. asym.

0<sup>+</sup> ————— 0.0

$^{80}_{32}\text{Ge}_{48}$

Z=32

●—● d5/2 N=52

50

— g9/2

V

E [keV]	$^{80}\text{Ge}$	$^{84}\text{Ge}$
2 <sub>1</sub> <sup>+</sup>	659	624
2 <sub>2</sub> <sup>+</sup>	1573	1389

B(E2)	$^{80}\text{Ge}$	$^{84}\text{Ge}$
2 <sub>1</sub> -0 <sub>1</sub>	23	13
2 <sub>2</sub> -0 <sub>1</sub>	200	202

$^{80}\text{Ge}$  B(E2) [e<sup>2</sup>fm<sup>4</sup>] values from  
H. Iwasaki PRC 78, 021304(R) (2008)

$$E(2_2^+/2_1^+) = 2.23$$

**gamma deformation**  
**~25°**

$$Q_{\text{spec}}(2_1^+) = -21.5$$

$$Q_{\text{spec}}(2_2^+) = 20.3$$

$$Q_{\text{spec}}(3_1^+) = 0$$

$$B(E2; 3_1^+ - 2_2^+) = 434 \text{ e}^2\text{fm}^4$$

$^{84}_{32}\text{Ge}_{52}$

# STRUCTURE OF $^{84}\text{Ge}$

**Z=32**

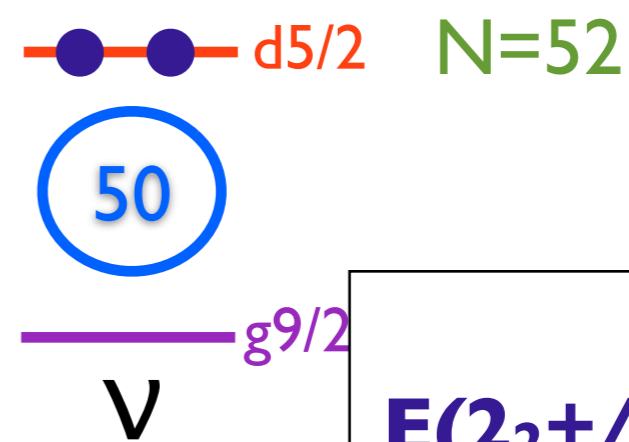
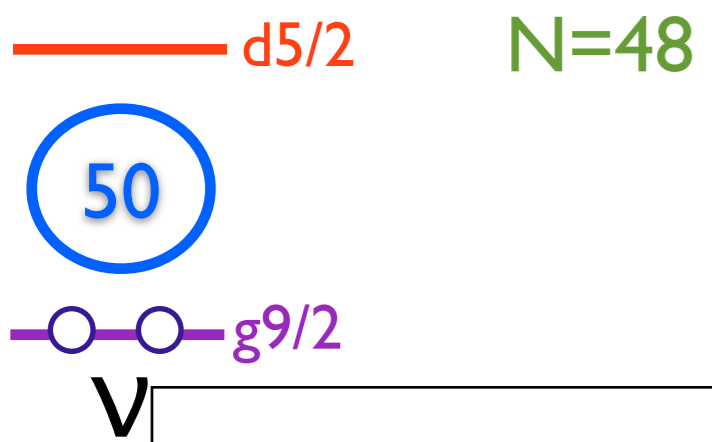

**$E(2_2^+/2_1^+) = 2.4$**   
**gamma deformation**  
 **$\sim 25^\circ$**   
 (asymmetric rotor model Davydov)  
  
 **$E(4^+/2^+) = 2.6$**   
 ax. asym.

E [keV]	$^{80}\text{Ge}$	$^{84}\text{Ge}$
$2_1^+$	659	624
$2_2^+$	1573	1389

**$E(2_2^+/2_1^+) = 2.23$**   
**gamma deformation**  
 **$\sim 25^\circ$**   
  
 $Q_{\text{spec}}(2_1^+) = -21.5$   
 $Q_{\text{spec}}(2_2^+) = 20.3$   
 $Q_{\text{spec}}(3_1^+) = 0$   
  
 $B(E2; 3_1^+ \rightarrow 2_2^+) = 434 \text{ e}^2\text{fm}^4$

gamma band } 

(model dependent) indication of an asymmetric deformation in Ge isotopes

## CONCLUSIONS

---

### **1. Study of $^{84}\text{Ga}$ beta decay**

- **Improve level schemes of  $^{84}\text{Ge}$  and  $^{83}\text{Ge}$**

### **2. Shell Model interaction**

- **description of nuclei in the vicinity of  $^{78}\text{Ni}$**

**what more do we know about “doubly magic”  $^{78}\text{Ni}$ ?**

**-we used it as a core**

**what about  $Z=32$ ?**

- **good example for studying collectivity (already with two neutrons above  $N=50$  indication of gamma deformation)**

**To be done:**

- **interpretation and calculations for  $^{83}\text{Ge}$**

**- FUTURE EXPERIMENTS AT ALTO**

*Thank you for your attention!*

# ORSAY LASER INSTALLATION

first floor

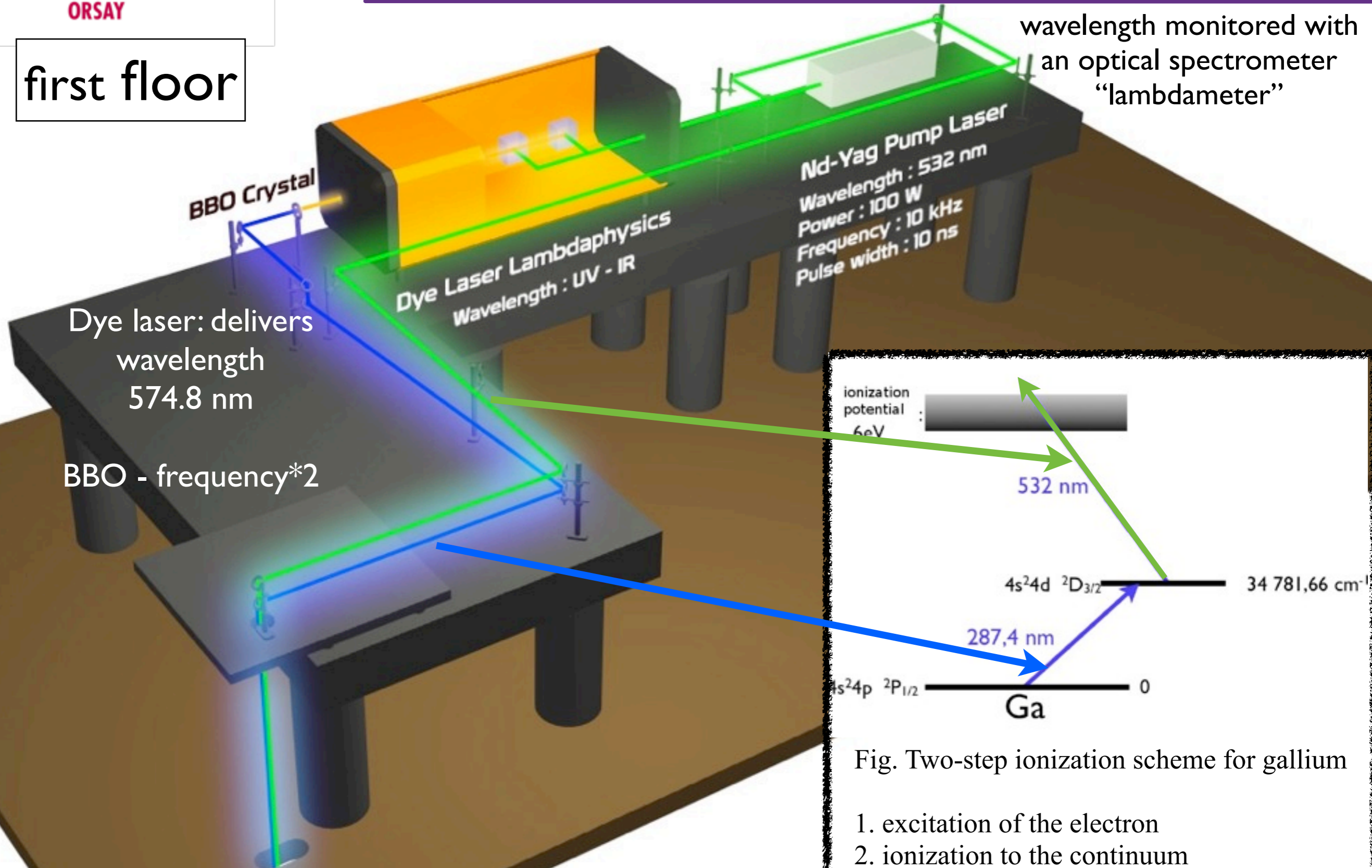
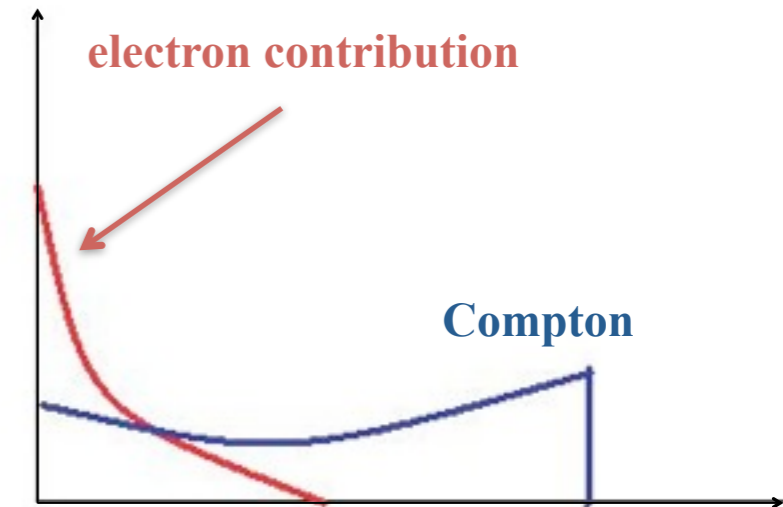
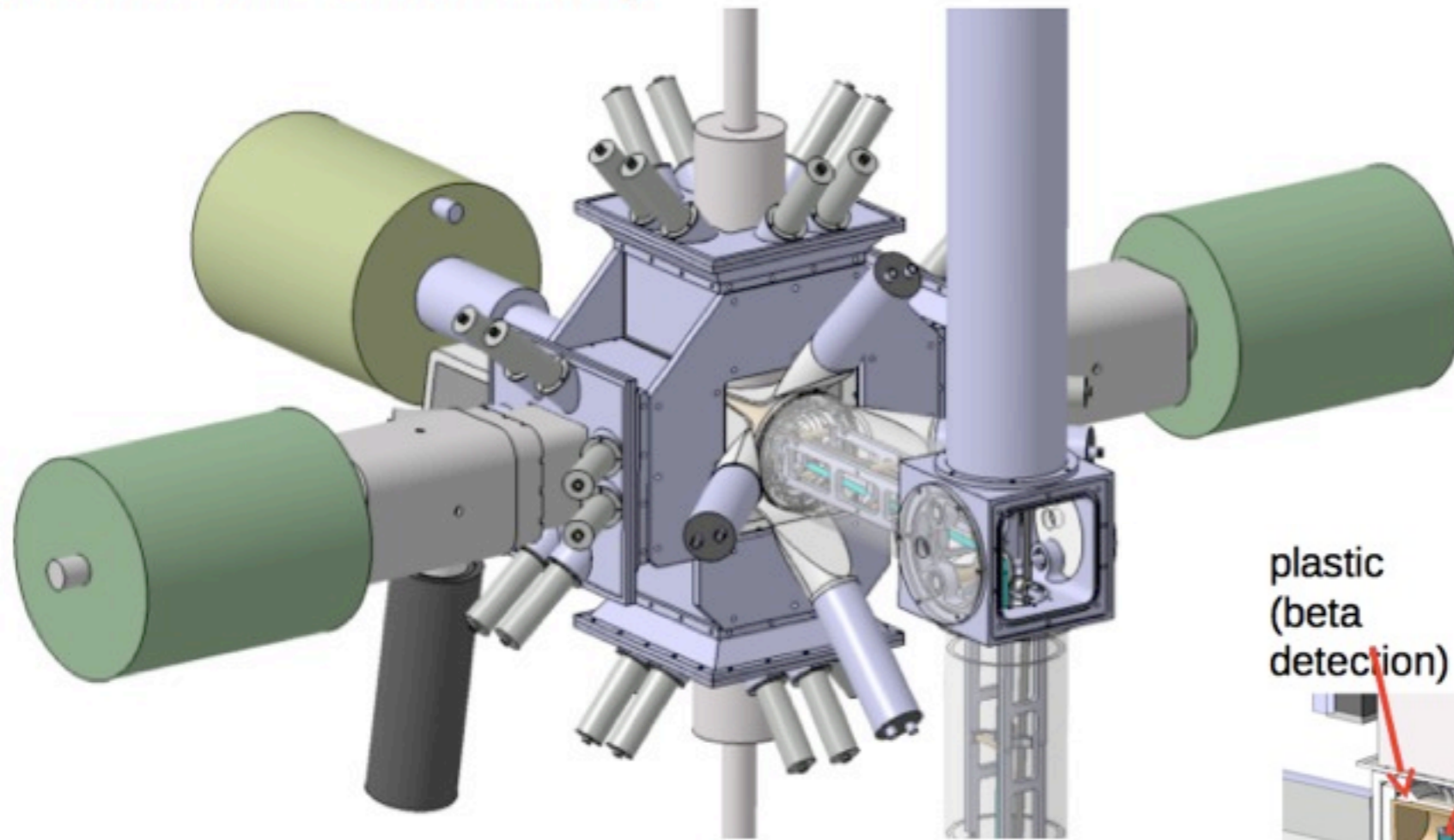

Fig. Two-step ionization scheme for gallium

1. excitation of the electron
2. ionization to the continuum

**goal : increase the sensitivity**



4 EXOGAM small prototypes  
 Source-cap distance = 5 cm  
 evaluated eff (1 MeV) = 5-6 % (previous system 1,5-2,5%)  
 expected sensitivity 0.1 pps

