

# Development of an X-band LLRF prototype for the EuPRAXIA@SPARC\_LAB LINAC

P.D. Meruga, M. Cargnelutti, B. Baričević, Instrumentation Technologies d.o.o., Solkan, Slovenia  
 L. Piersanti, M. Bellaveglia, B. Serenellini, INFN-LNF, Italy  
 A. Mostacci, Sapienza University of Rome, Italy



Doctoral Network

Plasma Accelerators School 2024, Rome, Italy

## ABSTRACT

EuPRAXIA stands for “European Plasma Research Accelerator with eXcellence In Applications”. It's a collaborative project aimed at developing a compact, cost-effective particle accelerator based on plasma technology. This initiative involves researchers and institutions across Europe working together to advance the field of accelerator science. EuPRAXIA aims to produce a new generation of accelerators with potential applications in various fields, including medicine, industry, and fundamental research in physics. LLRF stands for Low-Level Radio Frequency. It's a system used in particle accelerators to stabilize and control the radiofrequency fields used to accelerate charged particles, ensuring precise energy levels and beam stability. The goal of this project is the development of a prototype for an X-band LLRF system, tailored to address the challenging requirements of the EuPRAXIA@SPARC\_LAB application. Once confirmed on a real testbench, the prototype will be used as a starting point for the industrialization into a commercial instrument. This poster will present the Conceptual Block diagram of the LLRF prototype.

## INTRODUCTION

The development of an X-Band LLRF (Low-Level Radio Frequency) prototype marks a significant advancement in the field of accelerator technology. X-Band refers to the microwave frequency range of approximately 8 to 12 gigahertz (GHz), widely utilized in high-energy physics research and medical applications. LLRF systems play a crucial role in maintaining the stability and efficiency of particle accelerators by precisely controlling the radio frequency fields used to accelerate charged particles.

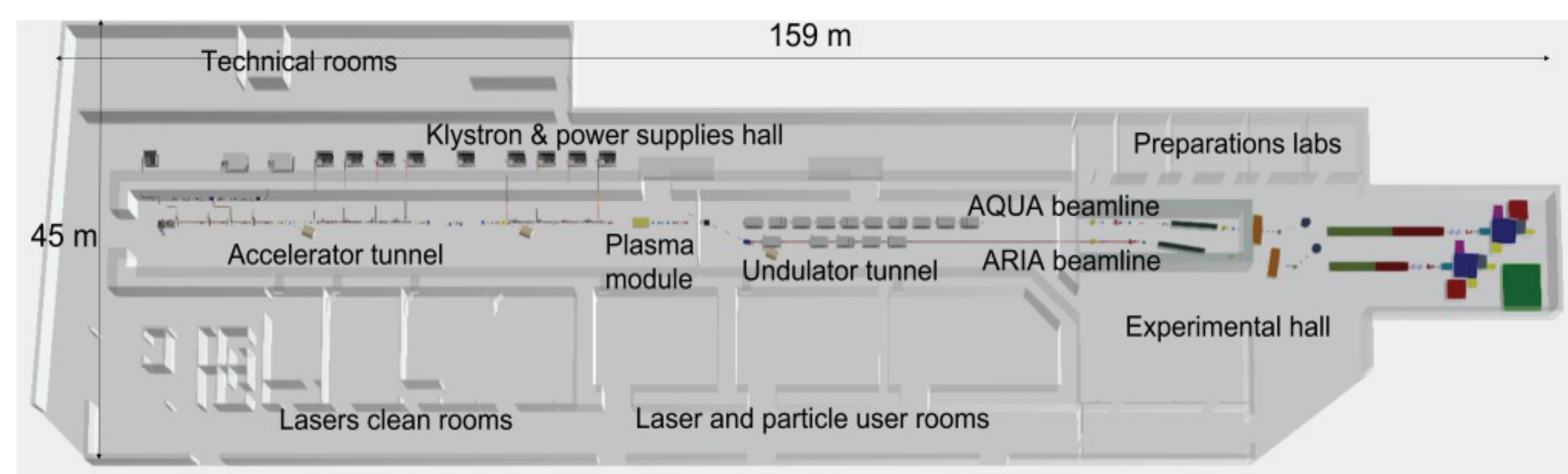

Figure 1: EuPRAXIA@SPARC\_LAB machine layout

Parameter	Desired value
Mode of operation	Pulsed
Carrier frequency	11.994 GHz
Back-end BW	> 80 MHz
Back-end output level	> 10 dBm
Front-end BW	> 25 MHz
Front-end max. input level	20 dBm
Sampling rate	≥ 250 MS/s
Time window	≥ 3 us
RF pulse max. repetition rate	≥ 400 Hz
Minimum pulse-to-pulse detectable amplitude jitter (front end)	< 0.05% rms
Minimum pulse-to-pulse detectable phase jitter (front end)	< 0.015 deg rms (@ 11.994 GHz)
Vector Modulator pulse-to-pulse added amplitude jitter	< 0.05% rms
Vector Modulator pulse-to-pulse added phase jitter	< 0.015 deg rms (@ 11.994 GHz)
n. RF input ch. for LLRF prototype	≥ 2
n. RF output ch.	1
Pulse shaping (amplitude & phase) of vector modulator output	Arbitrary (from spreadsheet)

Figure 2: LLRF Prototype Preliminary Requirements

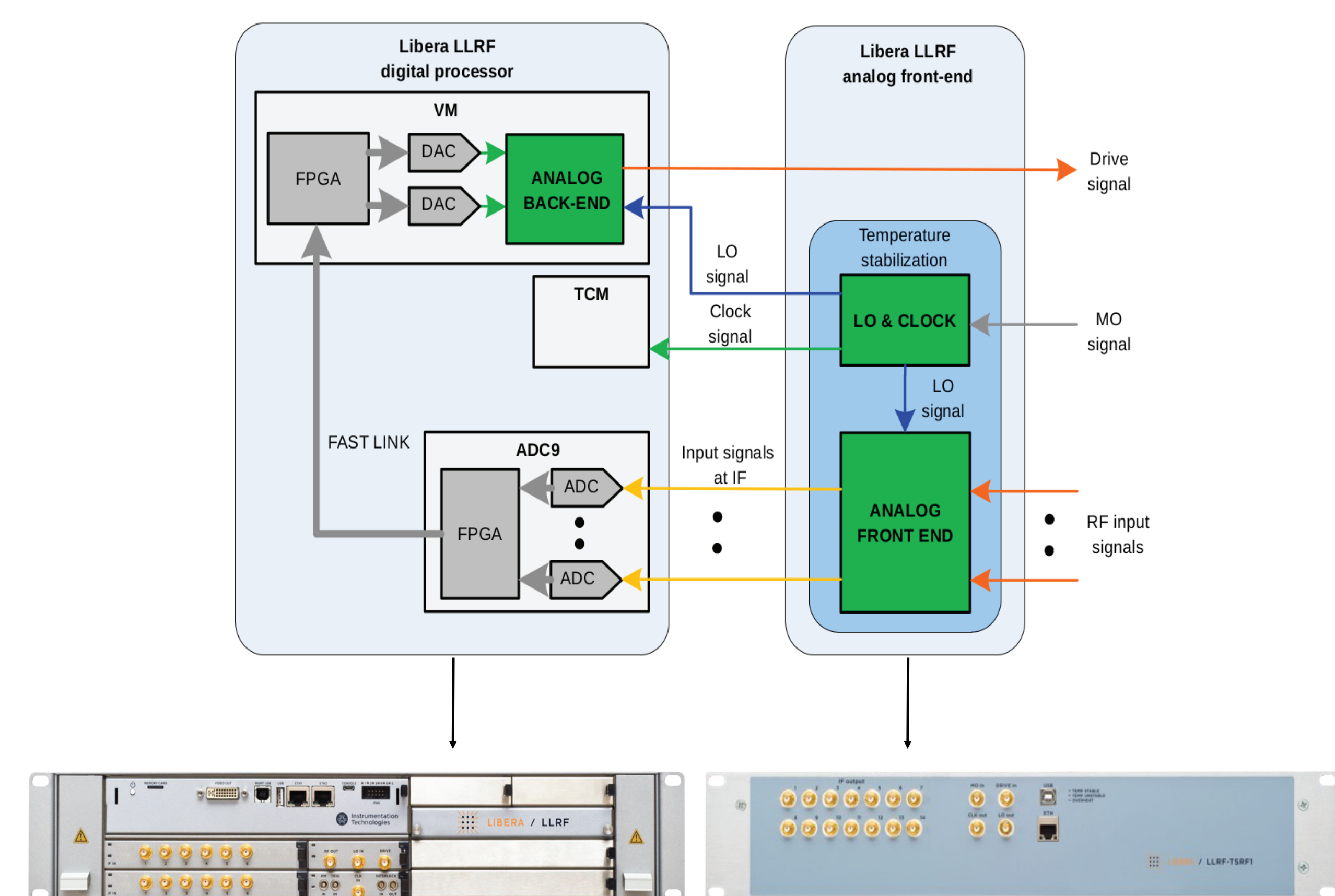

Figure 3: LIBERA LLRF Instrument

## CONCEPTUAL BLOCK DIAGRAM

The Block diagram explains the designed approach of the X-Band LLRF prototype and also the synthesis of LO and ADC signals. Single stage down-conversion and a double stage up-conversion scheme is considered and employed.

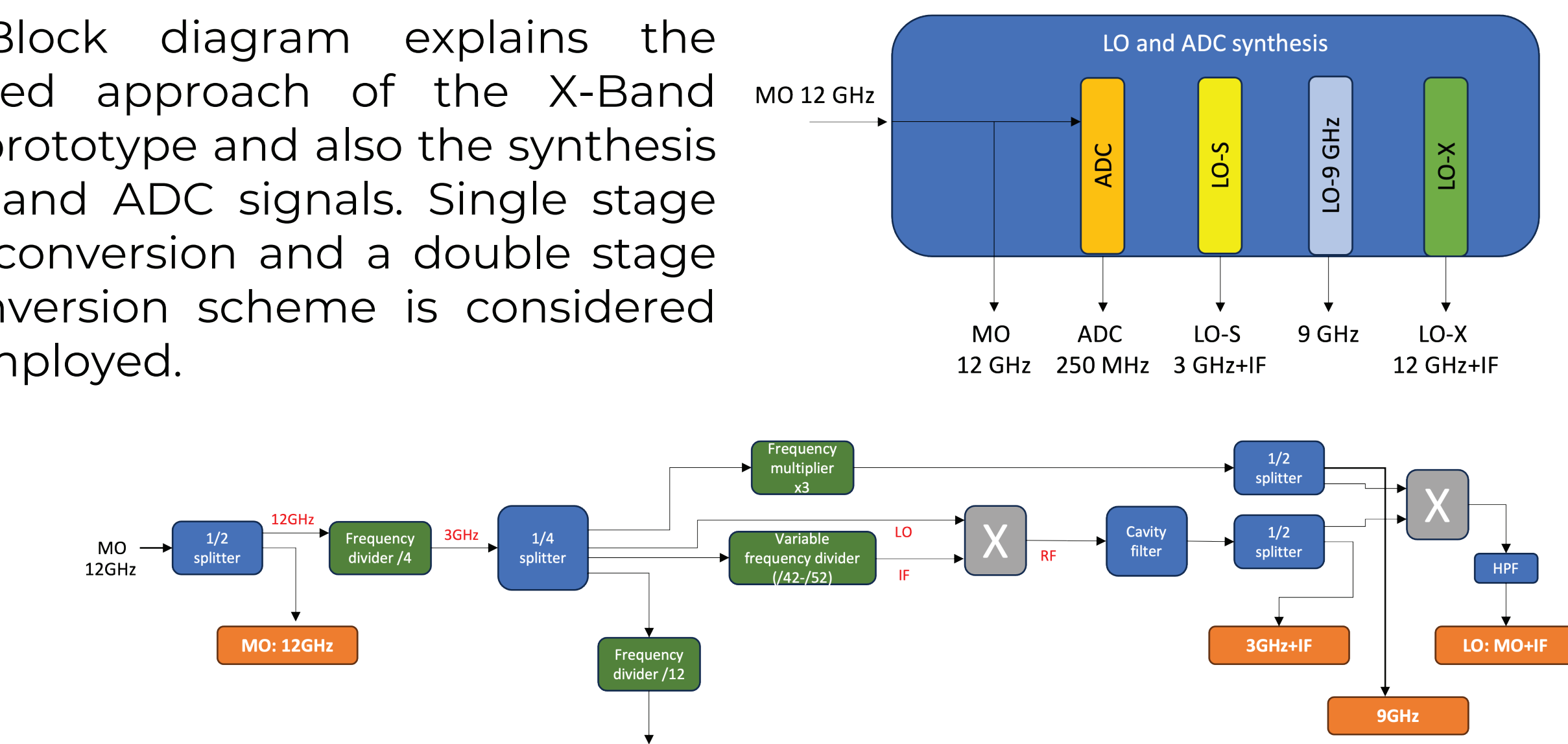

Figure 4: Architecture of LO and ADC synthesis block

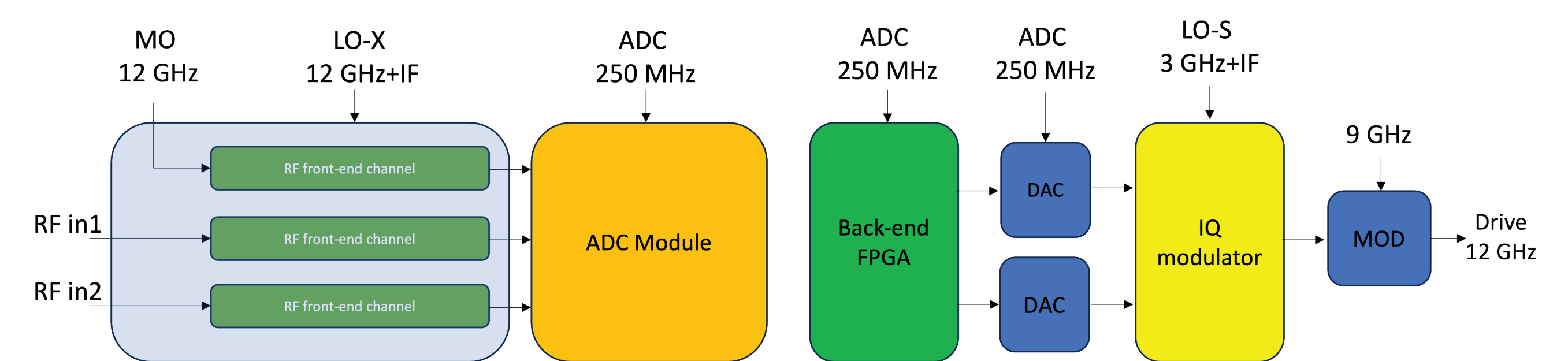

Figure 5: Prototype conceptual block-diagram

## MEASUREMENT SET-UP

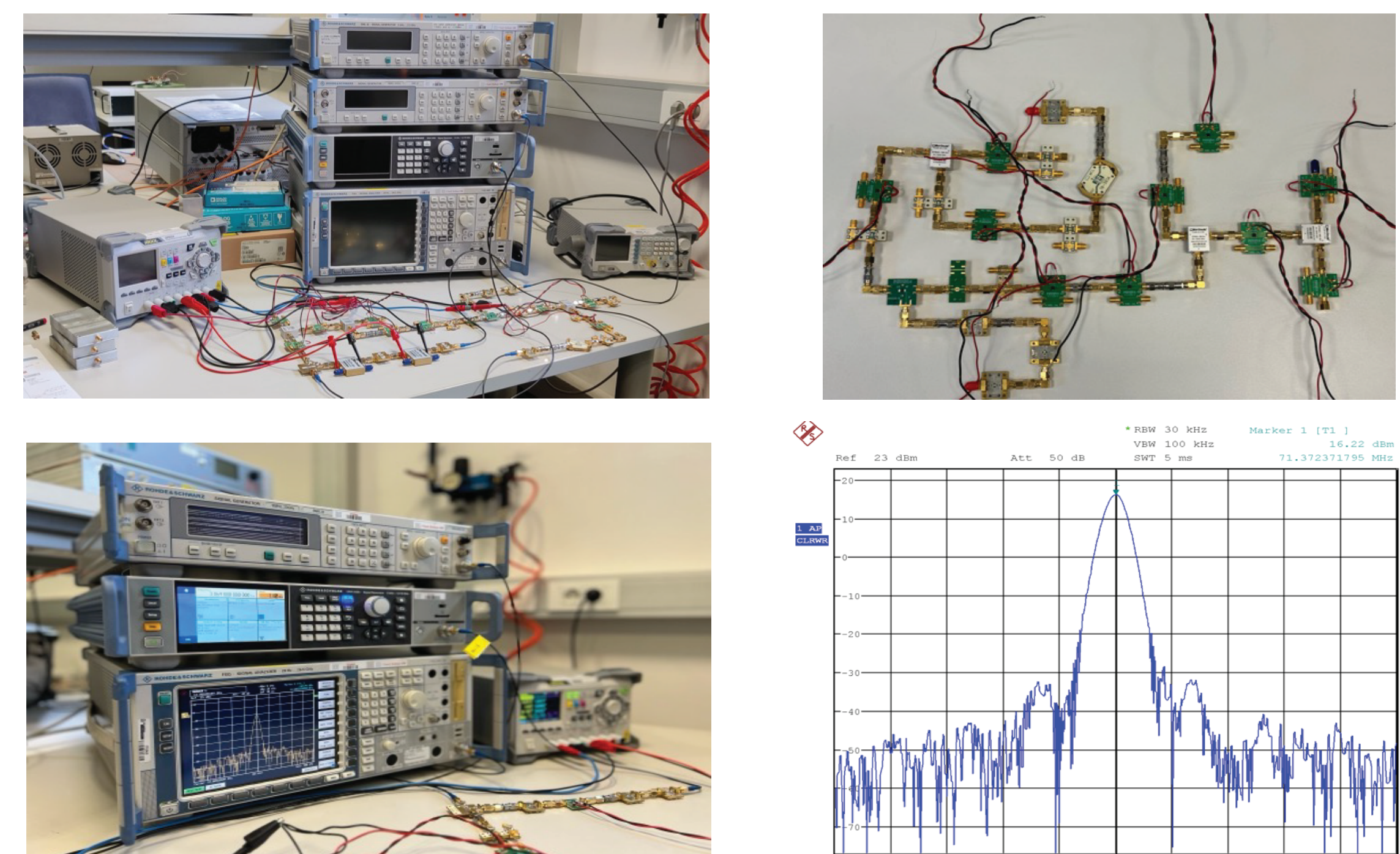

Figure 6: Laboratory Analysis of RF components in a chain

## CAVITY FILTER ANALYSIS

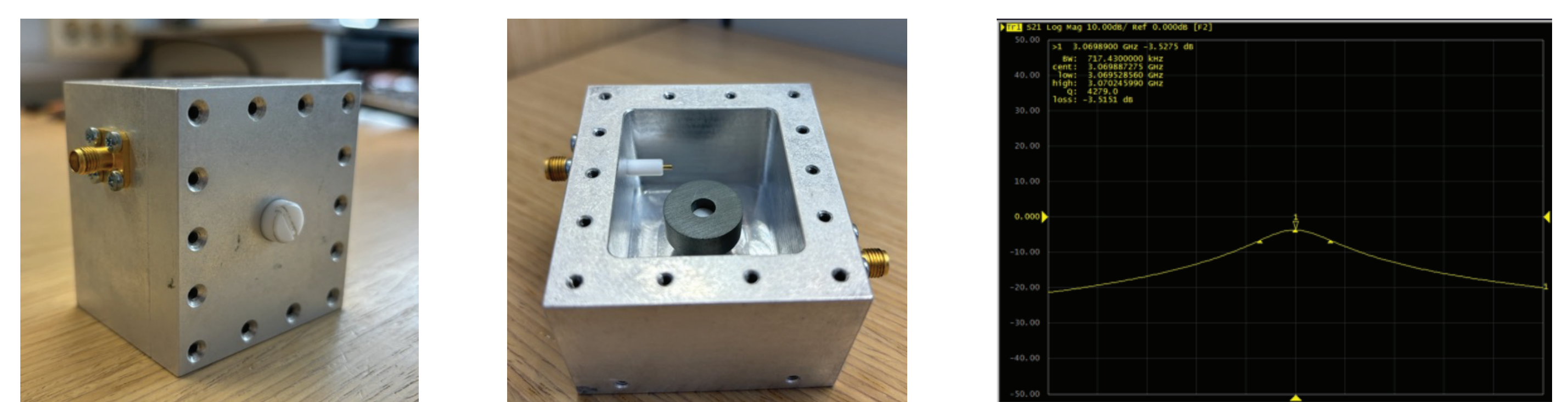

Figure 7: 3GHz Cavity Filter response ( $S_{21}$ )

## OUTLOOK & CONCLUSIONS

Next step would be to verify and assemble the prototype in a chassis and evaluate the performance of the prototype through phase noise measurements. The successful realization of an X-Band LLRF prototype holds the promise of revolutionizing the landscape of particle accelerator technology, ushering in a new era of unprecedented performance and reliability.