

Exploring Eco-Friendly Gas Mixtures for Resistive Plate Chambers: A Comprehensive Study on Performance and Aging

Luca Quaglia¹ on behalf of the RPC ECOgas@GIF++ collaboration

¹INFN Torino

Overview

- Resistive Plate Chambers (RPCs) at the LHC
- Currently employed gas mixture and environmental issues
 - HFO+CO₂ as a possible alternative
- Test set-up at the CERN GIF++
 - The RPC ECOgas@GIF++ collaboration
- Aging studies HFO-based gas mixtures
 - Methodology
 - Results
- 2022 vs 2023 beam test comparison (a first look)
- Conclusions and outlook

RPCs at the LHC

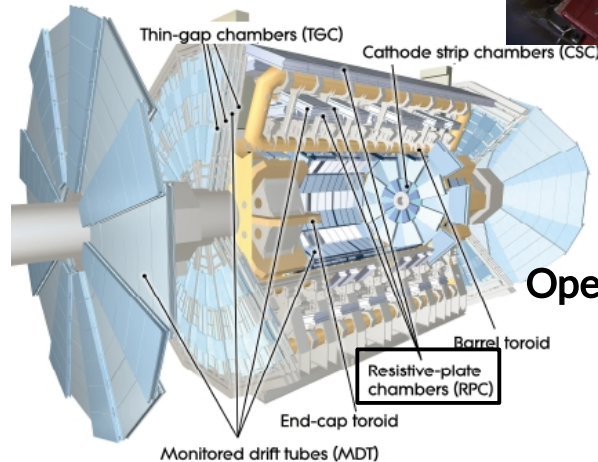

ATLAS RPCs
Operated during Run1/2 + installation of
new RPCs for HL-LHC (BIS7/8)
~ 4000 m²

The currently employed gas mixture

- RPC working parameters depend on the gas mixture employed
- The currently-used gas mixtures at the LHC grant the following properties:
 - 1) High density of primary ion-electron pairs
 - 2) Relevant quenching properties
→ Ability of capturing recombination photons without further ionization
 - 3) Enough electron affinity to capture free electrons, reducing the spatial size of the discharge

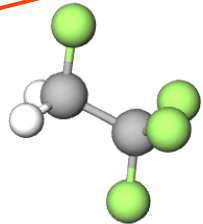

$C_2H_2F_4$ (R-134a): provides primary electrons

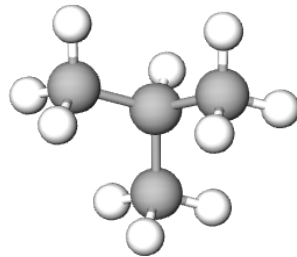

$i-C_4H_{10}$ - isobutane: quenching gas

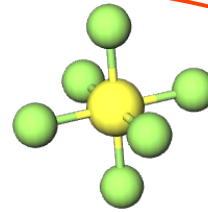

SF_6 - sulfur hexafluoride: electronegative gas

Currently employed gas mixtures consist of these gases in different proportions

The need for a new RPC gas mixture

- All currently employed RPC gas mixtures contain different fractions of R134a and SF₆
→ Fluorinated greenhouse gases (F-gases)
- New EU regulations [1] to reduce the impact of F-gases

- Phase down of the production and consumption of F-gases
- Ban of the gases if a more eco-friendly alternative is available
- Reduction of emissions from existing equipment

Increase in cost and reduction in availability

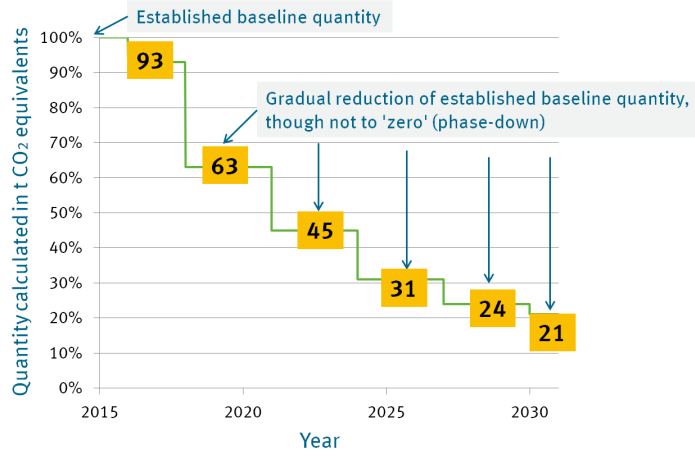

F-gases phase down plan

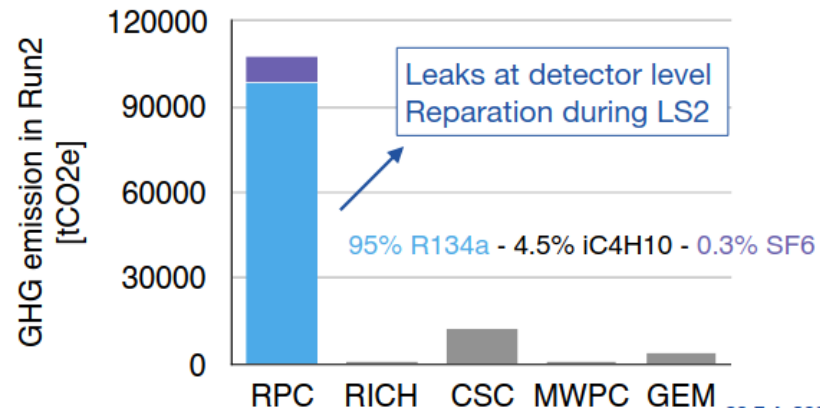

Emission of greenhouse gases from CERN - B. Mandelli VCI 2022

- RPC systems are the main consumer of F-gases at CERN
→ Need to find a more eco-friendly gas mixture

A possible solution

- First efforts of LHC RPC groups focused on R134a replacement
- **Industrial use:** from **R134a** to **hydro-fluoro-olefine** (HFO) family of gases
 - Similar chemical structure as R134a with a double C=C bond
 - Among all HFOs, HFO-1234yf and HFO-1234ze are currently used

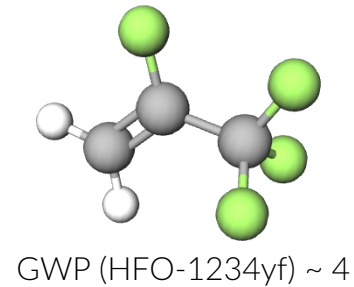
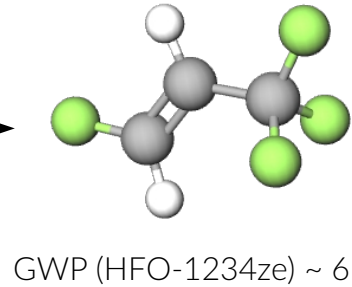
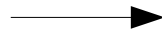
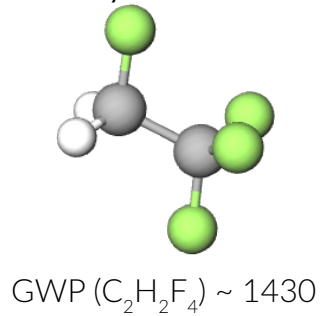

A possible solution

- First efforts of LHC RPC groups focused on R134a replacement
- **Industrial use:** from **R134a** to **hydro-fluoro-olefine** (HFO) family of gases
 - Similar chemical structure as R134a with a double C=C bond
 - Among all HFOs, HFO-1234yf and HFO-1234ze are currently used

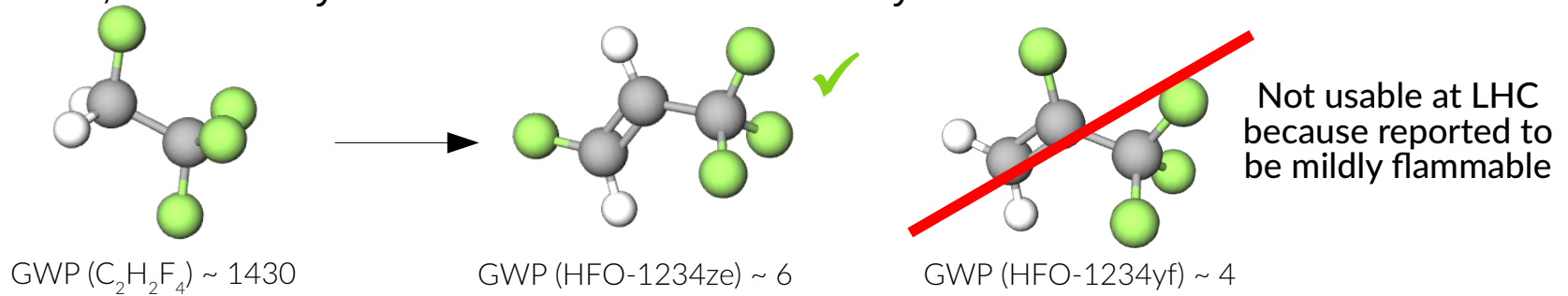

A possible solution

- First efforts of LHC RPC groups focused on R134a replacement
- **Industrial use:** from **R134a** to **hydro-fluoro-olefine** (HFO) family of gases
 - Similar chemical structure as R134a with a double C=C bond
 - Among all HFOs, HFO-1234yf and HFO-1234ze are currently used

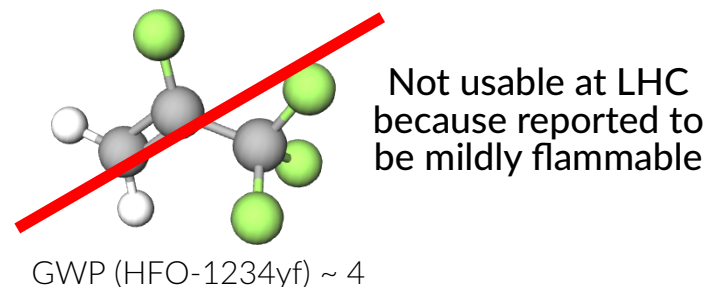
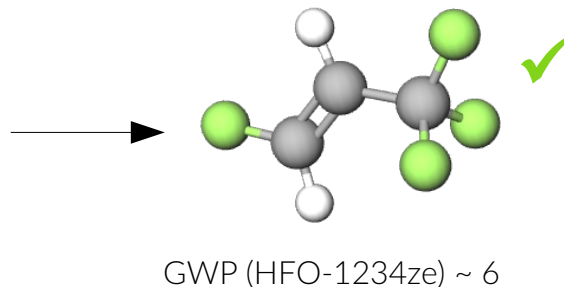
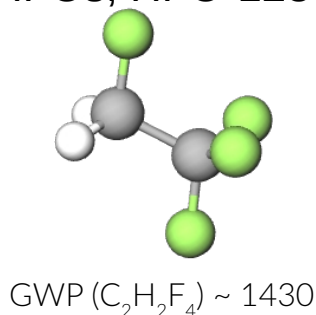

- 1:1 replacement of R134a with HFO not possible
 - Lower first Townsend coefficient
 - Working voltage of the detectors moves to over 15 kV
- HFO has to be diluted with other gases
 - Studies with cosmic muons by different LHC RPC groups [2-5]
 - CO₂ found to be the most promising candidate for dilution
 - **In-depth studies on RPCs long-term behavior with eco-friendly alternatives needed**

Main subject of this presentation

The RPC ECOGas@GIF++ collaboration

- Cross-experiment collaboration to join forces and perform aging/beam test studies with eco-friendly gas mixtures for RPCs
→ Includes CMS, ALICE, ATLAS, SHiP/LHCb and the detector technology group of CERN
- Studies carried out at the CERN Gamma Irradiation Facility (GIF++)
→ Experimental facility located on the H4 secondary SPS beam line
- **12.5 TBq ^{137}Cs source**, high activity allows one to simulate long operating periods in much shorter time spans (**aging studies**) – irradiation can be modulated by means of attenuation filters (absorption factors)
- **High energy** (~ 150 GeV/c) **muon beam** in dedicated **beam time periods**

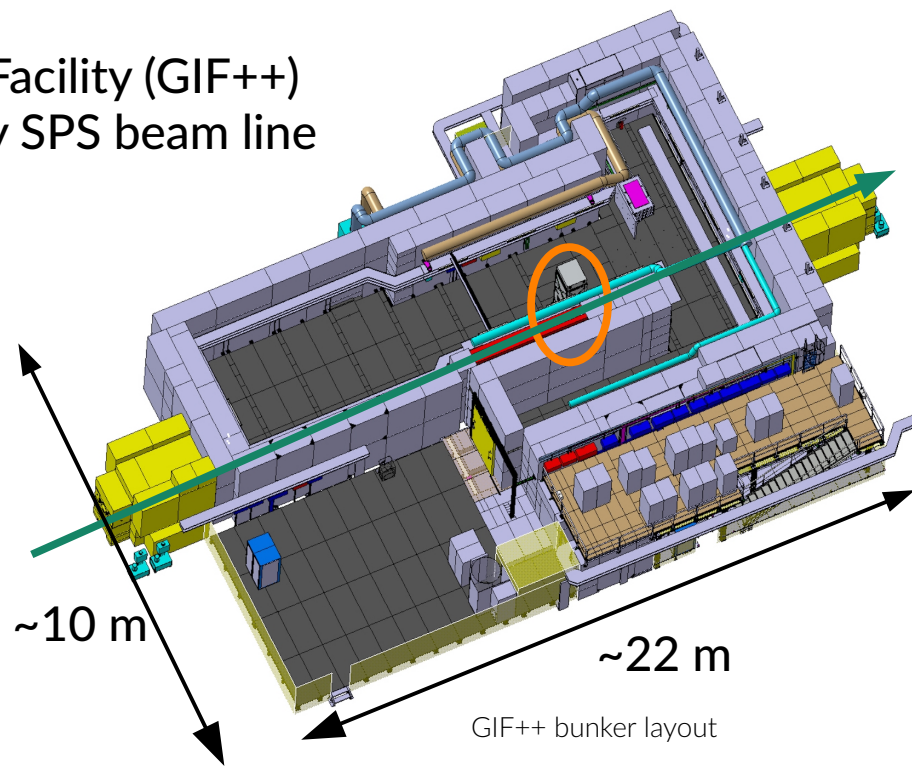

Experimental setup – aging studies

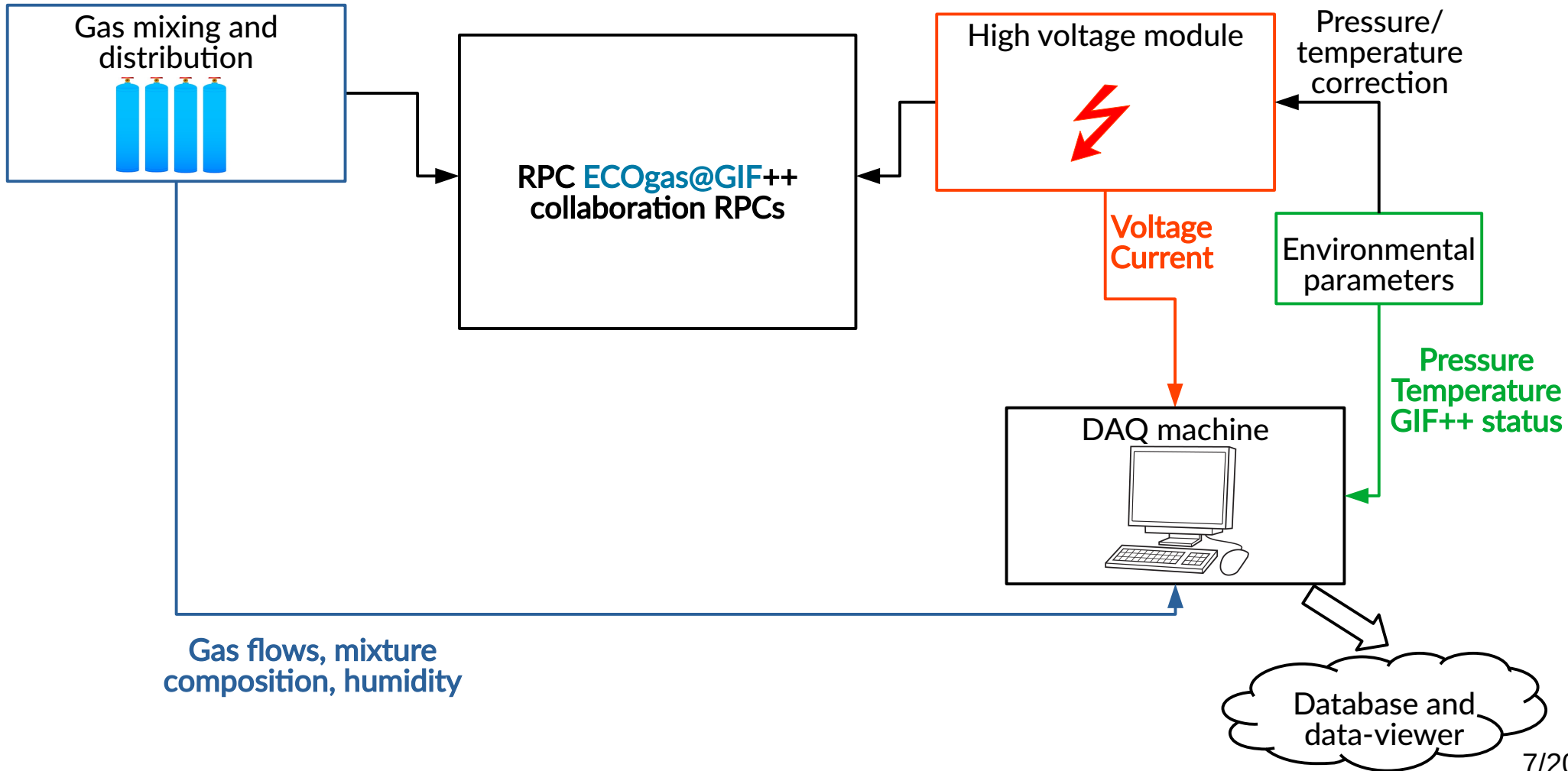

Experimental setup – beam tests

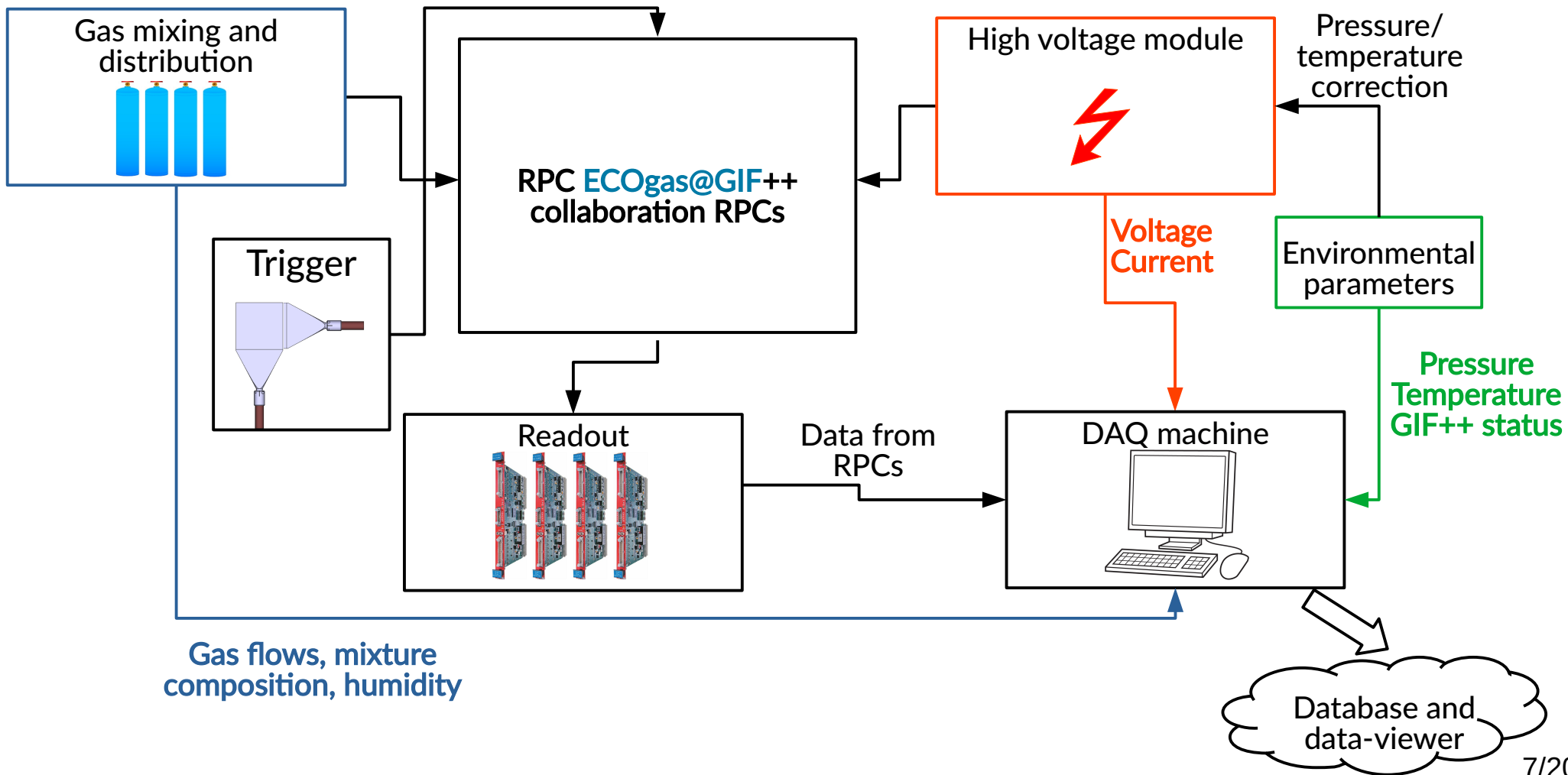

Detectors and gas mixtures

- Each group provided one detector prototype
→ Installed on a common mechanical support in the GIF++ bunker

Detector	# of gaps	Gap thickness (mm)	Electrode thickness (mm)	Gap area (cm ²)
ALICE	1	2	2	2500
ATLAS	1	2	1.8	550
EP-DT	1	2	2	7000
CMS	2 (TW/TN + BOT)	2	2	3637 + 4215
LHCb/SHiP	1	1.6	1.6	7000

- Aging-tested gas mixtures

Name	R134a (%)	HFO (%)	CO ₂ (%)	I-C ₄ H ₁₀ (%)	SF ₆ (%)
STD (reference)	95.2	0	0	4.5	0.3
ECO1	0	45	50	4	1
ECO2	0	35	60	4	1

} With 40% relative humidity added

Aging studies methodology - 1

- High voltage (HV) is switched ON to a fixed value (irradiation voltage)
- Correction for temperature and pressure variations [6] applied every minute
 - To maintain a constant effective high voltage applied
- The detectors are exposed to the γ flux from the ^{137}Cs source
 - Absorbed current and applied HV are logged every 30 seconds
 - Study of absorbed current stability over time
- Once a week the source is fully shielded (*source-off*)
 - HV scan to measure absorbed current without irradiation (dark current)
 - Extract Ohmic component of dark current (see next slides) for integrated charge calculation
- Periodic (2/3 times per year) beam test campaign to monitor RPC performance evolution

Aging studies methodology - 2

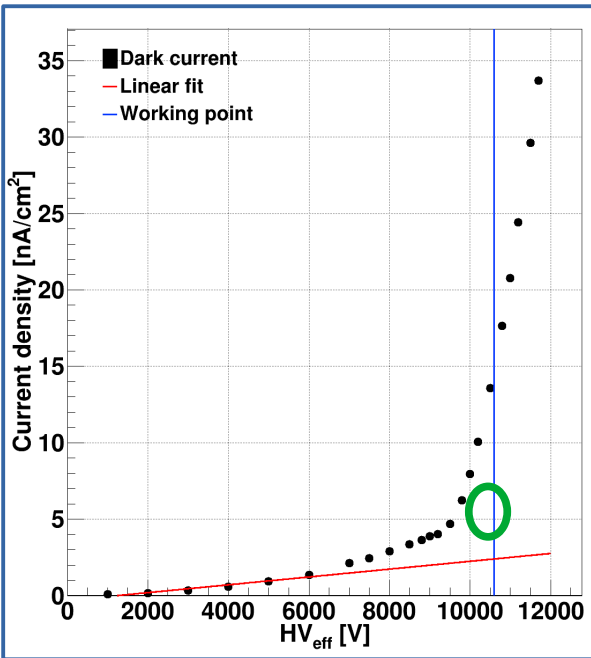

- Example of dark current scan vs effective high voltage
- One scan per week during the aging studies
- Linear fit between 0 and 5 kV to extrapolate **Ohmic component of the dark current at the irradiation voltage**
 - This current does not flow though the gas
 - Subtracted from the current absorbed under irradiation to calculate the integrated charge

- Trend of monitored current (fixed HV) as a function of time
- Blue curve = total current
- Red curve = total current minus Ohmic component of dark current
- Weekly source-off scans allow to subtract Ohmic current each week
- HV scans during aging studies = change in absorbed current

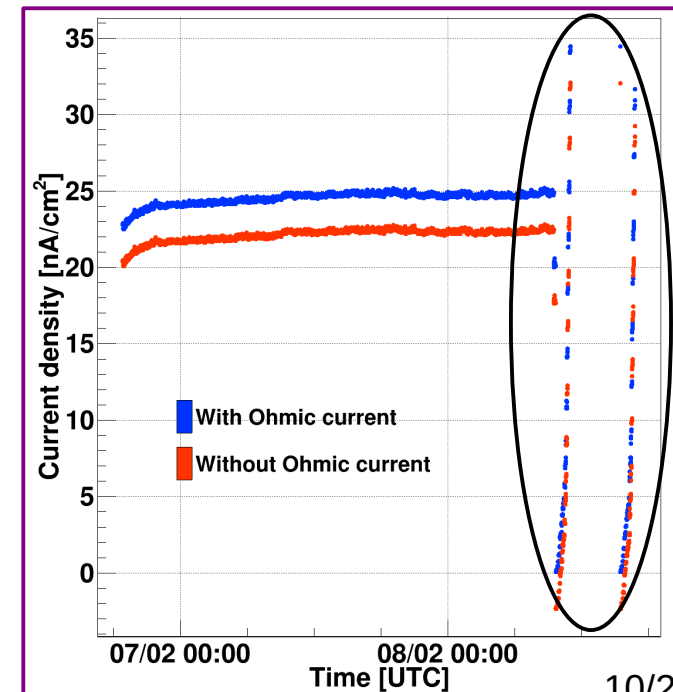

Aging studies results – ECO1

ALICE RPC
2 mm gap
~6 m from source

- Preliminary aging campaign with the currently employed gas mixture (STD) to test stability of the system
- First eco-friendly candidate tested: ECO1 (50% CO₂ and 45% HFO)
- **In general:** higher currents wrt STD gas mixture

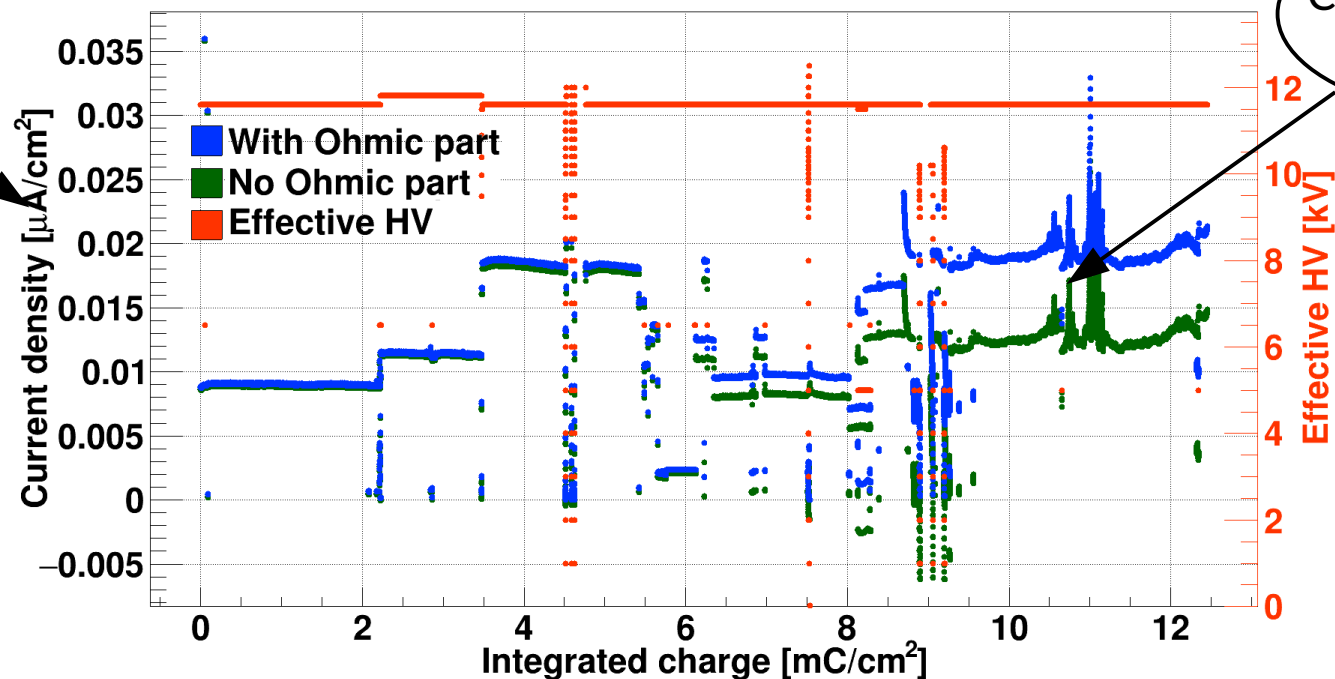

Monitored current with and without Ohmic component of the dark current

Current instabilities + increase of Ohmic dark current

Stability of effective HV

Reported as a function of the integrated charge
→ Integral of absorbed current (without Ohmic part) over time
→ Irradiation is not always ongoing and there would be empty regions in the plot

Aging studies results – ECO1

ALICE (2 mm)
CMS GT (2 mm)

- Together with increase of current under irradiation
→ Increase of dark current (total and Ohmic)
- These figures show the dark current at irradiation voltage (total and Ohmic)

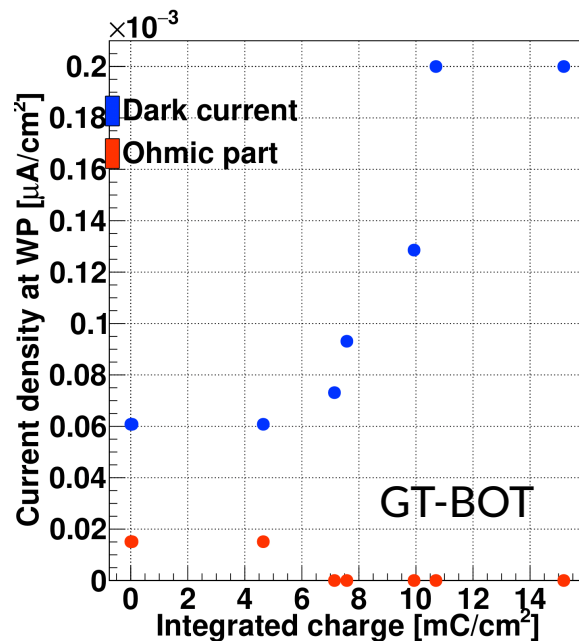
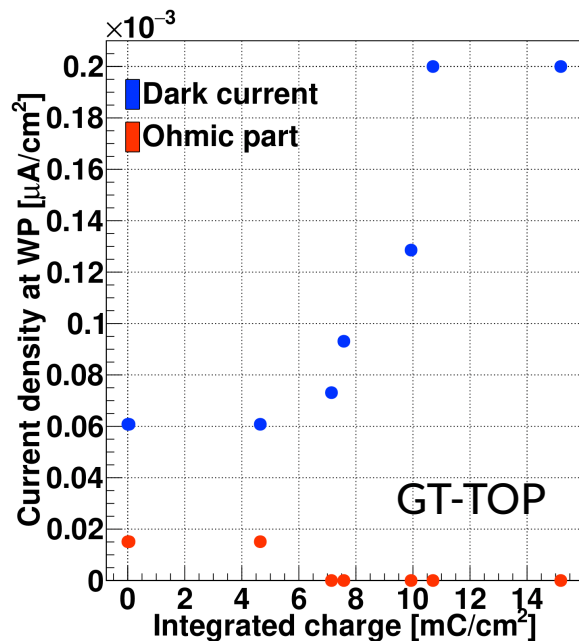

Same figure for ALICE

- Similar increase observed in all detectors of the collaboration
→ Decided to discard this mixture and test a new one
- Reduced HFO content to lower the detector working voltage

Aging studies results – ECO2

CMS RPC
2 mm gap
3 m from source

- Second eco-friendly candidate tested: ECO1 (60% CO₂ and 35% HFO)

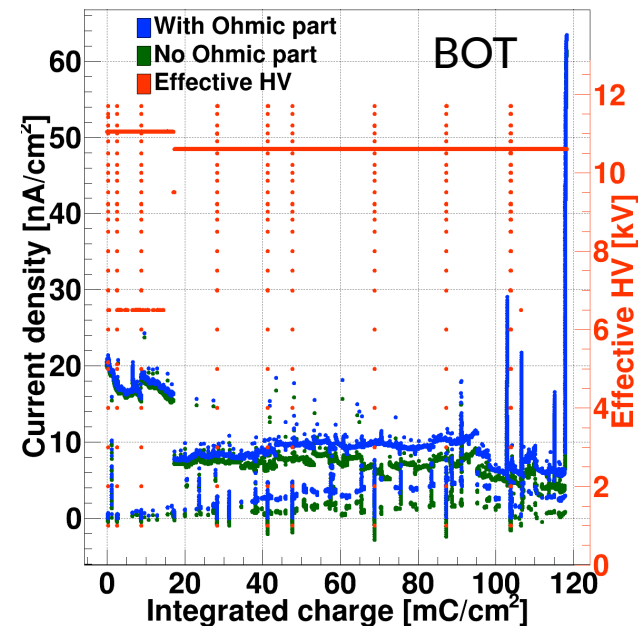
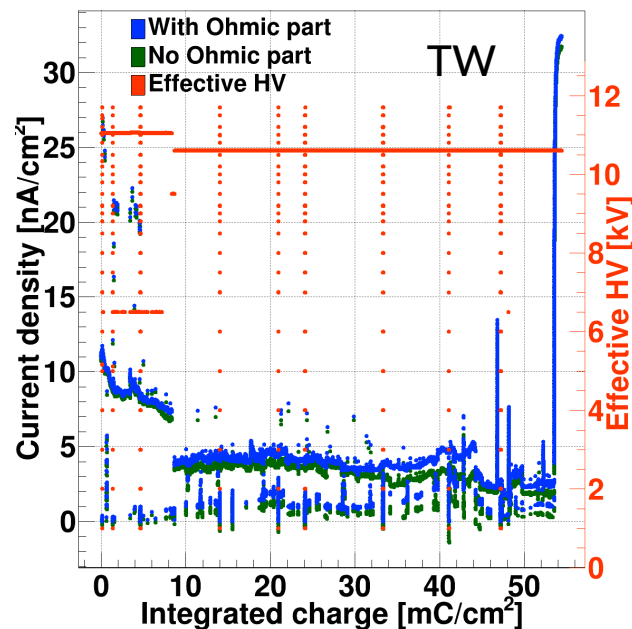
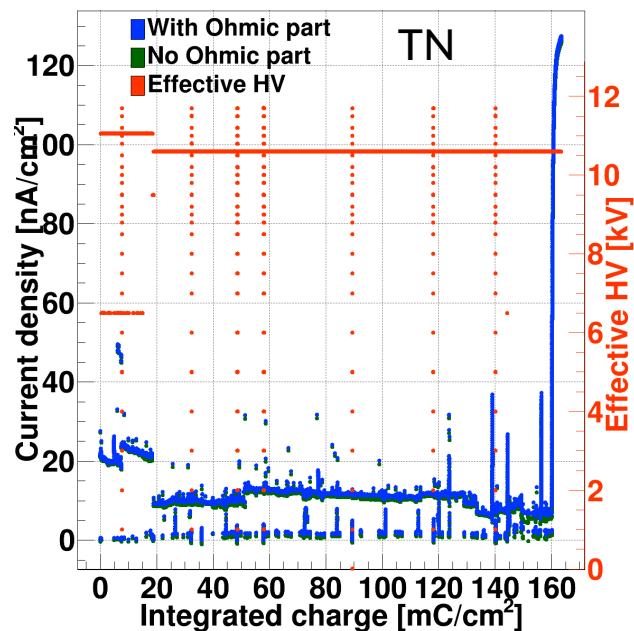

- Irradiation voltage set to 10.6 kV
→ Source OFF knee to limit the absorbed current for long periods of time
- Most of the irradiation the ABS is 2.2 (~500 Hz/cm² background rate)
- Stability of absorbed current over time

Aging studies results – ECO2

- Total and Ohmic dark currents at working point vs integrated charge

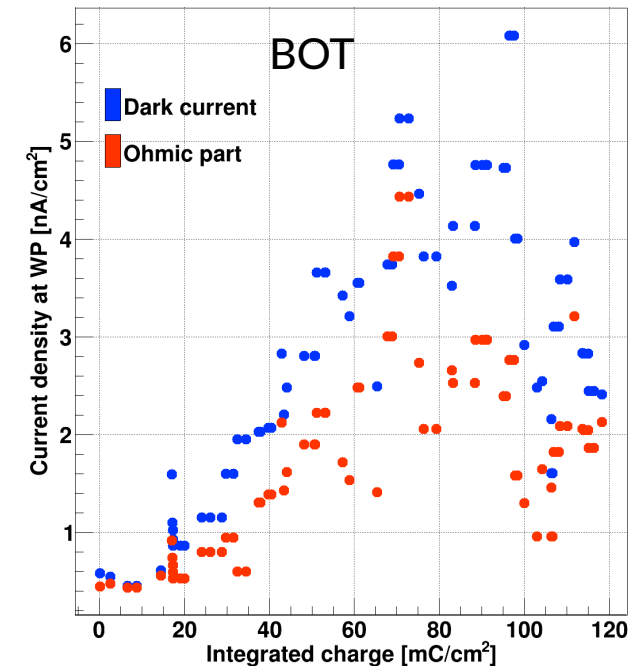
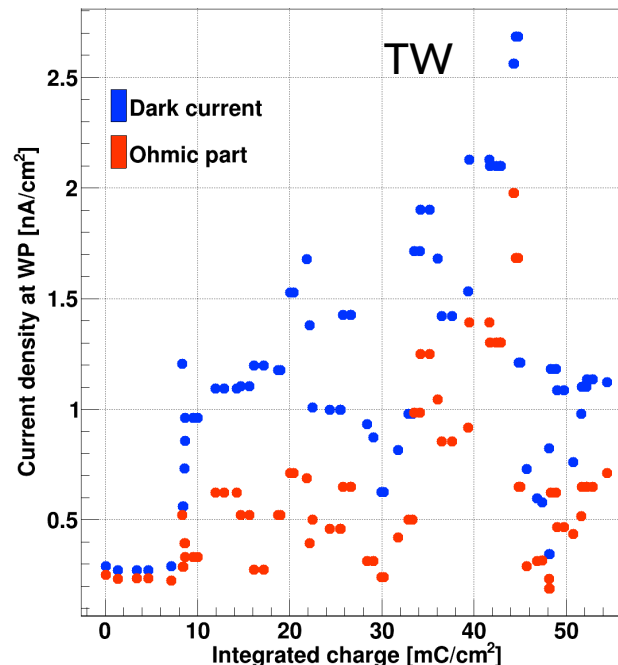
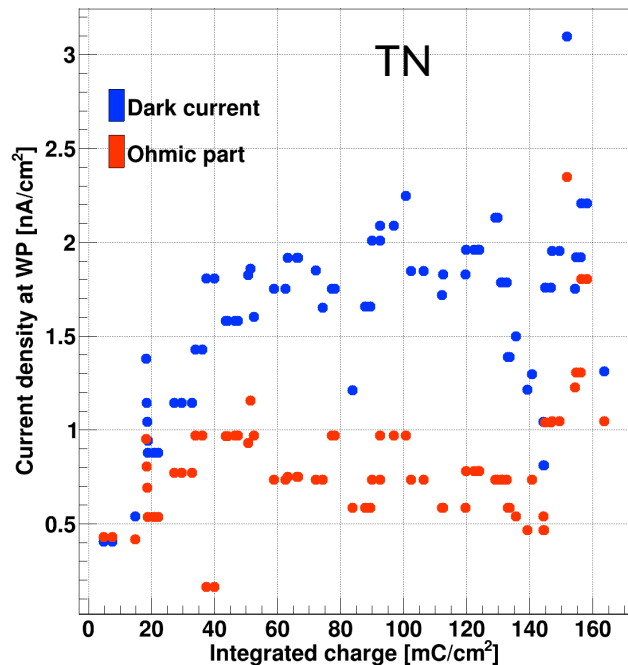

- After initial increase
→ Stable for TN and TW
- Increasing and decreasing trend for BOT
- Not clear behavior observed, under investigation

Aging studies results – ECO2

- Results for a thinner gap RPC (ShiP/LHCb, 1.6 mm)

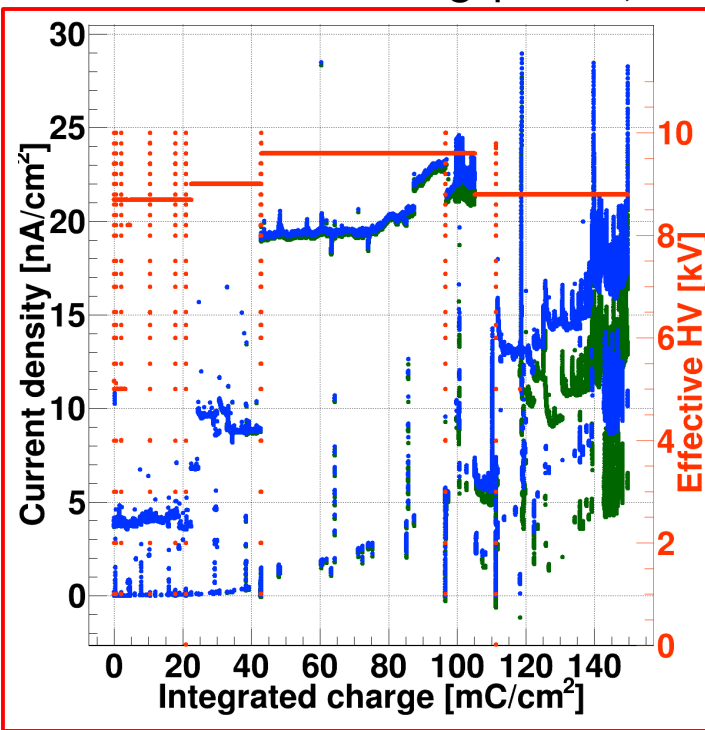

- Effective high voltage of SHiP RPC moved in steps up to 9.8 kV
→ Only RPC of the collaboration to reach full efficiency
- For lower HVs
→ Current trend stable over time
- When HV increased
→ Current increase + appearance of instabilities (under investigation)

- Similar trend for dark current
HV: 8.8 kV
HV: 9 kV
HV: 9.8 kV
- Behavior under investigation

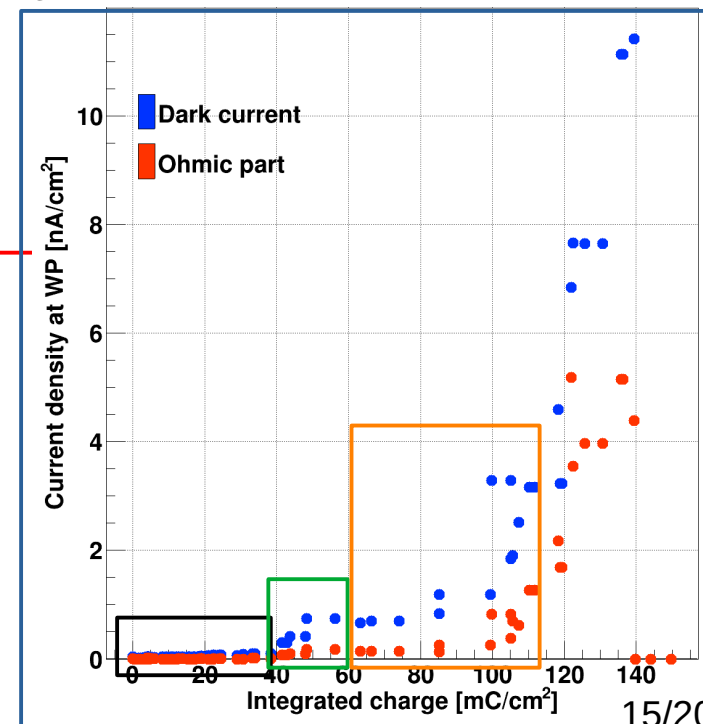

Integrated charge progression

- Status of charge integration for all the RPC ECOgas@GIF++ detectors

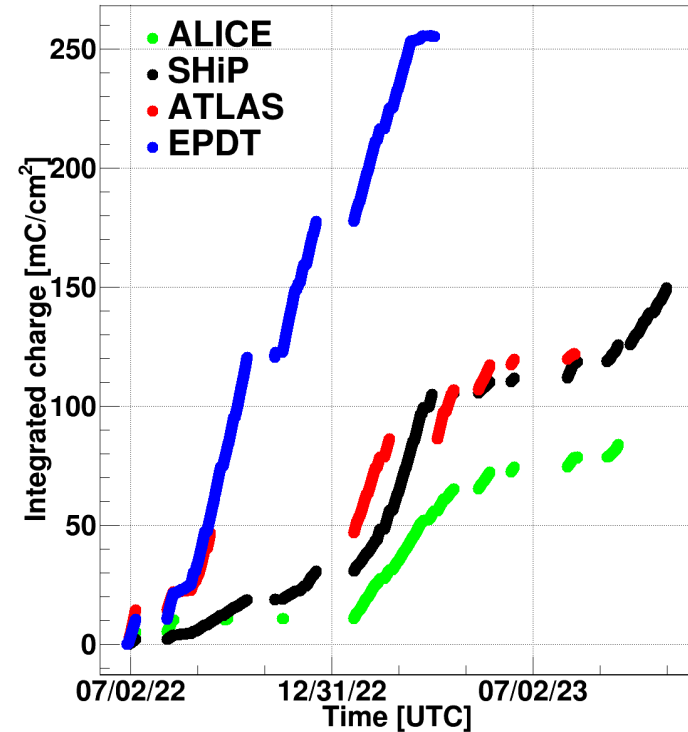
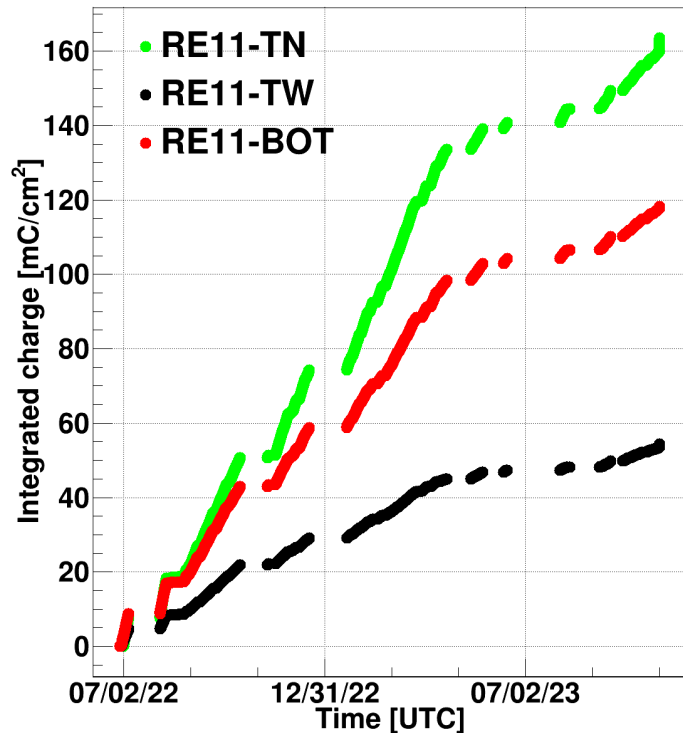

- Different maximum values of integrated charge reached by the different RPCs
 - One year of irradiation
 - ~ 100 mC/cm² on average
 - Irradiation voltage is not the same on all detectors + different distances from the Cs source

RPC performance comparison

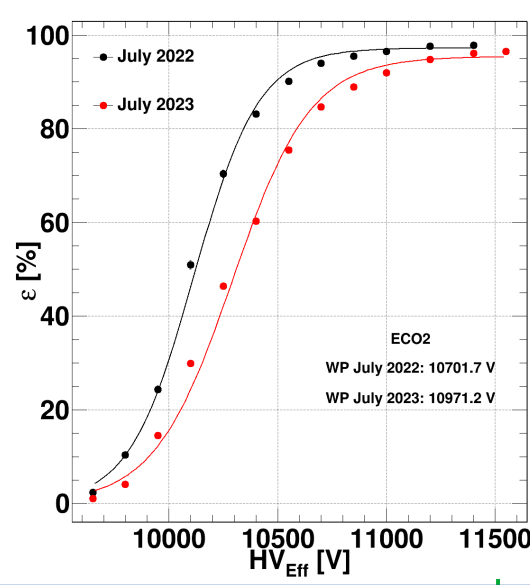
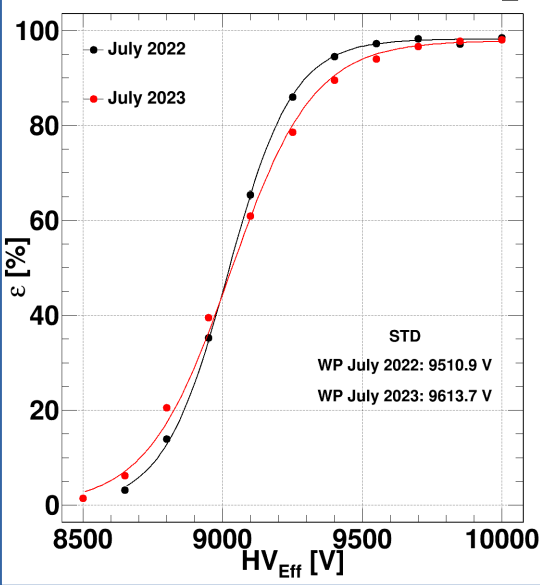

- RPC response to the muon beam
- Efficiency vs HV for STD and ECO2
- 1 year irradiation ($\sim \text{mC/cm}^2$)
- No decrease in maximum efficiency
- Shift of working point in both mixtures

- Could be explained by increase in absorbed current
 - Leading to a voltage drop on the bakelite electrodes
 - Effectively reducing the high voltage applied to the gas
 - Under investigation

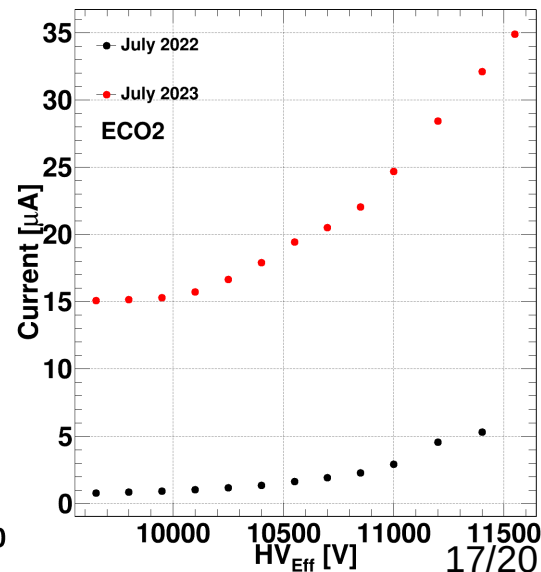
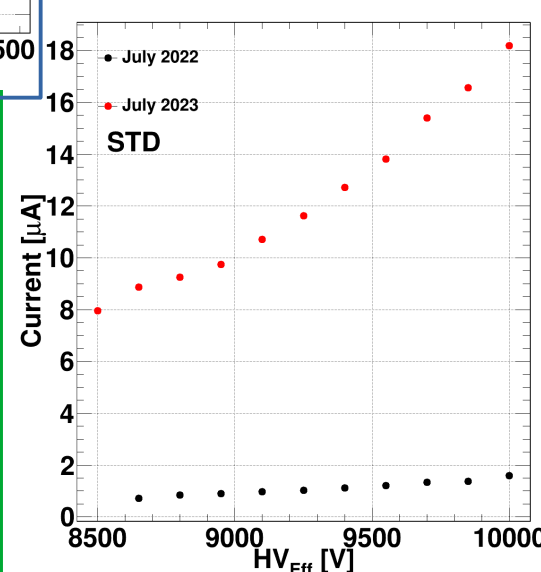

Conclusions

- The RPC ECOgas@GIF++ is carrying out a long-term irradiation test of RPCs with different layouts using HFO/CO₂-based gas mixtures
- Two mixtures have been tested so far
 - ECO1 (50/45 HFO/CO₂), discarded due to unstable currents observed in all the detectors
 - ECO2 (60/35 HFO/CO₂), in-depth study during beam tests, currents more stable over time
- Stability of the current absorbed with ECO2 carried out for all detectors
 - No general unstable trend
 - For some RPCs (e.g. CMS), current is more stable over time. This point is under investigation
- Preliminary analysis of 2022 vs 2023 beam tests performance has started
 - No appreciable decrease in maximum efficiency
 - Shift of working point (ALICE/CMS RPCs) compatible with current increase

Outlook

- Plan to continue irradiation campaign throughout 2024 to accumulate more charge
- Beam tests in 2024 to further compare RPC performance throughout aging studies
- Improvements to the experimental setup to have more parameters under control to better understand the origin of the fluctuating currents observed
 - Measure of potential leakage currents
 - Provide a reading of the gas mixture humidity for each detector
 - Perform systematic ISE measurements (to monitor fluoride impurities production)
- Two papers have been submitted for publication:
 - 1) *High-rate tests on Resistive Plate Chambers filled with eco-friendly gas mixtures* submitted to EPJ-C (on 2021 beam test results)
 - 2) *Preliminary results on the long term operation of RPCs with eco-friendly gas mixtures under irradiation at the CERN Gamma Irradiation Facility*, submitted to EPJ plus focus point on the green transition of particle detectors

References

- [1] Council of European Union, *Regulation (EU) No 517/2014 of the European Parliament and of the Council of 16 April 2014 on fluorinated greenhouse gases and repealing Regulation (EC) No 842/2006* Text with EEA relevance (2014) <https://eur-lex.europa.eu/legal-content/EN/TXT/?uri=CELEX%3A32014R0517>
- [2] A. Bianchi et al., *Characterization of tetrafluoropropene-based gas mixtures for the Resistive Plate Chambers of the ALICE muon spectrometer*, 2019, JINST 14 P11014, <https://doi.org/10.1088/1748-0221/14/11/P11014>
- [3] B. Liberti et al., *Further gas mixtures with low environment impact*, 2016, JINST 11 C09012, <https://doi.org/10.1088/1748-0221/11/09/C09012>
- [4] R. Guida et al., *Performance studies of RPC detectors with new environmentally friendly gas mixtures in presence of LHC-like radiation background*, Nuclear Inst. and Methods in Physics Research, A 958 (2020) 162073, <https://doi.org/10.1016/j.nima.2019.04.027>
- [5] R. Albanese et al., *RPC-based Muon Identification System for the neutrino detector of the SHiP experiment*, 2023, JINST 18 P02022, <https://doi.org/10.1088/1748-0221/18/02/P02022>
- [6] Abbrescia, M., et al.: *Operation, performance and upgrade of the CMS Resistive Plate Chamber system at LHC*. Nuclear Instruments and Methods in Physics Research Section A: Accelerators, Spectrometers, Detectors and Associated Equipment 732, 195–198 (2013) <https://doi.org/10.1016/j.nima.2013.05.150605>
- [7]
- [8]

**Thank you for your
attention!**

Backup

To be added in backup

- 1) Screenshot of grafana monitoring page
- 2) Maybe results of ISE measurements
- 3) Photo of the RPC setup itself
- 4) More TB results?

Experimental setup – beam tests

- Two main beam test objectives:

- 1) Collect muon signals, for RPC performance studies
- 2) Measure the gamma rate on the detector for rate capability studies

- 1) Trigger provided by coincidence of 4 scintillators
→ $10 \times 10 \text{ cm}^2$ trigger area

- 2) Random trigger to periodically sample RPC response

- Two readout methods employed:

- 1) Front-end electronics + TDCs
→ Realistic measurements of efficiency and cluster size

- 2) CAEN digitizer (for some RPCs)
→ Waveform/charge studies

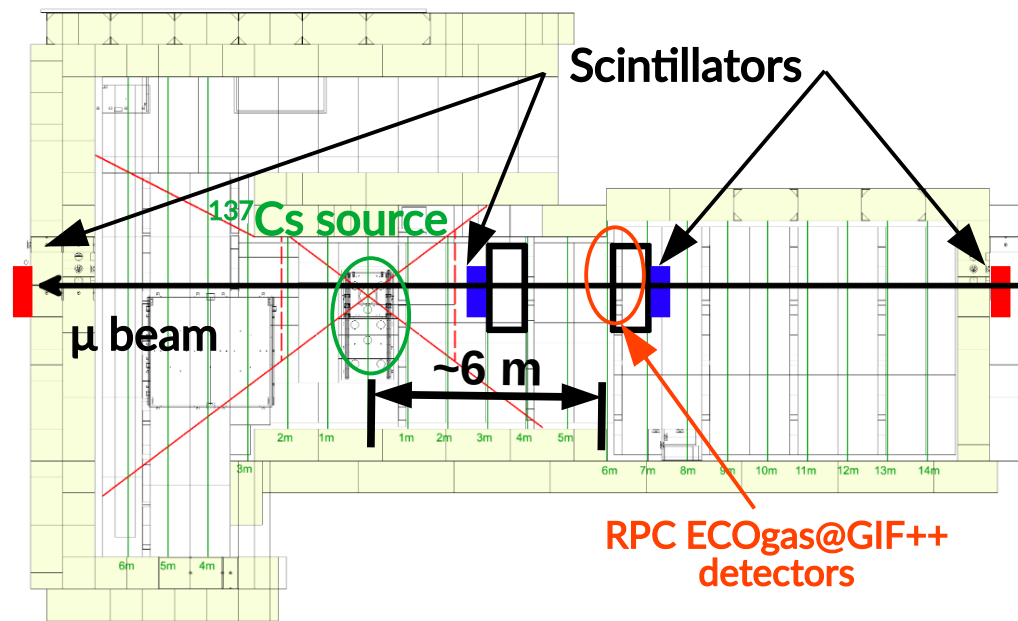

Sketch of the beam test setup @ GIF++

- TDC: CAEN V1190, 128 ch, 100 ps time resolution
- Digitizer: various models with sampling of 2.5 and 5 Gs/s and 12/14 bit resolution