

Report on Demonstrator construction: magnet construction

PTOLEMY GM in Princeton, 6-8 of November, 2023

MM on behalf of the Princeton and LNGS group

The PTOLEMY area



Experimental area under transformation

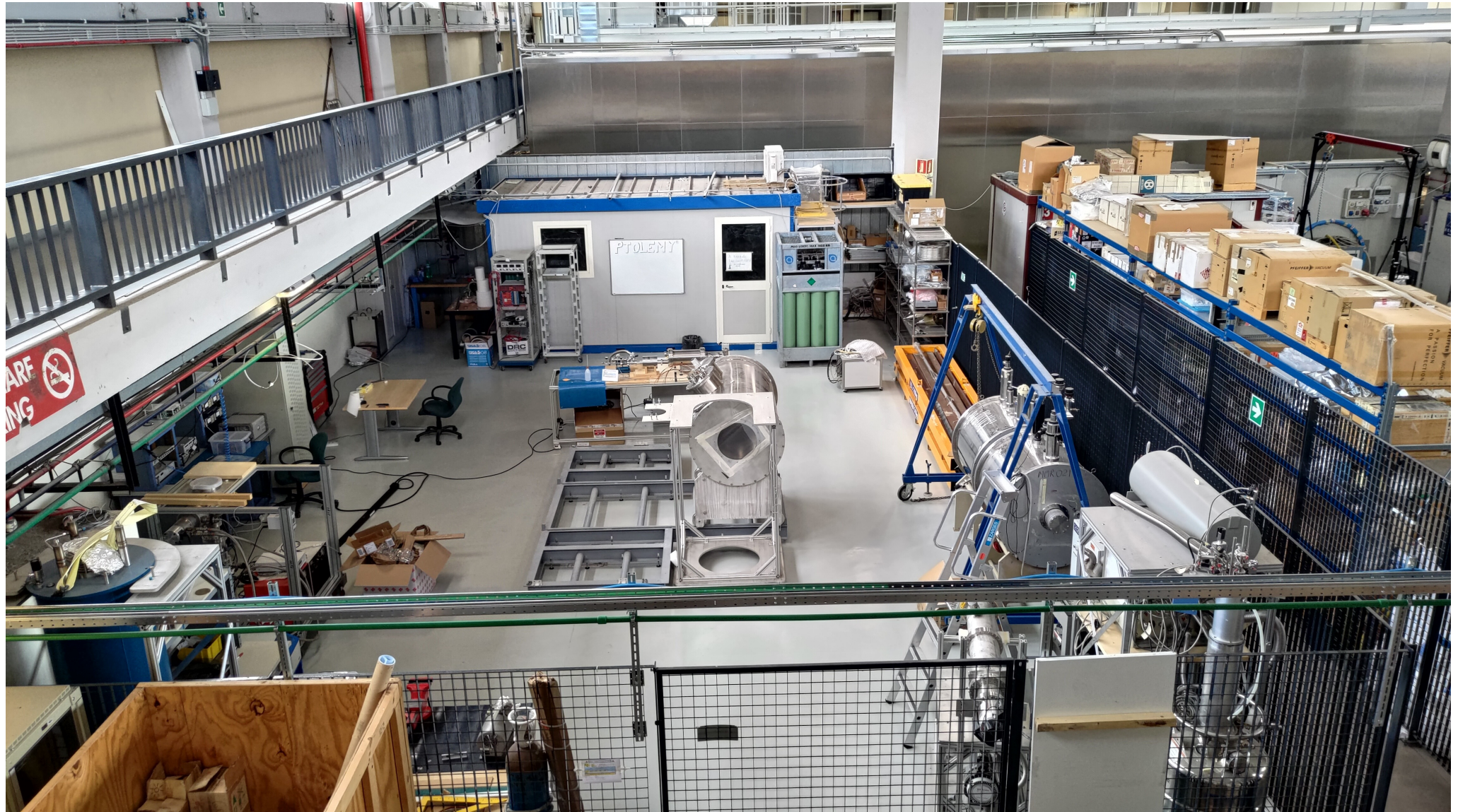

Ref. ASG/23.080 /AP

Attn. to: Dr. Christopher Tully

Email: cgtully@princeton.edu

Date: October 30th, 2023

Subject: Design and supply of PTOLEMY LNGS SC Magnet, based in an MgB₂ Solution.
ASG Offer 23013 Rev.00

Dear Chris,

Following our discussions please find here below our quotation for the design, manufacturing and testing of a MgB₂ magnet solution for PTOLEMY LNGS SC Magnet (this latter referred to as the “**PTOLEMY LNGS Magnet**”) for the University of Princeton (herein after the “**Customer**”) as better described in the following.

1) Introduction

The PTOLEMY LNGS Magnet is designed to be a C-type dipole with extension arms to one side of the pole faces for shaping the fringe field (the “**Horns**”) and achieve a constant and uniform 1 T field in the airgap. The resistive version is shown in the Figure 1. The purpose of this offer is to provide cryogen-free superconducting coils to optimize performance and energy efficiency.

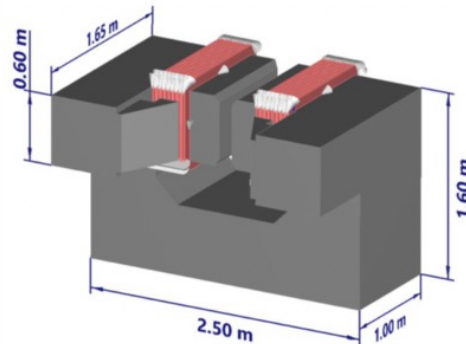

2) Scope of Supply

The scope of work consists in the design, manufacturing and supply of a MgB₂ superconducting Magnet and delivery to CERN, Geneva, Switzerland (CH) (the “**Scope of Supply**” or the “**Supply**”).

The Scope of Supply covers the following parts and activities:

- Detail design of the MgB₂ coils, cryostats and iron yoke.
- Manufacturing design (drawings and design verifications where request by Customer) of each component.
- Construction and assembling design of all the components and assembled magnet.
- For the sake of clarity:
 - (i) ASG shall supply the PTOLEMY LNGS Magnet yoke without Horns
 - (ii) ASG shall use the draft design of the Horns provided by the Customer by the date of this offer in order to design the yoke and to verify that Horns have no impact on coils and mechanical stability.
 - (iii) the magnetic field in the air gap region as set forth in the items n. 4 for the acceptance at the FAT will be measured without the Horns
 - (iv) the Customer shall be free to modify the Horns design after acceptance of the PTOLEMY LNGS Magnet without ASG being in any way responsible of the possible modification of the magnetic field intensive and homogeneity.
- Procurement of the iron yoke.
- Tests according to QCP (Quality Control Plan).
- Assembly of the whole system, including the ancillary equipment, at ASG’s factory in Genoa.
- Acceptance Test at ASG’s factory in Genoa. This shall constitute the final acceptance event for the Customer.
- Redaction of the final documentation of the coil system.
- The parties shall agree immediately after contract signature about the content of a quality control plan (QCP) to be provided by ASG.
- The transport and the delivery of the Supply will be at the European Organization for Nuclear Research (CERN), in Meyrin (Cantone of Geneve), Switzerland (CH) according to CIP (Incoterms 2020). Upon arrival to CERN the Scope of Supply shall enter the ownership of the Customer.

Not included in the supply are:

1. Any and all Civil works at Customer premises and /or CERN site.
2. Power supply: ASG shall specify the power supply and provide guidance to the Customer for the relevant procurement.
3. Vacuum pumps.
4. Water cooling system for the cryocooler helium compressor.
5. The design, manufacture, assembly, and testing of the ferromagnetic extensions referred to as Horn will not be part of the Scope of Supply.

Progress

First mechanic design

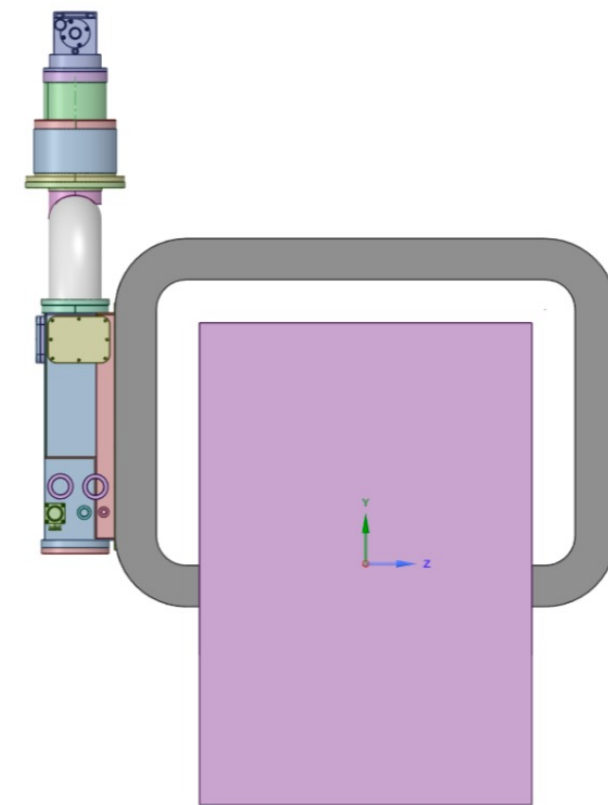
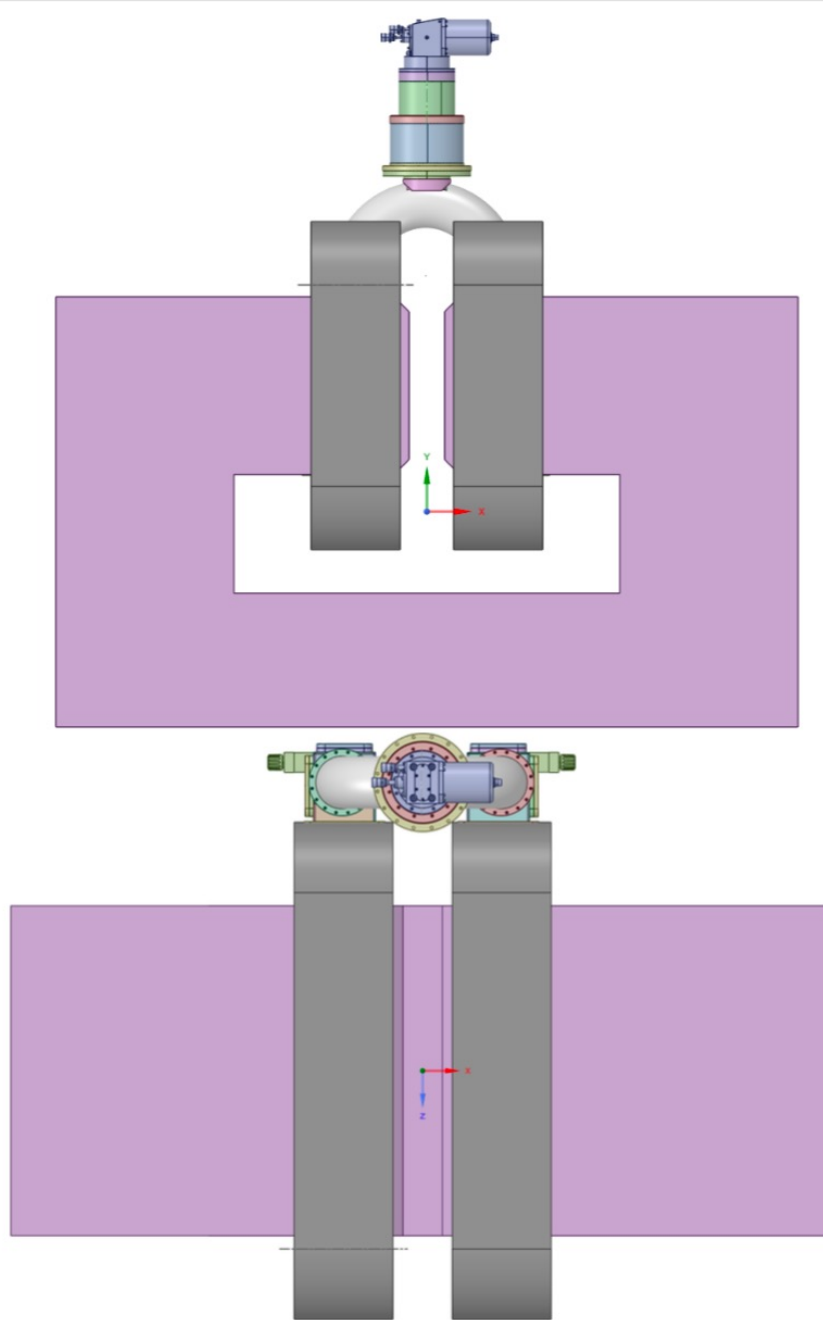
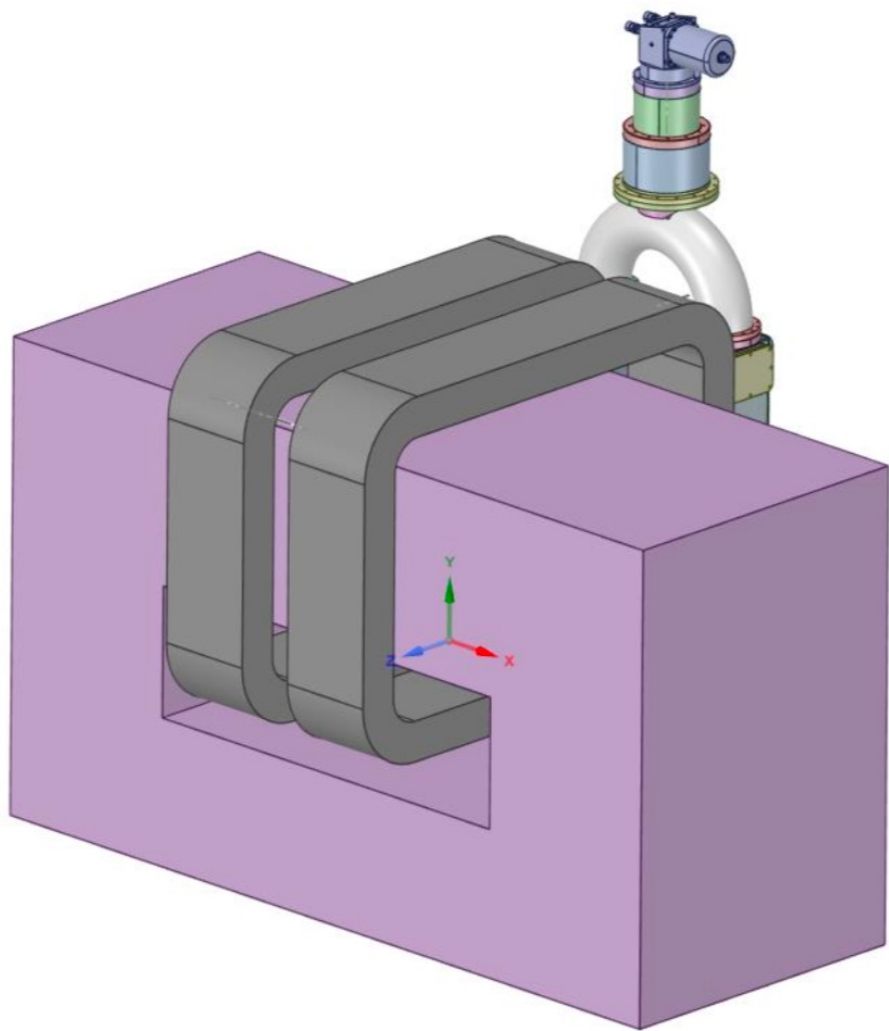

- Chamfer in Z direction (electron propagation direction)
- Cut iron in low field region
- First mechanic design
- The horn is close to the coil, it may affect the superconductor performance

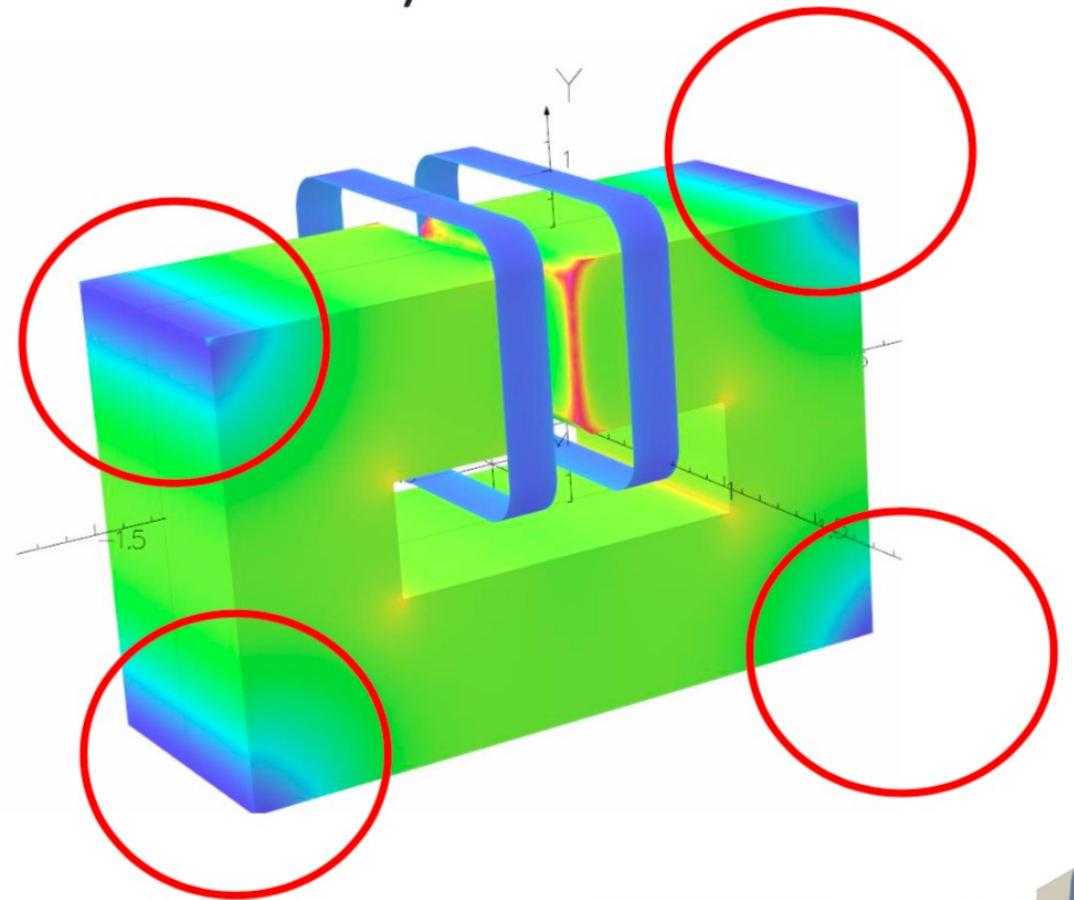
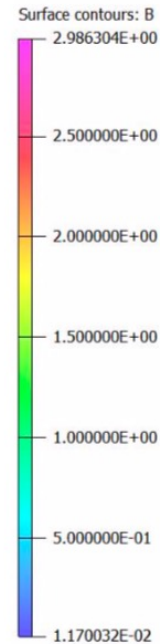

Progress

Chamfer in Z direction (electron propagation direction)

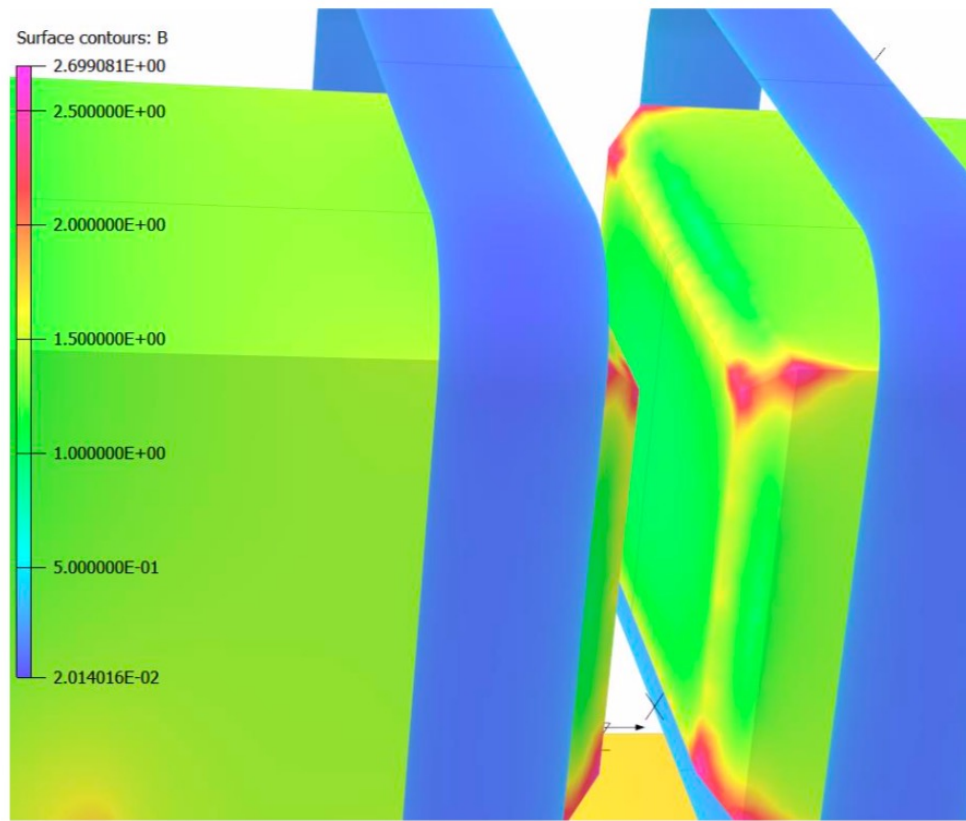

Chamfer Depth (m)	10*10*70 (cm) (%)	8*8*30 (cm) (%)
0	0.098	0.014
0.025	0.105	0.014
0.05	0.137	0.0105
0.1	1.02	0.0081

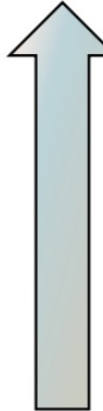

Progress

Cut iron in low field region

Cut Depth (m)	10*10*70 (%)	8*8*30 (%)	Weight (kg)	B
0	0.098	0.014	0	0.97 T
0.01	0.096	0.014	1.6 kg	0.967 T
0.05	0.098	0.014	39.3 kg	0.966 T
0.1	0.098	0.014	157.2 kg	0.966 T
0.15	0.103	0.014	353.7 kg	0.966 T
0.3	0.095	0.014	1414.8 kg	0.964 T
0.4	0.095	0.014	2515.2 kg	0.96 T
0.45	0.103	0.014	3183.3 kg	0.95 T
0.5	0.097	0.013	3930 kg	0.939 T
0.6	0.081	0.012	5659.2 kg	0.89 T
0.7	0.066	0.011	7702.8 kg	0.81 T
0.8	0.063	0.012	10060.8 kg	0.71 T



Progress

Forces in the coil

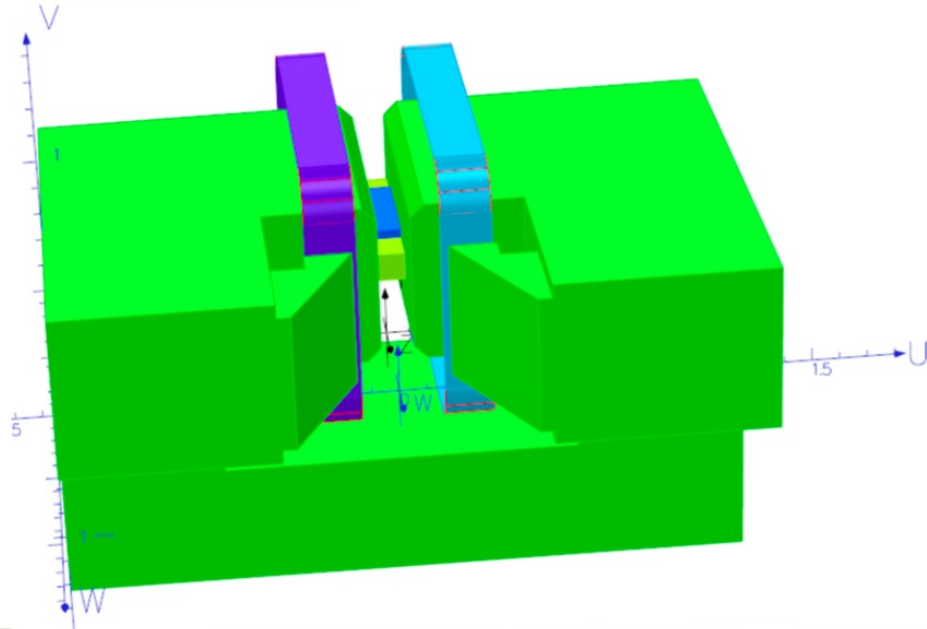
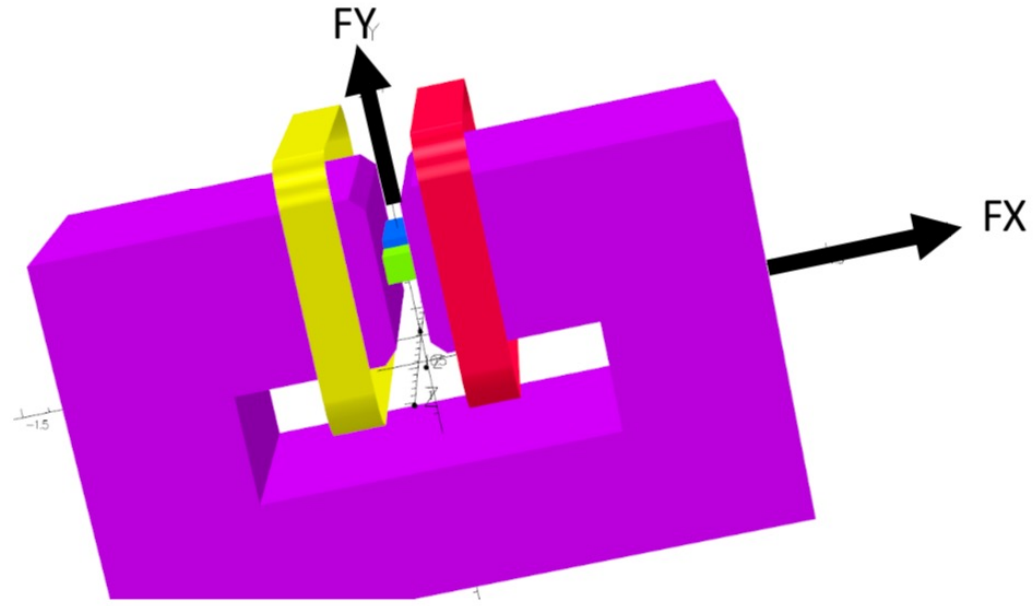

	MAXWELL		OPERA	
	NO HORN	HORN	NO HORN	HORN
FX	10.8 kN	12.5 kN	11.6 kN	13.4 kN
FY	0.042 kN	0.025 kN	0.097 kN	-0.004 kN
FZ	0.001 kN	0.205 kN	0.002 kN	0.296 kN
MX	4 Nm		3 Nm	
MY	12 Nm		944 Nm	
MZ	108 Nm		102 Nm	

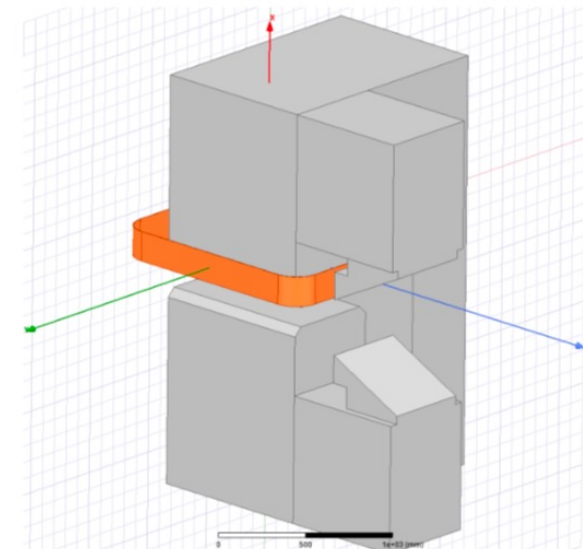

Progress

The horn is close to the coil, it may affect the superconductor performance

Mag_LNGS

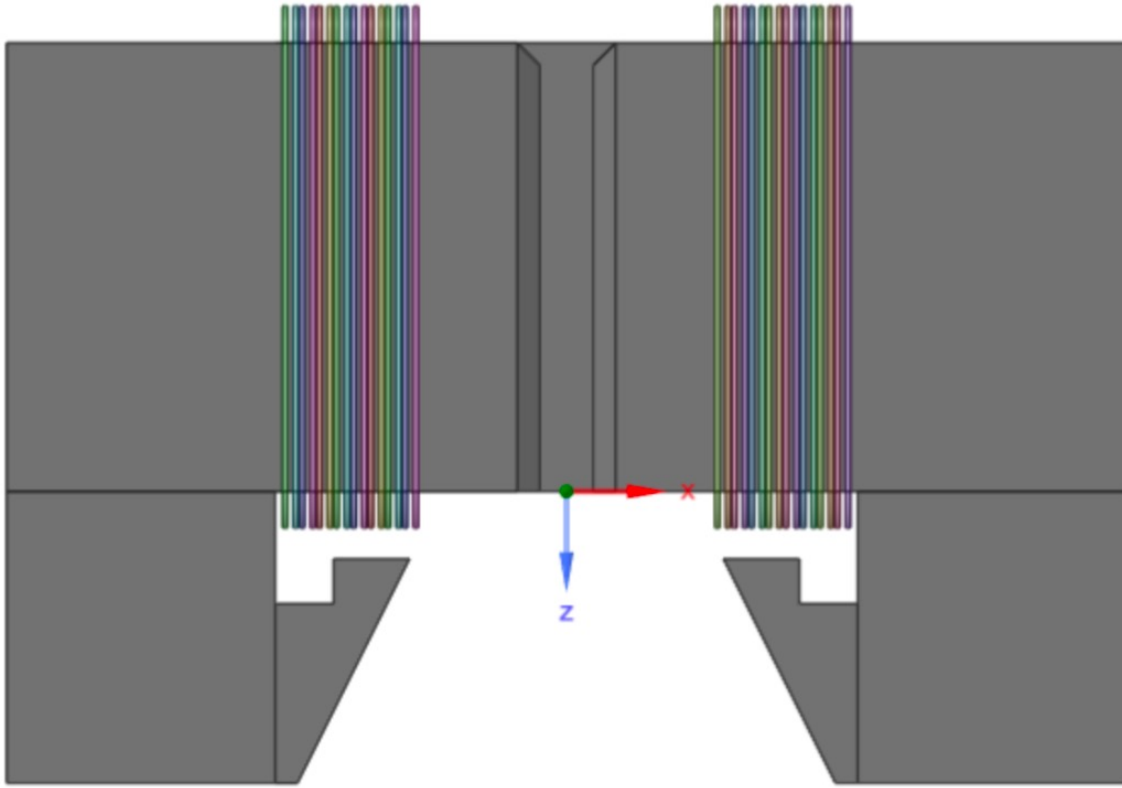

SUPRASYS

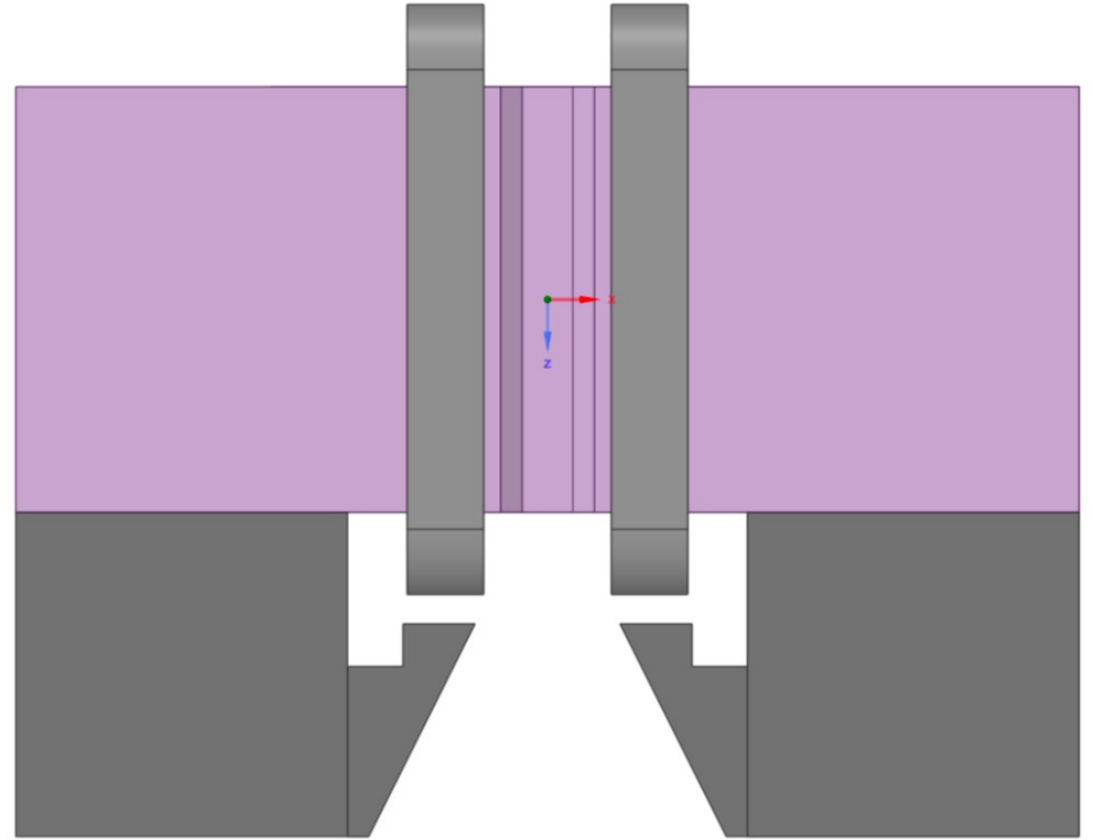

Iron weight

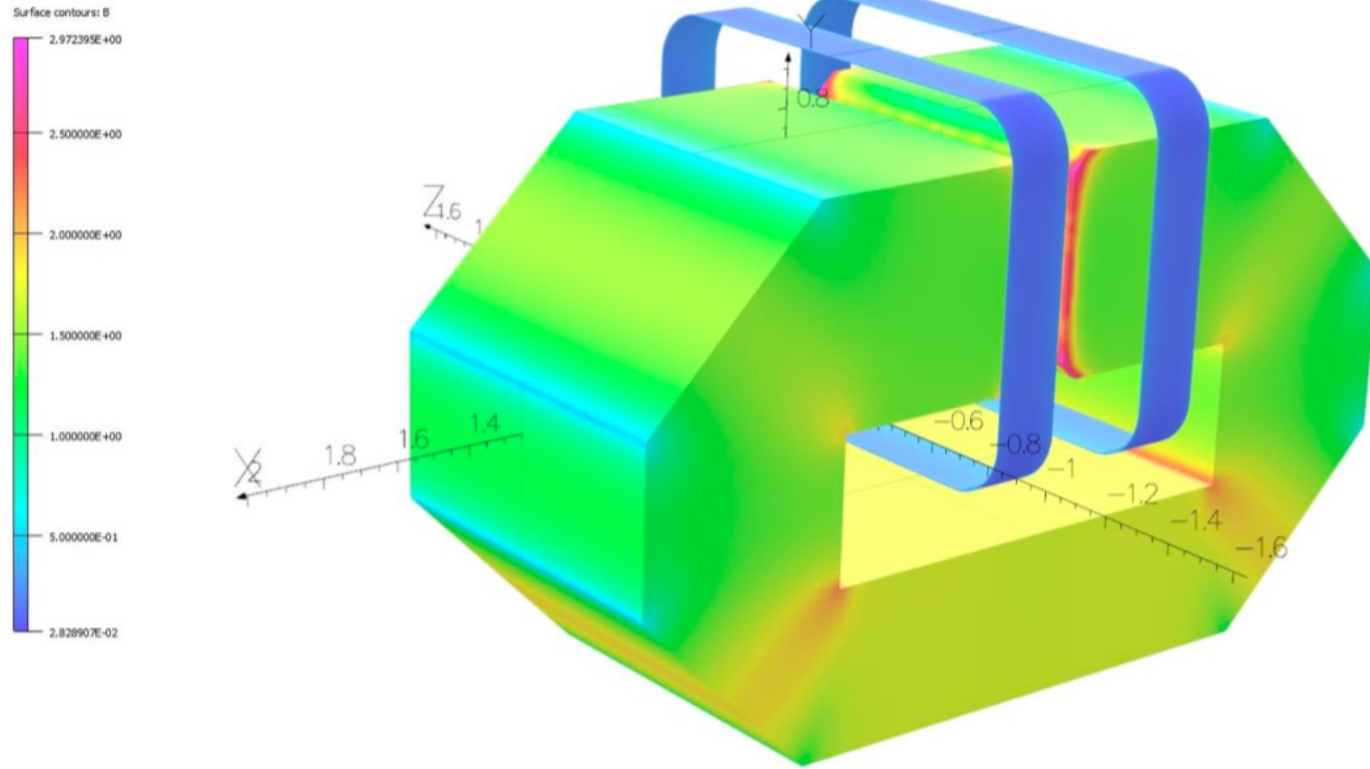

2.53 m³-----19885 kg



The influence of horns in the magnetic field peak

The maximum magnetic field value is: 0.398 T J_c is [3.9e+08 A/m²]

The maximum magnetic field value is: 0.432 T J_c is [3.76e+08 A/m²]

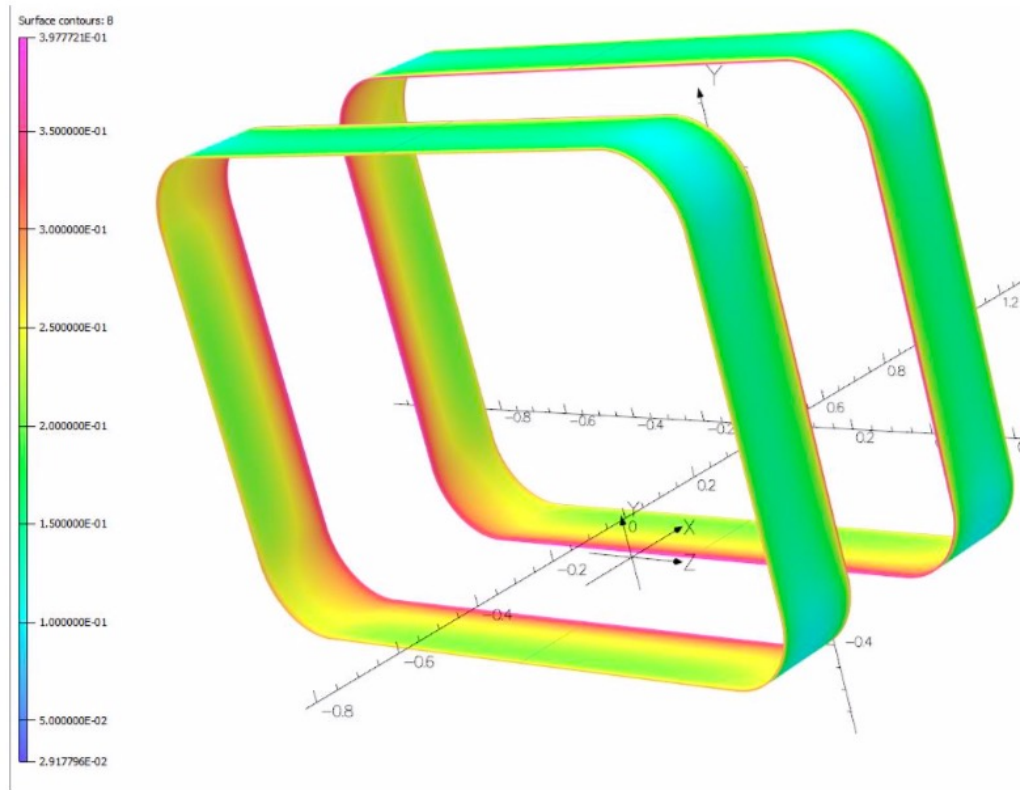

Although the maximum field in the superconductor is increased by 8%, the critical current is reduced by less than 4%.



First thermal balance evaluation

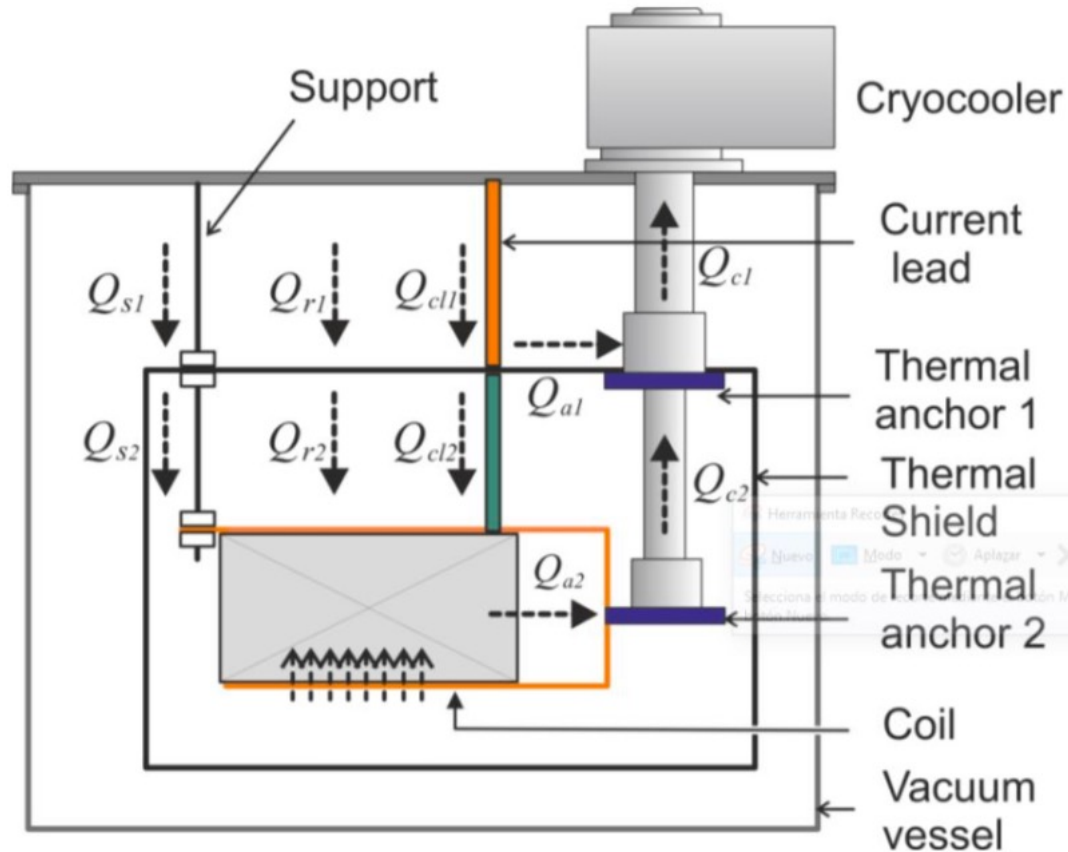

Heat inputs at 20K per coil: 1.35 W

Heat inputs at 80K per coil: 20.2 W

(QR2) Radiation heat input at 20K per coil: 0.65 W

Radiation heat input at 20K per coil at connection: 0.31 W

(QS2) Conduction heat input at 20K per coil: 0.2 W

Conduction heat input at 20K per coil at connection: 0.1 W

(QR1) Radiation heat input at 80K per coil: 5.77 W

Radiation heat input at 80K per coil at connection: 2.73 W

(QS1) Conduction heat input at 80K per coil: 0.561 W

Conduction heat input at 80K per coil at connection: 0.2805 W

(Qcl1) Heat input through current leads at 80K per coil: 10.86 W

(Qcl2) Heat input through current leads at 20K per coil: 0.098 W



	Cryomech	Leybold	Sumitomo
Certified performance	25 W @ 20 K	18 W @ 20 K	5,4 W @ 10 K
	115 W @ 80 K	115 W @ 80 K	30W @ 45 K
Performance at operational conditions	25 W @ 20 K	18 W @ 20 K	20 W @ 20 K
	115 W @ 80 K	115 W @ 80 K	70W @ 80 K

Influence of coils position

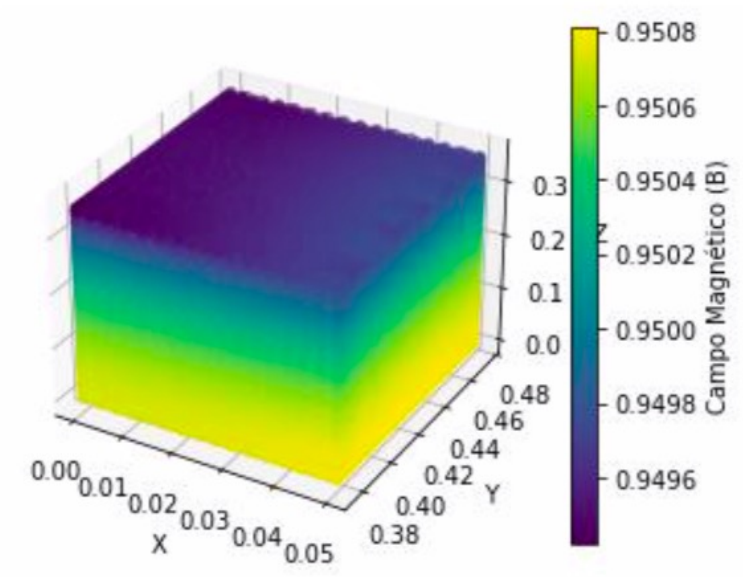
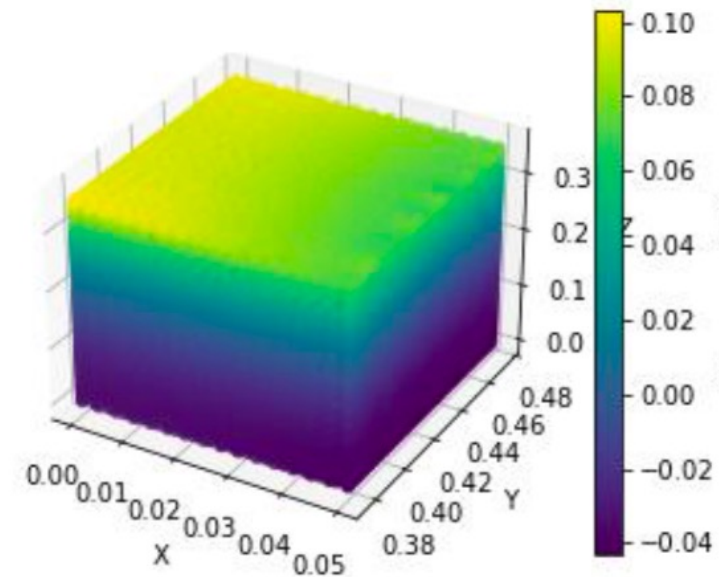
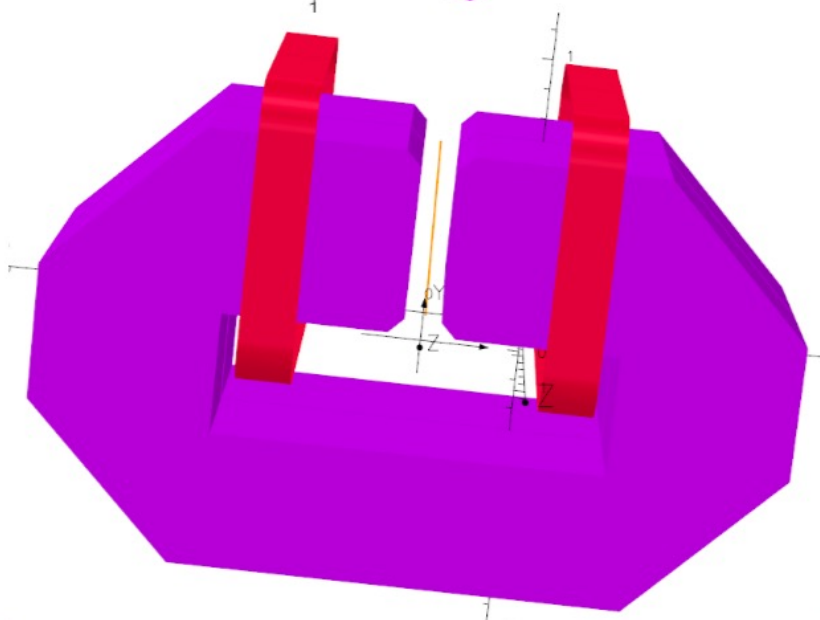
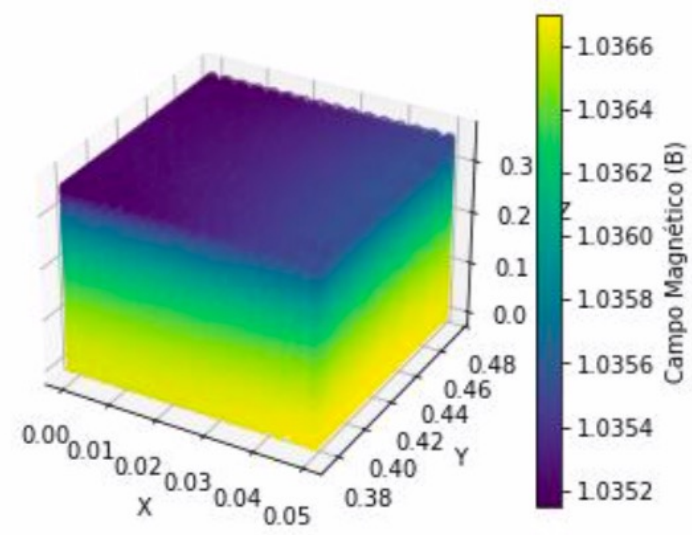
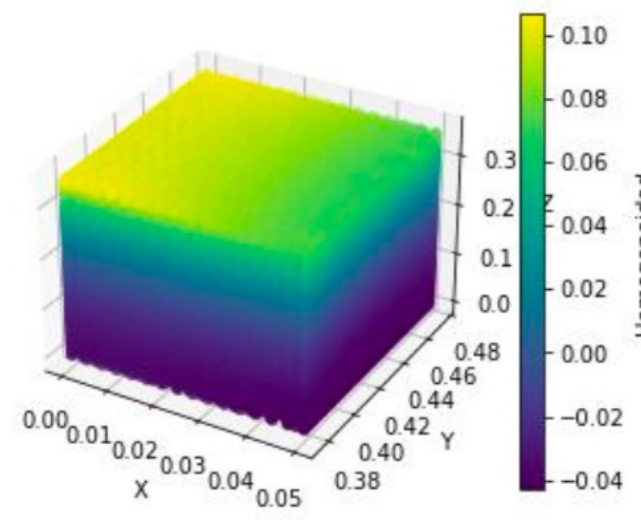
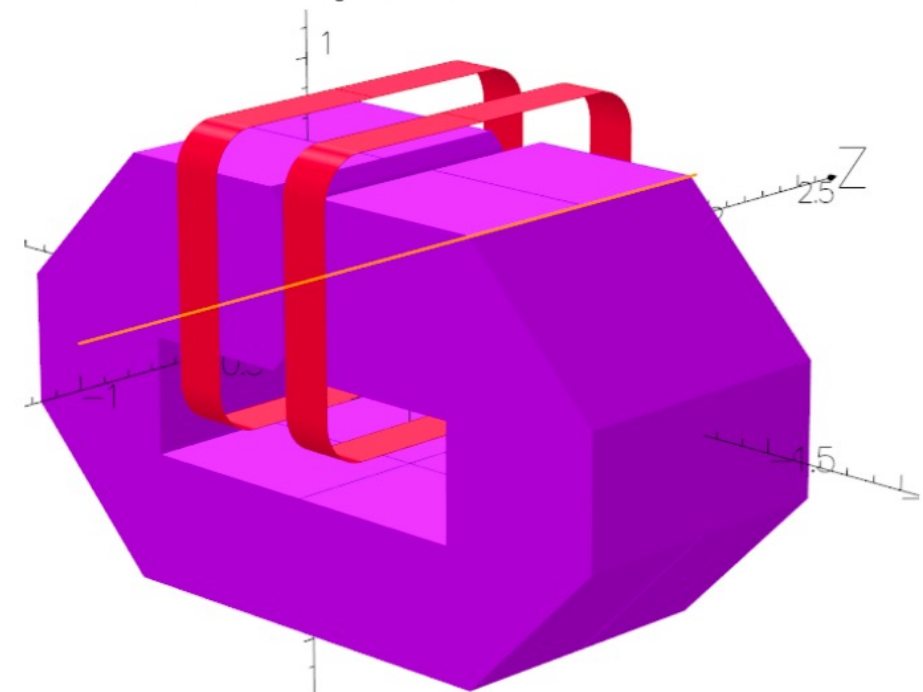

Influence of the position of the coils on the dipole field

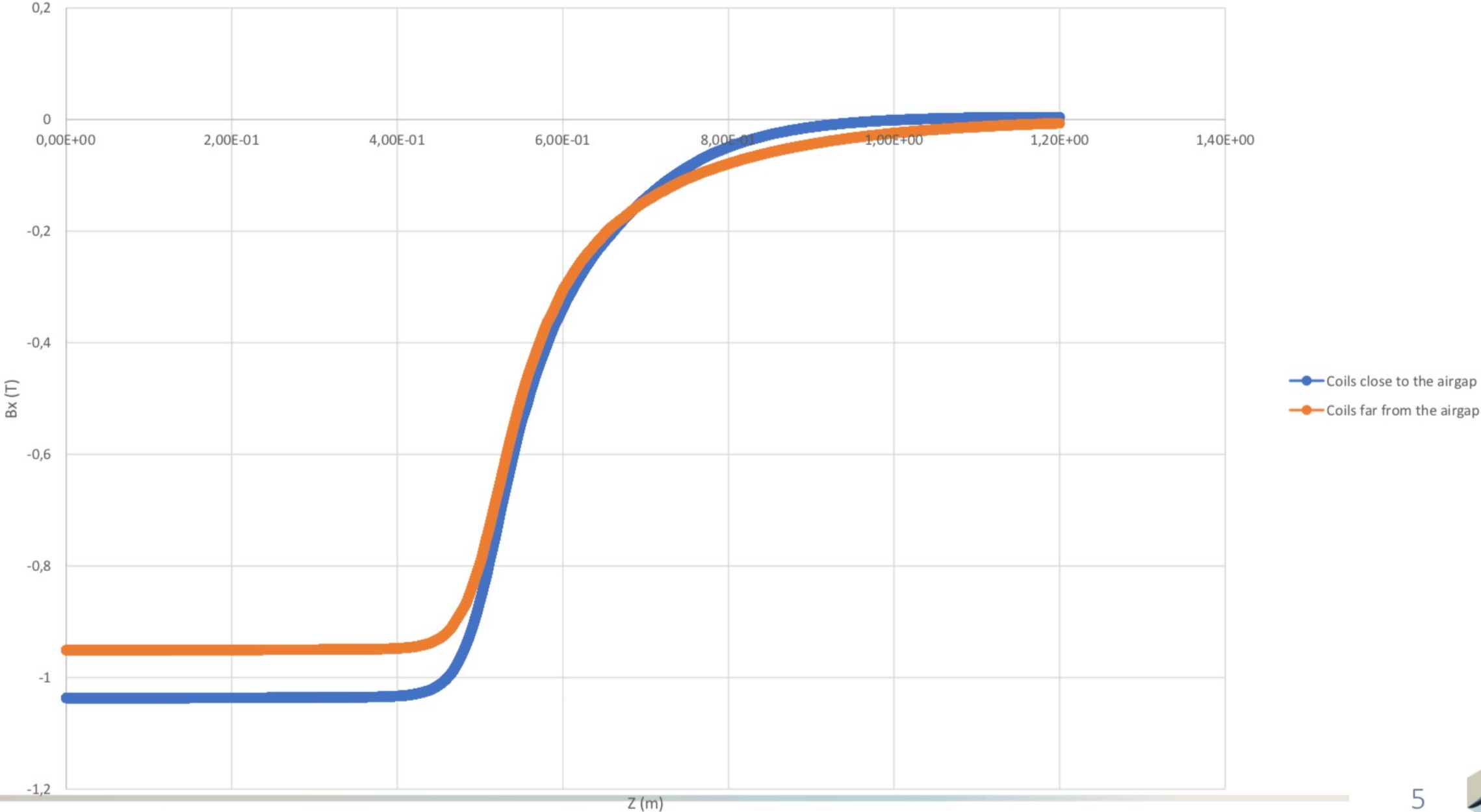

Influence of the position of the coils on the dipole field after the coils

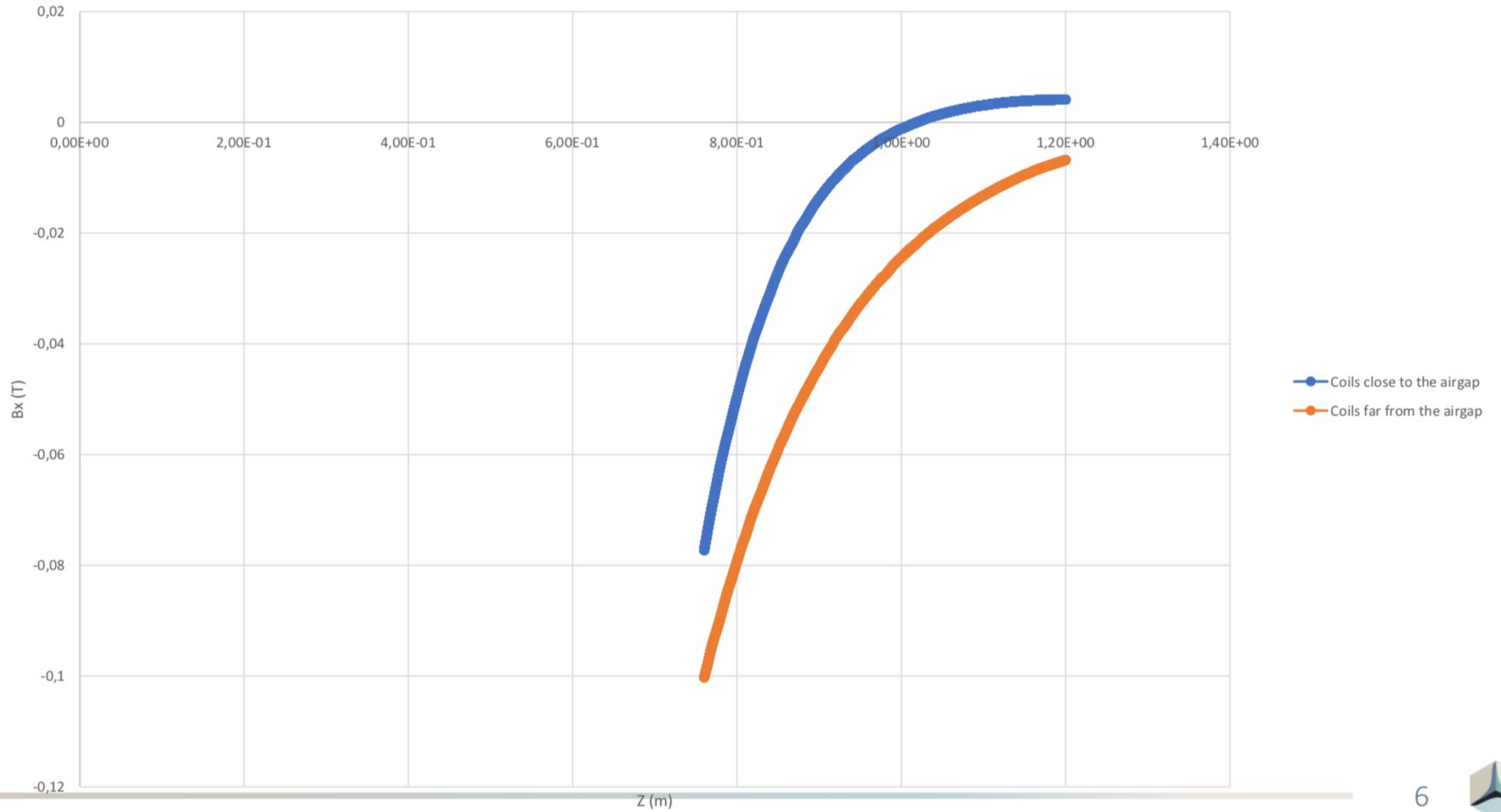

Different configurations of coils

Coils close to the airgap

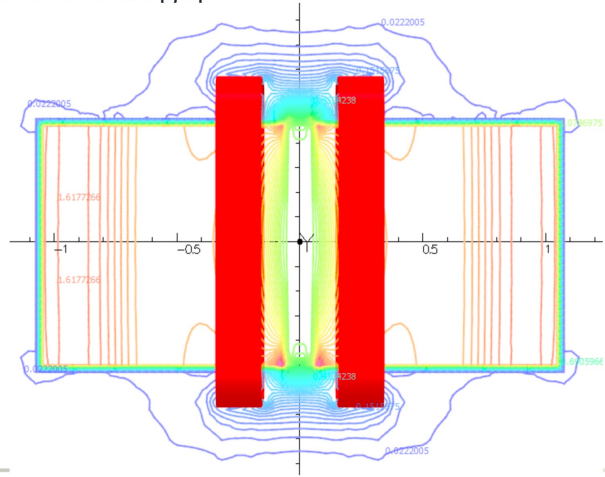

3

Coils close to the airgap with horns

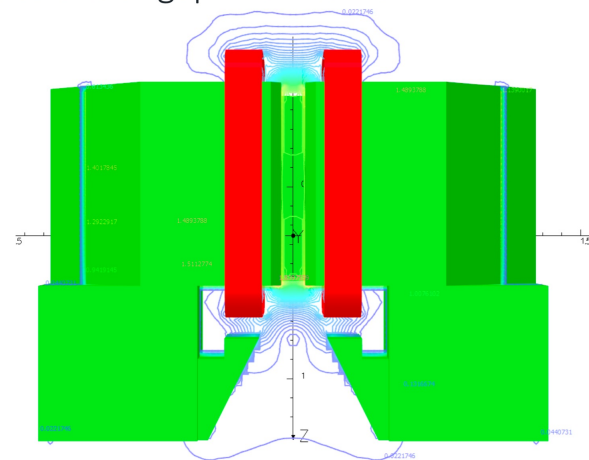

4

Coils far from the airgap

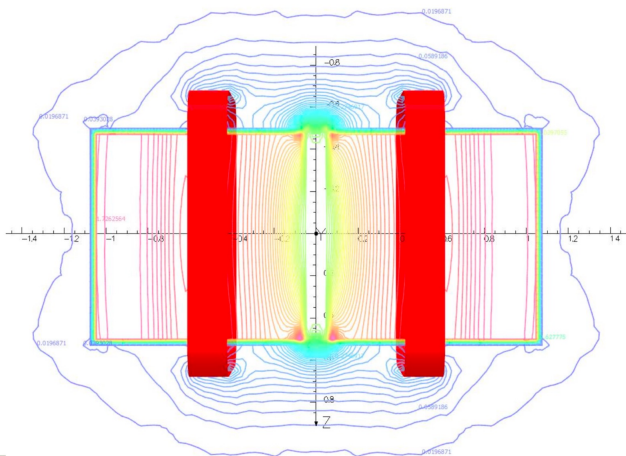

5

Coils far from the airgap and reduced distance to iron

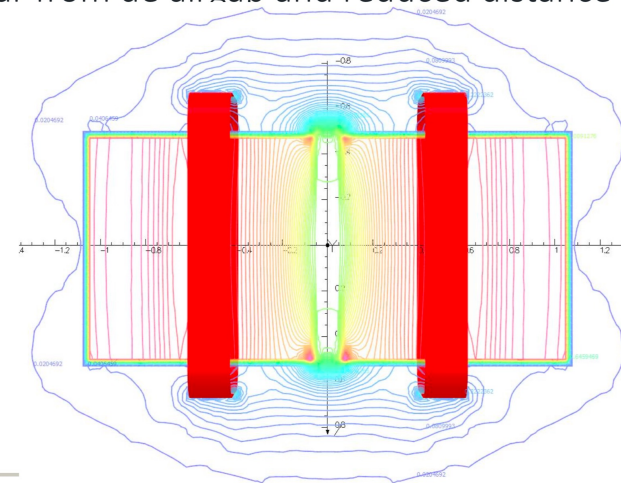

6

Further investigation on magnet desing

Influence of coils position on dipole field

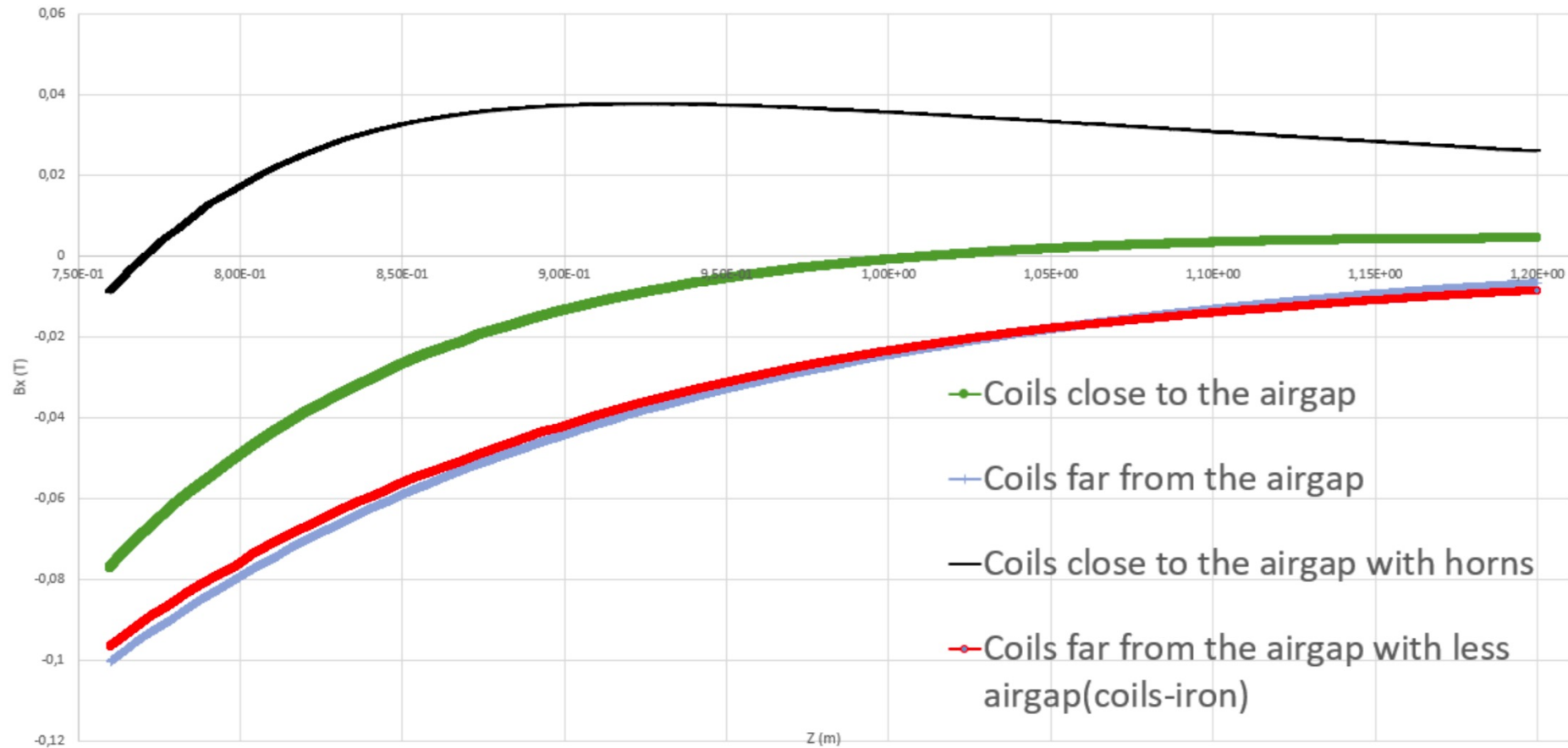

Power supply

Required voltage: 5 V

Current required: 200 A

Power requirement: 1kW

Current stability of 0.01%



Conclusions

- The offer was issued, and PRINCETON University is ready to issue the order.
- We are investing more time than expected cross-checking the design
- We are confident we can save some construction time. The features of the hardware we requires are quite standard.
- I do not make prediction now, hopefully by the end of the year we can have a better understanding of the delivery time.