

# A SQUID controller unit for space-based applications: design and first performance tests

Paolo Dal Bo<sup>a,b,c</sup>, Andrea Limonta<sup>d,e</sup>, Andrea Passerini<sup>d,e</sup>, Andrea Moggi<sup>a</sup>, Andrea Tartari<sup>a</sup>, Eugenia Di Giorgi<sup>a,b,c</sup>, Gabriele Coppi<sup>d</sup>, Giovanni Signorelli<sup>a,b</sup>, Giulia Conenna<sup>d,e</sup>, Graeme Smecher<sup>f</sup>, Jean-Francois Cliche<sup>g</sup>, Joshua Montgomery<sup>g</sup>, Kateryna Lenova<sup>a</sup>, Mario De Lucia<sup>a,b</sup>, Mario Zannoni<sup>d,e</sup>, Matt Dobbs<sup>g</sup>, Maurizio Massa<sup>a</sup>, Michele Pinchera<sup>a</sup>, Stefano Della Torre<sup>e</sup>, Tommaso Lari<sup>a,b</sup>.

<sup>a</sup>INFN Sezione di Pisa and <sup>b</sup>Dipartimento di Fisica, Università di Pisa, Largo B. Pontecorvo 3, 56127 Pisa, Italy

<sup>c</sup>Università di Trento, Via Calepina 14, 38122 Trento, Italy



<sup>d</sup>Dipartimento di Fisica, Università di Milano Bicocca, <sup>e</sup>INFN Sezione di Milano Bicocca, Piazza della Scienza 3, 20126 Milano, Italy

<sup>f</sup>Three-Speed Logic, Inc. Victoria, B.C., Canada

<sup>g</sup>Department of Physics and McGill Space Institute, McGill University, 3600 Rue University, Montreal, Canada



## THE READOUT ELECTRONICS OF LITEBIRD EXPERIMENT: PHYSICS MOTIVATION AND OVERALL DESCRIPTION

The CMB polarization anisotropies provide important information about the early moments of the universe. In particular, measuring odd-parity polarization patterns (so-called B-modes) would be a clear signal that an inflationary epoch has occurred. Polarization anisotropies are very weak compared to temperature anisotropies: even-parity patterns are on the order of 3  $\mu\text{K}$ , while B-modes could be on the order of 10 nK. The goal of the LiteBIRD mission, which is set to launch in 2032, is to improve the current limit on the tensor-to-scalar ratio,  $r$ , of the perturbations produced by inflation and the source of B-modes, from the current  $3.2 \times 10^{-2}$ . It aims to achieve  $\delta r < 1 \times 10^{-3}$  for a fiducial model with  $r = 0$  [1]. LiteBIRD will deploy about 4,000 transition-edge sensor (TES) detectors in its focal planes. These will be multiplexed into groups of 60 read out through a single SQUID amplifier each, (Superconducting Quantum Interference Device) to limit the power load to the cryogenic stages.

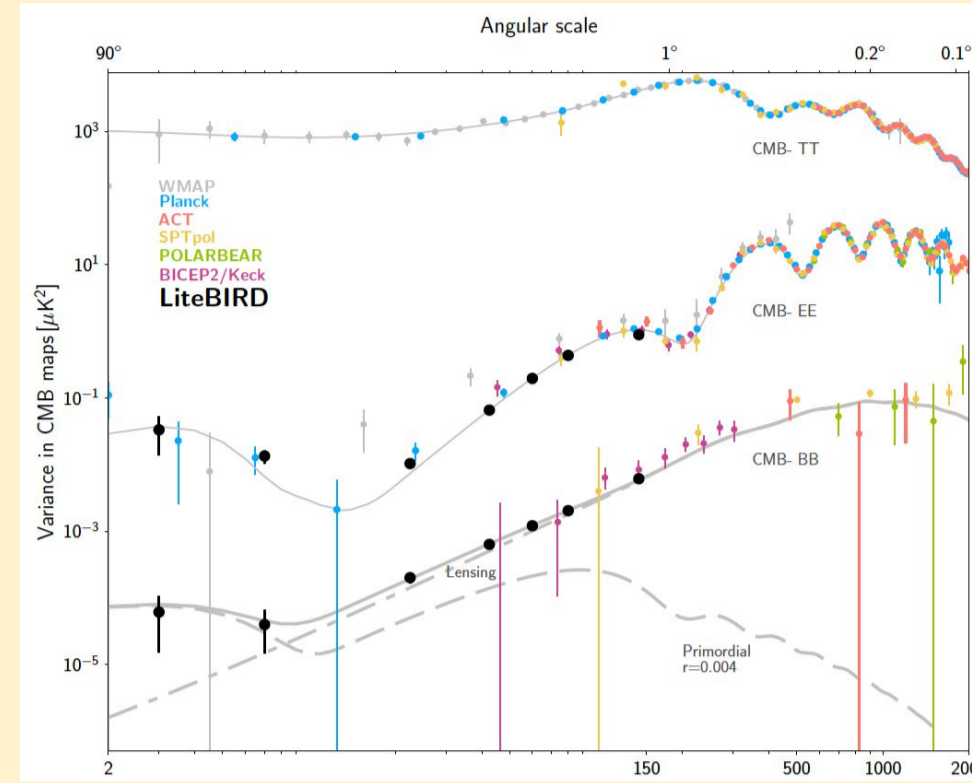

CMB anisotropy angular power spectra: observed and predicted signals for TT, EE, and BB. The low- $l$  BB spectrum is particularly sensitive to inflation.

We have developed a SQUID controller unit for reading out TES sensors, intended for use in a space mission. Each unit can house a maximum of 8 SQUID control assembly (SCA) boards. Each of them is capable of bias and preamplify 4 SQUIDs. The design of these boards is based on those used in ground-based experiments but implements specific modifications to replace COTS components with their space-grade equivalents. Additionally, the thermal interface with the crate has been studied to stabilize the boards temperature in the space environment. There will be one of these units for each of the telescopes on the payload.



The SQUID Control Assembly (SCA) board, each of these controls 4 SQUIDs.

## THE SQUID CONTROLLER UNIT

### ELECTRONICS

The SQUID controller electronics for LiteBIRD is derived from the SPT-3G electronics developed at McGill University. A single board is designed to control four SQUIDs. For LiteBIRD a lightweight communication protocol was implemented, in particular, a custom communication system for bias housekeeping was developed, using discrete components, operating without a system clock, and using only three wires. An ancillary test board based on a Xilinx Artix 7 FPGA was also developed to communicate with the SCA board, route SQUID signals, and interface with benchtop instrumentation. In order to evaluate a possible implementation of cold readout through a dual-stage SQUID system, a new version of the communication protocol, capable of controlling 5 DACs per SQUID instead of 3, is currently under development.

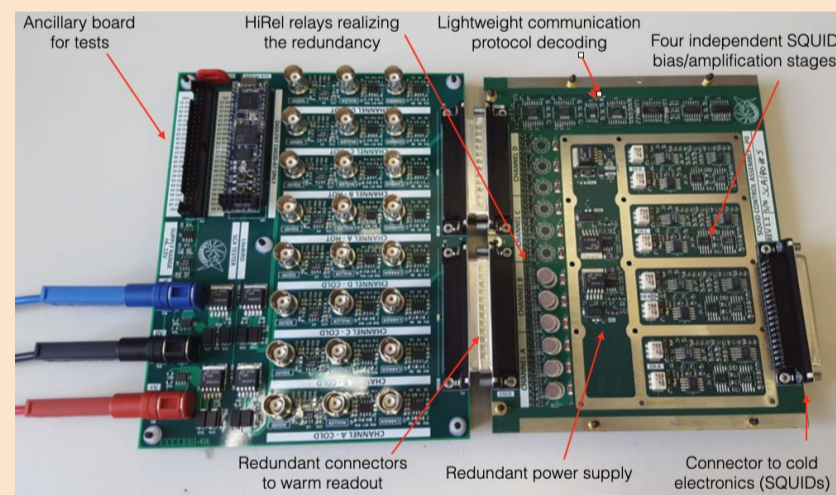

RIGHT: The SCA board (right) connected to the test board (left).

### MECHANICS

The Squid Control Enclosure, SCE, is an aluminum made crate containing the SCA boards held in place by a space grade card-lock system. The mechanical design was based on dimension and weight constraints. The crate fits a 228x209x155 mm<sup>3</sup> volume and the overall weight, including electronic boards, is < 5 kg/unit. The manufacturing process was designed to reduce the number of components and their interfaces in order to simplify EMI shielding. The original design (left crate in the panel on the right) was fabricated and tested. Its design was later modified to simplify the mechanical interface and to provide a larger thermal coupling to the payload, which guarantees a better stability of the temperature of the electronics boards. In addition, in the new design, the board connectors do not extend into the mechanical interface with the payload, which will simplify mounting on the test bench for the vibrational tests that are planned for later this year at the facilities of in Laboratori Nazionali di Frascati together with the thermal vacuum environment tests. A 3D-printed plastic prototype was made to verify the mechanical compatibility with the boards.

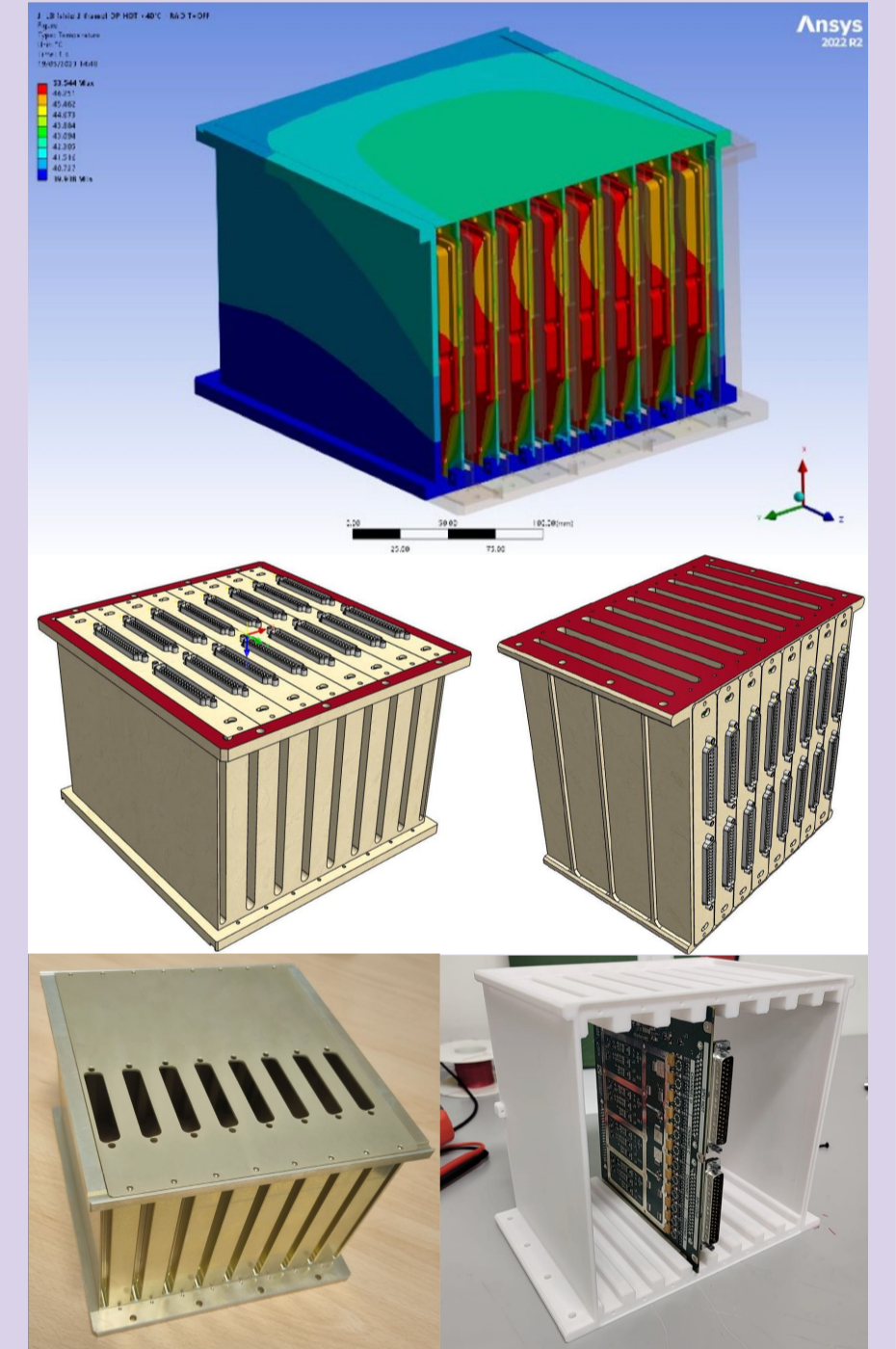

## TESTS

SQUID boards have been tested for electrical and functional performance. The value and linearity of bias and flux control currents are compliant to the expected values, as visible from the figures below. One SCA board, inserted in the SCE prototype, has been used to successfully bias a 48x SQUID series array (StarCryo AR4825) with the cryogenic test facility at INFN Pisa and nominal SQUID parameters as I-V and V-Phi characteristics curves have been measured. Performance tests of the complete SQUID readout + Digital Signal Processing system have been made in McGill cryogenic test facility with representative cold electronics (TESSs, LC filters) to fully characterize noise and bandwidth. These measurements were useful for characterizing the noise introduced by the boards in the readout chain and for decoupling the different noise contributions predicted by the model we developed.

In particular, the noise sources have been divided into voltage noise, whose contribution to the total noise depends solely on the SQUID's transimpedance, and current noise, whose contribution also depends on the dynamic impedance at the bias point. The results of these measurements were consistent with the model's predictions, thereby validating it.

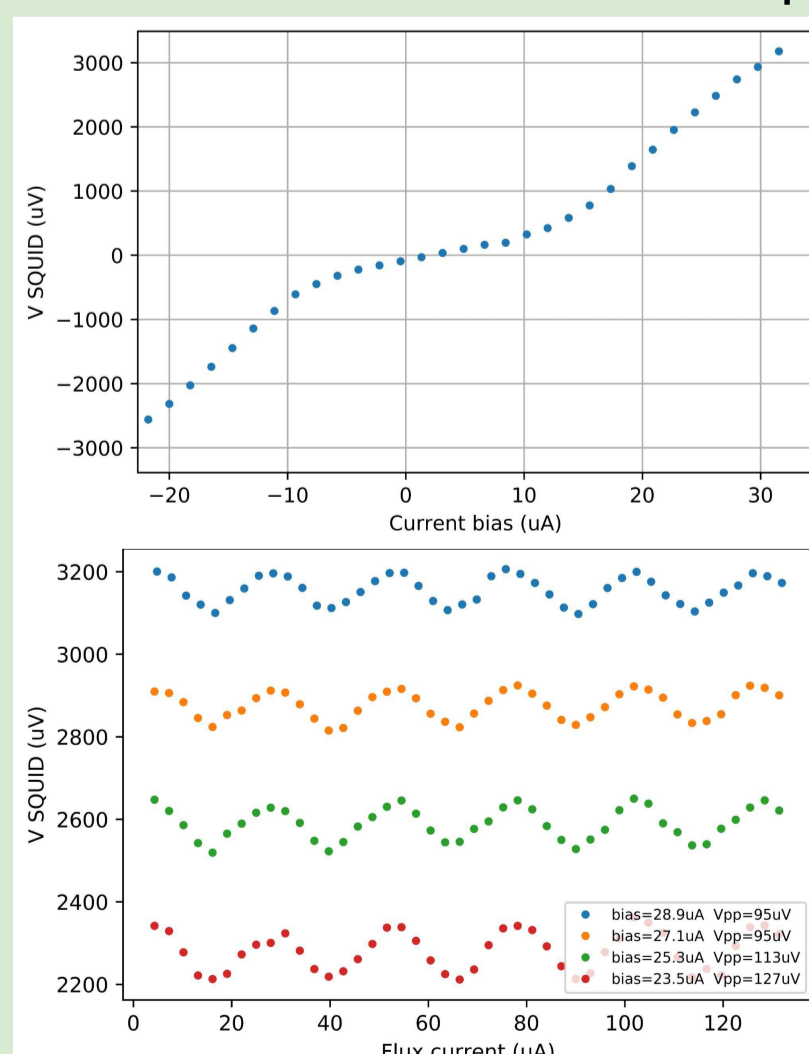

Measured V-I (upper panel) and V-Phi (lower panel) characteristics curves of the SQUID tested in Pisa.

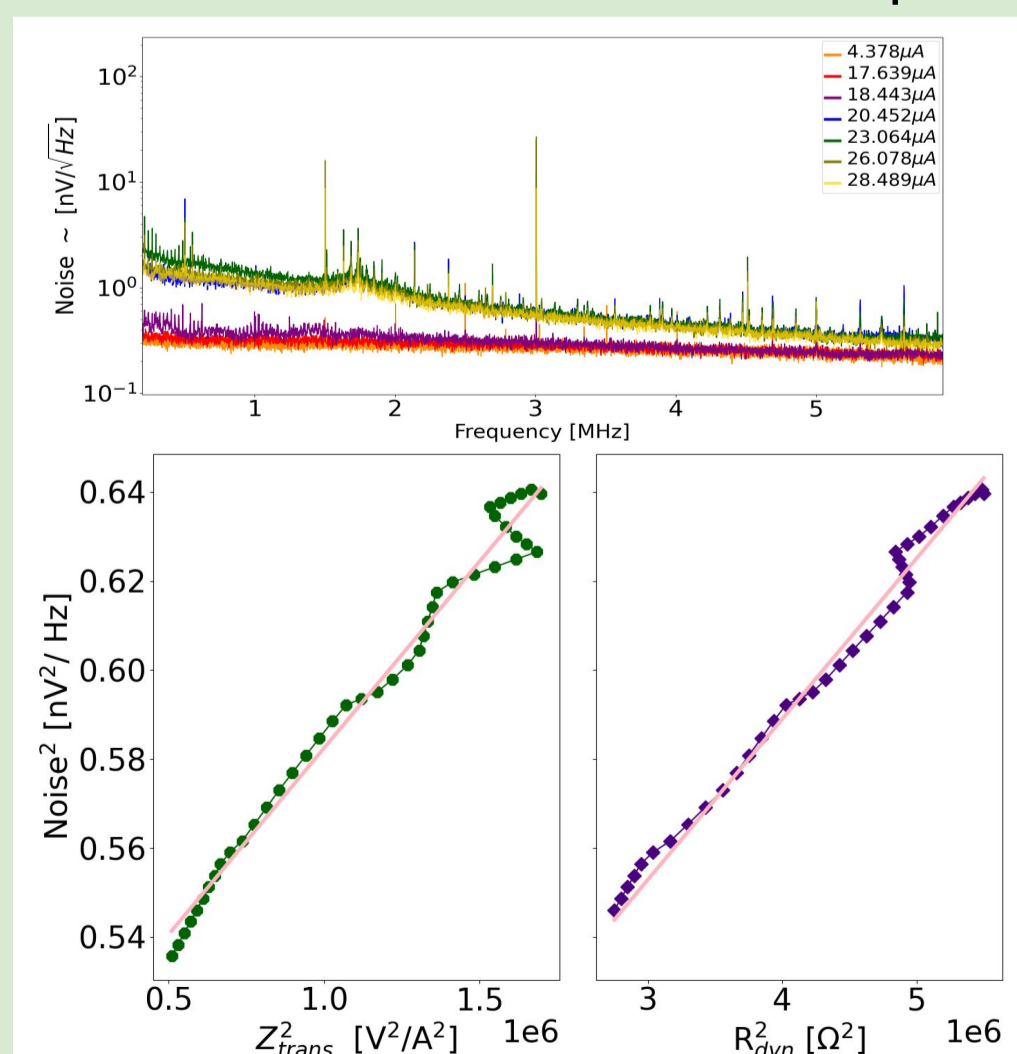

Measured noise of the complete SQUID readout for different SQUID biasing current (upper panel) and its dependency from biasing point parameters (lower panel).

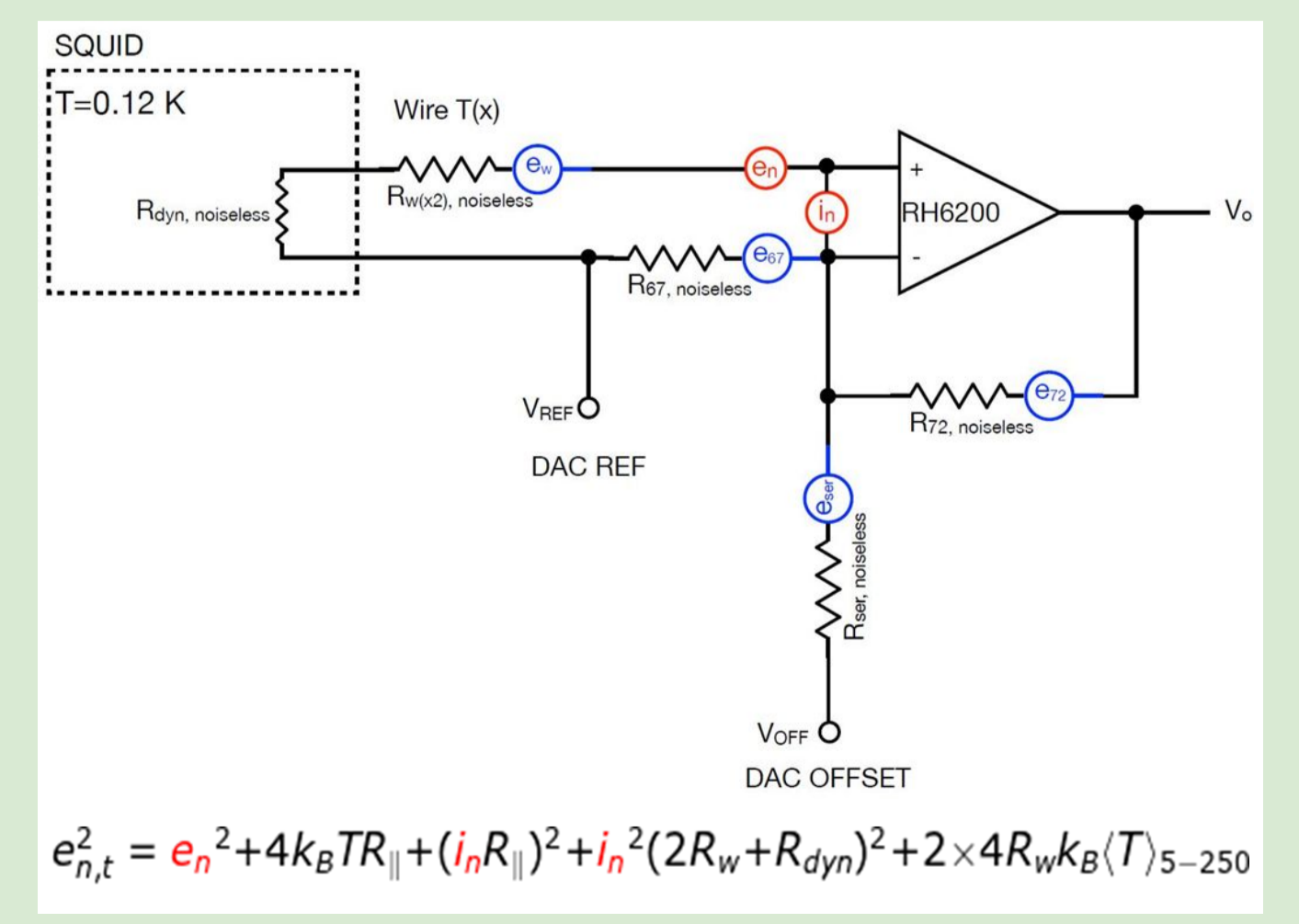

Schematic model of the noise in the read-out chain, with contributions from different sources.

**References:**  
[1] LiteBIRD Collaboration, PTEP 2023 (2023) no.4, 042F01 doi:10.1093/ptep/ptac150

**Contacts:** paolo.dalbo@unitn.it

**Acknowledgements:**

The project is supported by the Italian Space Agency (ASI) and the National Institute for Nuclear Physics (INFN)