

The PRISMA spectrometer

A brief introduction

F. Galtarossa, INFN Padova
franco.galtarossa@pd.infn.it



Outline

- What kind of reactions can we study with PRISMA?
- Characteristics of the PRISMA spectrometer
- The different PRISMA detectors
- Main steps of PRISMA analysis
- PRISMA ancillaries (except for AGATA)
- Some recent (small) upgrades

MNT reactions at near-barrier energies

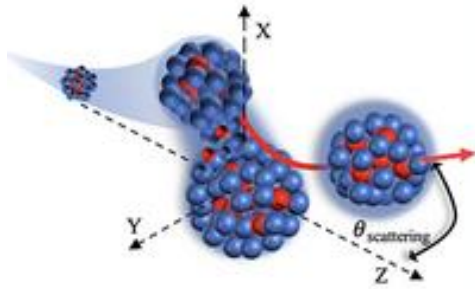

Angular distributions peaked at the grazing angle

Reaction products close to the reactants

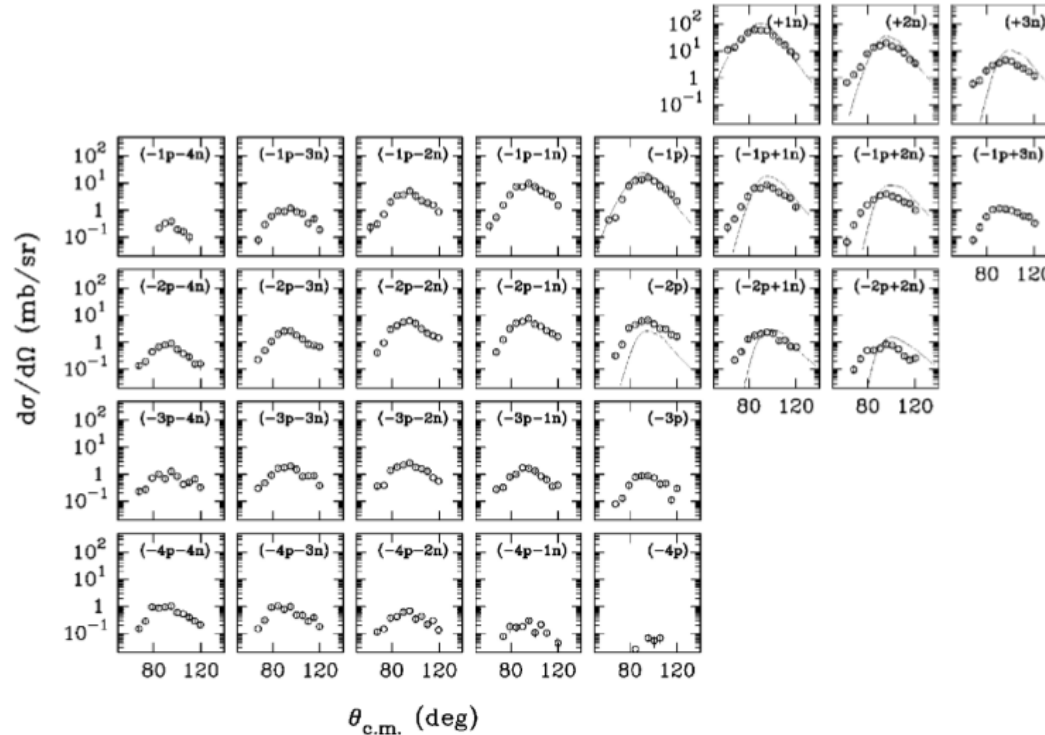

L. Corradi et al., Phys. Rev. C **59** (1999) 261

Increasing energy loss components as more nucleons are transferred

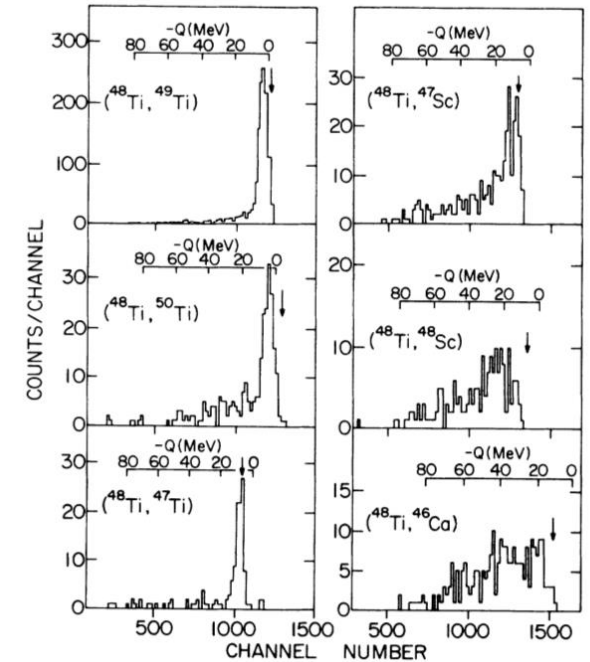

K. E. Rehm et al., Phys. Rev. C **37** (1988) 2629

Typical bombarding energies: few MeV/u

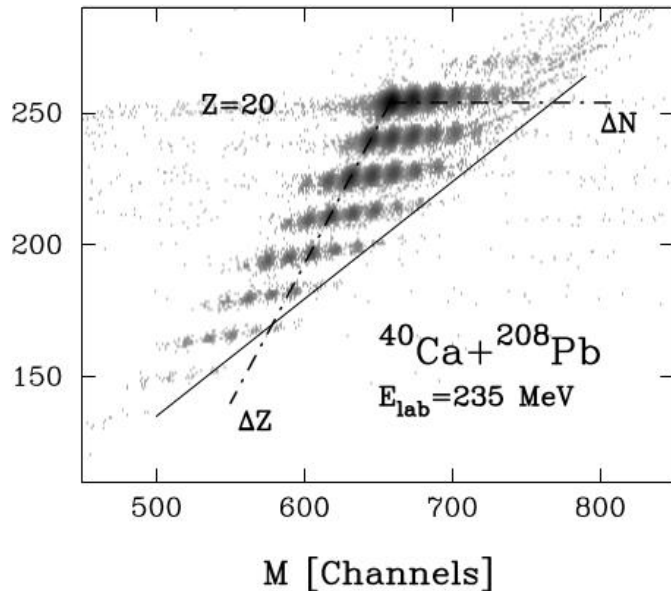

S. Szilner et al., Phys. Rev. C **71** (2005) 044610

The AGATA-PRISMA commissioning

Multinucleon transfer reaction

$^{32}\text{S} + ^{124}\text{Sn} @ 160 \text{ MeV}$

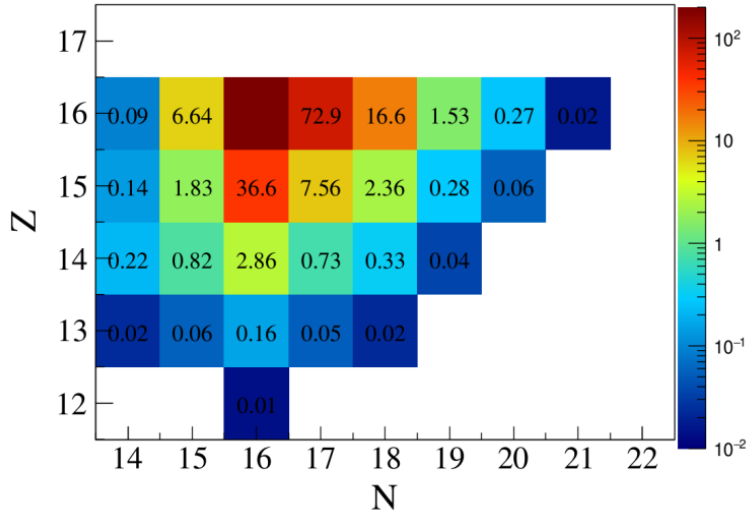

Nuclear charge identification

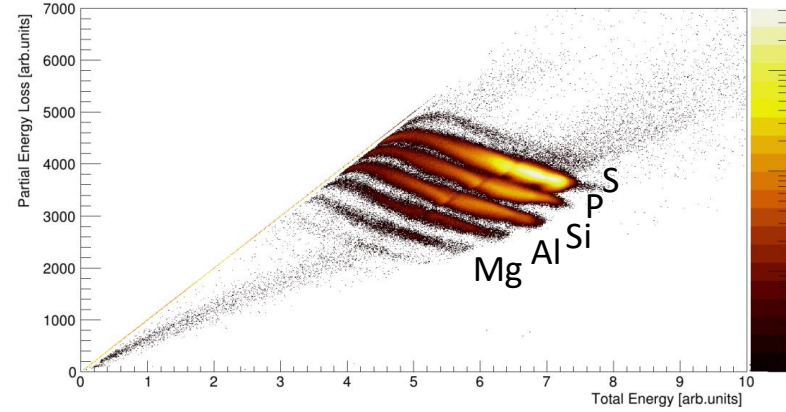

Mass identification

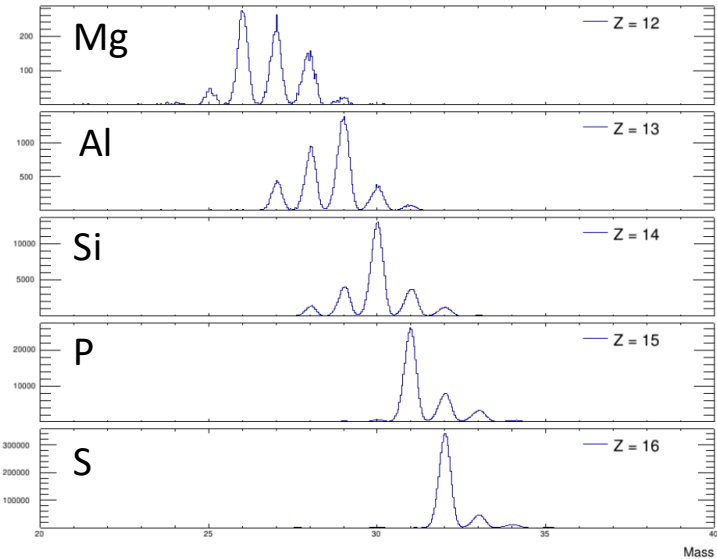

Event-by-event
Doppler
correction

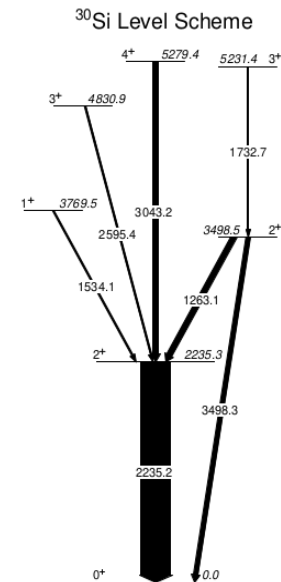
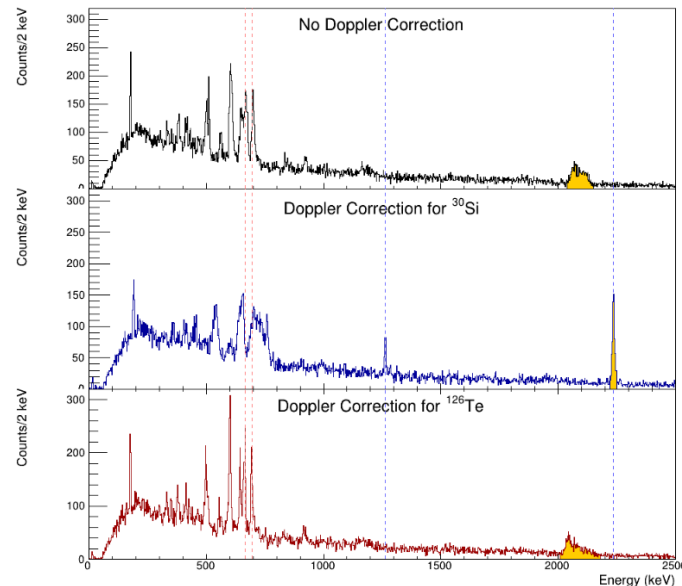

Use the Q value
to control n-
evaporation

Spectroscopy or
lifetime
measurements

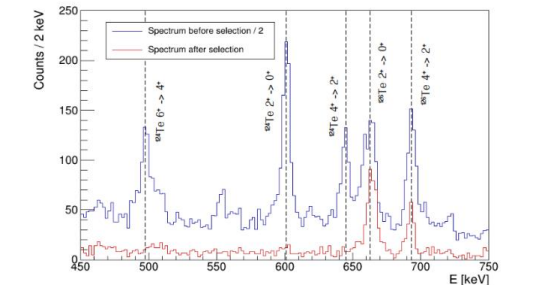
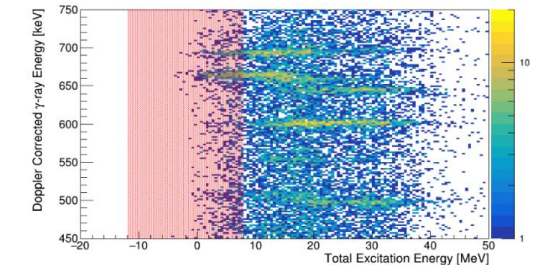

E. Pilotto, Master Thesis,
Università di Padova (2022)
F. Angelini, Master Thesis,
Università di Padova (2022)

Trajectory reconstruction

$$30 < A < 140$$

$$15 < Z < 60$$

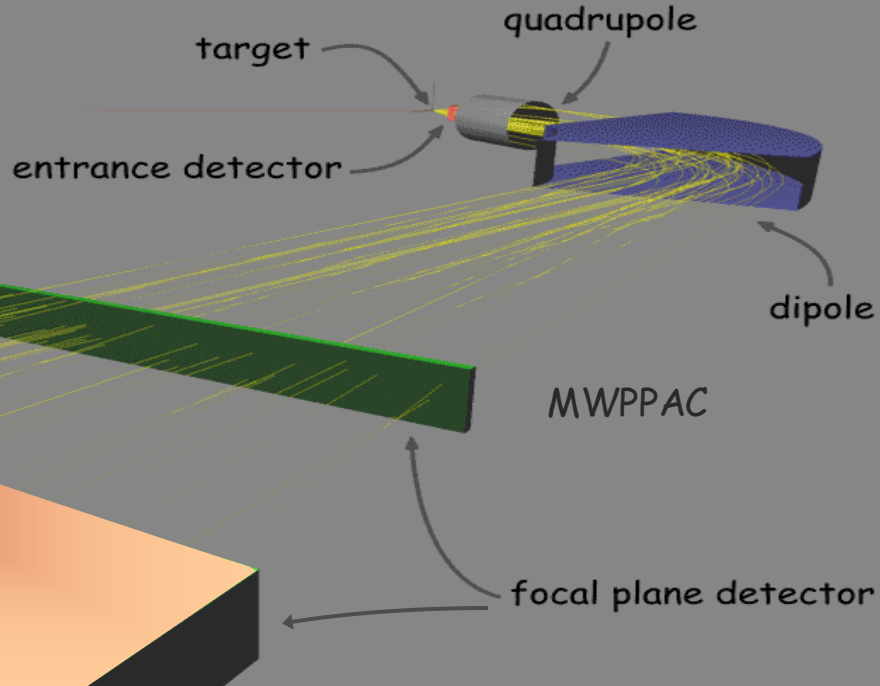

A physical event is composed of:

- Entrance position $(x,y) \rightarrow (\theta,\phi)$
- Position at the focal plane (x',y')
- Time-of-Flight (ToF)
- Energy $(\Delta E-E)$

MCP detector
 MWPPAC detector
 Δt MCP-MWPPAC
 Ionization Chamber

Solid angle $\Delta\Omega$	~ 80 msr
Angular acceptances	$\Delta\theta \approx \pm 6^\circ; \Delta\phi \approx \pm 11^\circ$
Energy acceptance	$\pm 20\%$
Momentum acceptance	$\pm 10\%$
Mass resolution	$\Delta A/A \approx 1/300$
Nuclear charge resolution	$\Delta Z/Z \approx 1/60$
Maximum $B\rho$	~ 1.2 Tm
Dispersion	$\Delta p/p \approx 4$ cm/%
Distance target-FPD	~ 6.5 m
IC Energy resolution	$\sim 1\%$
MCP and MWPPAC x,y position resolutions	~ 1 mm
MCP and MWPPAC timing resolutions	~ 350 ps
Maximum rate at the FP	~ 3 kHz
θ_{PRISMA} (AGATA standard position)	$20^\circ < \theta < 88^\circ$
θ_{PRISMA} (AGATA close position)	$35^\circ < \theta < 88^\circ$

Trajectory reconstruction

X, Y entrance position -> Mass resolution, Q-value resolution, Doppler correction

ToF and position resolution -> Mass resolution, Doppler correction

ToF offset determination -> Doppler correction

Z resolution -> Atomic number identification

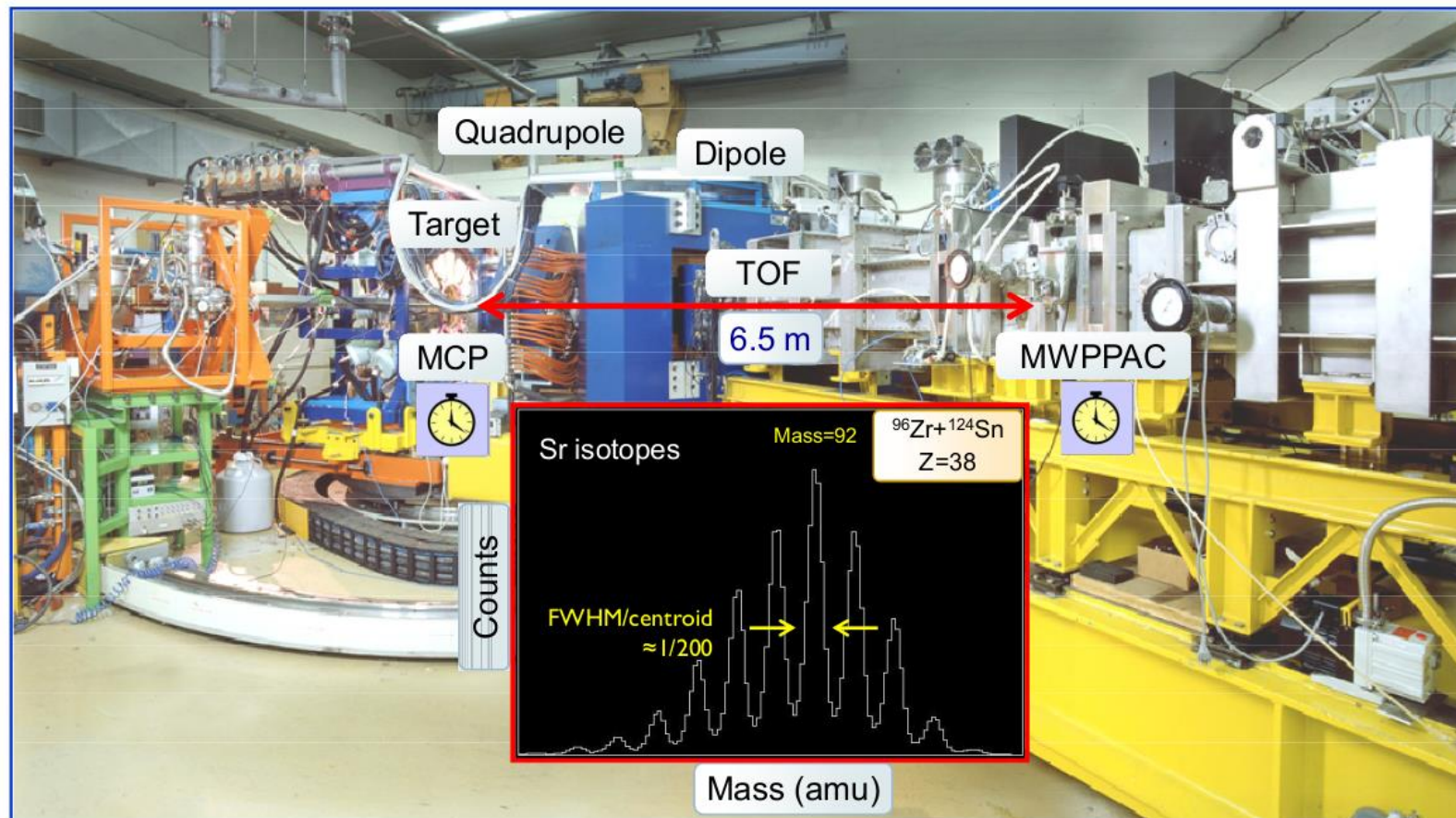

PRISMA detectors

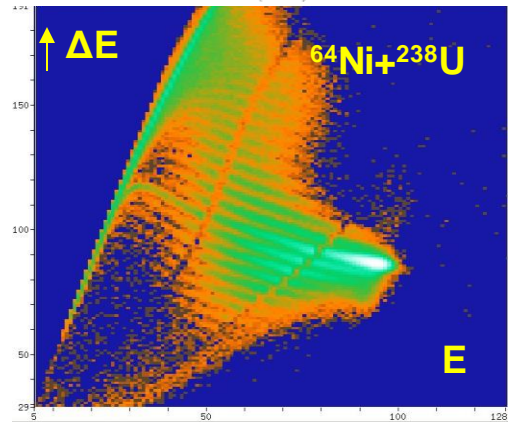
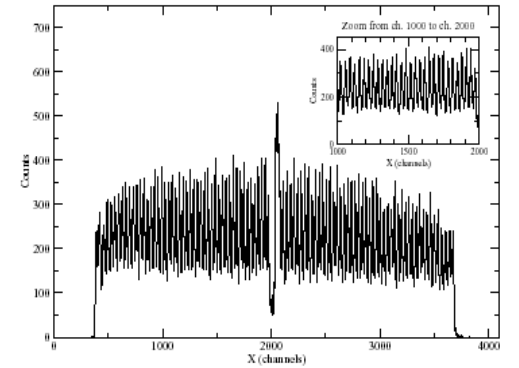
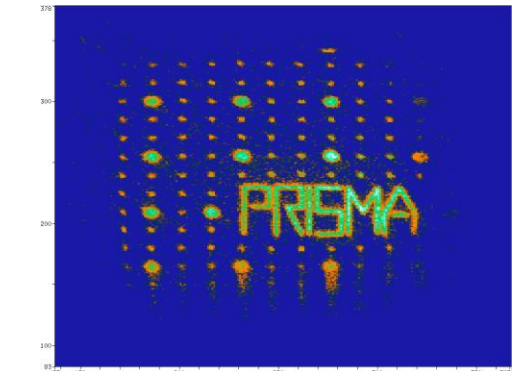
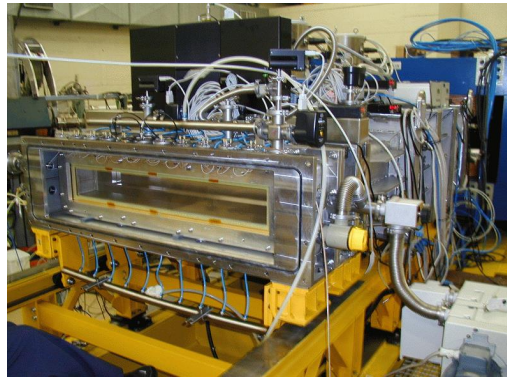
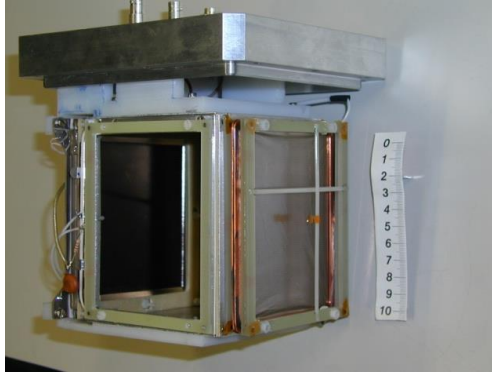
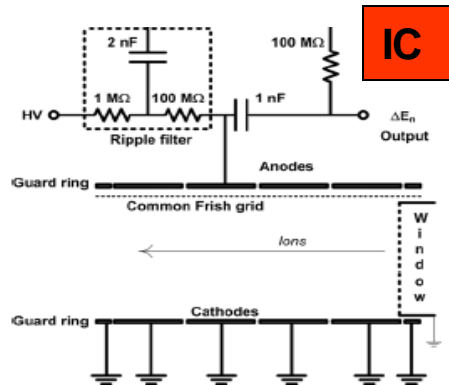
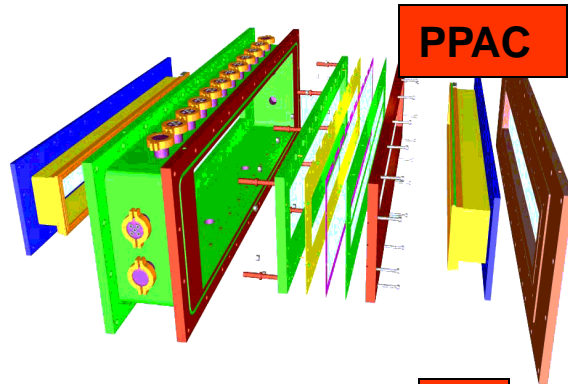
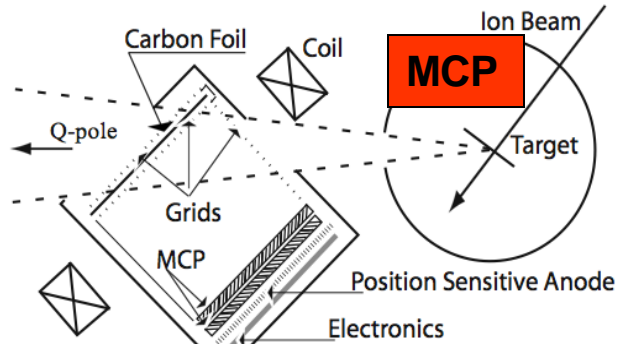

PRISMA MCP

- Active area: $8 \times 10 \text{ cm}^2$ ($\Omega = 80 \text{ msr}$)
-> full coverage of PRISMA spectrometer at $d = 25 \text{ cm}$ from target
- Timing resolution for TOF $\sim 350 \text{ ps}$
- C foil: $20 \mu\text{g}/\text{cm}^2$ thick (100 nm!)
- $E_{\text{acc}} = 30\text{-}40 \text{ kV}/\text{m}$
- Parallel magnetic field: $B \sim 120 \text{ G}$ to limit the spread of electron cloud preserving particle position information
- 3 signals: X, Y, time

For the analysis: only 2 signals for the MCP (X, Y)

G. Montagnoli et al., NIM A **547** (2005) 455-463

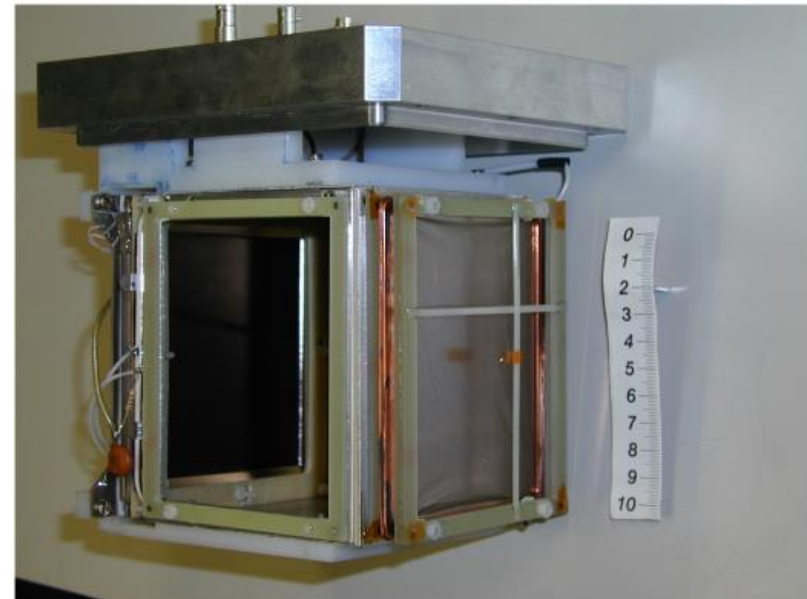
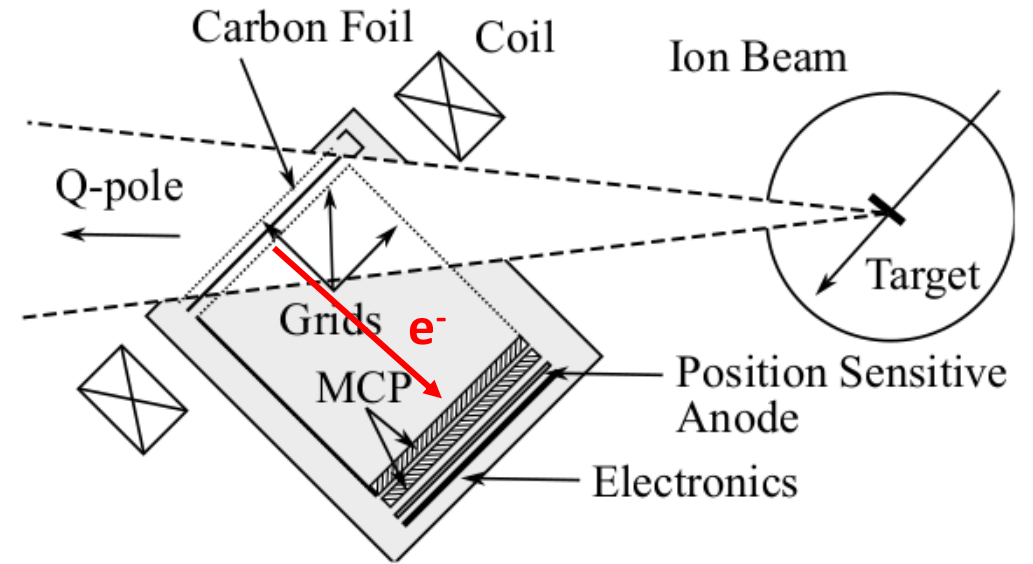

PRISMA MCP

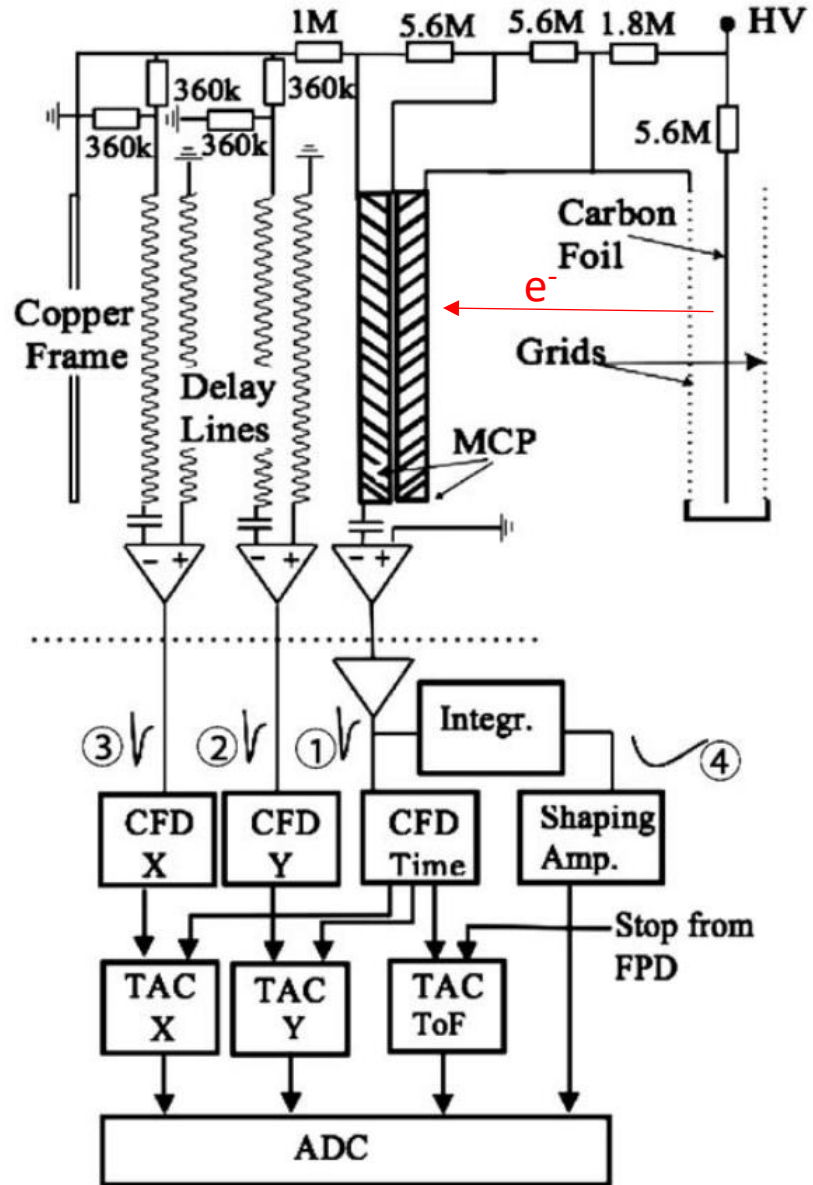

Raw MCP matrix

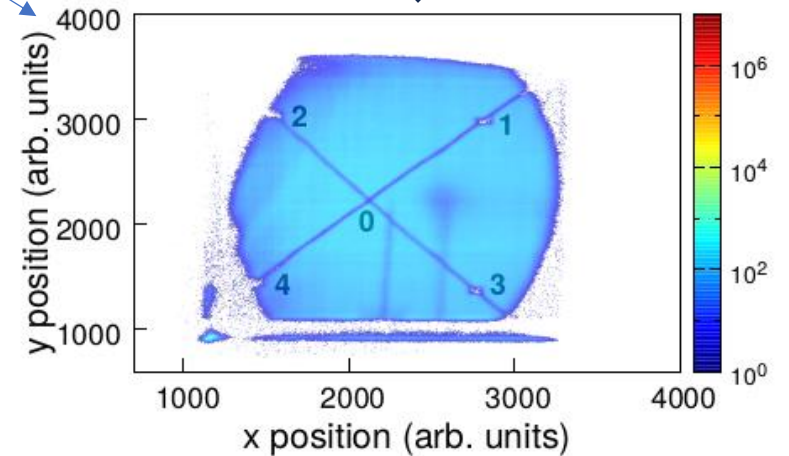
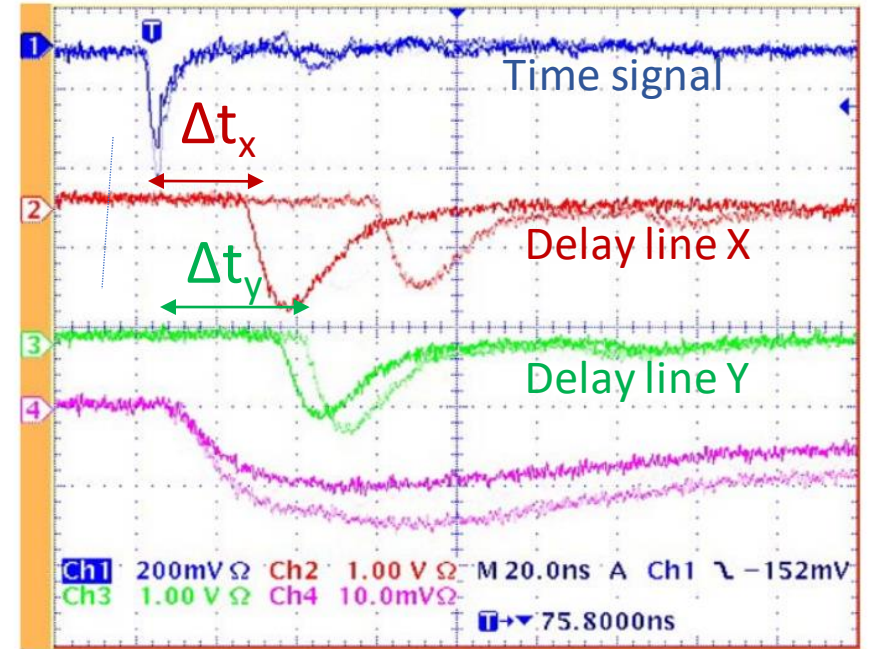

Focal Plane Detector

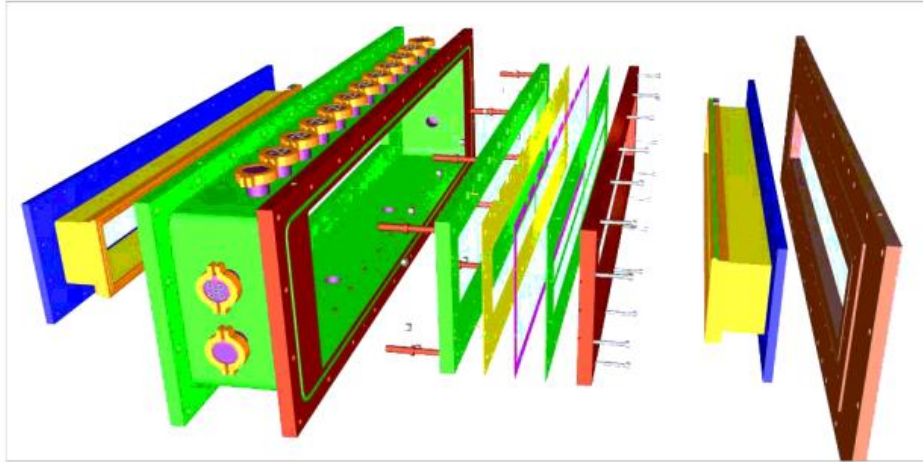

S. Beghini *et al.*
NIM **A551** (2005) 364

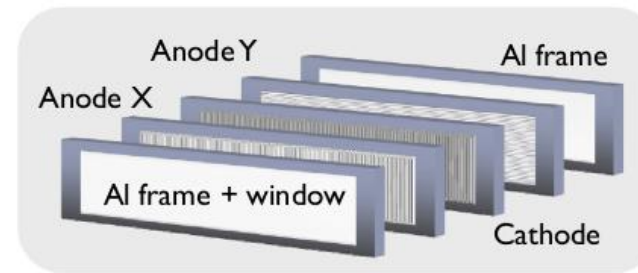

- **Active area:** 100 cm x 13 cm
- **3 electrode structure:** central cathode + 2 anode wire planes (X and Y) $d_{A-C} = 2.4$ mm
- **cathode:** 3300 wires of 20µm gold-plated tungsten - 0.3 mm spacing - 10 independent sections of 10x13 cm² negative high voltage: 500-600 V
- **X plane:** 10 sections of 100 wires each, 1mm spacing
- **Y plane:** common to all cathode, 130 wires, 1 m long, 1mm steps
- **spatial resolution:** $\Delta X \sim 1$ mm, $\Delta Y \sim 2$ mm (FWHM)
- **stop signal for TOF**
- **10 x 3 signals** (X_{left} , X_{right} , timing) **2 signals** (Y_{up} , Y_{down})
- **Filling gas:** C₄H₁₀ **Pressure:** 7 mbar

MWPC (Multi-Wire Proportional Chamber)

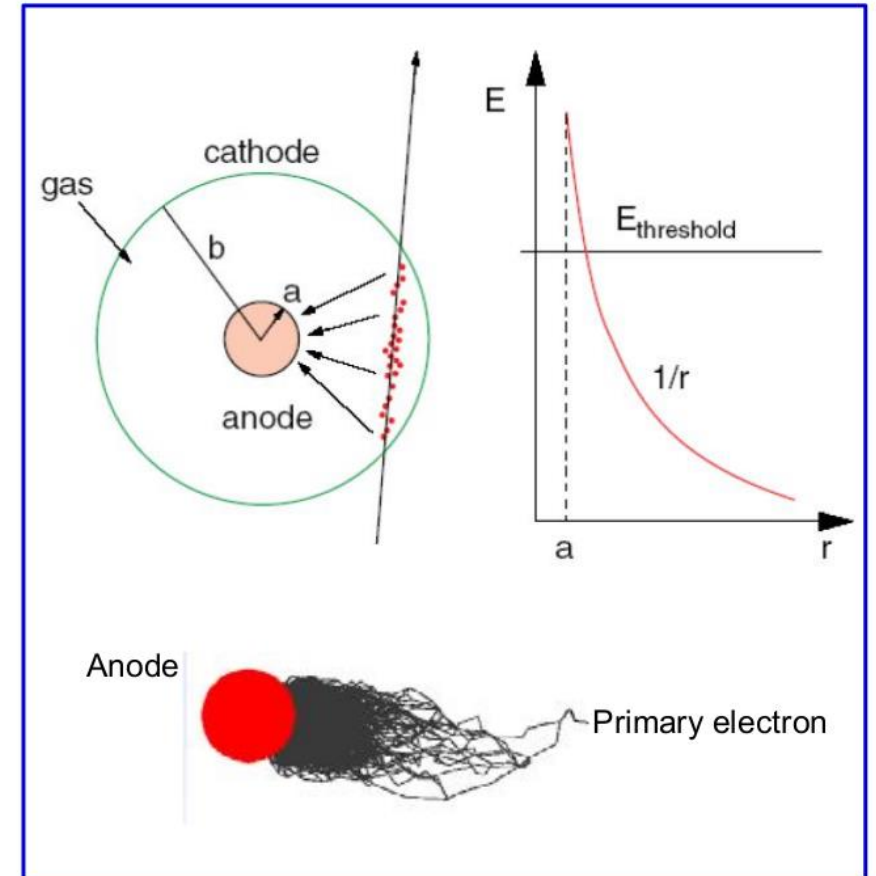
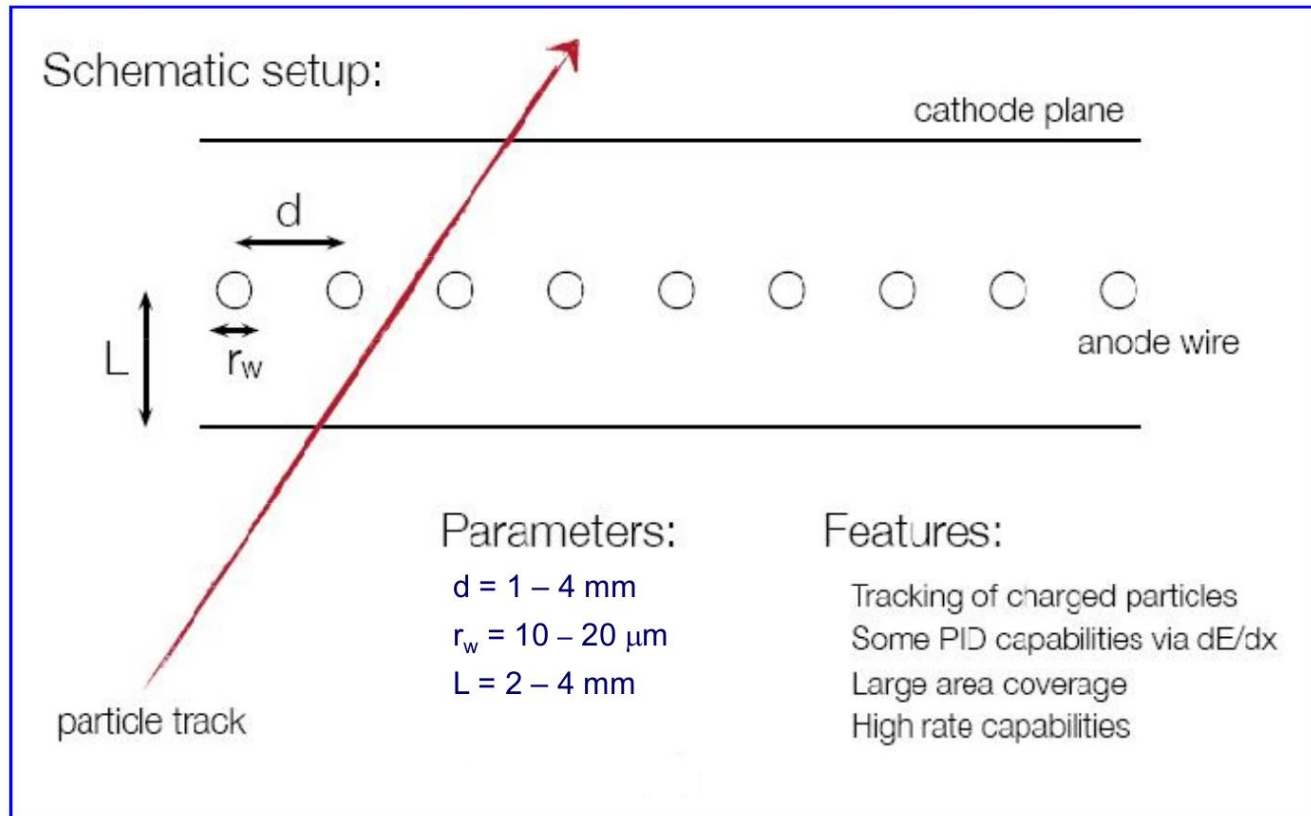

PRISMA MWPPAC

For the analysis: 42 signals for the PPAC!



MWPPAC

Fabio

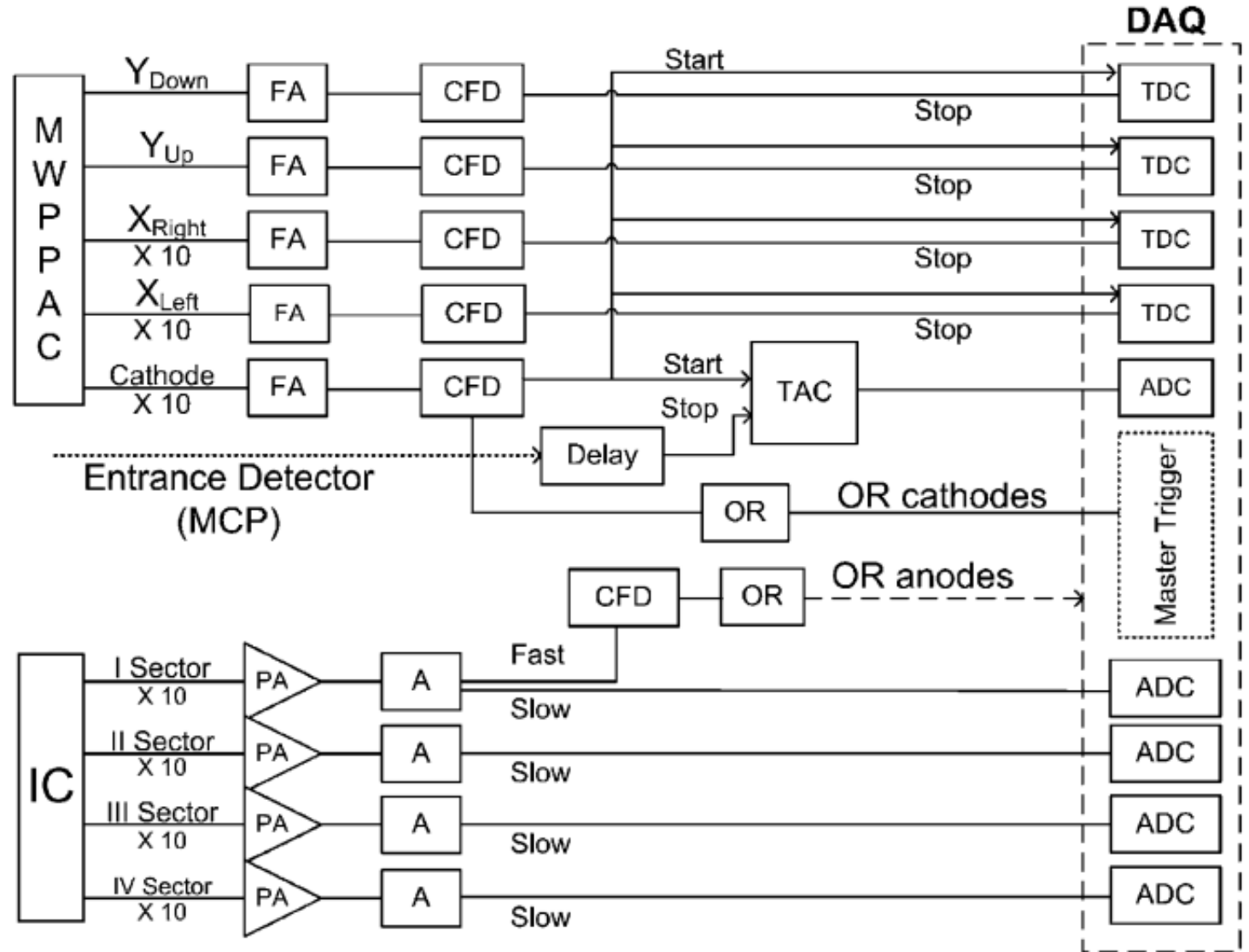

PRISMA MWPPAC

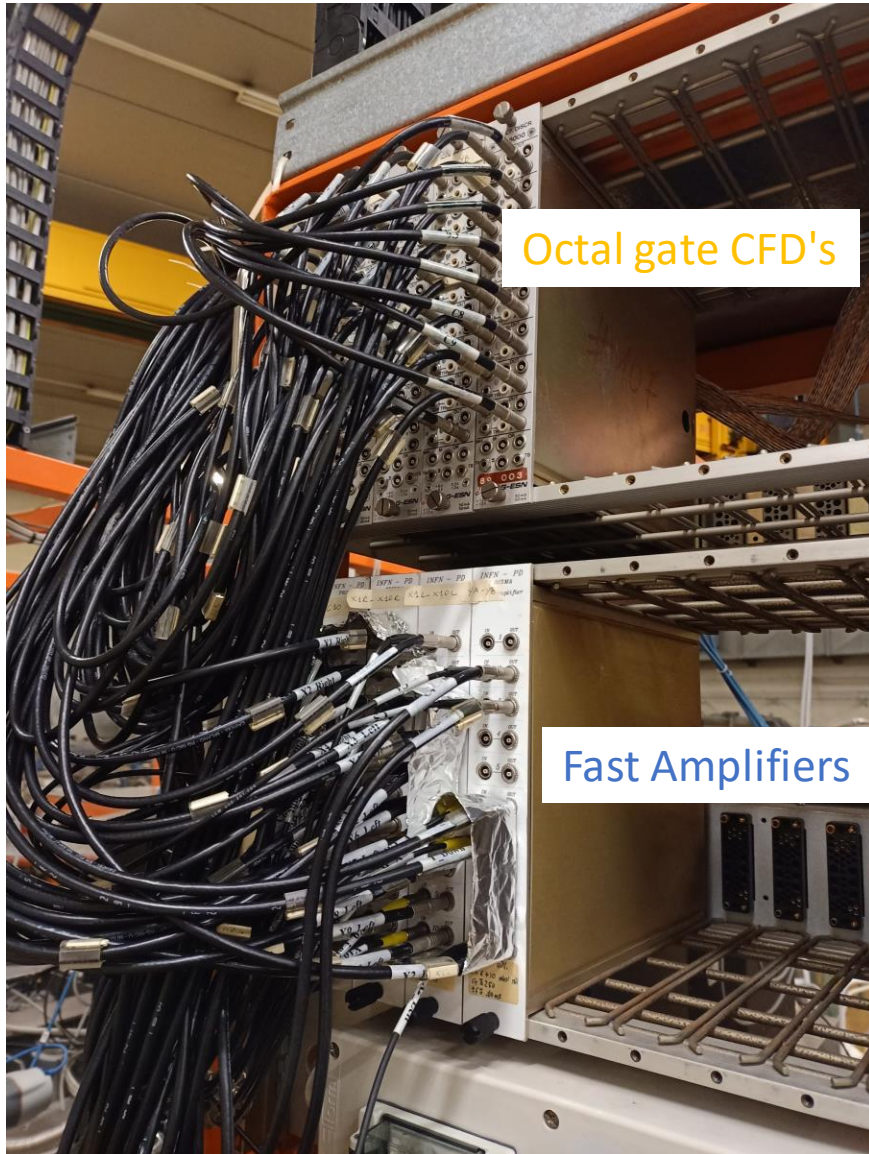

TAC's for ToF determination

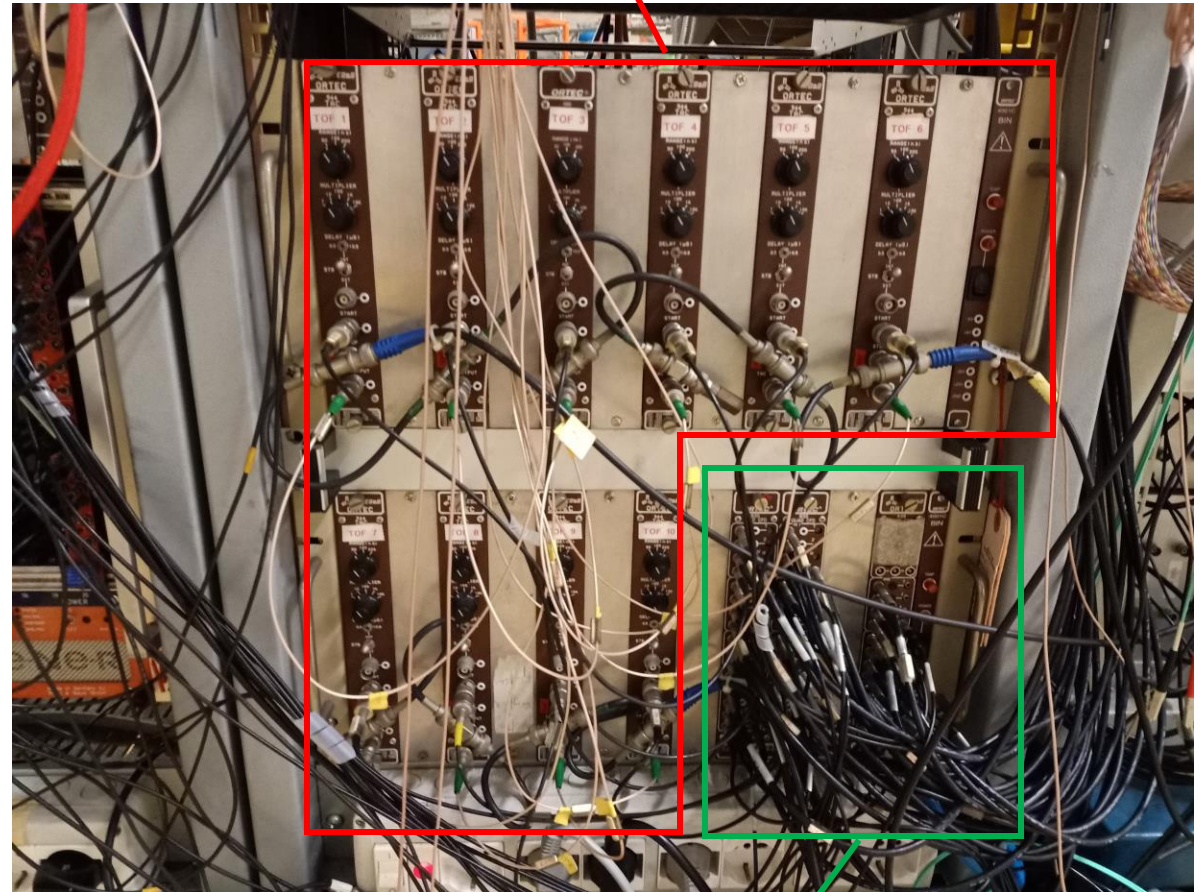

CFD's for timing signals from the cathode

PRISMA IC

Multi-anode transverse field IC

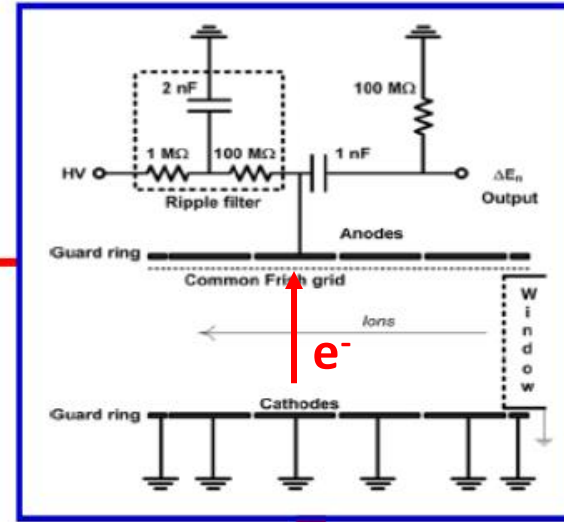
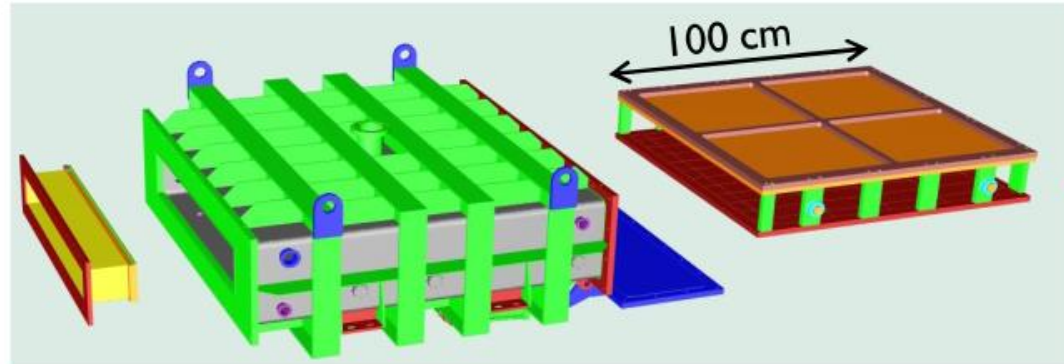

10x4 sections
10x25 cm²

E. Fioretto et al.
LNL Ann. Rep. 2002, p.148

$\Delta E/E < 2\%$
 $\Delta Z/Z \sim 1/60$ for $Z=20$

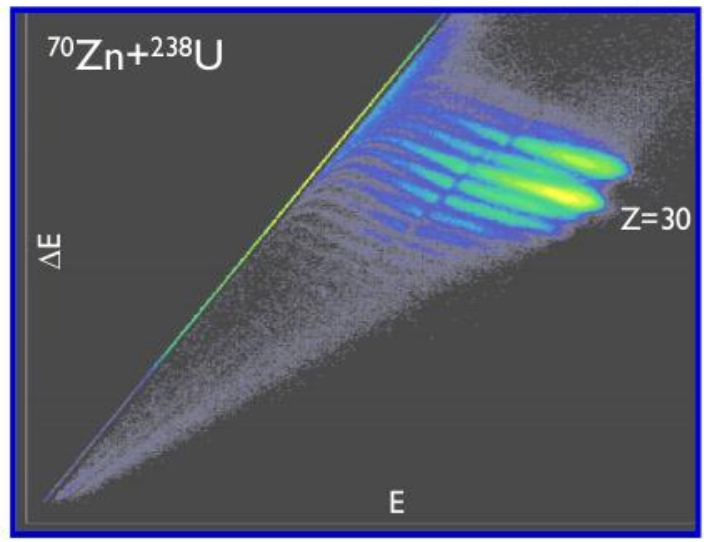

PRISMA IC

Pre-amplifiers on top of the IC

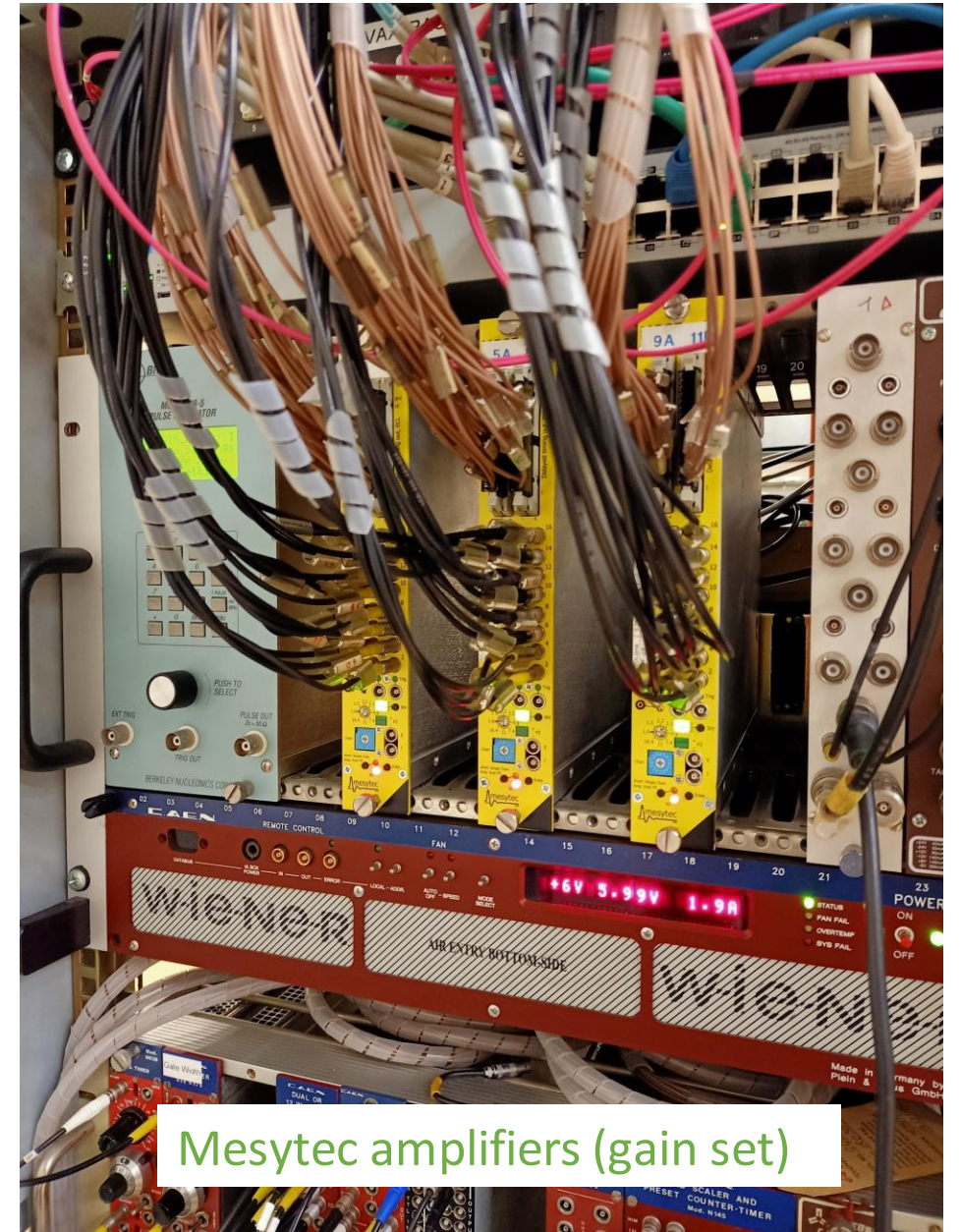
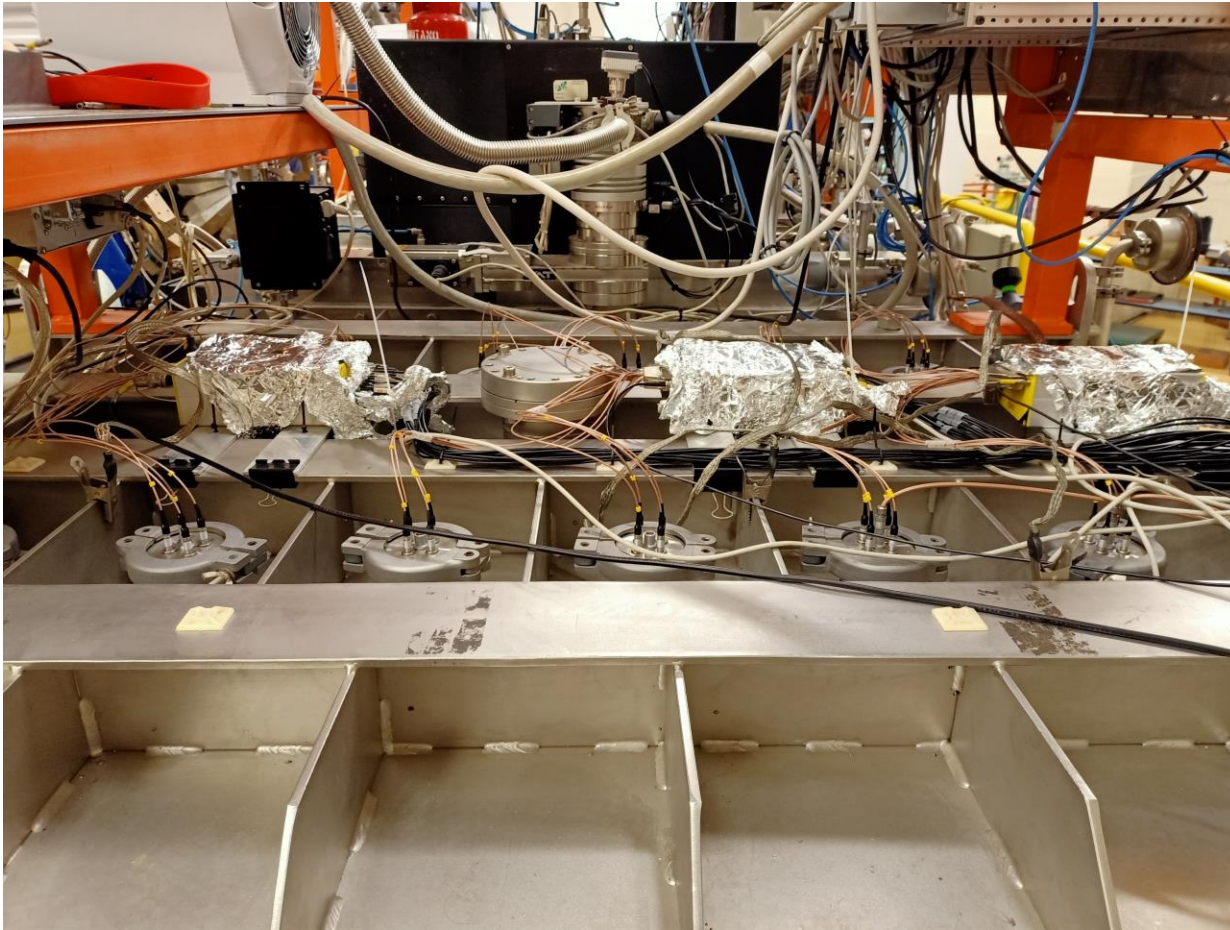

Mesytec amplifiers (gain set)

Nuclear charge identification

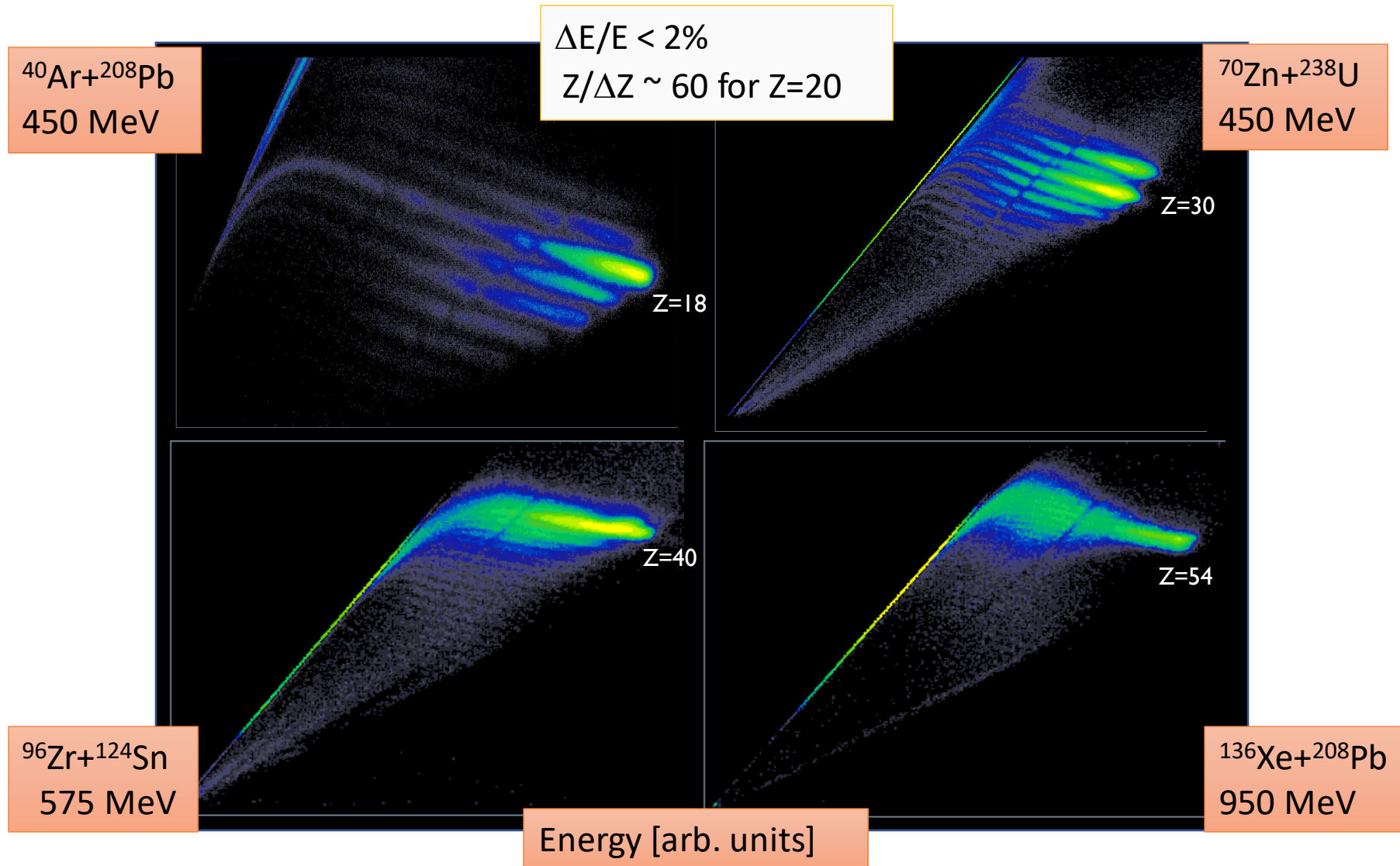

Mass resolution obtained after trajectory reconstruction

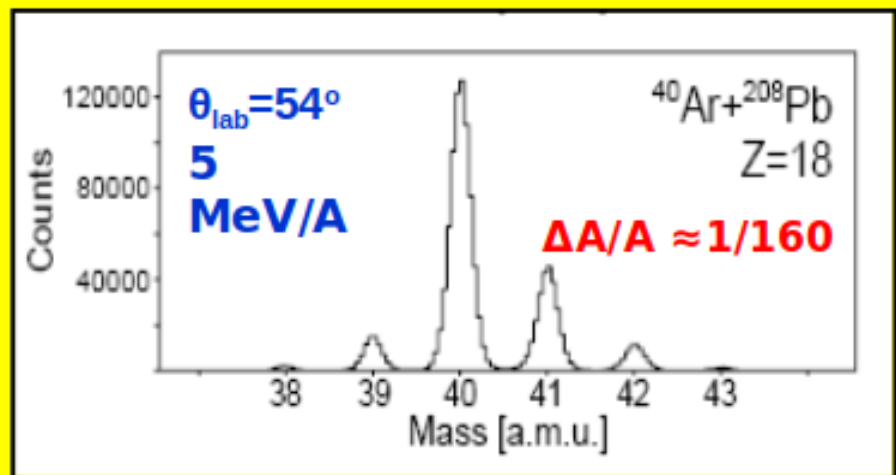
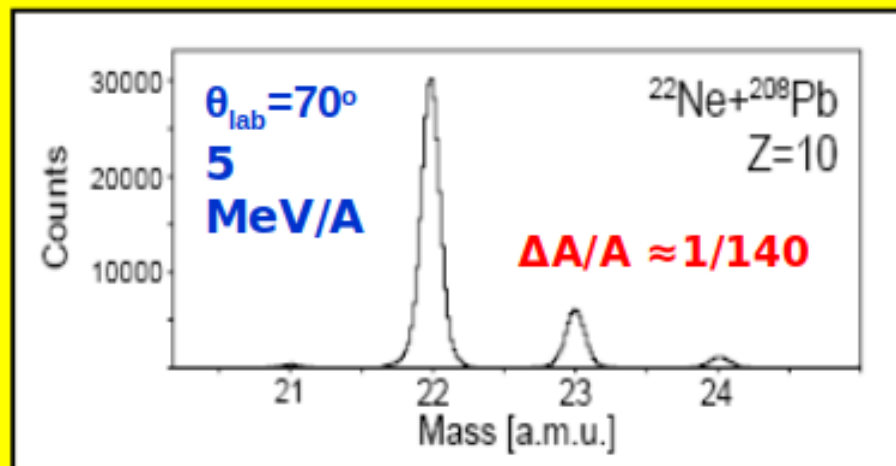

the obtained mass resolutions for the different ions are close to the values expected taking into account detector resolutions (positions and timing)

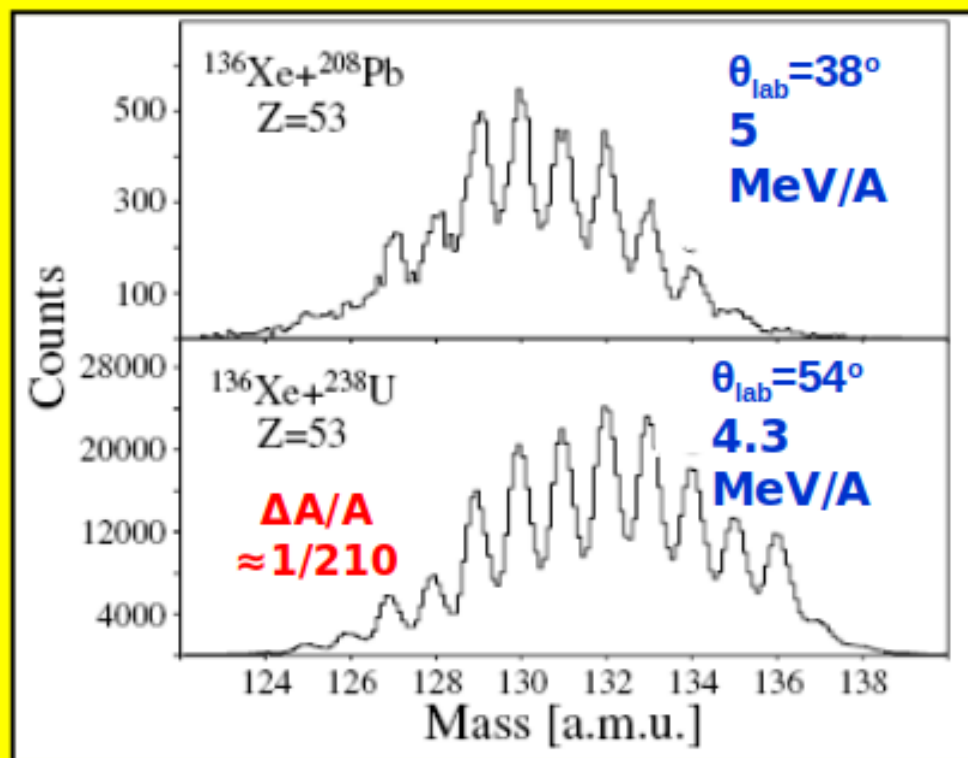

Cross section sensitivity

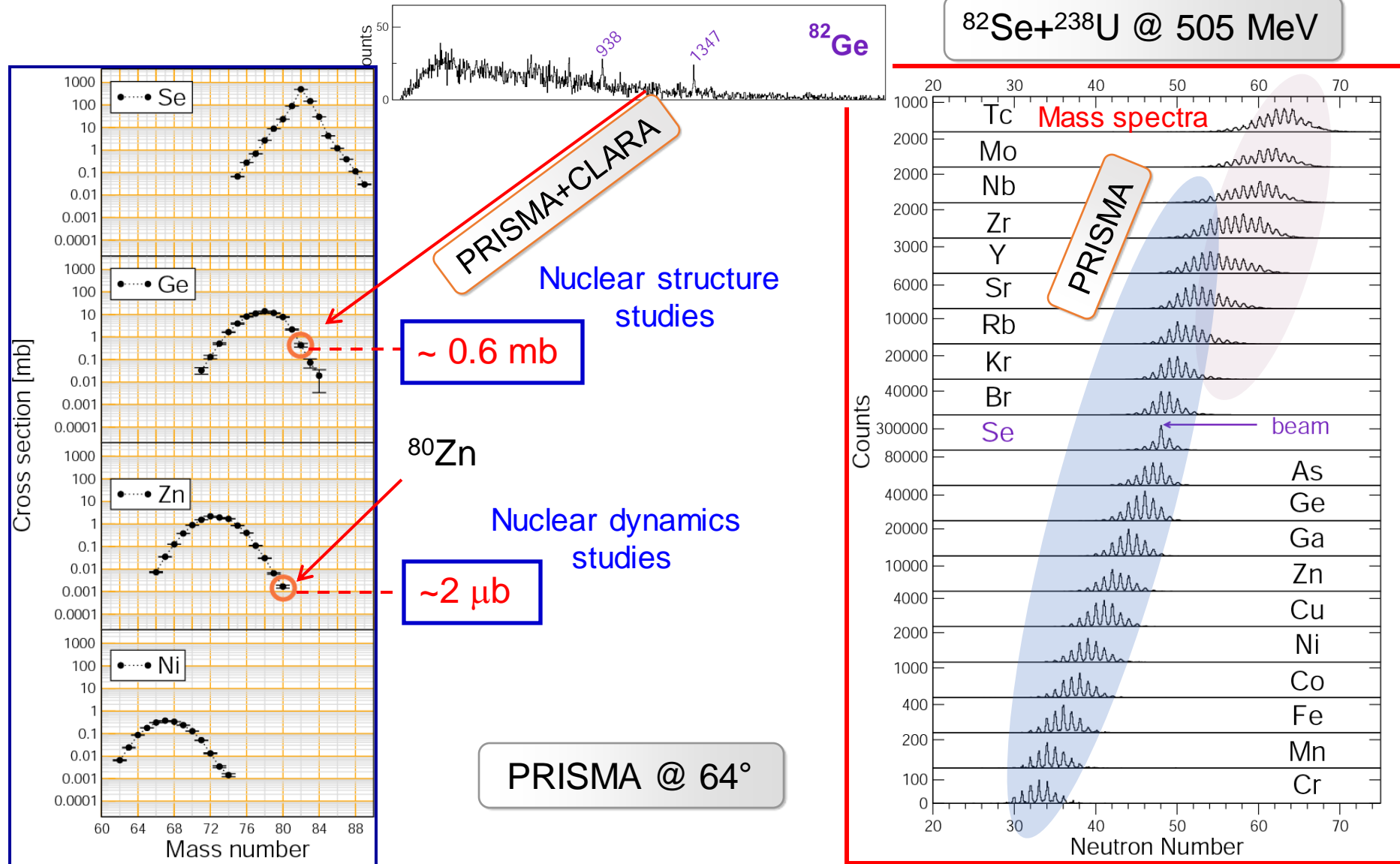

Analysis steps

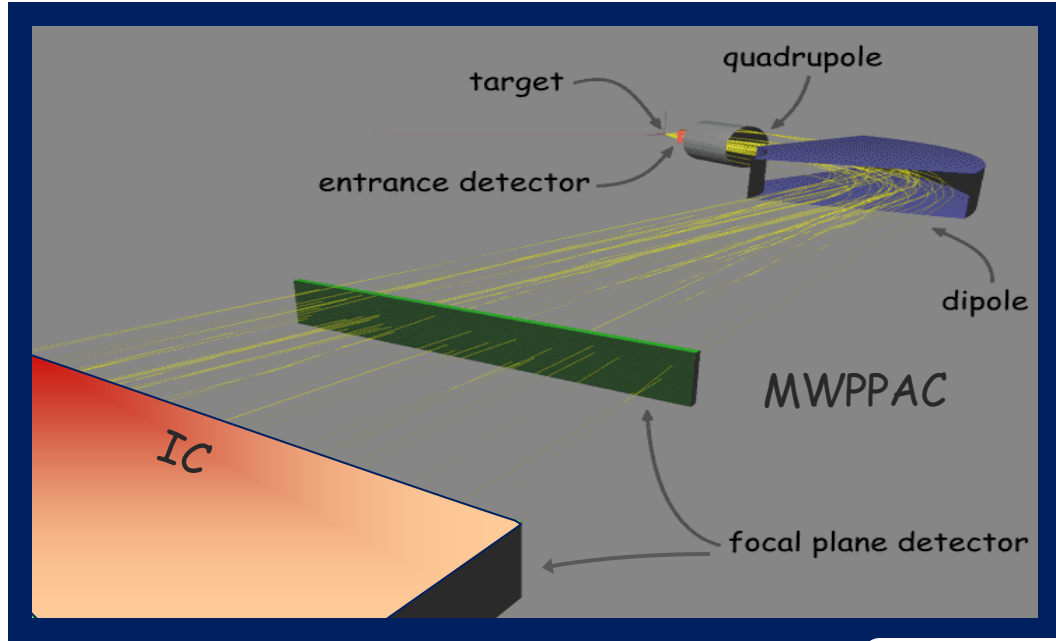

A physical event is composed by the parameters:

- position at the entrance x, y
- position at the focal plane X, Y
- time of flight TOF
- energy $\Delta E, E$

Courtesy of
T. Mijatović

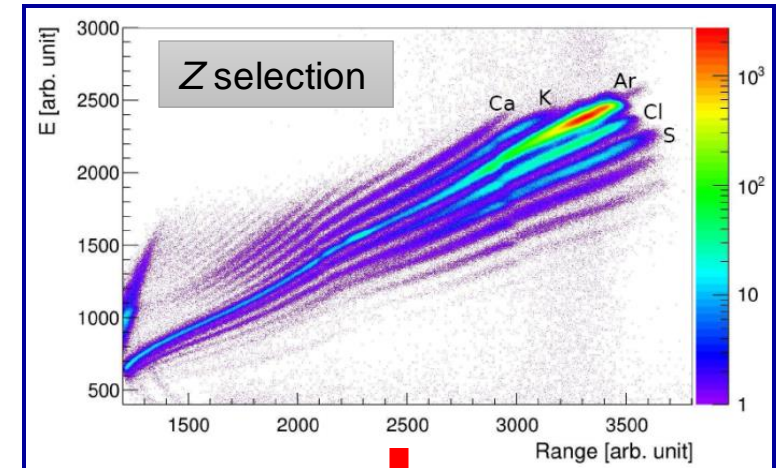

$^{40}\text{Ar} + ^{208}\text{Pb}$ @ 260 MeV

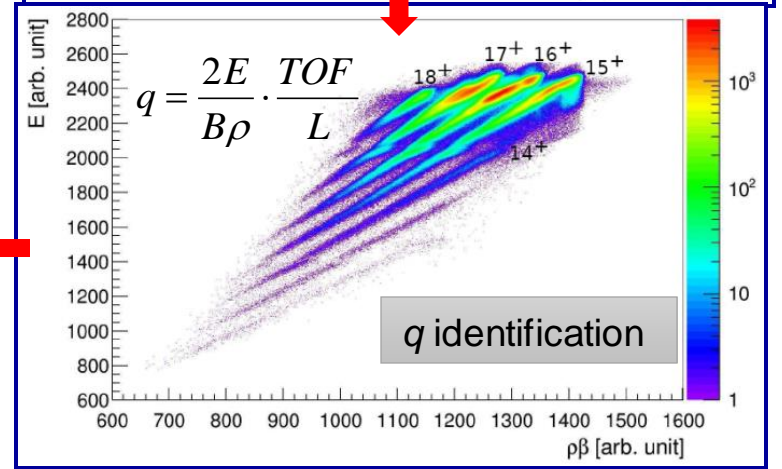
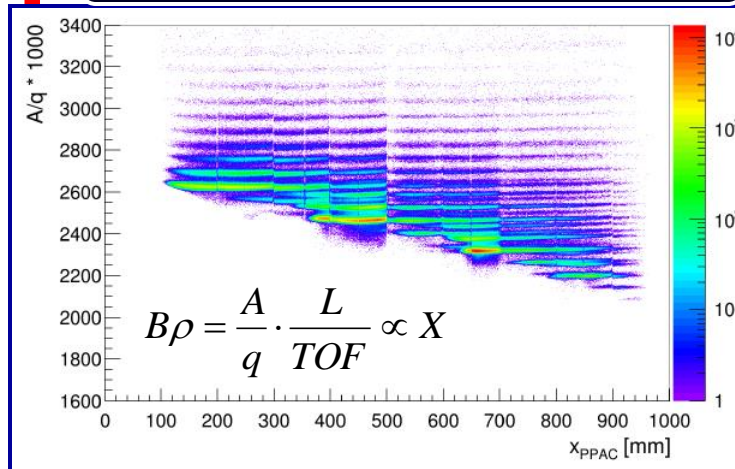
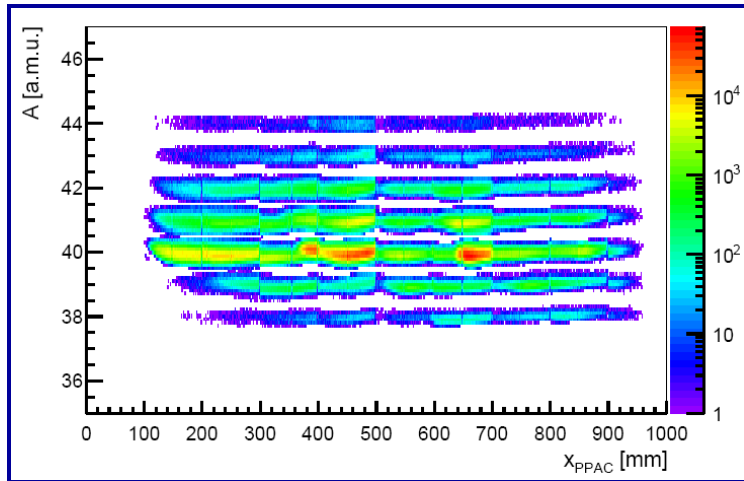

Analysis steps

1. Check thresholds and 2D gates (MCP, MWPPAC)
2. Set Z gates in the E- ΔE matrix
3. Set the ToF offset and align the MWPPAC sections in ToF
4. Set Q gates in the E-R β matrix
5. Calibrate the A/Q (assign a mass to each A/Q)
6. Apply the calibration to sum the different Q and obtain the mass spectra
7. Check with the gamma Doppler correction how well you set the ToF
8. Repeat from point 3 an indefinite number of times
9. Further processing to improve resolutions -> Expert mode!

Structure of PRISMA data

Array called *theMap*[240]:

- 0-59 for MCP (but only 3 used, 0: X; 1: Y)
 - 60-119 for MWPPAC (all used but the yup and ydown are repeated)
- 0: Yup; 1: Ydown; 2: Xleft; 3: Xright; 4: Cathode; 5: ToF
- 120-179 for IC (40 used -> 10 pads x 4 sections)
 - 180-239 for IC Sides (8 used)

These numbers can be seen in the Look-Up Table (LUT).

5	0	168	IC_8_DE_A
5	1	169	IC_8_DE_B
5	2	170	IC_8_DE_C
5	3	171	IC_8_DE_D
5	4	174	IC_9_DE_A
5	5	175	IC_9_DE_B
5	7	176	IC_9_DE_C
5	6	177	IC_9_DE_D
5	8	180	SIDE_0_DE_A
5	9	181	SIDE_0_DE_B
5	10	182	SIDE_0_DE_C
5	11	183	SIDE_0_DE_D
5	12	186	SIDE_1_DE_A
5	13	187	SIDE_1_DE_B
5	14	188	SIDE_1_DE_C
5	15	189	SIDE_1_DE_D
5	16	0	MCP_X
5	17	1	MCP_Y

PRISMA + ancillaries: second arm

PRISMA spectrometer used in high resolution kinematic coincidence with a second time-of-flight system (NOSE)

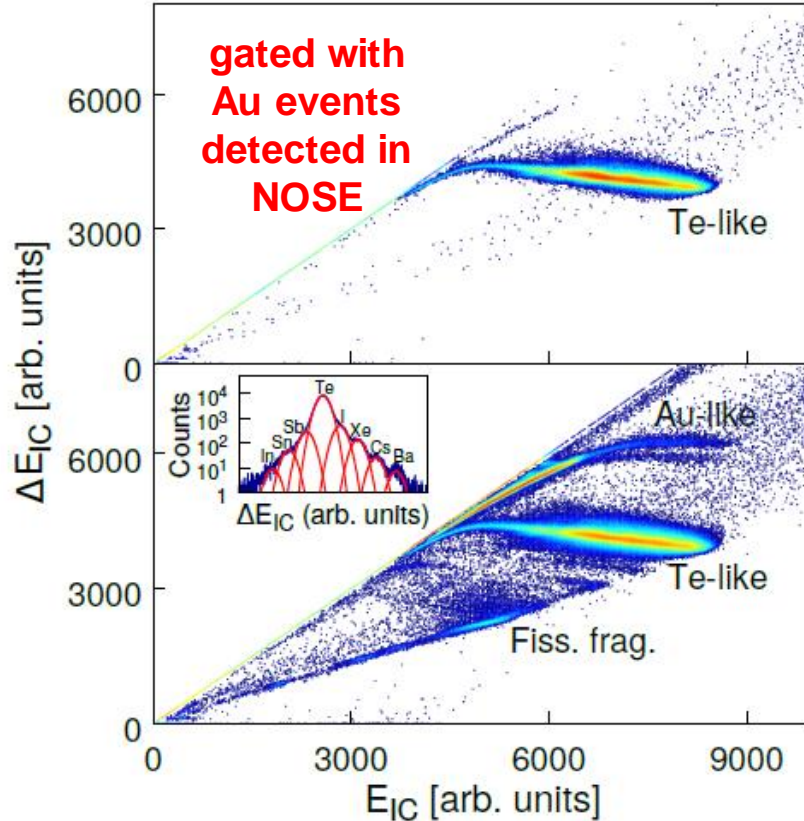

$^{197}\text{Au} + ^{130}\text{Te}$ @ $E_{\text{lab}} = 1.07$ GeV
inverse kinematics

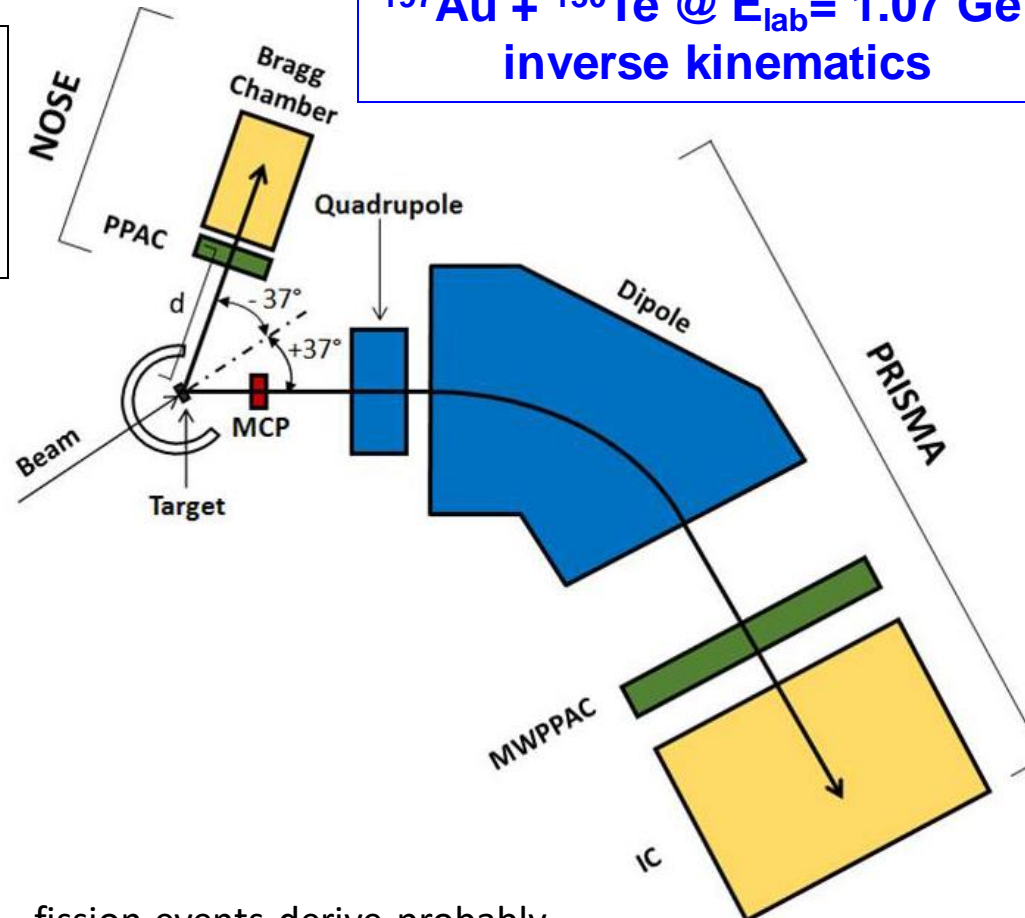

fission events derive probably from transfer induced fission or quasi fission

F. Galtarossa et al., Phys. Rev. C97(2018)054606

PRISMA + ancillaries: DANTE

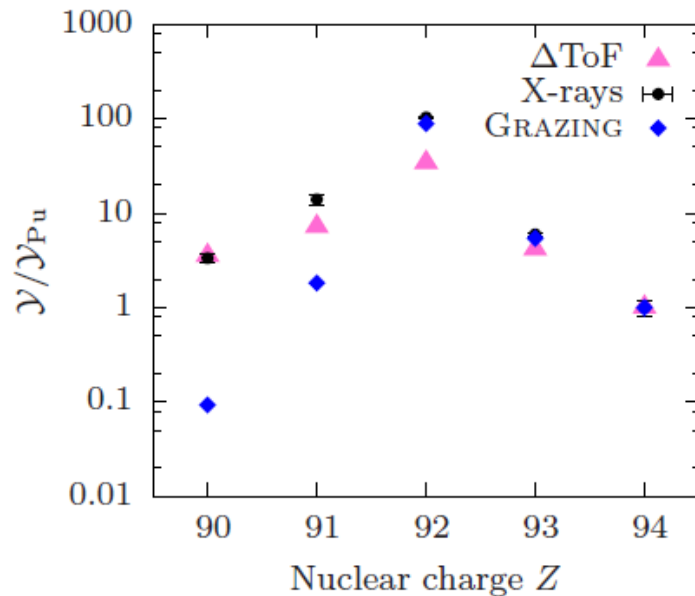
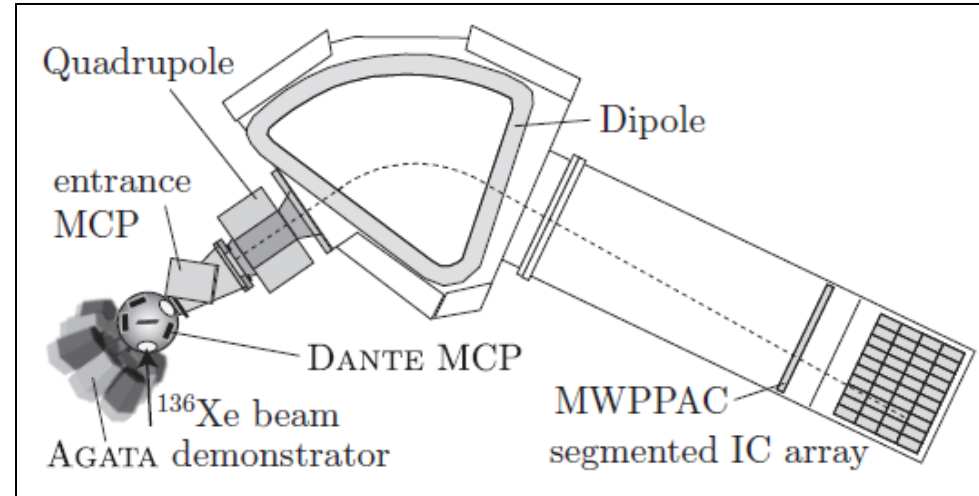
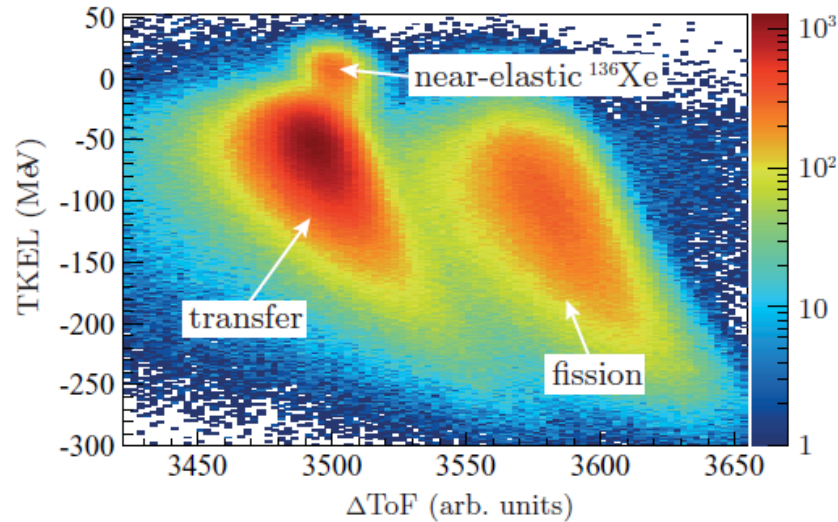

via a kinematic coincidence
PRISMA-DANTE one could
extract the yield of mass
integrated actinide nuclei, which
turns out to be in good
agreement with that derived
from X-ray analysis

TAC drift time spectrum taken
in tests with ^{58}Ni @ 225 MeV

start: MWPPAC cathode
stop: IC anode

Preliminary test performed

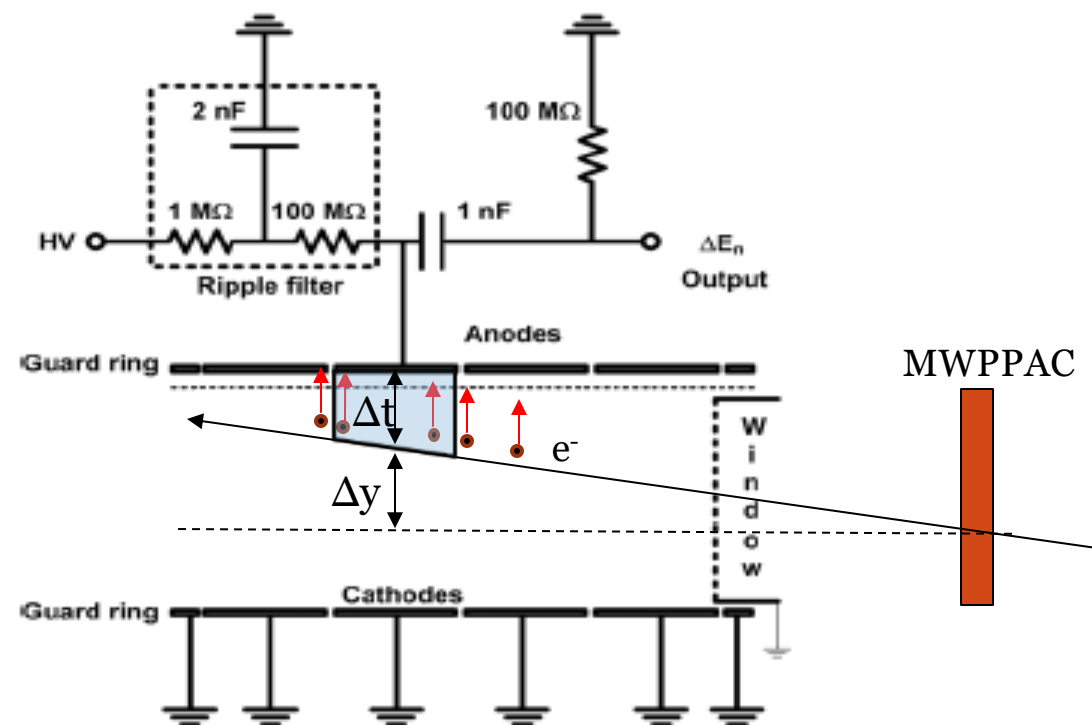
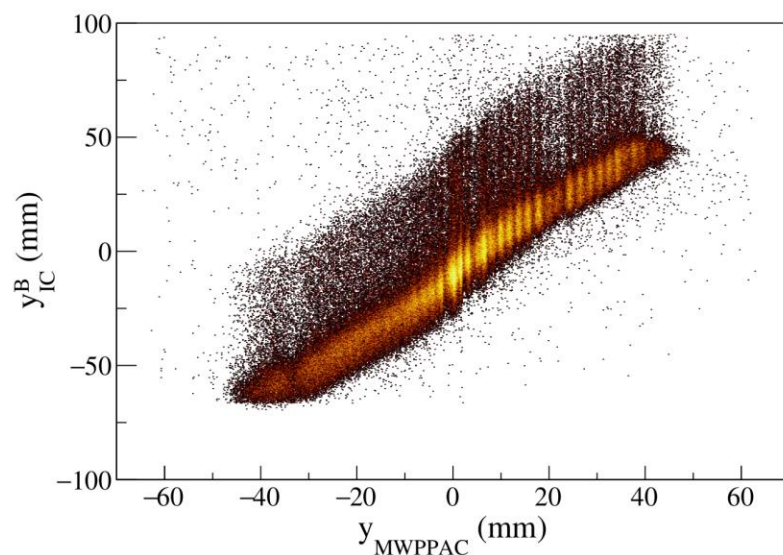

The time difference between the MWPPAC cathode and the IC anode essentially reflects the electrons drift time inside the chamber ($\sim 1\text{-}5 \mu\text{s}$) -> new TDC's with larger range

Information on the **Y coordinate** should help better control the ion trajectories

This information is contained in the IC_drift variable in the PrismaTree (only for some experiments)

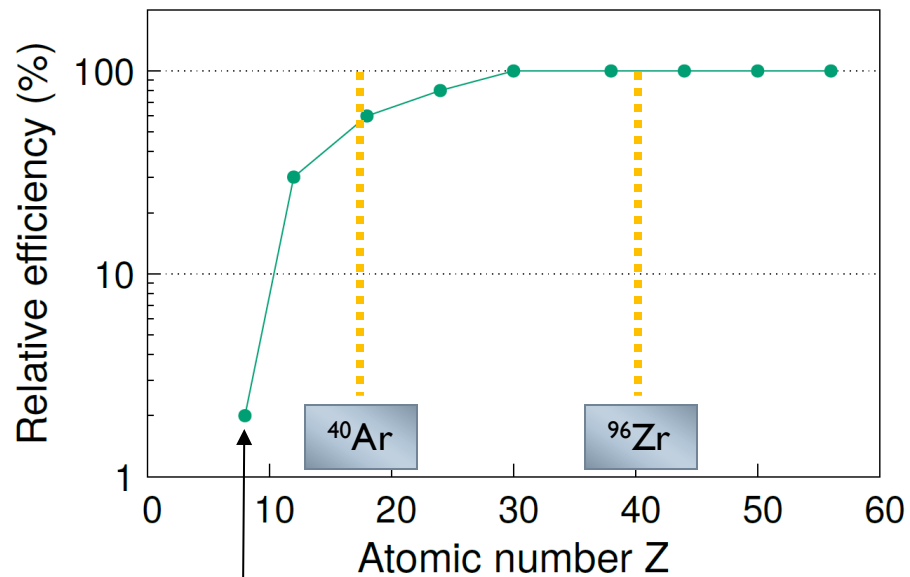

Due to the attenuation of the low anode signals by the delay lines

ToF efficiency: ions for which the ToF is > 0 / number of ions in a given Z gate.
Position efficiency: ions with an assigned mass number / number of ions in a given Z gate

With the actual MWPPAC you may find low efficiency for some sections, so "strange" structures in the focal plane position spectrum

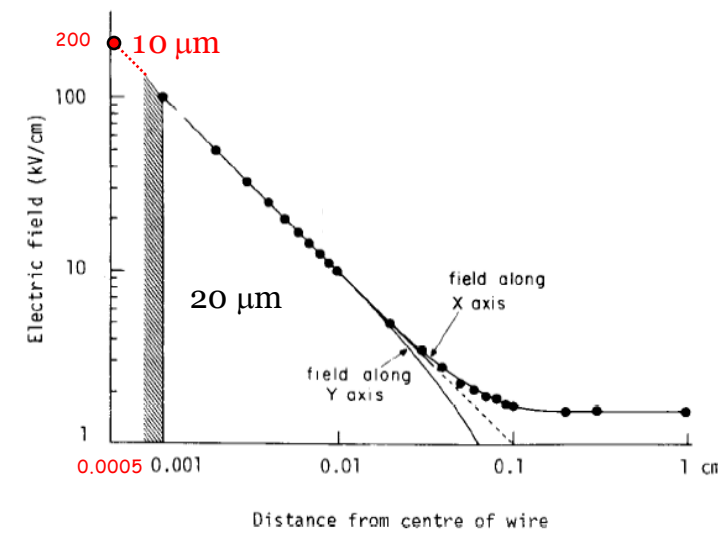
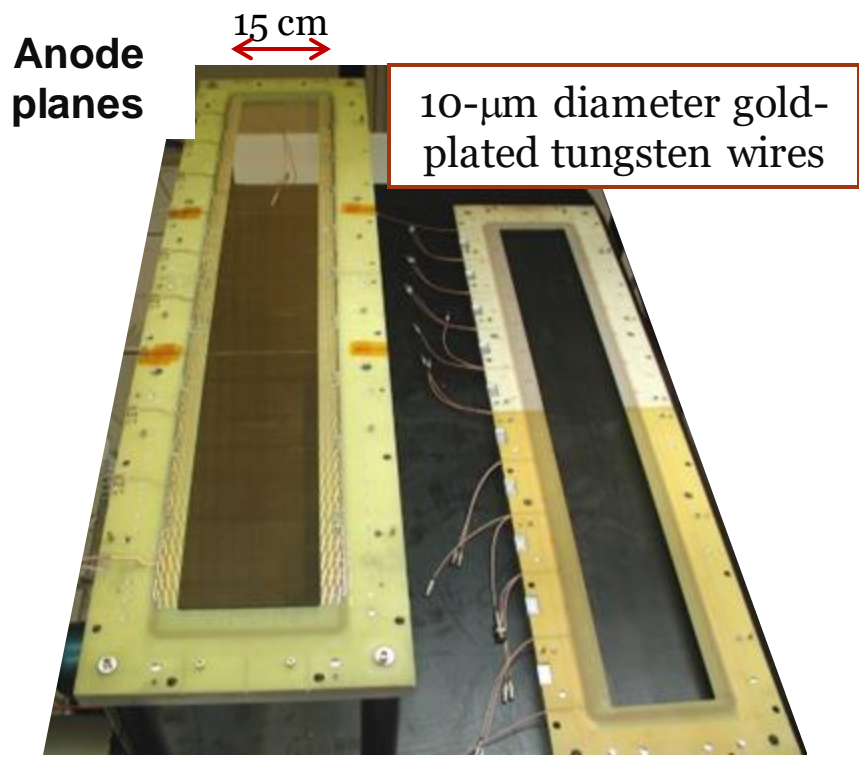

Detector efficiency improved from few % to about 40% for ¹⁶O @ 50 MeV

X_{fp} position spectra

$^{197}\text{Au}+^{130}\text{Te}$ @ 1070 MeV

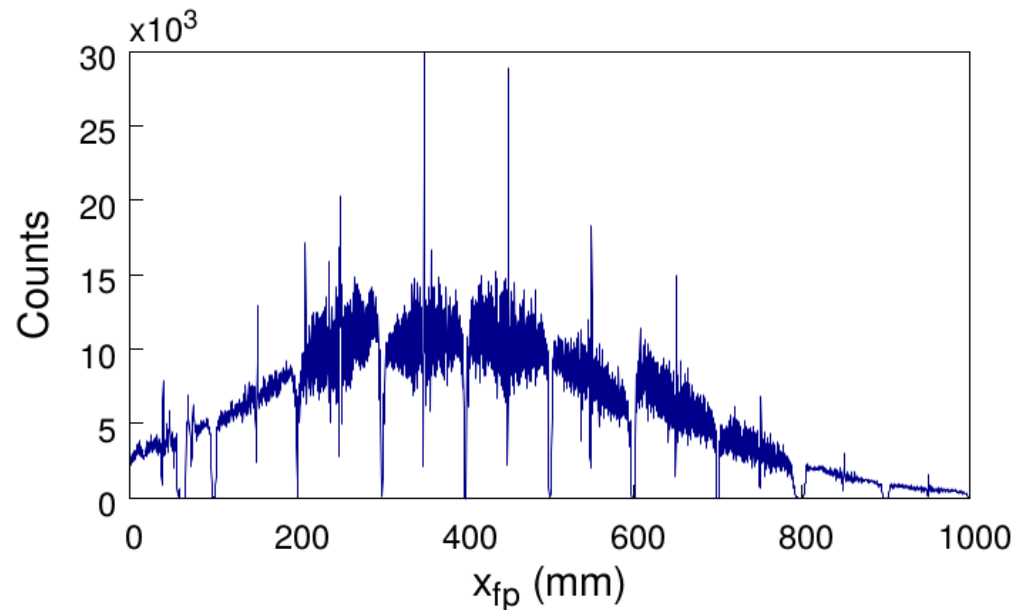

$^{32}\text{S}+^{124}\text{Sn}$ @ 160 MeV

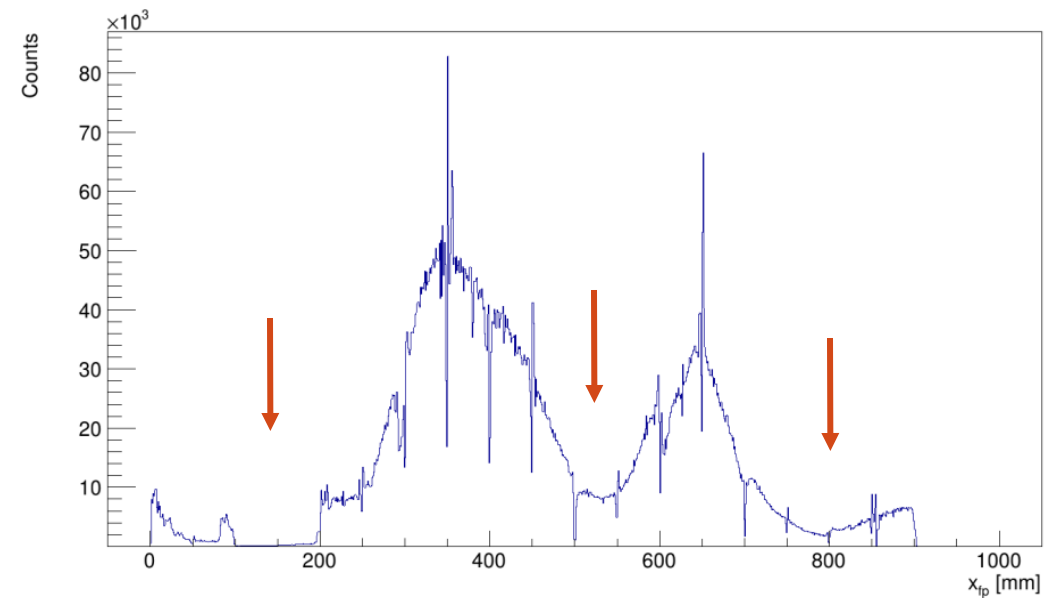

Not always clear whether it is the effect of the spacing of the different charge states (only 2-3 charge states on the fp for light ions) or an inefficiency of the section

LoI's for PRISMA (1st AGATA pre-PAC)

- 27 LoI's plan to use PRISMA
- 21 neutron-rich, 5 neutron-deficient
- 18 direct kinematics, 9 inverse kinematics

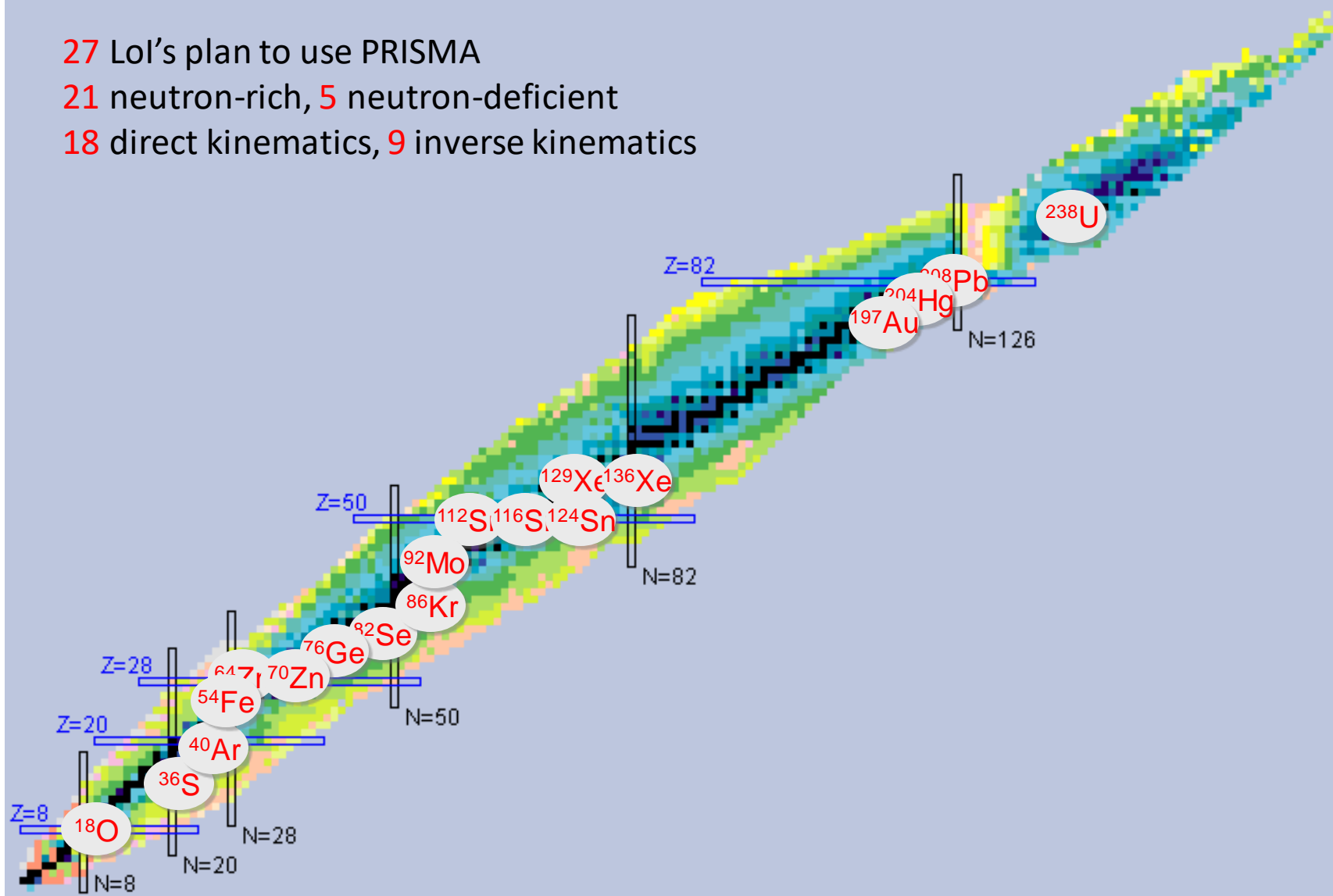

And now some insights
into the analysis with Elia