



AKADEMIA GÓRNICZO-HUTNICZA  
IM. STANISŁAWA STASZICA W KRAKOWIE

AGH UNIVERSITY OF SCIENCE  
AND TECHNOLOGY

# Reconstruction techniques and physics case for displaced tracks and vertices at LHC

Agnieszka Obłąkowska-Mucha  
on behalf of LHCb Collaboration

# Motivation and outline

1. New Physics @ LHC experiments
2. LHCb Upgrade 1:
  - SM particles
  - real-time trigger
  - novel algorithms in HLT1
3. ATLAS new trigger
4. CMS displaced muons and jets

New Physics searches take displaced vertices as the first criterium of selection

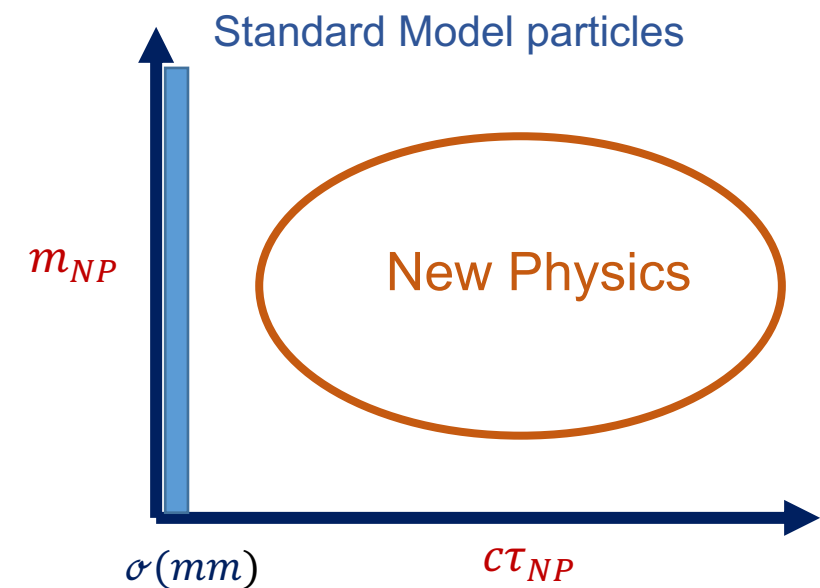
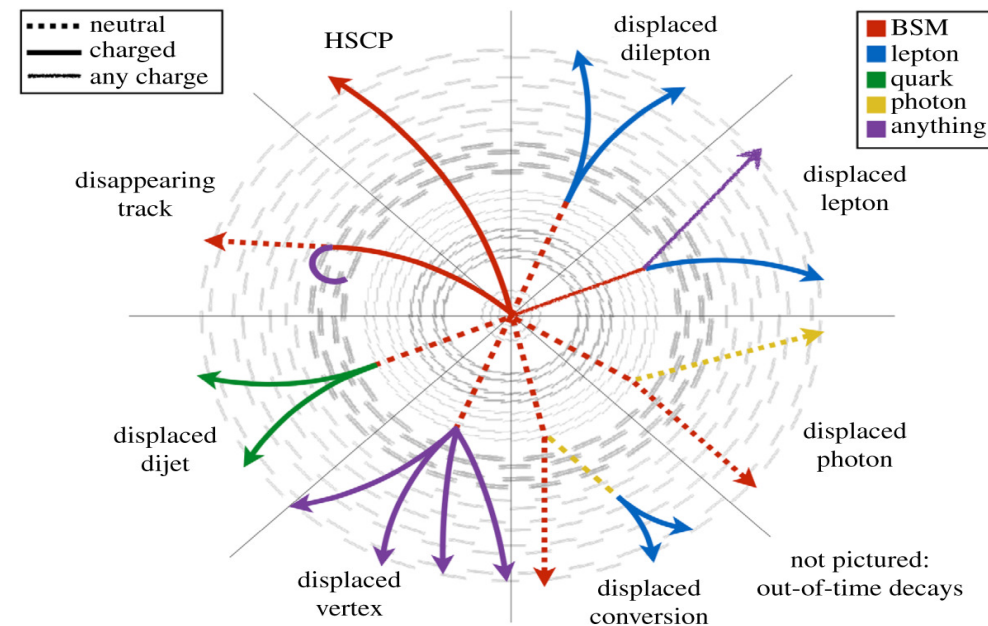

# LHC experiments

ALICE

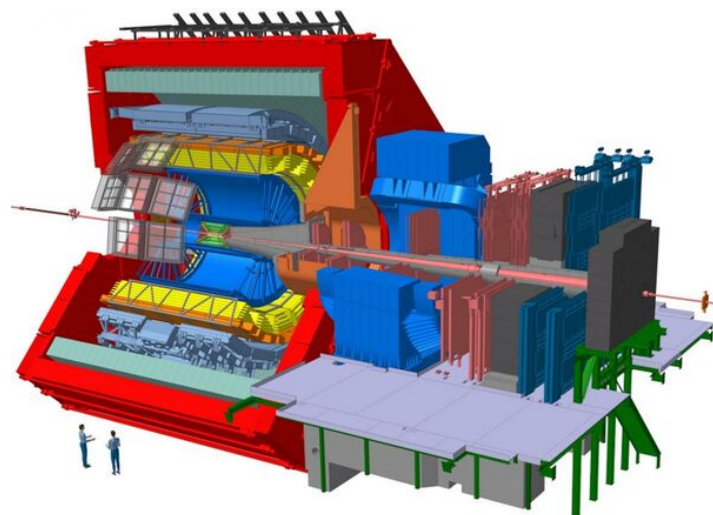

ATLAS

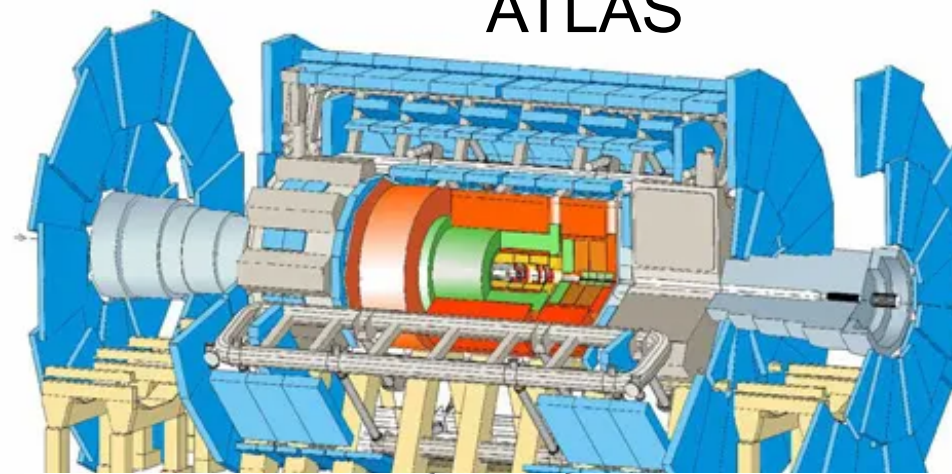

LHCb

CMS

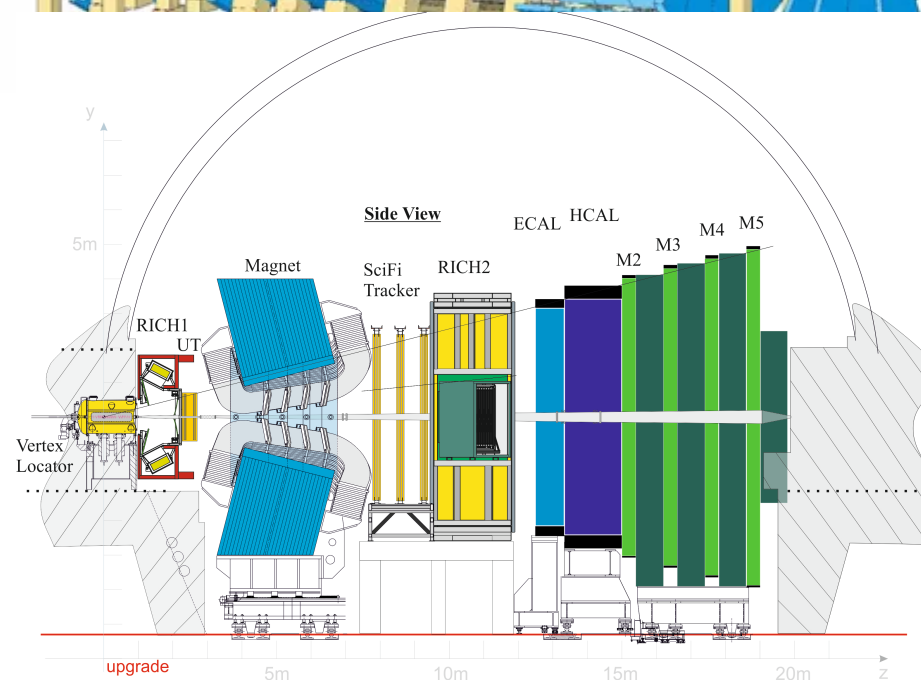
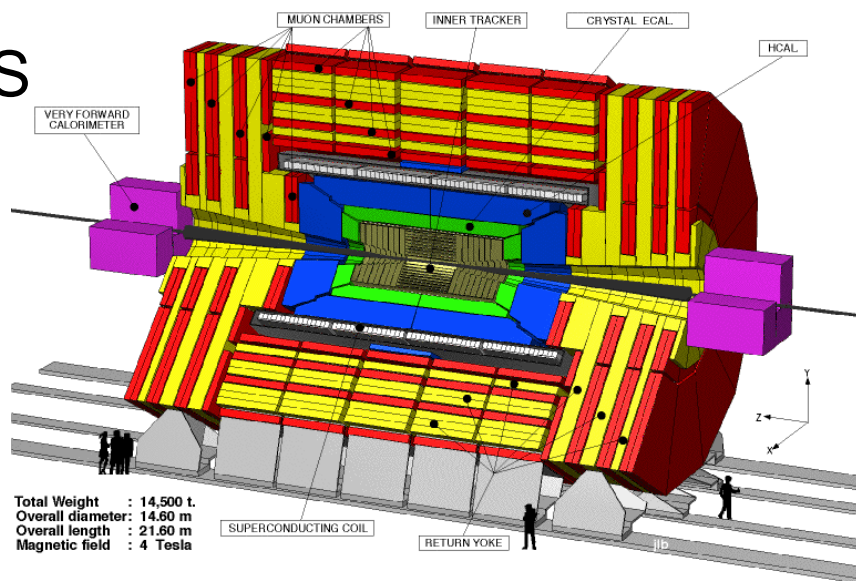

# LHCb vs ATLAS/CMS

- LHCb collects less data than ATLAS/CMS (factor  $\sim 10$ ) and has a limited acceptance.

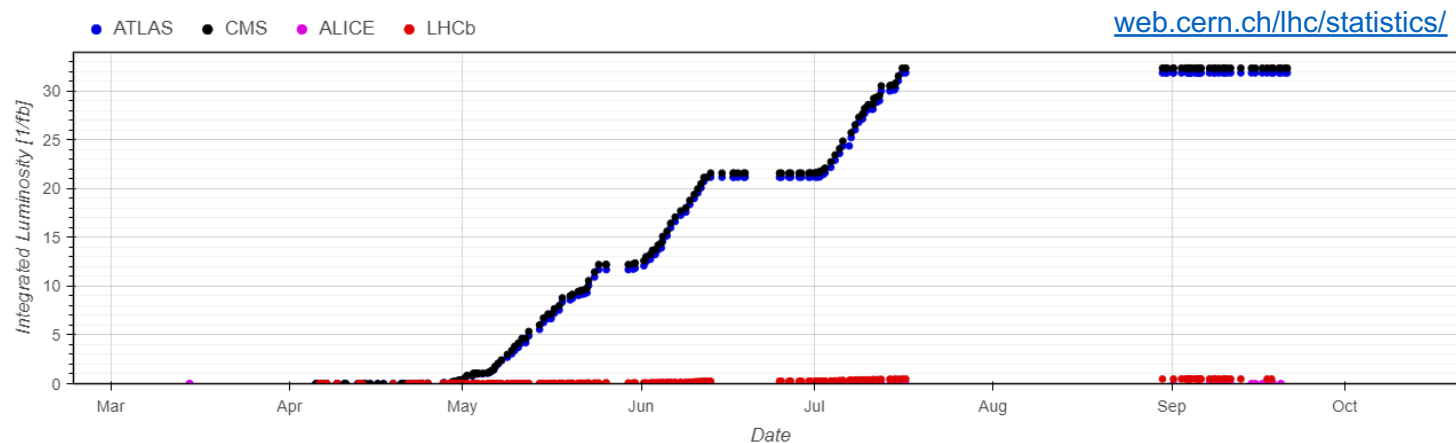

[Generated at: 2023-10-02 16:16:56]

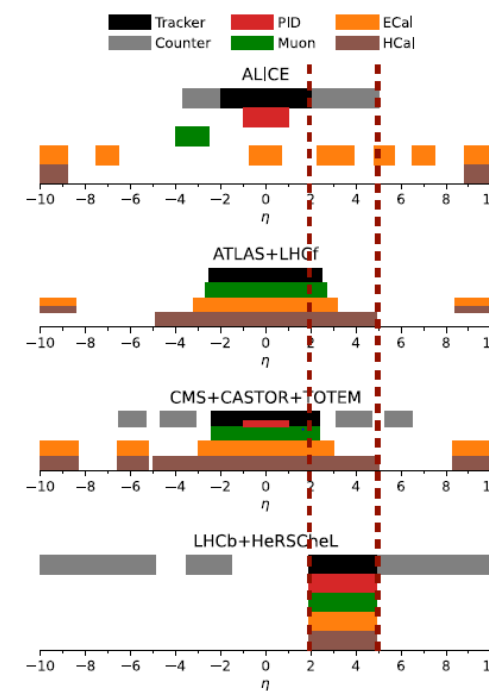

- LHCb has softer triggers (low  $p_T$ ), good vertexing, PID, momentum resolution.
- In LHCb we look into complementary phase space regions.

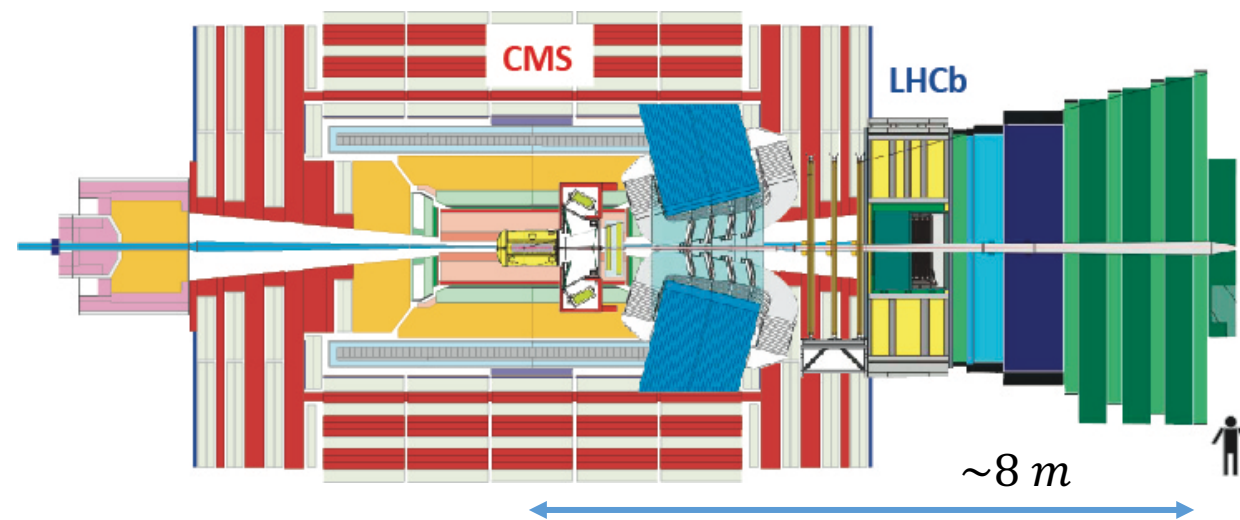

# LHCb case study: heavy flavour decays

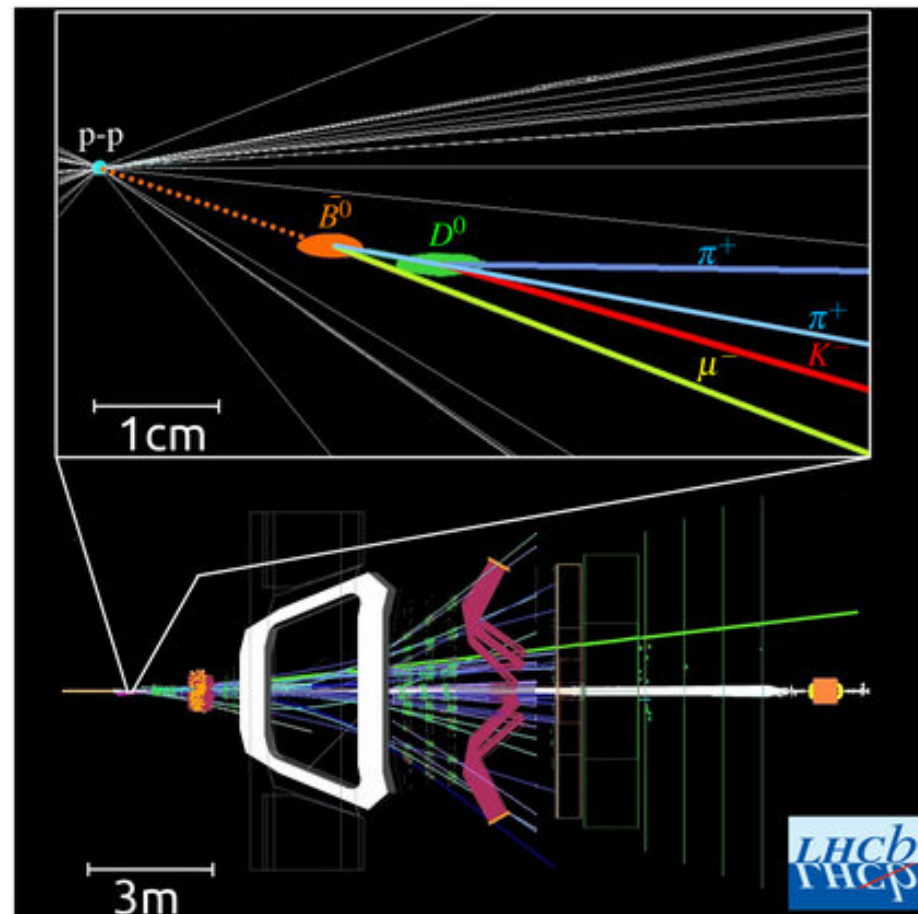

# Long-lived particles in LHCb

## Secondary vertices

Standard Model:

- Strange hadrons.
- Searches for exotic resonances in B/D decays.

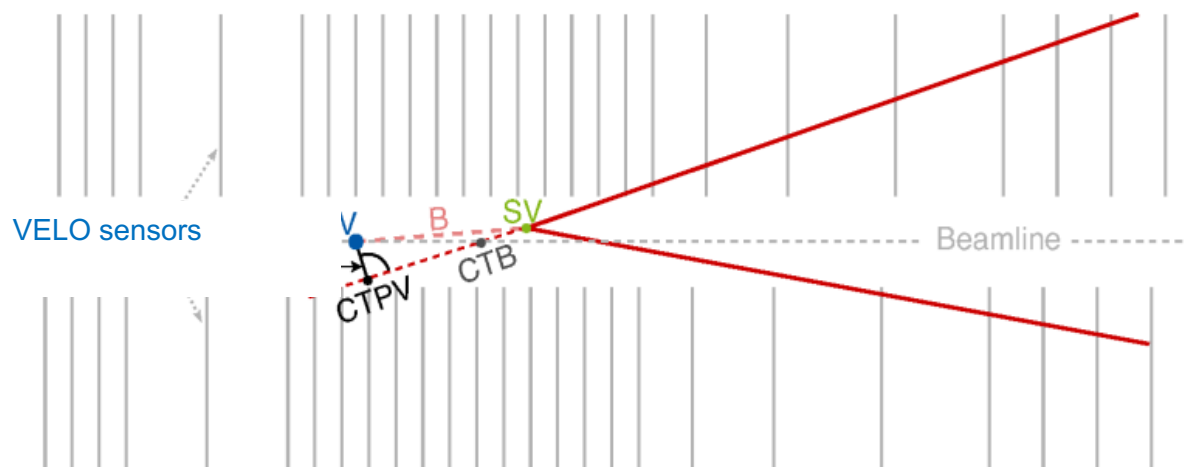

- Decays reconstructed in VELO sensors.
- Decays outside VELO

## Displaced vertices

Beyond Standard Model:

- Direct production of new particles
- Dark Matter with LL Higgs coupling,
- Dark Photon, etc

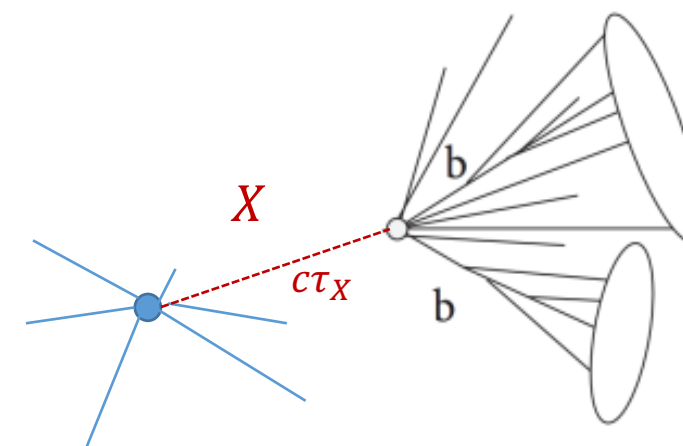

# Heavy flavours – secondary vertices

- Standard Model beauty and charm hadrons fly mm-cm distances decay into low-momentum particles.
- Tracking system (VELO, UT, SciFi) reconstructs tracks geometric and provides momentum.
- Main track types for physics analysis:
  - Long (VELO+SciFi+UT),
  - Downstream (SciFi+UT),
  - T tracks (SciFi).
- Identification system gives the mass and energy of final states so the decay tree is reconstructed.

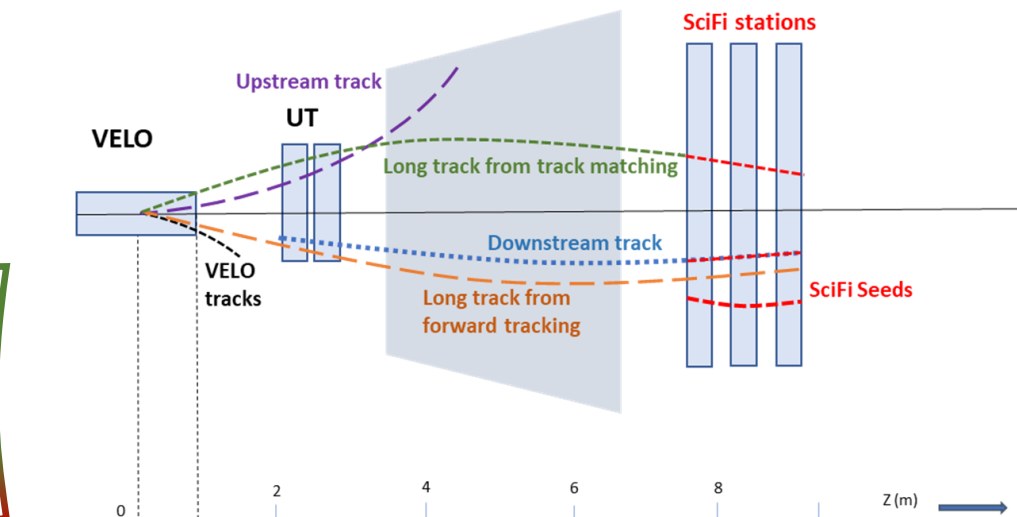
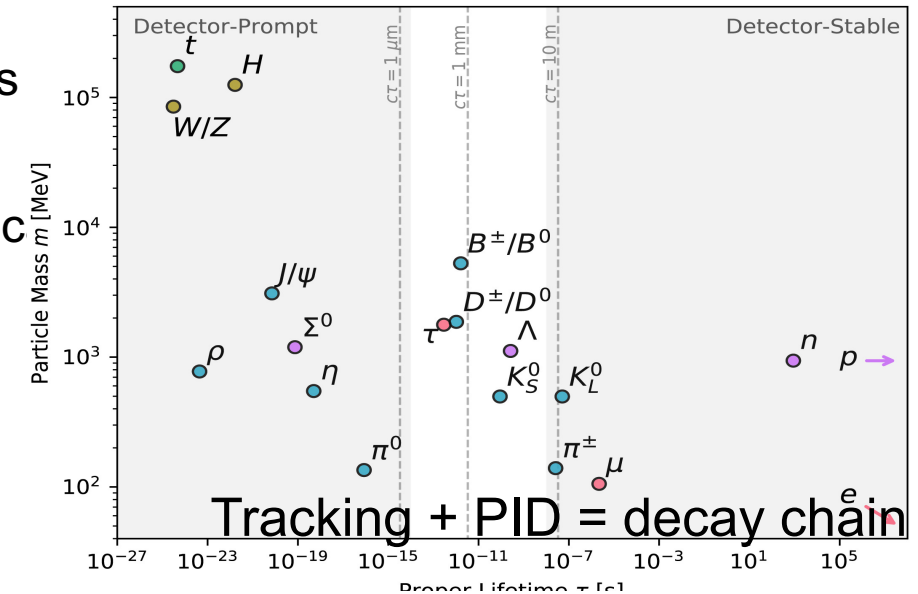

LLP  
Displacement from primary vertex – first selection  
(trigger)

# Real-Time Analysis Trigger

LHCb data are read out at 30 MHz (trigger-less system).

- **Full software trigger:** GPU based HLT1 and HLT2 reduce data rate to **10 GB/s** with the offline quality.
- HLT1 data are used for calibration and alignment.
  - Data for physics analysis follows the criteria of trigger lines based on several parameters (partially reconstructed event in real time).

HLT1TwoTracks, HLT1FourTracks, etc. tracks are required to be displaced with respect to the PV

- NN implemented in inclusive heavy flavour selection!
- **May 2022** – first real-time selection in LHCb on stable beams
- HLT2 provides full event reconstruction (including PID) with  $\mathcal{O}(300)$  selection lines over every event.

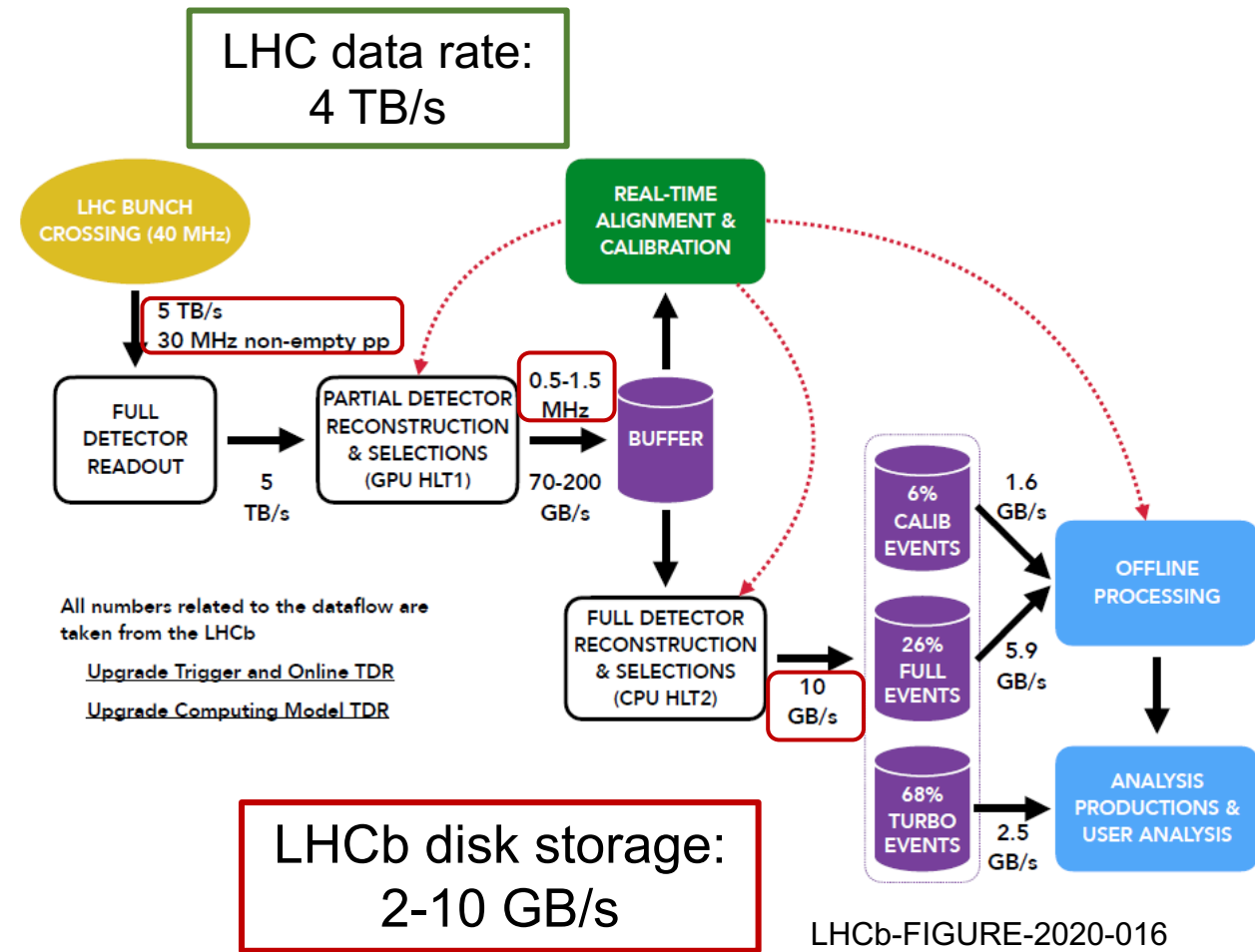



# Long-lived SM particles in LHCb Run 3

- Strange hadrons reconstruction in Run 3:
  - first LLP early triggering – HLT1 selections: **TwoTrackKs, TwoKs**
- Simulation studies:
  - selection optimised with TMVA (criteria as in Run 2, typical for secondary vertices) – general-purpose TwoTrackMVA selection,
  - negligible impact on HLT1 timing- ~%GPU, keeps 30 MHz read-out.
- Small **Run 3 2022 data** sample shows  $K_S^0$  with good purity of collected candidates.

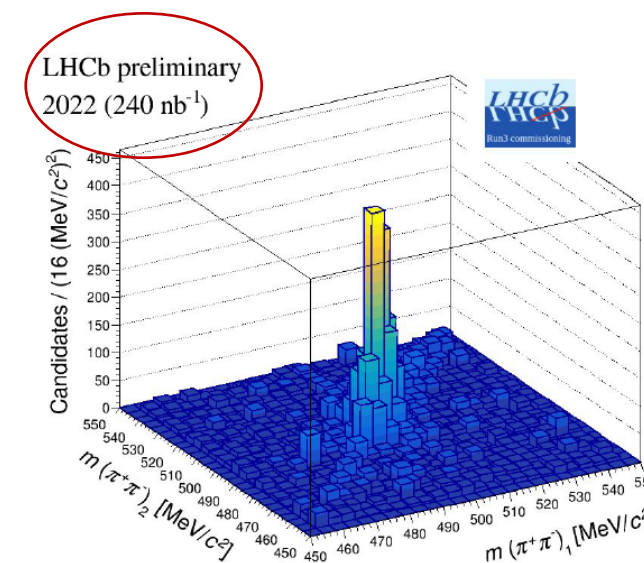
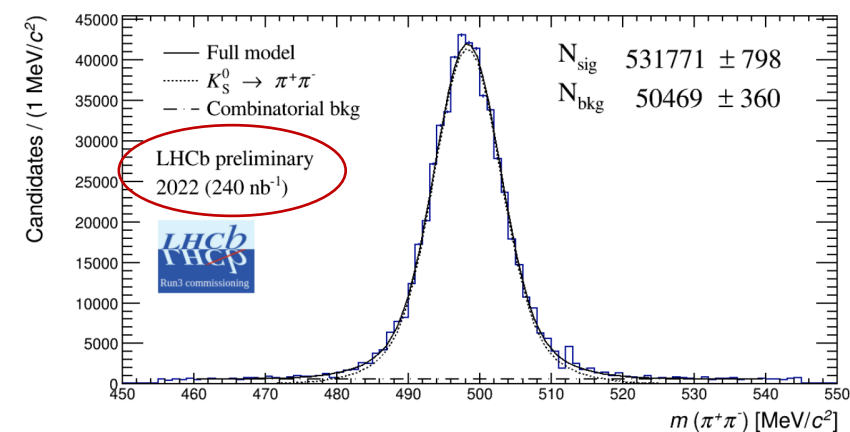

# Long-lived SM particles in LHCb Run 3

## Decays outside VELO

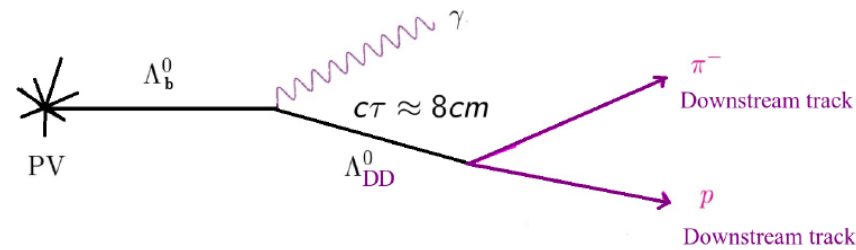

- Ongoing LHCb effort toward HLT1 Downstream triggering ([10.3389/fdata.2022.1008737](https://lhcb.org/fdata.2022.1008737))
  - extremely computationally expensive (see the next slides).
  - Long and Downstream Tracks were used for physics analysis for max decay length  $\sim 2\text{m}$ .

## Displaced vertices

- FPGA-based device for so-called Downstream Tracker (from Run 4) [1525 \(2020\) 012101 \(ACAT 2019\)](https://arxiv.org/abs/1525)
  - solve heavy pattern recognition right after readout

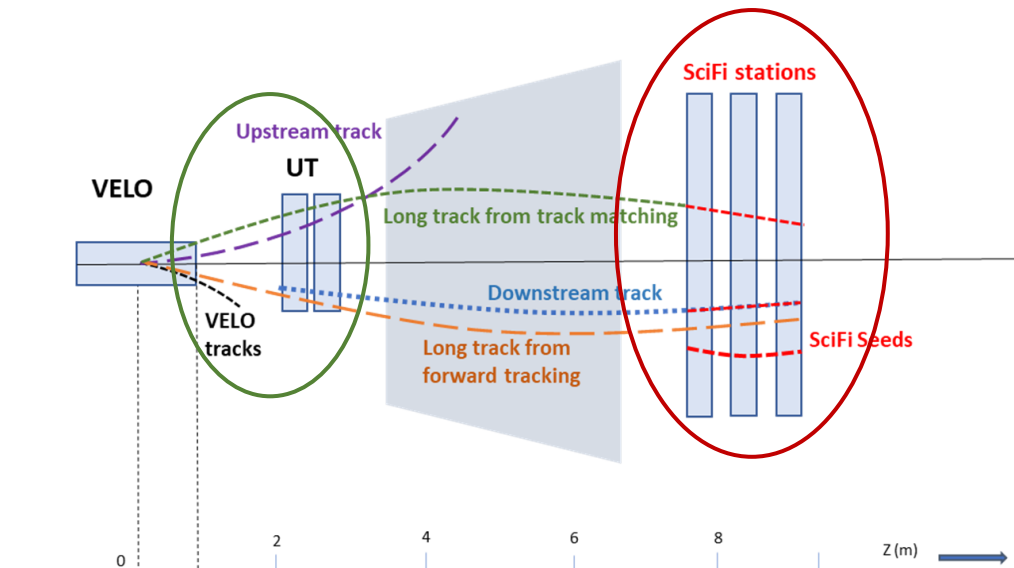

# High Level Trigger in LHCb Upgrade

- Long living particles (LLPs) are likely to decay after VELO (Downstream or T tracks).
- Current **HLT1** triggers long tracks only – less sensitive to LLPs searches.
- Let's implement the **Hybrid seeding** and add LLP reconstruction to HLT1: [arxiv:2007.02591](https://arxiv.org/abs/2007.02591)

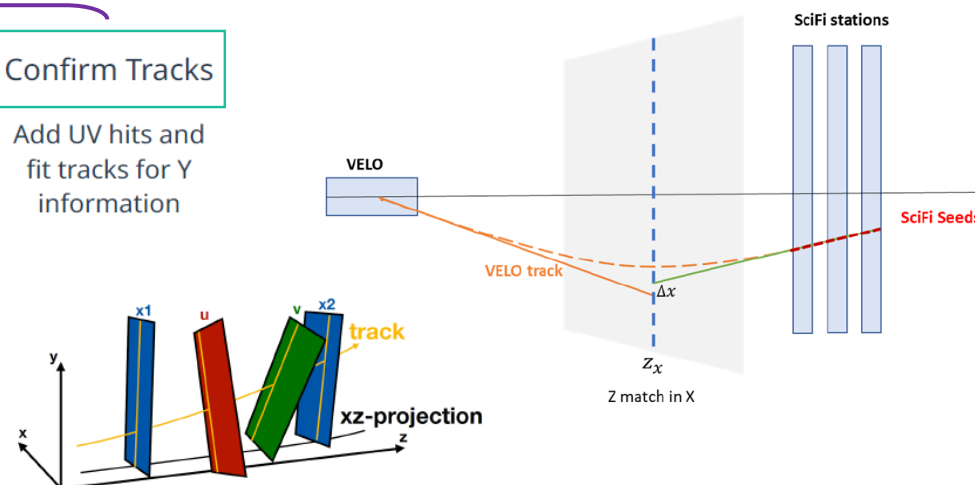
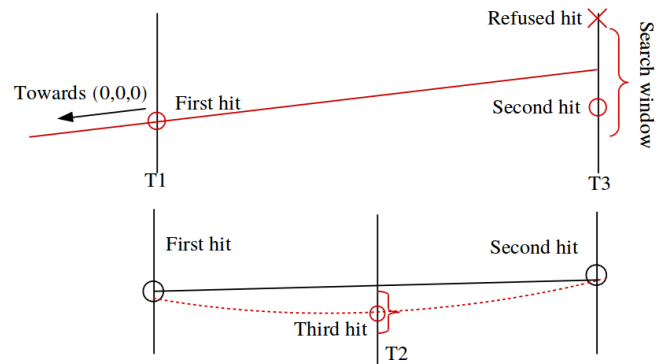
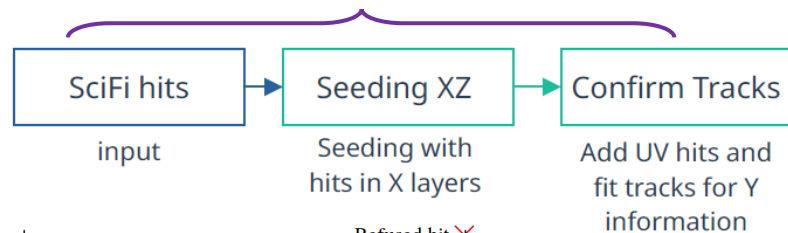
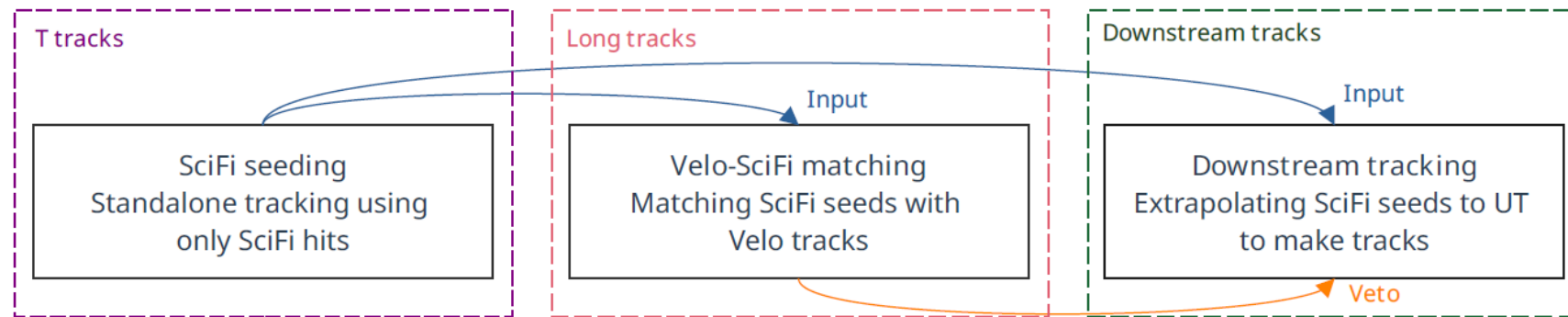

# High Level Trigger in LHCb Upgrade

- Long living particles (LLPs) are likely to decay after VELO (Downstream or T tracks).
- Current **HLT1** triggers long tracks only – less sensitive to LLPs searches.
- Let's implement the Hybrid seeding and add LLP reconstruction to HLT1: [arxiv:2007.02591](https://arxiv.org/abs/2007.02591)

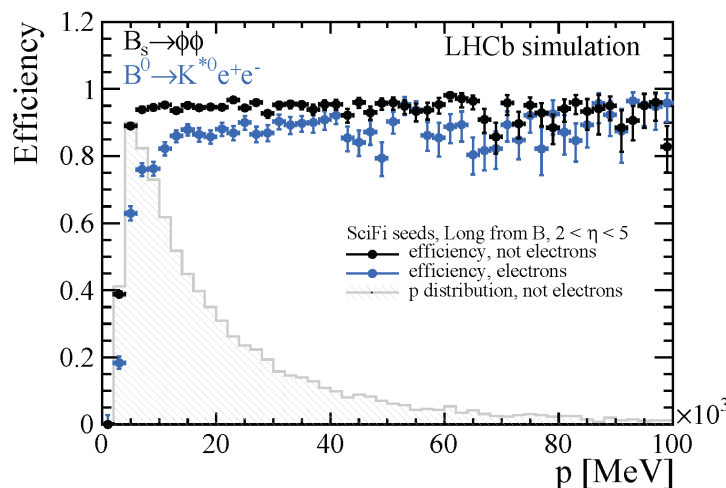
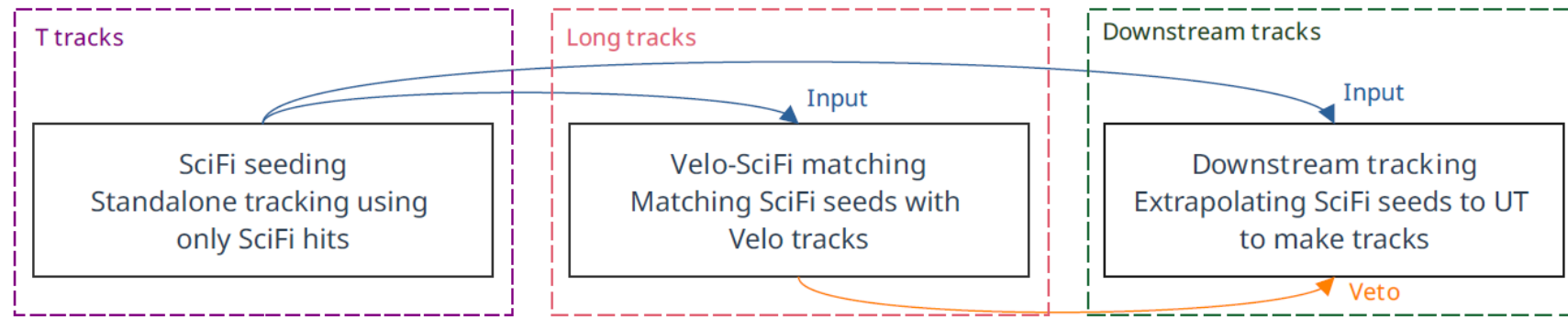

LHCb-FIGURE-2022-010

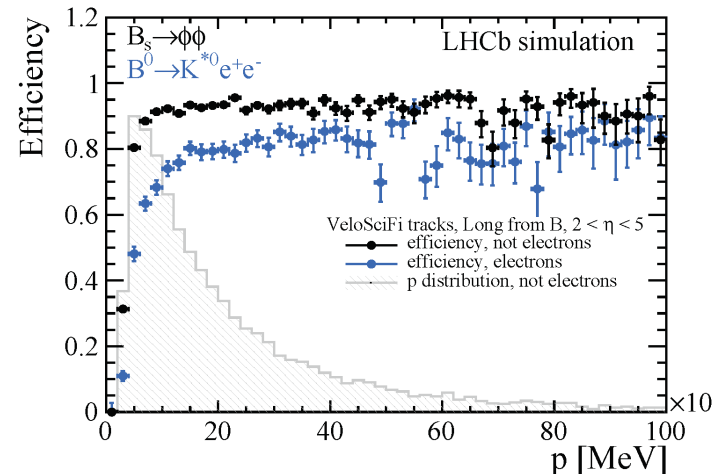

A.Oblakowska-Mucha

UT hits to be added after the commissioning

Now:  
SciFi seeds in HLT1 (GPU) which are basic building blocks for downstream tracking.



## RUN 2:

- A plethora of LLPs searches based on dedicated track and vertex reconstruction.
- Limited efficiencies due to:
  - large flight distances, escaping from the most precise detectors,
  - displaced tracks and vertices,
  - low transverse momentum.

## RUN 3:

Dedicated trigger is necessarily

### Disappearing Track Trigger:

- categorise tracks based on number of Pixel and SCT hits (tracklets)
- Train BDT on various track-related quantities to remove fake tracks,
- lower missing momentum threshold and increase in acceptance.

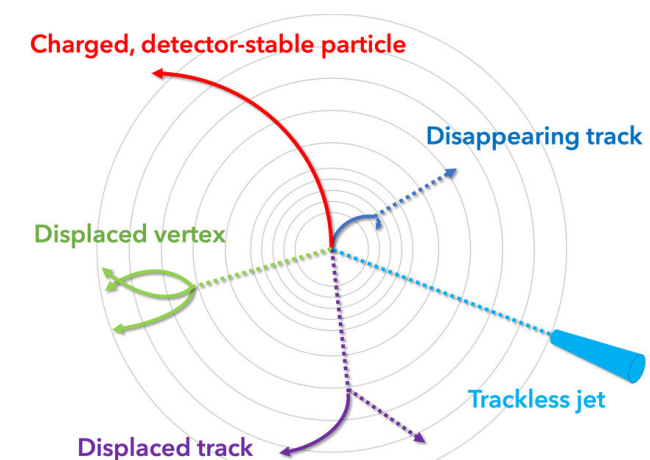
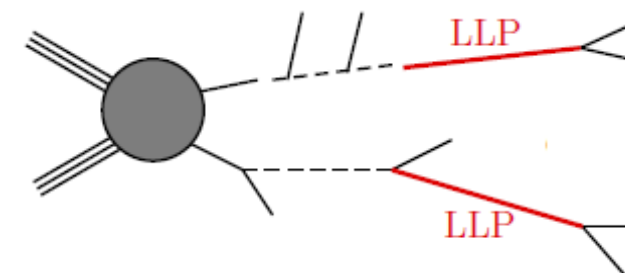

2019 JINST 14 P11099

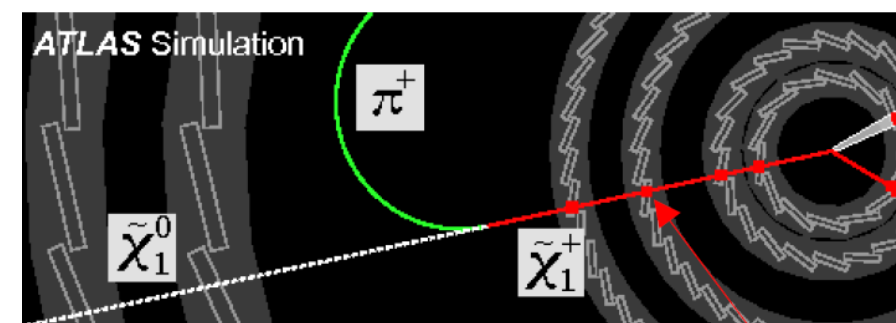

# ATLAS LLP tracking (displaced leptons)

LLPs decays should occur in ID

- **Large Radius Tracking** (Run 2):
  - modification of standard ATLAS reconstruction (increased distances from IP)

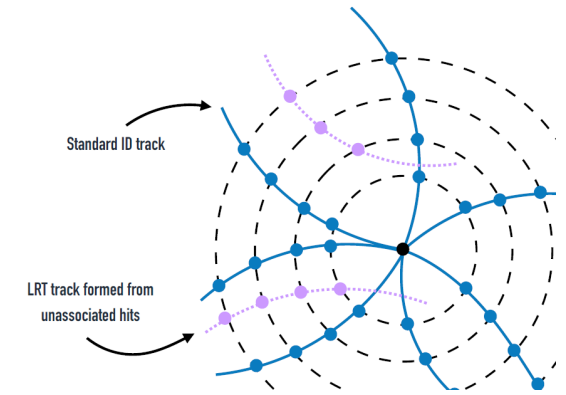

J.Burzynski CTD Workshop 2022

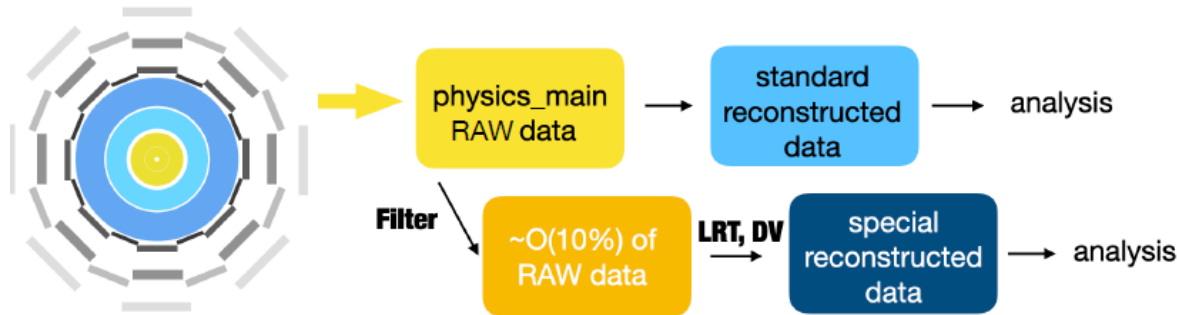

- In Run 3 reoptimised for fake reduction and CPU time.
- Trigger runs LRT like offline tracking and standard reconstruction over entire detector,
- Displaced electrons and muons up to 30 cm.

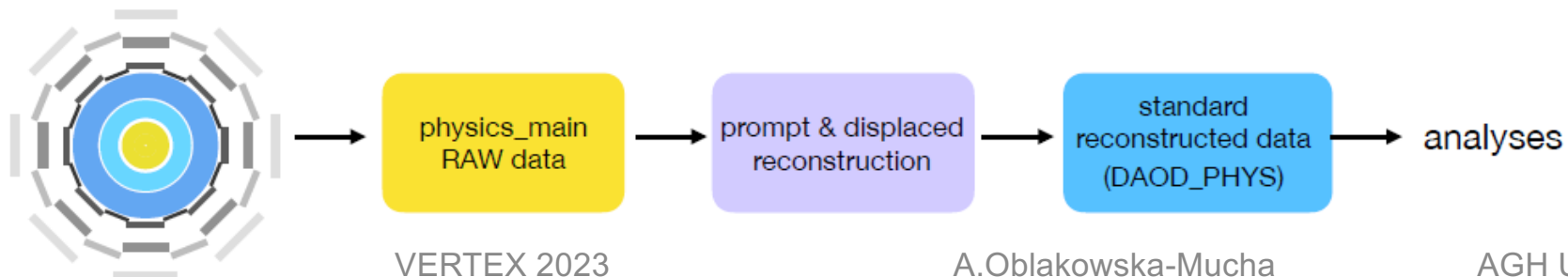
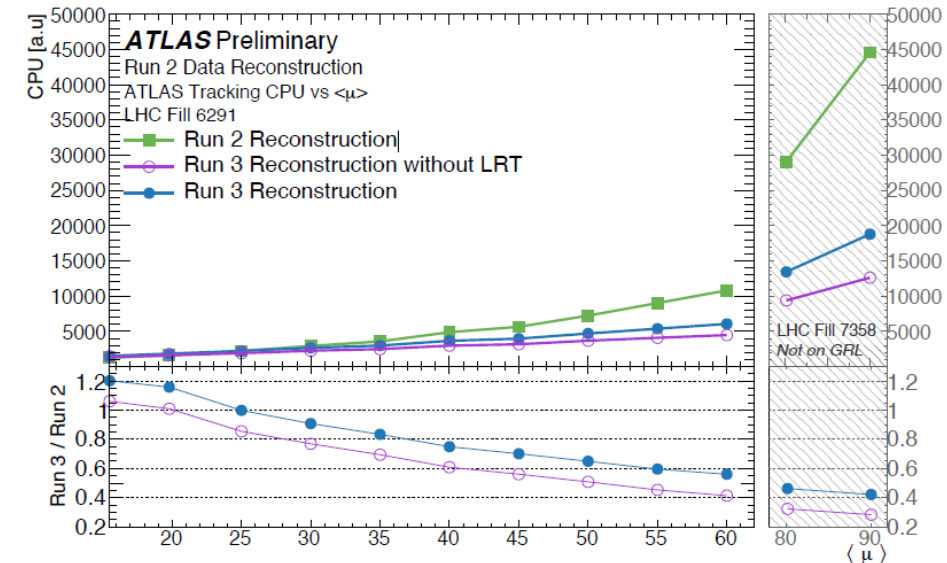

# Performance of Large Radius Tracker

Efficiency with simulated samples:

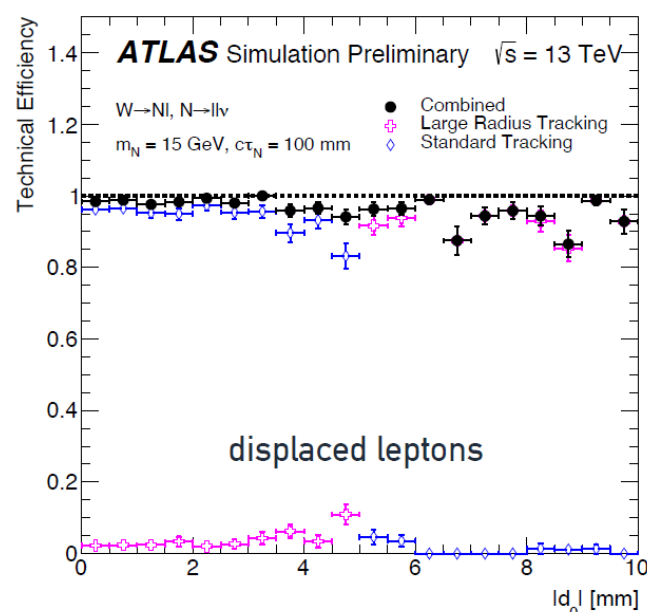
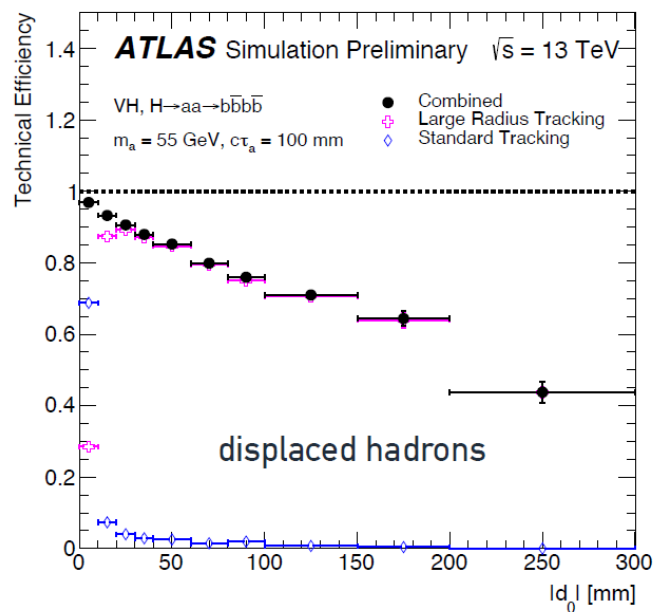

Neutral kaons vertices for  
 $472 < m_{vtx} < 522$  MeV  
 2-track, standard and LRT tracking

Data!

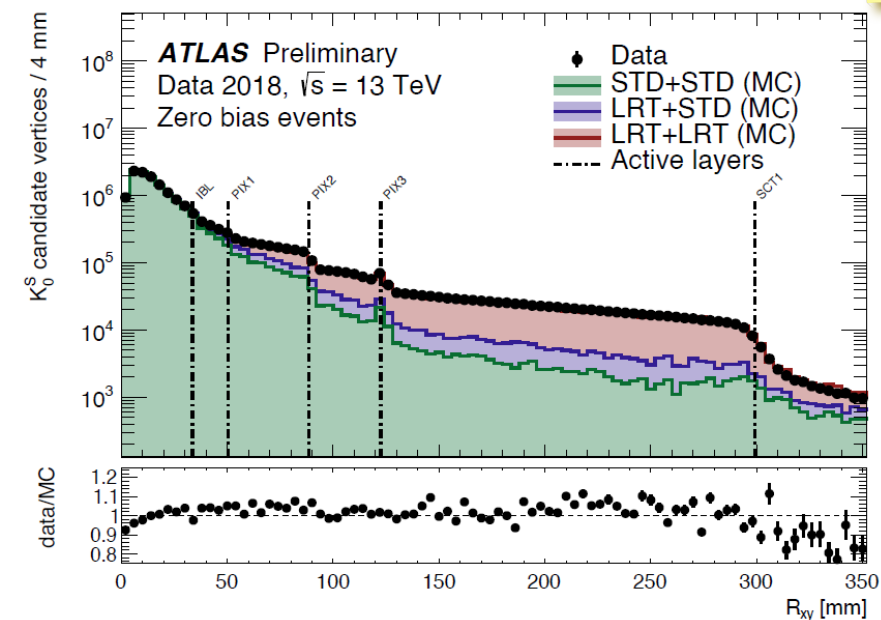

HL-LHC, new Inner Tracker: ML applied to tracking (Graph Neural Network)

# CMS Trigger in Run 3

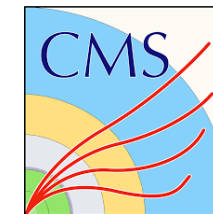

- Run 3 trigger: new tracking in HLT based on optimised pixel track.
- Software based trigger online trigger running on CPU+GPU farm.
- GPU reconstruction implemented and fully commissioned
  - calorimeter and pixel local reconstruction + pixel tracking + vertex reconstruction
  - The execution time per event of was reduced by ~40%

[CMS DP2023-024](#)

## Displaced muons:

- Muons originating from a common secondary vertex separated from pp interaction by distance  $\sim \mu\text{m}$  to several meters (dimuon trigger)  
[Phys. Rev. Lett. 127\(2021\) 261804](#)
- Search for LLP with high missing energy in 4 endcap muon detectors (7-10.5 m away from IP).

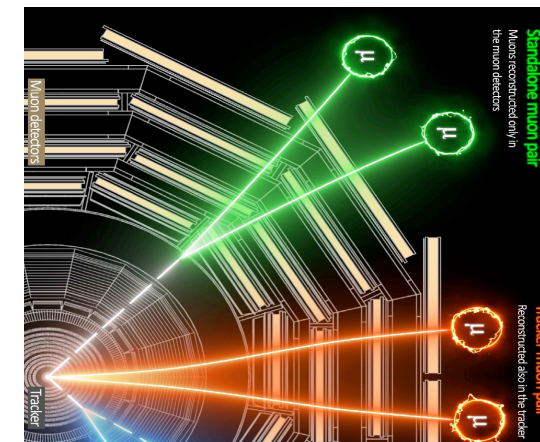

CMS Experiment at LHC, CERN  
Data recorded: Mon Nov 1 01:20:45 2021 CET  
Run/Event: 346509 / 28321286  
Lumi section: 30

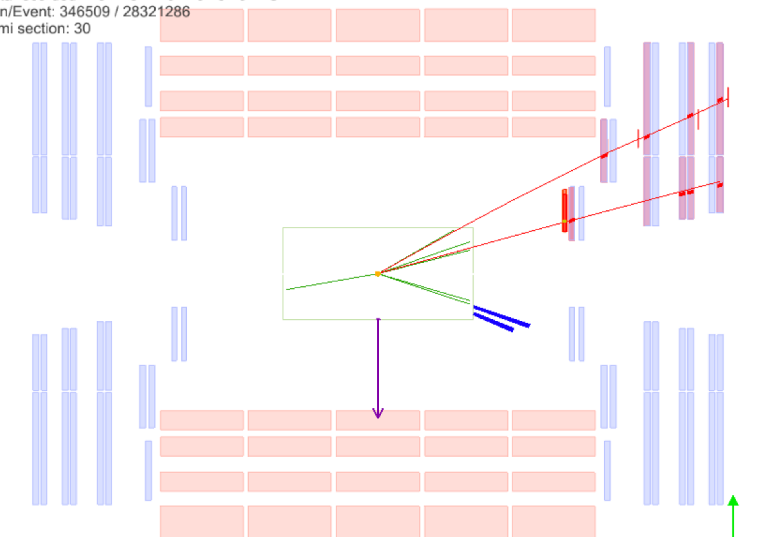

CMS-PHO-EVENTS-2021-031



# Displaced jets: CMS

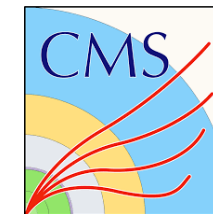

- Goal: model-independent search for displaced jets.
- LLP should decay inside the tracker, decay vertex displaced from production vertex no more than 55 cm in transverse plane.
- New dedicated trigger tested in Run 2 and applied in Run 3.
- Identification of PVs.
- Jets reconstructed by energy deposits in calorimeter, with tracks associated with PV and missing momentum.

Displaced trigger  
more efficient for low-mass LLP

Inclusive trigger  
high-mass LLP with decay length  
<3 mm or >300 mm

- Full event reconstruction offline with BDT to estimate background etc.
- Reconstruction of secondary vertex.

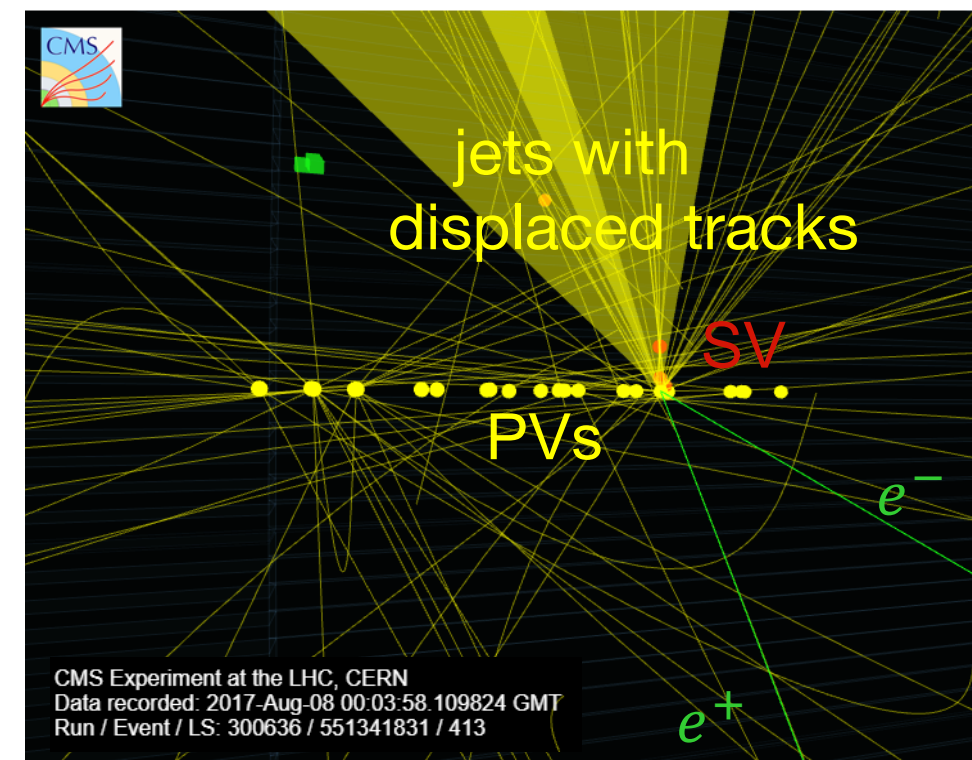

<https://cms3d.web.cern.ch/EXO-20-003/>

# Summary

1. Progress in LLP reconstruction was done mainly due to better reconstruction algorithms, run on GPU and usage of ML techniques.
2. LHCb:
  - software trigger on CPU+GPU successfully selects secondary vertices,
  - hybrid seeding implemented for displaced tracks,
  - Run 4 and beyond, FPGA-based trigger: pattern recognition for tracking with RETINA algorithm,
3. ATLAS: Improved efficiency in L1 trigger and HLT with new Large Radius Trigger
4. CMS: new tracking with fully implemented GPU reconstruction and displaced muon and jets searches.
5. ALICE: new detector readout, continuous for ion events.



2024 data taking