

Mega-Cell PDE measurement at CIEMAT

C. Palomares on behalf of the CIEMAT group

April 21 2023

CIEMAT SETUP



New vessel
300 L → 500 L

CIEMAT SETUP



CIEMAT SETUP

The Mega-cell efficiency will be measured in LAr using a ^{241}Am α -source

- 500 L cryogenic vessel with different concentric volumes (designed and order in autumn 2022)
- Two concentric internal volumes:
 - A cylinder of 500 L filled with LN2
 - A parallelepiped of 80L (*cassette*) filled with GAr (99.9999%) (Mega-cell)
- GAr liquefied with LN2 controlling the pressure.

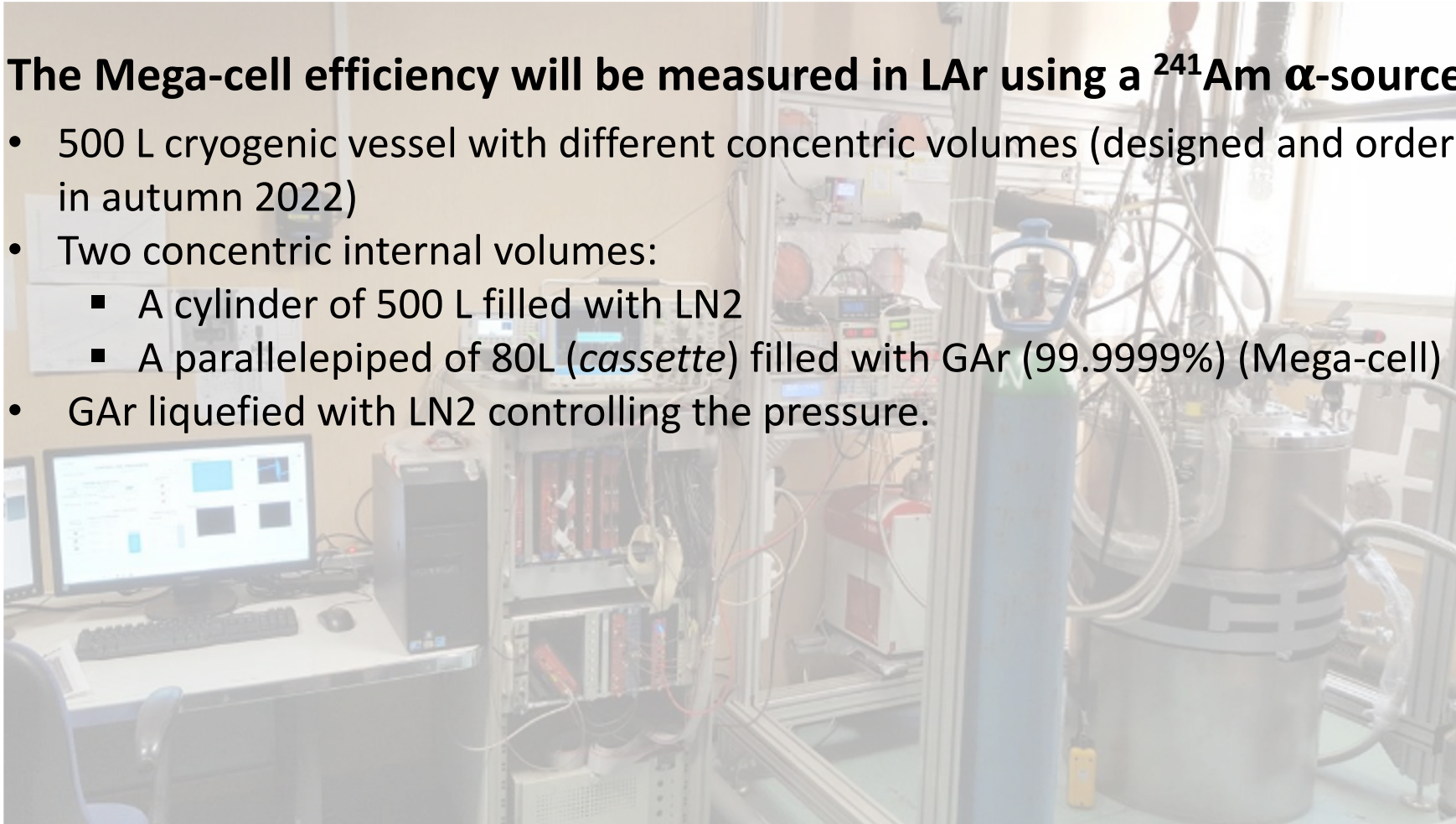

New vessel

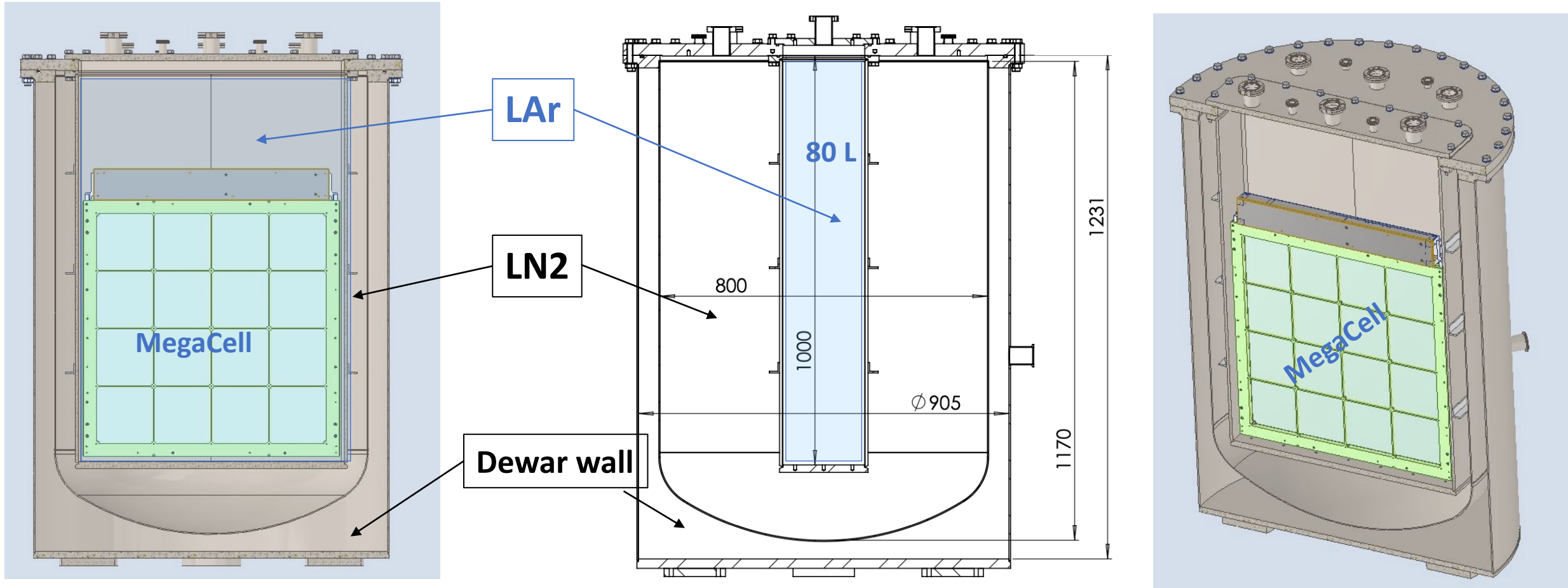

Methodology

- The alpha particle deposits its energy inside a black box facing a M-C filter (the rest of the M-C is covered with a black sheet)
- PDE measurement in 3 positions: corner, lateral, central
 - 3 runs of measurements with box in different positions
 - Use of 3 boxes equipped with a guillotine (only 1 is open)
- The sensors will be calibrated with an optical fibre attached to the box, using LED and Lasers of different wavelengths.

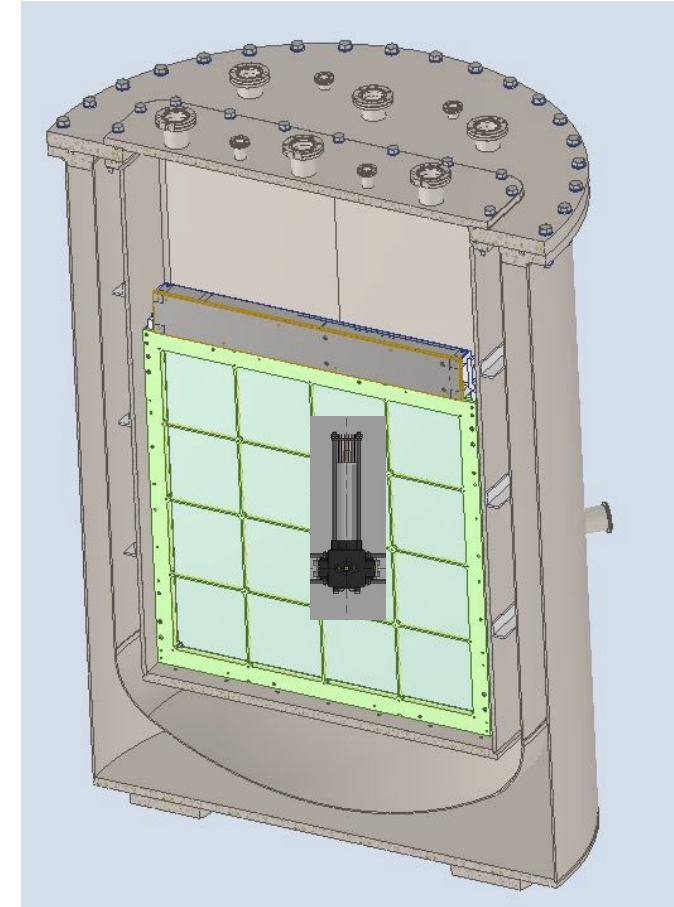

Setup

Calibrated VUV sensitive SiPMs will be used as reference

The black box holding the α -source and the sensors is being improved

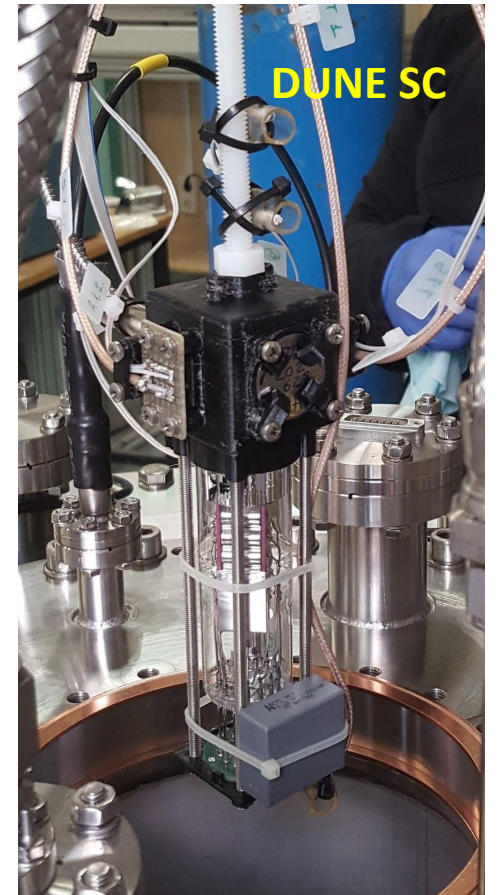
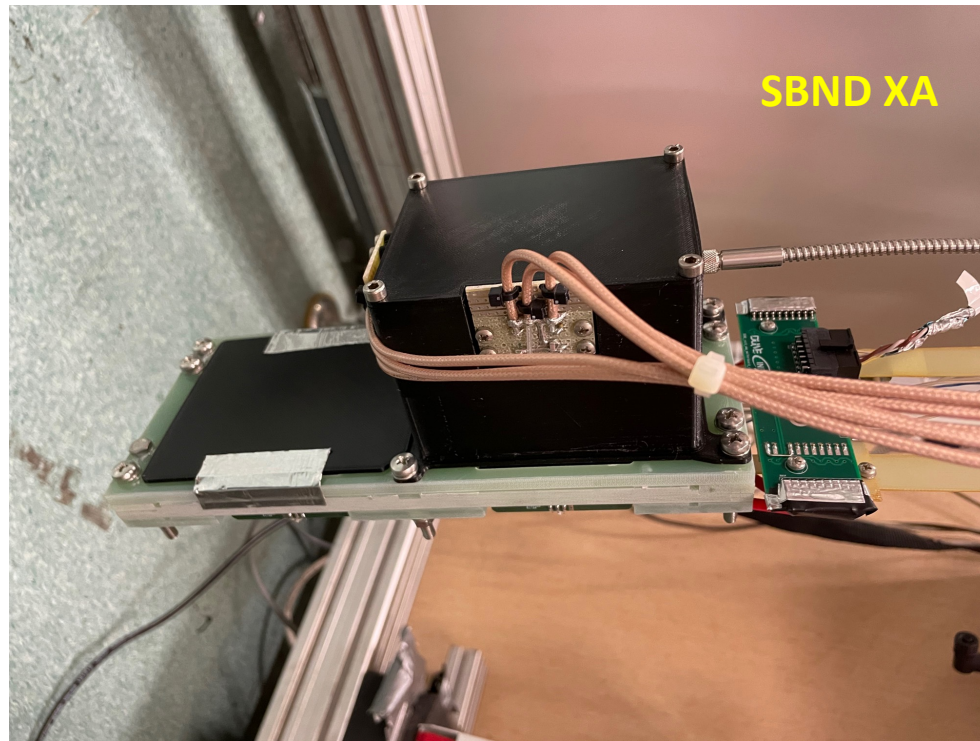

Setup

New box design used in XA-SBND tests

- A complete filter is exposed to the α -source inside the box
- 4 VUV SiPM's (to reduce systematic errors)

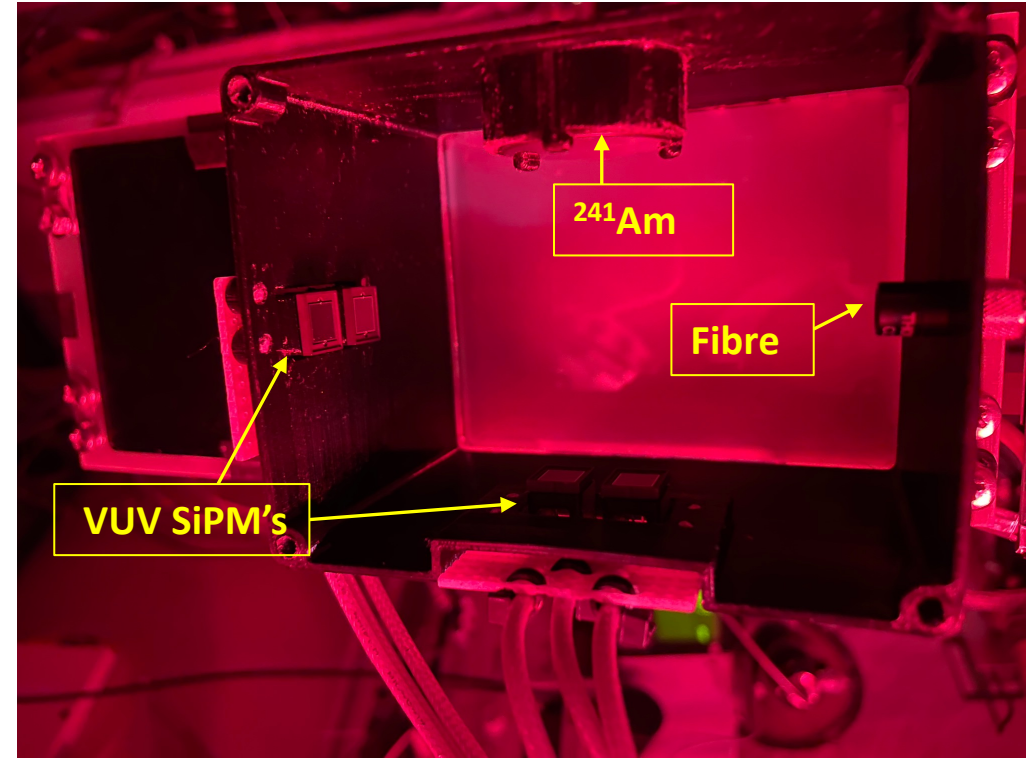
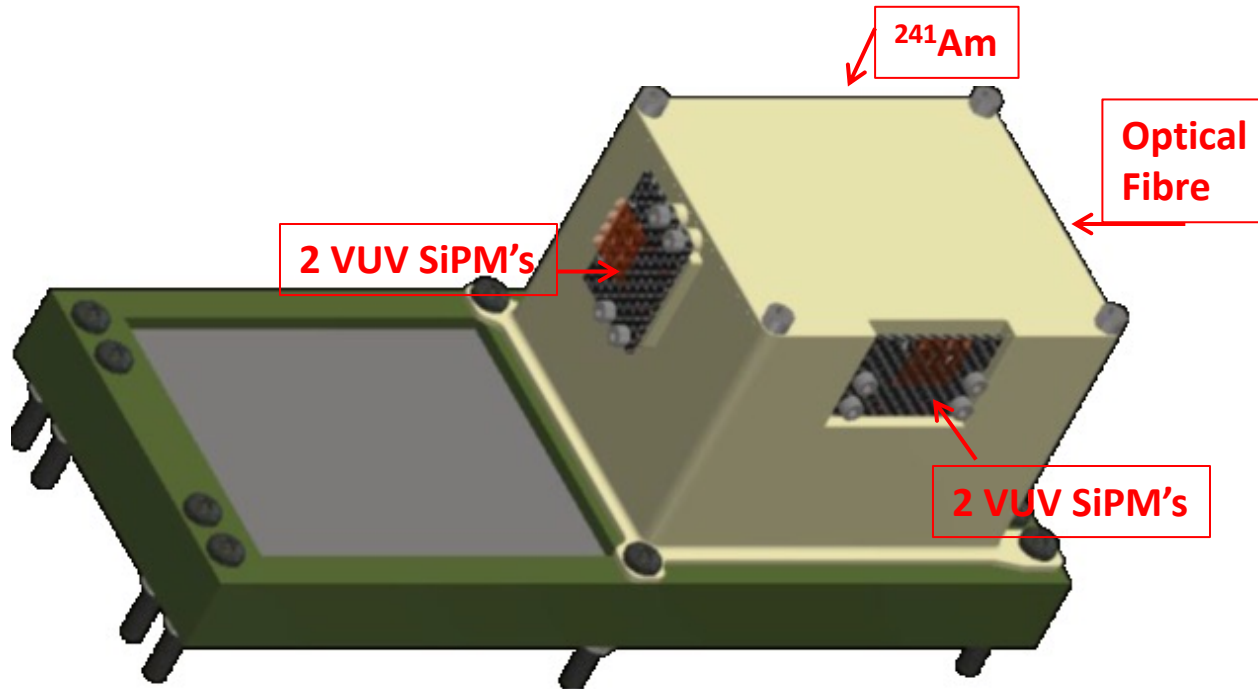

Schedule

- New Vessels ready by **mid-May**. Pressure tests for certification on-going
- The first tests of liquefaction **beginning of June**
- Dichroic filters are manufactured. Two sets of 18 ZAOT filters coated. A third one will be sent to Campinas before end April (ZAOT received Yesterday the CIEMAT purchase order).
- Mechanics: we have received a very expensive offer (~9000 € / set). Searching for other companies
- SiPM's will be provided by INFN
- WLS bar will be provided by Milano-Bicocca