

Internship report

“3D CAD Modeling and Mechanical Integration at the Mu2e
Experiment at Fermilab”

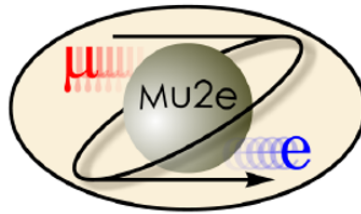

Marco Commisso

Internship carried out from 29/07/2023 to 30/09/2023

Internship tutors : Mr. George Ginther

Referent teacher : Prof. Simone Donati

Educational institution : University of Pisa

Internship host company : FERMILAB - Fermi National Laboratory

Abstract

This abstract encapsulates a transformative summer internship at Fermilab, focusing on the Mu2e Experiment within the Mechanical Integration and 3D CAD Modeling group. The internship was characterized by a two-phase approach, with the initial month dedicated to the design of an aluminum platform tailored for DS Trench Maintenance. This phase encompassed a comprehensive exploration of structural integrity, material selection, and precision engineering principles, demonstrating an adeptness in CAD modeling and a keen eye for detail.

The subsequent month saw a seamless transition into a dynamic phase of the project, wherein the intern played a pivotal role in effecting numerous adjustments across diverse sections of the 3D experiment structure. This phase demanded a nuanced understanding of the intricacies of the Mu2e Experiment and a high level of proficiency in CAD modeling.

Key words: Mechanical Design, NX Software, Mechanical Integration, 3D CAD Modeling

Contents

1	Introduction	1
1.1	Mu2e Experiment: physical prospects	1
1.2	Mu2e Experiment : mechanical parts and technological challenges	4
2	Work environment	6
2.1	NX Software	6
2.1.1	Principal features	7
2.2	Mu2e Experiment in NX: Main Assemblies	8
3	First Task: design and modeling of an aluminum platform	10
3.1	Objective of the structure	10
3.2	Design and Building the structure	12
3.3	Structural Simulations	14
3.4	Placement Constraints	17
3.5	Weight analysis and Optimization	20
4	Second Task: Cleaning the 3D model	23
4.1	Detector Train Assembly	24
4.2	DS Trench and Cables Assembly	27
4.3	Shielding Assemblies	30
5	Conclusion and perspectives	34

abundant in the Universe, unlike their stable counterpart, the electron, continues to challenge scientific understanding. The Mu2e experiment sets the ambitious goal of shedding light on this mysterious discrepancy, through the direct observation of muon-to-electron conversions, an extremely rare phenomenon not predicted by the **standard model**. To carry out this extraordinary experiment, it was necessary to develop cutting-edge technologies capable of capturing and studying extremely rare and fleeting events. From the acceleration and collimation of muon beams to their interaction with the target nucleus (aluminum target), every phase of the experiment requires unprecedented precision and sensitivity. The use of state-of-the-art detectors, capable of discriminating between background events and signals of interest, is a crucial piece in the success of Mu2e. Beyond the purely experimental aspect, the Mu2e experiment fits into a broader context involving fundamental questions in cosmology and the deep structure of the Universe. Understanding the interactions between elementary particles at such extremely subtle levels is destined to illuminate the early moments of the Universe and shed new light on theories regarding its formation and development.

Here's a step-by-step explanation of what happens during the entire process:

Muon Creation: The experiment starts by generating a beam of muons, typically by bombarding a target material (tungsten) with high-energy protons (8 GeV). These protons create a cascade of secondary particles, including muons, through a process known as **pion decay**. Muons are unstable particles and will eventually decay into other particles, but **the conversion process is extremely rare**.

The most probable event for muons is the process of normal decay, which is elucidated in the subsequent paragraph.

Muon Decay: Muons have a finite lifetime, and their natural decay process involves the transformation of a muon into an electron, accompanied by the emission of two neutrinos. The weak force, which governs these interactions, is responsible for this transformation.

Muon Decay Equation: $\mu^- \rightarrow e^- + \bar{\nu}_e + \nu_\mu$

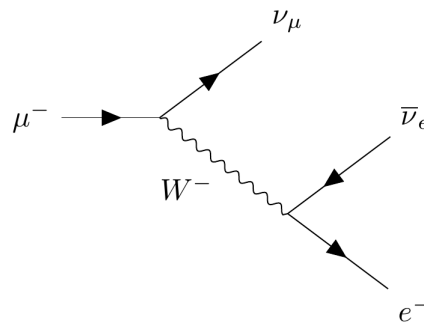

Fig. 2: Most common muon decay

In this equation, μ^- represents a negatively charged muon, e^- is an electron, $\bar{\nu}_e$ is an anti-electron neutrino, and ν_μ is a muon neutrino. On the other hand, what the Mu2E experiment aims to validate is the following process.

Muon Capture: researchers attempt to capture and study muons before they decay

naturally. This is done by employing a combination of magnetic fields and other focusing elements to guide and slow down the muon beam, increasing the chances of capturing a muon before it decays. The capture will be done in the stopping target of the experiment made of Aluminum nuclei.

Conversion Observation: If a muon is successfully captured, scientists closely monitor it for any signs of a transformation into an electron. **This is a rare event, and it's precisely what the Mu2e experiment is designed to observe.**

Detection of Electron: If a muon does undergo conversion, it transforms into an electron. This electron is then detected using sophisticated particle detectors that can measure its energy, position, and momentum. These measurements provide critical information for confirming the occurrence of muon-to-electron conversion.

It's important to note that the muon-to-electron conversion process is highly suppressed within the framework of the Standard Model of particle physics. Therefore, observing this phenomenon requires incredibly sensitive detectors and carefully designed experimental conditions. The Mu2e experiment at Fermilab is at the forefront of this research, aiming to detect and study muon-to-electron conversion events with unprecedented precision. Understanding this process could provide valuable insights into the fundamental properties of muons and may lead to discoveries beyond the scope of our current understanding of particle physics. In this introduction, we have only scratched the surface of a scientific project of extraordinary scope and complexity. The Mu2e experiment at Fermilab represents a milestone in scientific research and promises to open doors to new dimensions of knowledge, carrying with it the promise of answers that challenge the very boundaries of our understanding of the Universe. In the upcoming chapters, we will delve into the experimental foundations of this fascinating project, discovering how scientists are laying the groundwork for a new era of scientific discoveries.

Who ordered that?
— Nobel Laureate I. Rabi's response to the discovery of the muon.

Muons interact with three forces:
 gravity
 electro-magnetism
 weak force

The Marvelous Muon

Spin: 1/2
 Charge: -1
 Generation: 2

Lifetime: ~2 millionths of a second

Mass: $105.7 \text{ MeV}/c^2$, ~200 electrons

Original names: mesotron, mu, meson

Discovered: 1936

Usual decay: electron + muon neutrino + electron antineutrino

Several HUNDRED muons pass through your head EVERY MINUTE.
(Most can't even see you, they interact with our atmosphere.)

Muons can penetrate and image objects much like X-rays can. They have been used to image the inside of pyramids — where researchers found hidden chambers.

Greek symbol: μ
 Particle class: lepton

Antimatter version: antimuon (or positive muon)

www.fnal.gov | Fermilab | U.S. DEPARTMENT OF ENERGY | Office of Science

Fig. 3: Muon properties

1.2 Mu2e Experiment : mechanical parts and technological challenges

The Mu2e experiment at Fermilab involves a complex array of mechanical components, each meticulously designed and precisely engineered to fulfill its specific role in the experiment's operation. These components collectively form a sophisticated apparatus that enables the study of muon-to-electron conversions.

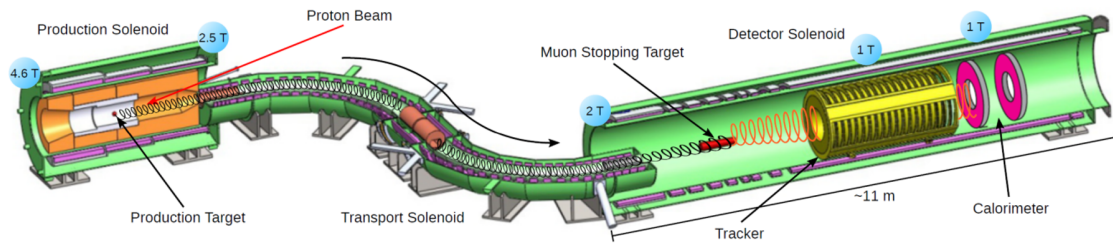

Fig. 4: Mu2e experimental apparatus

Here, we will explore some of the key mechanical elements involved:

Muon Production Target: at the heart of the Mu2e experiment lies the muon production target. This specialized component is tasked with generating muons by subjecting it to a high-intensity proton beam. The target material and its configuration are crucial in producing an optimal yield of muons.

Magnetic Field Coils: the Mu2e experiment relies heavily on strong magnetic fields for guiding and measuring charged particles. This necessitates the installation of various coils and magnet systems strategically placed along the particle trajectory. These components are engineered to produce highly controlled and uniform magnetic fields, ensuring accurate particle tracking.

Detector Solenoid: the detector solenoid is a crucial element responsible for creating a precise and uniform magnetic field around the region where muon-to-electron conversions are expected to occur. It plays a vital role in the accurate measurement of particle trajectories and momenta.

Transport Solenoids: transport solenoids work in conjunction with the detector solenoid, providing an additional magnetic focusing element. These solenoids help guide and focus charged particles along their trajectory through the experiment, increasing the efficiency of muon capture.

Muon Beamline and Collimators: the muon beamline is a carefully designed system of vacuum chambers, magnetic elements, and collimators that facilitate the precise transport of muons generated in the production target. Collimators are adjustable devices used to shape and filter the beam, ensuring only muons with the desired properties proceed

Detector Supports and Mounting Structures: the various detectors used in the Mu2e experiment need to be securely supported and precisely aligned. This involves the design and construction of robust support structures capable of maintaining stable detector positions even in the presence of strong magnetic fields.

Vacuum Systems: maintaining ultra-high vacuum conditions within the experiment is essential to minimize interactions between the muons and air molecules. The vacuum systems include pumps, valves, and carefully designed chambers to achieve and maintain the necessary vacuum levels.

Electromagnetic Calorimeter (ECal) Crystal Matrix: the "ECal" is a critical component designed to measure the energy deposited by electrons from muon conversions. It consists of an array of lead tungstate crystals, each precisely positioned and coupled to photodetectors. The mechanical structure ensures the stability and alignment of the crystal matrix.

Silicon Tracker: the silicon tracker is responsible for tracking charged particles in the experiment. It comprises layers of precision-positioned silicon sensors, held in place by sturdy support structures. These components enable the accurate reconstruction of particle trajectories.

Electronics and Cabling: the Mu2e experiment incorporates a sophisticated network of electronic components, including data acquisition systems, control systems, and cabling infrastructure. These elements are carefully designed to operate reliably in the challenging electromagnetic environment of the experiment. These mechanical components, meticulously engineered and precisely calibrated, collectively form the backbone of the Mu2e experiment. Their seamless integration and operation are crucial in realizing the experiment's ambitious goals of exploring the fundamental properties of muons and shedding light on the mysteries of the Universe.

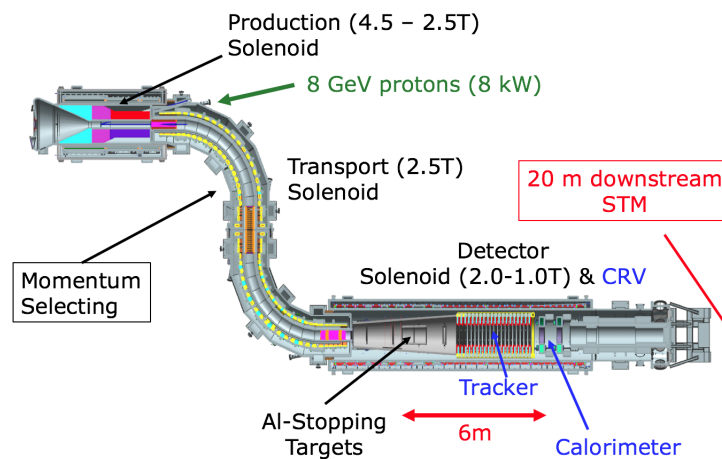

Fig. 5: Mu2e experimental apparatus (2)

2 Work environment

The progress achieved at Fermilab in my endeavors was critically reliant on the availability of a sophisticated 3D Computer-Aided Design (CAD) tool. In my specific undertaking, FNAL provided access to Siemens Digital Industries Software's NX. Each day, I securely connected to the central server using a dedicated framework named Citrix. Through this portal, I accessed the Team Center (TC) application, a central platform from which several integral tools were made accessible. Foremost among them, NX proved to be the most instrumental for my purposes. This advanced CAD software played a pivotal role in enabling the intricacies of my work to be effectively addressed.



Fig. 6: Team Center workspace and NX logo

2.1 NX Software

In the dynamic landscape of engineering design and manufacturing, the role of cutting-edge software solutions cannot be overstated. At the forefront of this technological wave stands NX, a comprehensive product lifecycle management (PLM) software developed by Siemens Digital Industries Software. NX has emerged as an industry-leading platform, revolutionizing the way engineers and designers conceptualize, create, and bring products to life. This introduction aims to provide a comprehensive overview of NX software, delving into its genesis, key features, and the transformative impact it has on engineering processes. NX, originating from the venerable roots of Unigraphics, boasts a rich history that dates back to the 1970s. Over the years, it has evolved from its early iterations into a sophisticated, all-encompassing software suite that empowers professionals across diverse industries. Its genesis lies in the vision to provide a unified platform for engineering design and manufacturing, and this vision continues to drive its evolution to this day.

2.1.1 Principal features

NX software, boasts an array of features that elevate it to the forefront of engineering and design applications. Here are some of the main features that distinguish NX.

- **Parametric Modeling:** Enables precise and flexible 3D model creation and manipulation.
- **Simulation and Analysis:** Offers tools for performance evaluation under various conditions.
- **Manufacturing Process Integration:** Streamlines transition from design to production.
- **Additive Manufacturing Optimization:** Optimizes designs for 3D printing.
- **Data Management and Collaboration:** Facilitates version control and collaborative design.
- **CAD/CAM/CAE Capabilities:** Covers the entire product development lifecycle.
- **Multi-Disciplinary Design:** Integrates various engineering disciplines.
- **Sheet Metal Design:** Specialized tools for sheet metal components.
- **Advanced Surface Modeling:** Enables complex and organic shape creation.
- **Digital Mockup and Visualization:** Allows virtual design visualization.
- **Electro-Mechanical Design:** Integrates electrical components into mechanical designs.
- **Tolerance Analysis:** Ensures proper component fit.
- **Teamcenter Integration:** Integrates with Siemens' Teamcenter PLM system.

These features collectively make NX software a versatile tool for engineering design and manufacturing across a wide range of industries and applications.

2.2 Mu2e Experiment in NX: Main Assemblies

In high-energy particle physics experiments, precision and advanced computational tools are indispensable. NX has emerged as a cornerstone in designing and simulating critical components, particularly particle detectors, magnets and in general complex components. This comprehensive software excels in parametric modeling, allowing engineers to intricately craft 3D models that ensure optimal performance of detectors.

Furthermore, NX facilitates the seamless integration of both mechanical and electronic components, enabling a holistic approach to detector development. This integration is vital as detectors often incorporate sensitive electronic systems alongside mechanical structures.

In environments where detectors are subjected to intense radiation, NX proves invaluable. Its simulation capabilities enable engineers to model the effects of radiation on materials. This empowers the selection of radiation-resistant materials and the design of shielding structures, ensuring reliable operation even in the presence of high radiation levels.

In collaborative and multidisciplinary projects, NX's data management and collaboration tools come to the fore. They facilitate smooth communication and documentation, allowing engineers and physicists to work concurrently on different facets of detector design. This ensures that all components integrate seamlessly, ultimately contributing to the success of the experiment. As high-energy particle physics experiments continue to push the boundaries of our understanding of the universe, NX software remains a crucial ally in this scientific endeavor. Its versatility, precision, and comprehensive suite of features make it an indispensable tool for designing reliable and high-performing detectors in the pursuit of scientific advancement.

How is the Mu2e Experiment structured in NX?

The Mu2e experiment is organized into one top-level assembly, which is further divided into a hierarchical structure consisting of nine macro-subassemblies:

- **Mu2E Integration Points:** These crucial junctures serve as meeting points for various components of the Mu2E apparatus, ensuring seamless integration and precise alignment. They play a pivotal role in establishing the structural integrity of the experiment.
- **Accelerator:** At the heart of the experiment lies the accelerator, a core sub-assembly responsible for providing the necessary energy to incoming protons for their collision with the tungsten target within the production solenoid. It sets the stage for the entire experiment's particle interactions.
- **Conventional Construction:** This section encompasses the standard construction elements that form the bedrock of the entire experiment. From support structures to foundational components, it lays the groundwork for the smooth functioning of the experiment.

- **Solenoids:** These specialized superconducting magnets are the workhorses of the Mu2E experiment. Their primary function is to manipulate the trajectory of muons.
- **Muon Beamline:** The beamline serves as the navigational guide for muons. It ensures that muons progress along a controlled and directed path, a crucial step in maintaining experimental accuracy.
- **Tracker:** Positioned as the vanguard of detection, the tracker assumes the role of recording the positions of charged particles. This component provides invaluable data for the analysis of muon interactions, forming the foundation for subsequent stages of data processing.
- **Calorimeter:** Tailored to the specific demands of the experiment, the calorimeter is engineered to measure the energy of particles produced in muon interactions.
- **Cosmic Ray Veto:** This sub-assembly assumes the pivotal task of distinguishing and excluding cosmic rays from the data collected during the experiment.
- **Trigger and DAQ (Data Acquisition):** At the core of data management lies the Trigger and Data Acquisition system. It governs the initiation of data collection processes in response to specific events, overseeing the efficient acquisition of experimental data.

Each of these sub-assemblies plays a distinctive and indispensable role in the larger framework of the Mu2E Experiment, contributing to the comprehensive understanding of muon-to-electron conversion phenomena. The seamless integration and harmonious operation of these components are imperative for the success of the experiment.

3 First Task: design and modeling of an aluminum platform

3.1 Objective of the structure

The initial directive encompassed the task of conceptualizing a structural framework tailored to the exigencies of the maintenance area. This framework was expressly designed to streamline access to some valves and cables, thus addressing a critical operational need. In consonance with a strategic deliberation, the decision was made to employ an alloy derived from Aluminum, more specifically, the distinguished 6XXX series. Within this series, alloy 6061-T emerged as the definitive choice for construction. This alloy undergoes a meticulous two-stage heat treatment process involving solubilization followed by artificial aging. Through this treatment, the inherent strength of aluminum is significantly augmented, concurrently bolstering its resistance to wear and tear.

Alloy type 6061 stands distinguished by its judicious amalgamation of magnesium and silicon as primary alloying constituents. The second digit within its nomenclature assumes the role of an indicator pertaining to the degree of impurity regulation applied to the foundational aluminum. In instances where this second digit assumes the value of "0", it conveys that the majority of the alloy consists of commercial-grade aluminum. This formulation inherently accommodates extant levels of impurities, thereby obviating the necessity for specialized measures to regulate impurity levels. The third and fourth digits in the nomenclature serve as unique identifiers for individual alloys. It is pertinent to underscore that this nomenclature convention deviates from that observed in the 1xxx series of aluminum alloys.

The 6061 aluminum alloy manifests a density of 2.7 grams per cubic centimeter (g/cm^3), indicative of its substantial material density. Beyond its remarkable density, this alloy exhibits the remarkable attribute of being amenable to heat treatment, thus endowing it with enhanced mechanical properties. It demonstrates an inherent malleability, rendering it conducive to facile forming operations. Furthermore, its weldability amplifies its versatility in fabrication processes. Noteworthy as well is its commendable resistance to corrosion, an invaluable trait in environments where exposure to potentially corrosive elements is a concern.

In essence, the selection of the 6061-T aluminum alloy for this structural application represents a judicious synthesis of material science and engineering acumen, aligning seamlessly with the overarching goal of optimizing the maintenance area for enhanced operational efficacy and longevity. These are the main mechanical properties of the alloy mentioned above:

Mechanical properties	SI
Ultimate Tensile Stress	310 MPa
Yielding Stress	276 MPa
Elasticity Modulus (Young's modulus)	68,9 GPa

The structural design necessitates the capacity for it to be lifted by two operators in a manner conducive to their comfort and safety.

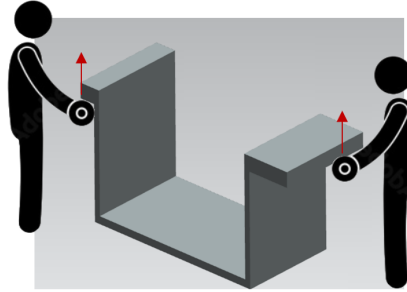

Fig. 7: Operators lifting

Additionally, it is imperative that the weight borne by the structure equals, if not surpasses, that of one operator's mass. This stipulation derives from the two proposed operator positions:

- 1) **seated on the edge of the structure,**
- 2) **standing on it.**

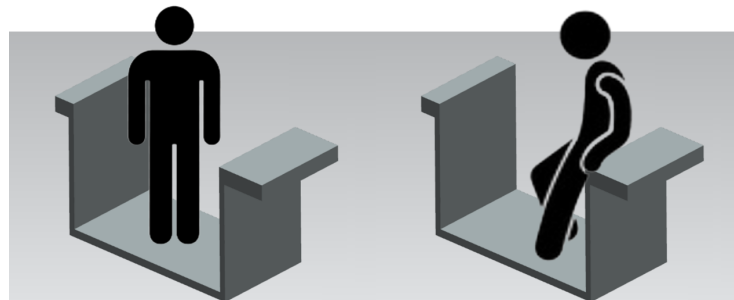

Fig. 8: Operator positions

These considerations underscore the need for judicious restrictions on the weight specifications, a matter that will be expounded upon in subsequent paragraphs.

Furthermore, these weight constraints are essential to ensure the structural integrity and stability of the design, given the pivotal roles that operators play in the deployment and handling of the structure. It is imperative that the structure's weight be in equilibrium with or exceed that of an individual operator to ascertain that it remains firmly grounded and secure during its operation. Such precautions are paramount to preempt any undue stress or strain on the operators, thereby safeguarding their well-being. Moreover, these prescribed weight parameters serve to optimize the ergonomics of the structure, affording operators a level of comfort that is indispensable for sustained and efficacious performance. By adhering to these weight specifications, we endeavor to mitigate the potential for operator fatigue or discomfort, consequently enhancing their operational efficiency and overall experience.

3.2 Design and Building the structure

The structure was designed using NX software. The choice was to sketch first the 2D geometry and then use the extrude functionality to give a 3D shape. In the model the platform is constituted by 2 main extrudes (as you can see in the figure below), one flat plate in the bottom and two L-beams in the upper part.

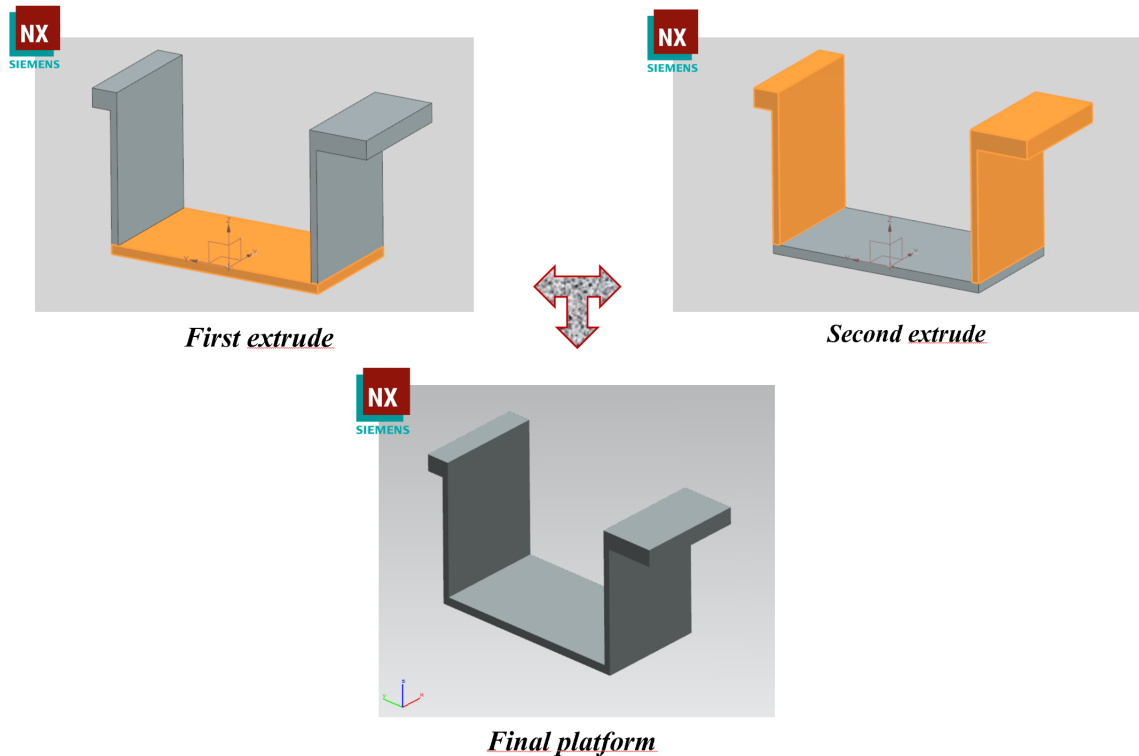

Fig. 9: Platform designed in NX

In practice, it has come to light that the physical components to be utilized in the design deviate from those initially envisaged in the 3D model. Specifically, we will requisition only three plates from the steelworks, whereas the remaining two plates, notably the extensions constituting the wings of the platform, will be repurposed from existing inventory housed within the experiment warehouse. These two plates are slated for repurposing from Aluminum Grates currently in service to cover the trench in the DS Trench area. An illustrative image of the pertinent Grates earmarked for modification into the upper plates of the platform is provided for reference.



Fig. 10: Aluminum Grates present in the experiment warehouse

The assembly of this structure necessitates welding procedures, with a specific emphasis on executing "corner welds" at the junctures between the plates. It is imperative to note that the comprehensive examination of welding methodologies has not been undertaken in meticulous detail, in light of the fact that the final construction of the structure is not slated for immediate implementation. Consequently, a more thorough evaluation of welding techniques will be deferred to a later phase of development.

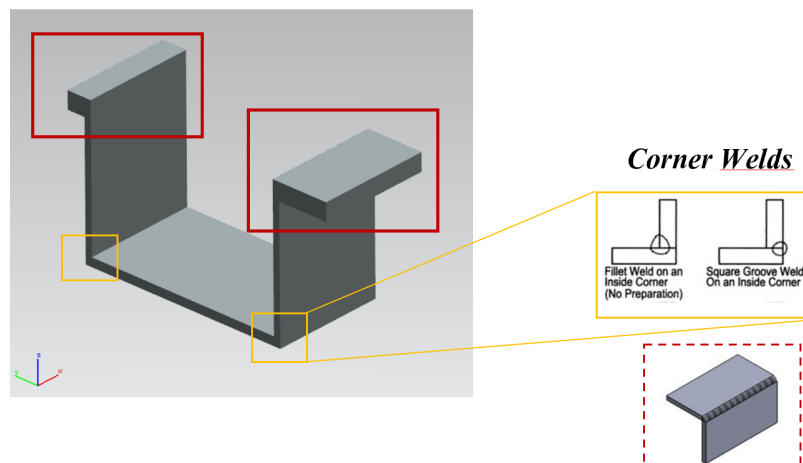

Fig. 11: Preliminar welding system

3.3 Structural Simulations

Several simulations were undertaken to rigorously assess the structural integrity of the platform. To this end, the renowned **Ansys Workbench** software was employed, with a specific focus on the "**Static Structural**" study module. Following the completion of the geometry design using the proficient "**Design Modeler**" tool, the 6061-T material properties were meticulously incorporated within the "Engineering Data" section, and subsequently assigned to the entirety of the structure. This step served as a crucial underpinning, ensuring that the simulation accurately mirrored the anticipated real-world conditions. The structural domain was subsequently discretized into nodes through the application of the "**Regular Mesh**" tool. A paramount consideration in this phase was to ensure the absence of node-to-node interference, thereby fortifying the reliability of subsequent analytical outcomes. It is noteworthy to mention that no further refinements were introduced to the mesh, attesting to the comprehensive nature of the initial meshing process.

With regard to the imposition of constraints and load conditions, a structured approach was undertaken:

- 1) A **fixed support constraint** was judiciously applied to the surfaces in direct contact with the concrete lip. This strategic measure served to emulate the physical support provided by this foundational element, thereby anchoring the platform in a representative manner.
- 2) A **static force**, quantified at 1300 newtons, was meticulously imposed perpendicular to the upper surface of the bottom plate. This imposition was meticulously orchestrated to mirror the operational context, notably aligning with the anticipated position of an operator.

These judiciously formulated constraints and load conditions were meticulously selected to mirror the operational realities and anticipated stress factors that the platform is poised to encounter. This methodical approach ensures that the ensuing simulations provide a robust and accurate assessment of the structural performance, thereby informing any necessary refinements or adjustments in the design.

The ensuing figures afford the reader an insightful glimpse into the outcomes gleaned from the simulations, particularly in relation to the directional deformation and the Equivalent (Von-Mises) Stress. These results bear notable promise, as they unequivocally demonstrate a substantial departure from the plastic deformation regime. It is unequivocally established that the structure consistently operates within the confines of the elastic regime, signifying that it never surpasses the yielding stress threshold. A noteworthy observation is the maximal displacement, which aligns meticulously with the predefined range. This deliberate calibration is pivotal, as it ensures that an operator, subsequent to engaging with the structure, will not experience disorientation.

In the ensuing figures, comprehensive 3D assessments pertaining to Directional Deformations and Equivalent Von-Mises Stress states are presented. Regarding Directional Deformations, our focal point lies in the vertical maximal displacement of the bottom plate, localized at the midpoint of the platform along the central axis of symmetry, aligning with our initial expectations. Remarkably, this displacement is negligibly small, measuring a mere 0.2 millimeters. Thus, it unequivocally places us within a secure operational margin.

Turning to the Stress analysis, it is noteworthy that the highest values manifest in the center of the bottom plate and at the juncture where the lateral plates interface with the bottom plate. Even in these instances, we encounter no cause for concern, as the peak value remains well below 9 MPa. Given that the material's yield strength stands at 276 MPa, we have an ample margin of safety.

In consideration of the operator's mobility on the platform, a dynamic load assessment was contemplated. However, we opted to forego this analysis under the conservative premise that the application of static loads has ensured a substantial margin from the onset of plastic deformation. Additionally, by incrementing the static load by 20% to 30% to emulate dynamic behavior, we find ourselves still significantly distant from conditions that could lead to yielding.

These discerning results are testament to the rigorous analytical scrutiny that the platform design has undergone. The commitment to uphold structural integrity while prioritizing the safety and comfort of operators underscores the meticulous engineering approach. These findings fortify the confidence in the platform's viability and validate its suitability for operational implementation.

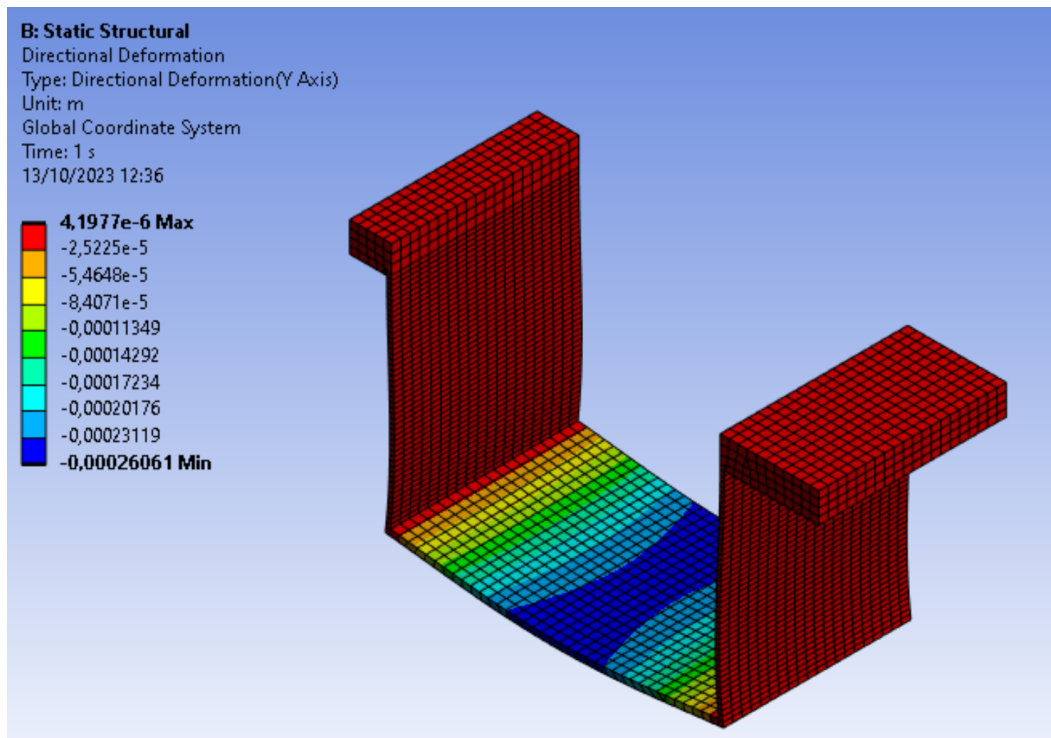

Fig. 12: Directional deformation

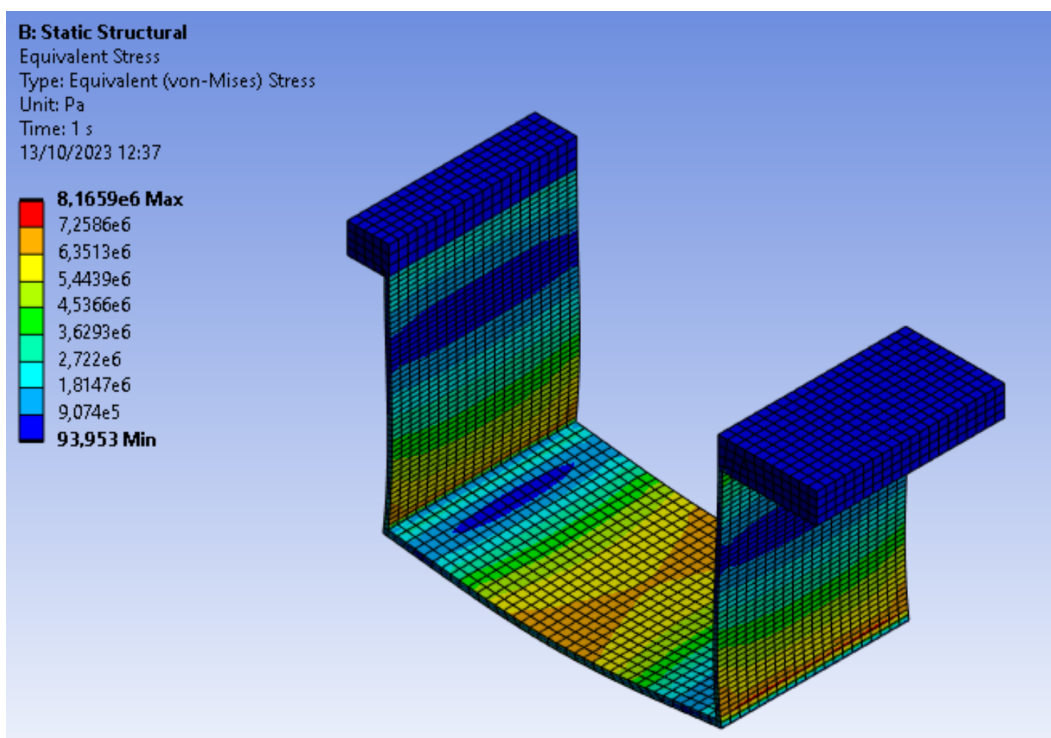

Fig. 13: Equivalent (Von-Mises) Stress

3.4 Placement Constraints

The aluminum platform's support will be provided by the concrete structure of the DS Trench, a specifically designed cavity **situated within the Muon Beamline sector**, spanning beneath the entirety of the detector train. I need to remind that there is a lip in the "DS Trench concrete" zone of about 2.5 inches height. The platform will sit on this lip and the upper plates will be sited at the same height of the floor level. Within this trench, a network of cables is meticulously routed along the lower section, notably encompassing those associated with the Calorimeter and the Tracker subsystems. To the right-hand side of the trench, the structural considerations are further compounded by the presence of chilling pipings, which further define the parameters within which the platform's design must operate. The constraints incumbent upon the structure are manifold and are comprehensively elucidated in the accompanying figures. These visual representations **taken from the real site**, serve as indispensable blueprints, delineating the exacting specifications that the platform must adhere to.



Fig. 14: DS Trench Constraints - Real site

By assimilating and judiciously incorporating these constraints into the design framework, we endeavor to ensure not only the structural integrity of the platform but also its seamless integration within the pre-existing infrastructural elements of the DS Trench. Foremost among these considerations is the imperative to ensure that the platform's load-bearing capacity is judiciously distributed across the concrete substrate. This necessitates a meticulous analysis of the load-bearing points and the corresponding stress distributions, with a view towards averting any undue concentration of forces that may compromise the integrity of the trench's concrete infrastructure. This analysis will be omitted in the report. Moreover, the presence of intricate cable networks, particularly those associated with the Calorimeter and Tracker systems, imposes an additional set of constraints. The platform's design must factor in the precise routing and accommodation of these cables, ensuring that they are adequately protected from any potential mechanical or environmental hazards that may arise during the platform's operation. The right-hand wall of the trench, which accommodates chilling pipings, introduces yet another layer of complexity. The platform's design must carefully navigate this spatial constraint, guaranteeing that it coexists harmoniously with these

pipings without impeding their functionality or compromising their structural integrity. In summation, the design of the aluminum platform within the DS Trench is a multifaceted undertaking, replete with a spectrum of constraints and considerations. By meticulously addressing each of these parameters, we endeavor to craft a platform that not only meets the stringent standards of structural robustness and functionality but also seamlessly integrates within the existing framework of the DS Trench, thereby augmenting the overall operational efficiency of the Muon Beamline sector.

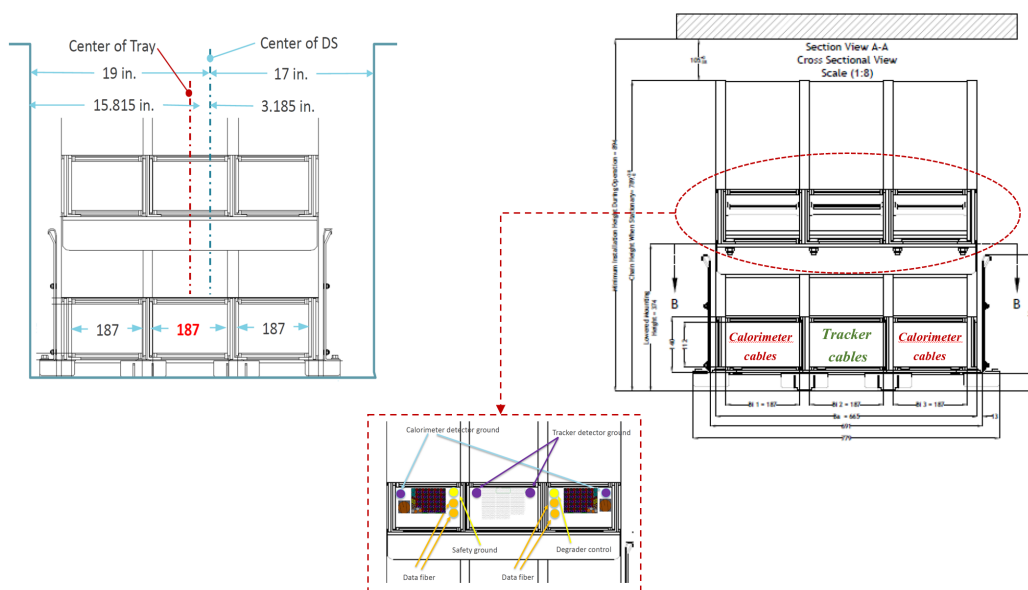

Fig. 15: DS Trench Constraints - Technical drawings

After the 3D design of the structure using NX software, the platform was inserted in the 3D Model of the Mu2e Experiment under the assembly "**Detector Support and Installation System**". No interference was found during this phase. The reader can have a look to the final result in the next figures.

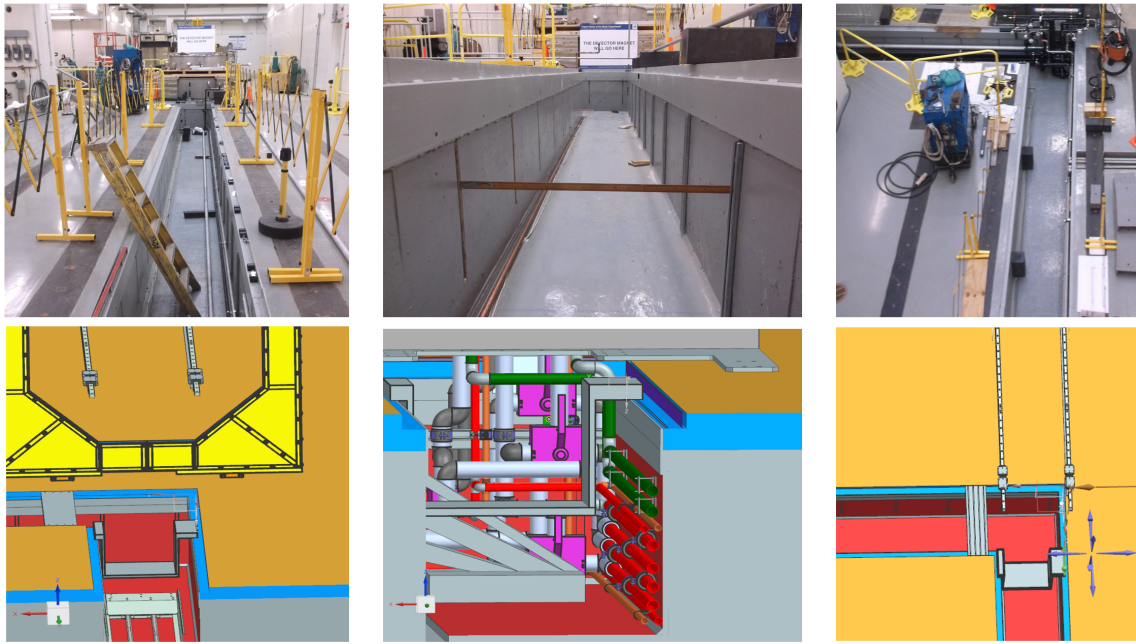

Fig. 16: Placement-1

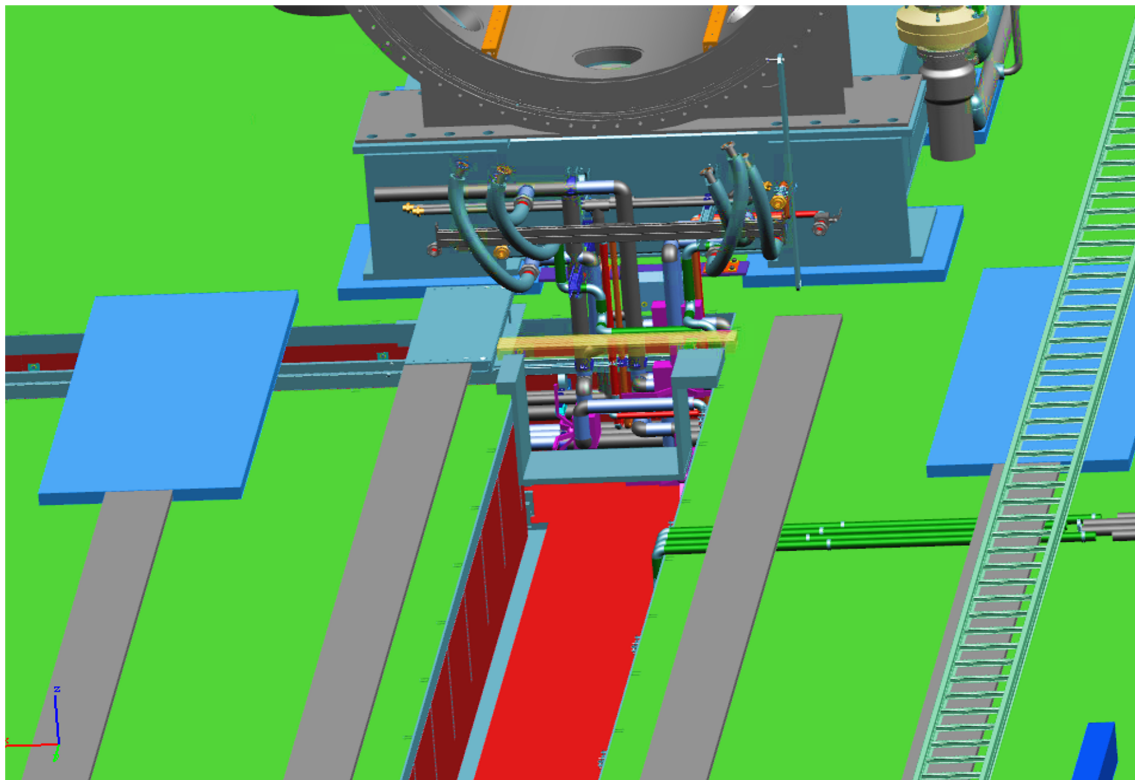

Fig. 17: Placement-2

3.5 Weight analysis and Optimization

The sole challenge encountered pertained to the weight of the structure. As previously discussed, it was imperative that the platform remain manipulable by two operators, each with a capacity to handle a maximum of approximately 25-30 kilograms. Consequently, the aggregate weight of the structure could not exceed twice this specified limit. Given the inherent mass of the plates, calculated without employing any weight-reducing measures, the total weight of the structure approximated 75 kilograms. This presented a significant issue, prompting a systematic exploration of various strategies aimed at weight reduction. Multiple approaches were considered and subsequently discarded until an optimized solution was reached. The ensuing paragraphs expound upon this iterative process:

Initial Concept: The initial proposal involved the symmetric drilling of the bottom plate, incorporating small apertures or rectangular channels (or alternative patterns). This option was dismissed on grounds of cost-effectiveness and concerns regarding potential compromise of mechanical integrity.

Secondary Approach: This strategy entailed the reduction of the thickness of both the bottom and lateral plates, complemented by the introduction of reinforcing ribs on these same plates. Regrettably, this approach proved unfeasible for weight reduction purposes, as it was not viable to remove such a substantial volume of material.

Tertiary Proposal: This proposition involved dividing the structure into two parts and implementing a bolted connection. This design modification would render the structure mountable and dismountable, a significant enhancement. However, careful consideration must be given to identifying the most appropriate bolted connection. It is anticipated that a dual-bolt configuration on each side will be required to mitigate rotational displacements. This method achieves a 50 percent reduction in weight, rendering the structure well within the lifting capacity of each operator.

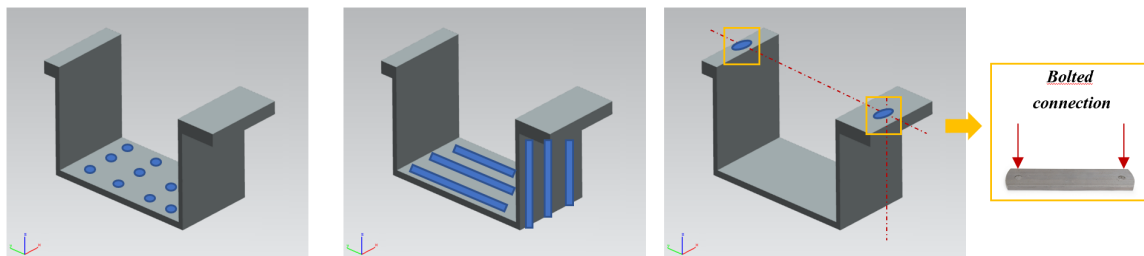

Fig. 18: Proposals: 1-2-3

Final and Simplified Approach: The subsequent recourse, and ultimately the most straightforward, entailed a reevaluation of the structure's weight, considering the wing plates not as thick plates but rather modeling them after the cut grates already present in the laboratory storage. By introducing voids, a reduction in weight is anticipated. The crux of the matter lies in precisely ascertaining the actual weight of the structure and quantifying the resultant reduction.

The latter approach proved to be the most pragmatic. Over the ensuing month, an Excel file was meticulously developed to facilitate a precise estimation of the final structure's weight. Another salient issue addressed pertained to the third dimension of the structure. Prior to the implementation of the authentic grates, an estimated dimension of 40 centimeters was postulated. Subsequent to modeling the grates, a parametric analysis was conducted, establishing a direct correlation between the third dimension of the structure and that of the laboratory's existing grates. This parameterization enables a judicious determination of the number of grates necessitating modification and offers insight into the ultimate third dimension of the platform. The Excel file, integral to this iterative refinement process, is provided in the subsequent figure.

As depicted in the Excel file provided, assuming N to be 4 (representing the number of blocks in each wing of the structure), the total weight of the assembly is projected to be approximately 31 kilograms. This calculation affirms the viability and practicality of this chosen operational approach. This meticulous assessment lends confidence to the feasibility of the proposed methodology, reinforcing its suitability for the intended application.

4 Second Task: Cleaning the 3D model

The second objective of the internship was predominantly aligned with the integrated modeling group.

Integrated Modeling (I.M.) stands as a transformative approach in engineering and design, fundamentally elevating project efficiency and precision. Its benefits are manifold: foremost, it enables precise measurements even for those without extensive field experience, relying on digital modeling for accurate dimensions and specifications. Additionally, I.M. empowers remote measurements, particularly invaluable in scenarios with limited physical access, simultaneously saving time and enhancing safety protocols. Moreover, the enhanced readability of 3D models, as opposed to traditional technical drawings, expedites decision-making and diminishes the likelihood of misinterpretation. I.M. also facilitates comprehensive interface and interference analyses, allowing for the proactive resolution of conflicts prior to physical assembly. Particularly adept at handling intricate and irregular shapes, it excels in managing complex geometries. The system also enables meticulous tracking of component versions, crucial in large-scale projects with frequent updates, ensuring constant accessibility to the latest specifications. With the capability for seamless version comparison, engineers can astutely evaluate changes and enhancements, informing precise design iterations. Furthermore, I.M. enables the digital simulation and construction of installation processes, a critical feature for precise planning and sequence optimization, ultimately minimizing on-site complications. Through these capabilities, I.M. revolutionizes the engineering and design process, enhancing the quality and efficiency of projects. As industries increasingly integrate advanced digital technologies, Integrated Modeling emerges as a cornerstone in modern engineering practices.

The ultimate goal of the internship was to rectify elements within the 3D model. This encompassed the removal of certain components, meticulous adjustment of their placement, restructuring of assemblies and sub-assemblies, and executing precise alignments. In the ensuing sections, I will offer a comprehensive overview of the tasks I meticulously undertook during the process of refining and fine-tuning the 3D model of the Mu2e experiment.

4.1 Detector Train Assembly

The Detector Train assembly encompasses all the essential components housed within the Muon Beamline. This assembly includes various elements as depicted in the accompanying illustration:

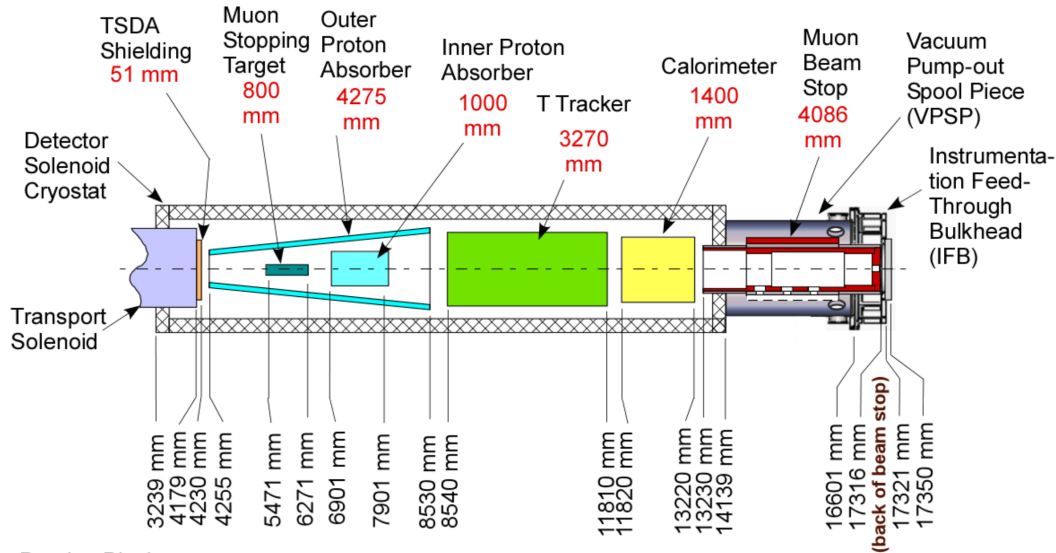

Fig. 20

The Detector Train assumes two distinct positions during its operational phases:

- 1.Inserted Position:** This configuration is adopted when the experiment is actively collecting data during its runtime.
- 2.Extracted Position:** This mode is engaged during periods of experiment shutdown and subsequent maintenance activities.

The primary distinction between these two positions lies in the spatial arrangement of the components. In the Inserted Position, the Detector Train is housed within the inner bore of the detector solenoid. Conversely, in the Extracted Position, the Detector Train is extricated from the inner bore of the DS through the utilization of a specialized rail system, both internal and external.

Within these subassemblies, the following operations were executed and in the process of managing the Detector Train in the Extracted Position, a meticulous series of steps were undertaken. This commenced with a comprehensive assessment of the positioning of vital components, including the Instrumentation Feedthrough Bulk-head (IFB) , Muon Beam Stop (MBS), Stopping Target, Outer Proton Absorber (OPA), Inner Proton Absorber (IPA), Tracker, and Calorimeter.

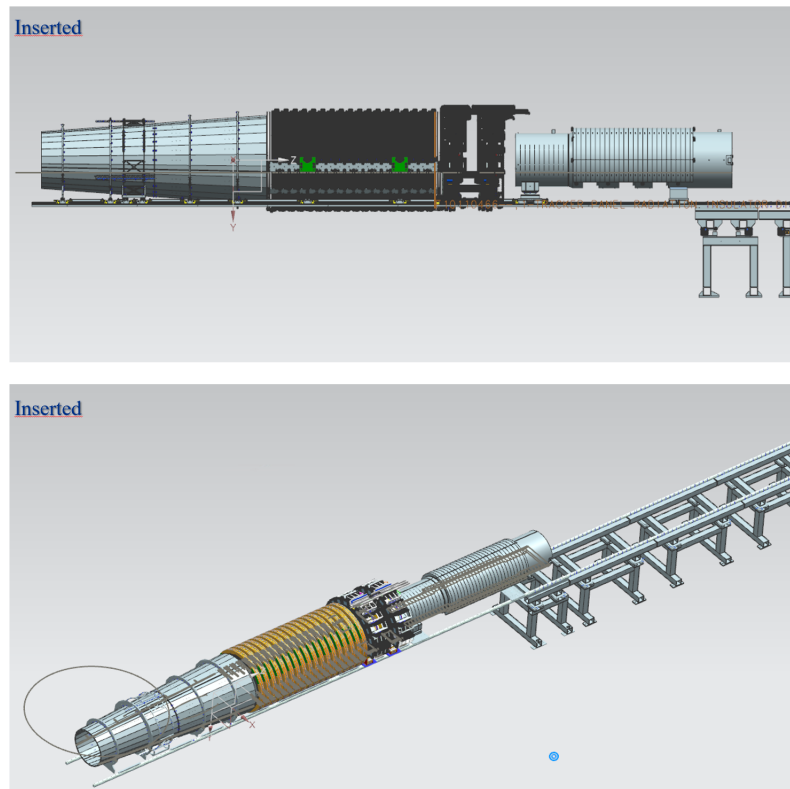

Fig. 21: Inserted position - the MBS is in the interface between internal and external rail system

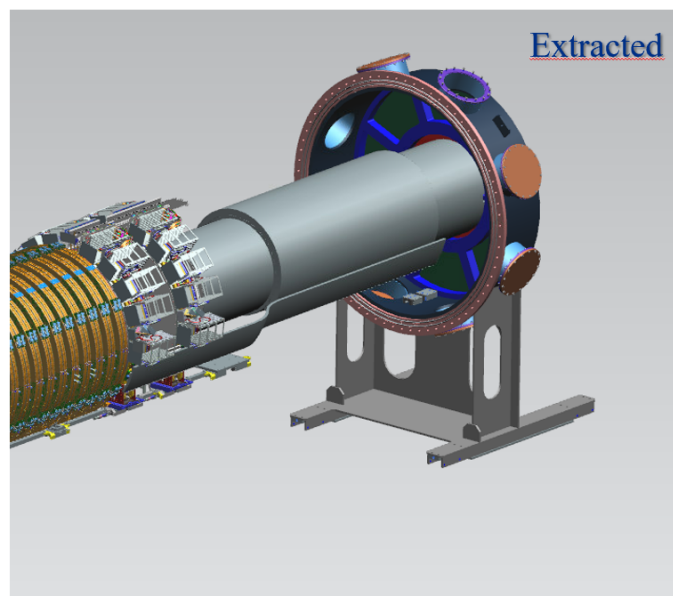

Fig. 22: Extracted position - the MBS is close to the IFB

To ensure seamless integration, the cables and pipings from the previous Calorimeter were accurately duplicated, followed by the careful removal of the obsolete Calorimeter disks. The previous version of the Calorimeter was then reinstated within the Conceptual Assembly.

Precise spatial alignment was of paramount importance, necessitating adherence to the designated x,y,z Mu2E coordinates, as well as meticulous attention to their relative positioning, as stipulated in the technical blueprints. Additionally, the determination of the "Extracted Position" relative to the IFB flange was essential, culminating in the development of a structured Maintenance Procedure for future reference.

With the Extracted Position successfully established, the focus shifted towards fine-tuning the coupler assembly and ensuring optimal placement of the Detector Train in the Inserted Position. This phase of the project represented a critical juncture, as it required a seamless transition from one operational state to another, ensuring the Detector Train's optimal functionality in both configurations.

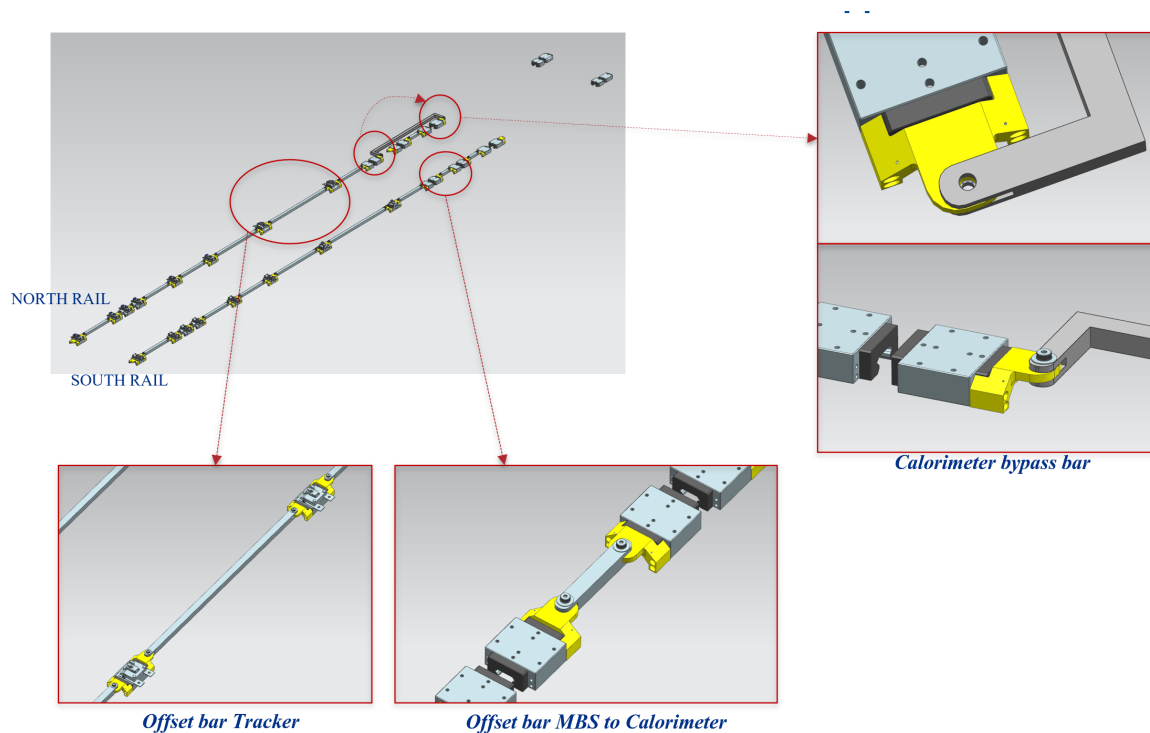

Fig. 23: Coupler assembly - Final Result

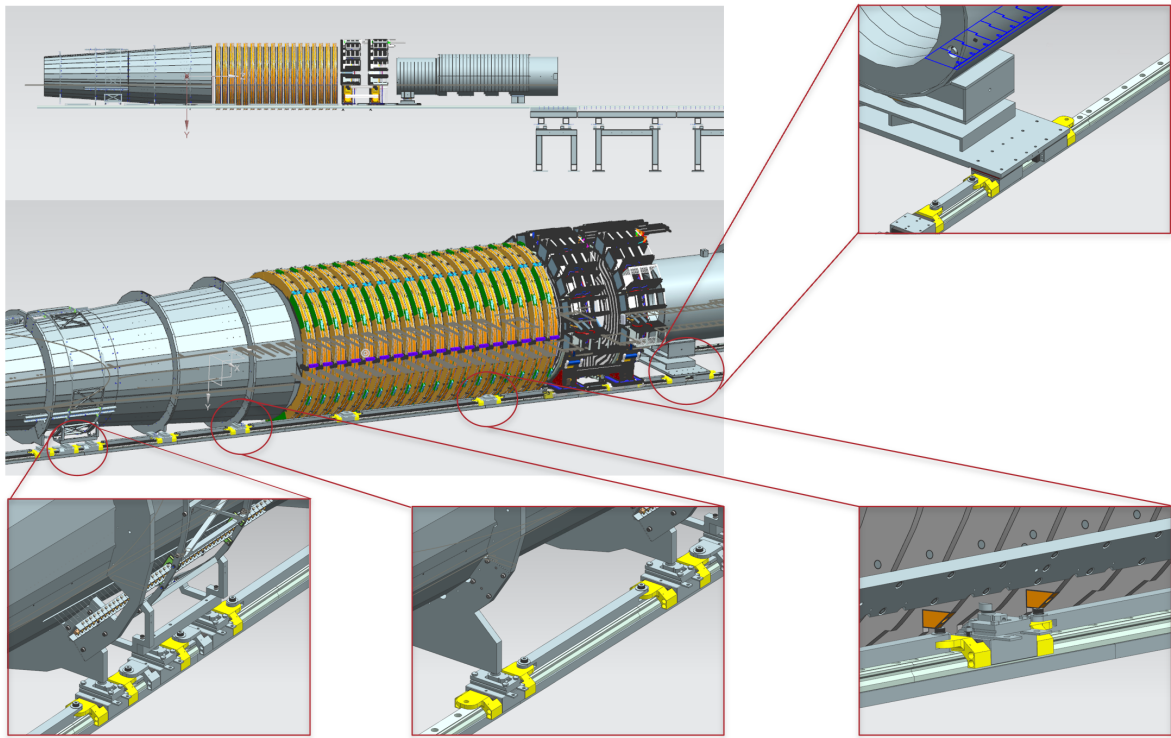

Fig. 24: Detector Train - Final Result

4.2 DS Trench and Cables Assembly

A significant focus was directed towards the reorganization of the "Trench Components – DS and TS subassembly". This involved the establishment of new subassemblies, namely the "Trench Cover Components – TSd and DS", "Pipe Chase Alcove Slot Covers", and "DS and DS Cross Trench Covers". Notably, the high-capacity trench plate, which serves as an extension of the floor plate across the DS cross trench, appeared to be correctly positioned. However, it was observed that the DS trench corner plate was situated in an incorrect location. In the initial phase of the internship, a notable discrepancy was identified concerning the width of the Ds Trench in the NX model, which deviated from the specifications outlined in the Technical Drawings. Consequently, measures were taken to adapt and reconfigure the grates to ensure a proper fit within the trench. Moving forward, there is a planned initiative to modify the concrete structure in accordance with the specifications detailed in the drawings, thereby rectifying this incongruity and aligning it with the prescribed dimensions. This endeavor underscores the commitment to precision and adherence to technical specifications in the ongoing development of the project. Furthermore, in the subsequent tasks, attention was directed towards rectifying discrepancies in the placement and alignment of trench components within the DS Trench area: Noted the overlap between the High Capacity Trench plate and DS Trench Grating Corner Plate, potentially stemming from an inaccurate relief width associated with the DS trench concrete structure. Corrected the positioning of the DS Trench Grating Corner Plate, ensuring it was correctly situated in the north-south orientation

adjacent to the High Capacity Trench plate. This adjustment may have initially appeared unconventional due to the aforementioned concrete relief width irregularity. Generated a new trench plate with the precise length required for the DS trench (39.25" in length), designating it under the newly established subassembly "DS and DS Cross Trench Covers". Ensured the assignment of the MU2e System Integration properties. Positioned the new trench plate at the identical Z coordinate as the westernmost instance of the "Grate, Aluminum Heavy Duty Unpunched Trench", while also accurately aligning it north-south with its center at Mu2e X = -3929.4 mm. Placed additional copies of the correctly sized trench plate in their designated locations across the DS trench, adjacent to the westernmost trench plate. Relocated the three westernmost instances of the "Grate Aluminum Heavy Duty Unpunched Trench" from the extreme west end of the DS trench to the area between the high capacity trench plate and the floor plate intended to support the south side of the end cap shielding over the DS cross trench. Transferred the remaining two copies of "Grate Aluminum Heavy Duty Unpunched Trench" and introduced supplementary copies of the same component across the DS cross trench on the south side of the floor plate meant to support the southern aspect of the end cap shielding over the DS cross trench. This was done to ensure complete coverage of the aisle path with these trench plates. It is with satisfaction that I report that all of these procedures were executed successfully, resulting in the desired alignments and placements of the trench components within the DS Trench area. Several figures follow in the report.

The last step involved in the process of this macro-assembly was the importation of the STEP file labeled "DS Trench Cable Management System" (modeled by Igus company). This digital file encapsulates crucial information pertaining to the cable management system within the DS Trench. Following the importation, meticulous attention was given to the precise positioning of this file within the overall assembly. This step was critical in ensuring that the cable management system seamlessly integrated with the existing components in the DS Trench. Subsequently, to facilitate a more organized and manageable workflow, two distinct subassemblies were created. The first was denoted as "Echain", encompassing internal components relevant to the e-chain system. The second, termed "Echain Trough", pertained specifically to the external structural components of the e-chain. The outcomes of these steps and their impact on the overall configuration are visually depicted in the accompanying figures, providing a comprehensive visual representation of the integration of the cable management system into the DS Trench assembly.

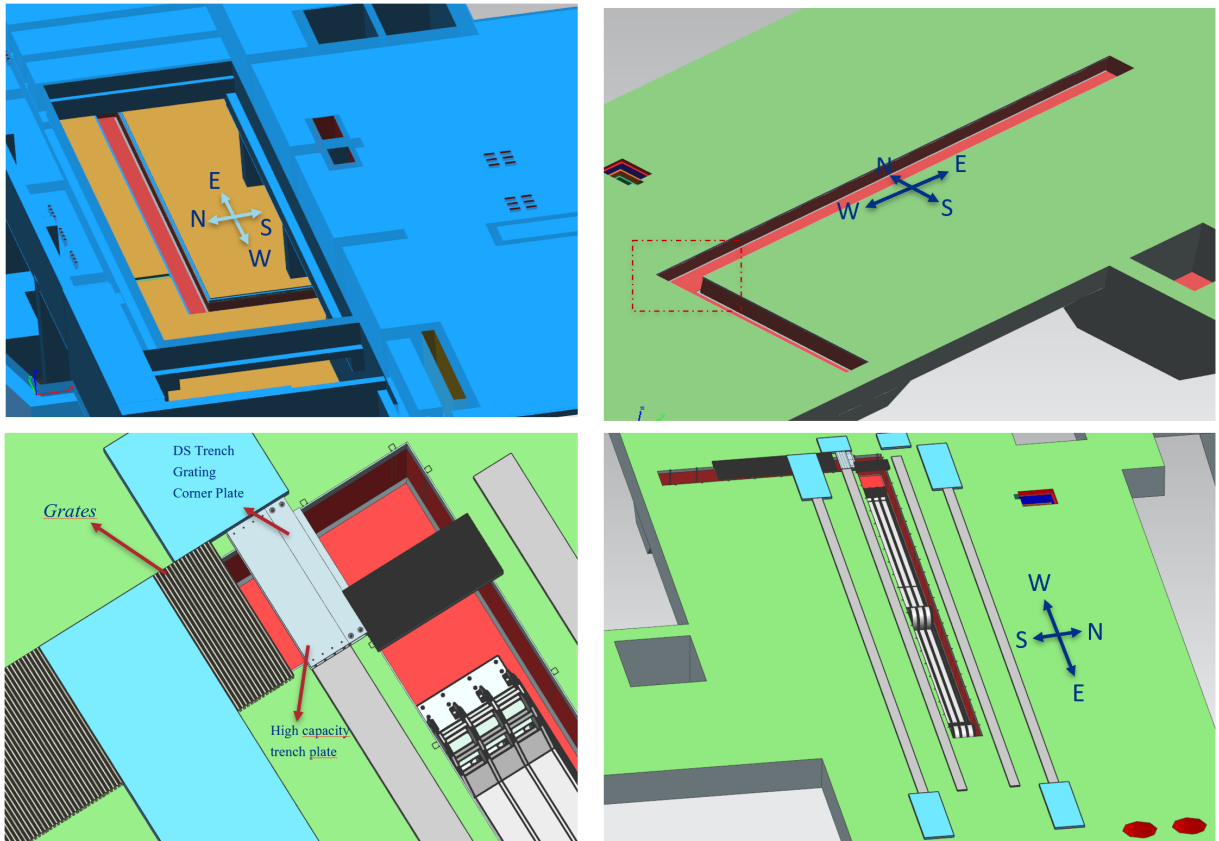

Fig. 25: DS Trench Area - Final Results

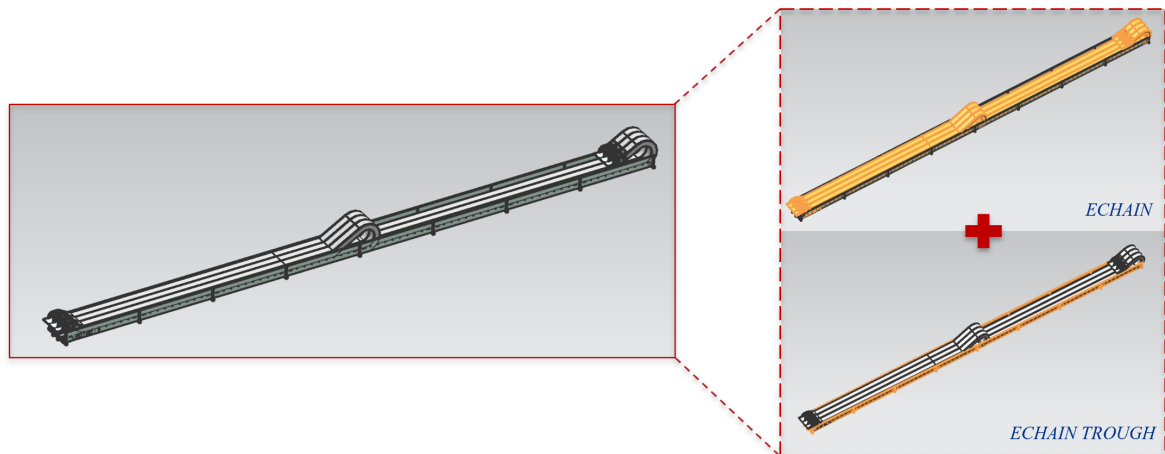

Fig. 26: Sub-assemblies DS Cable Management System

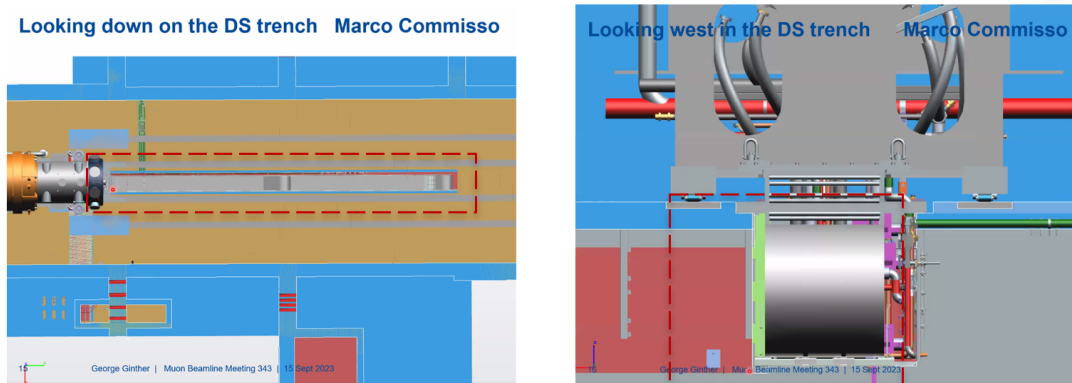

Fig. 27: Placement DS cable management system

4.3 Shielding Assemblies

Numerous corrections were pursued within the shielding assemblies. These operations can be summarized into four overarching tasks:

Task 1: Reconfiguration of Hatch Block Shielding

For the TS Hatch Blocks, a division was made into two distinct subassemblies: "Lower" and "Upper" levels. Similarly, for the DS Hatch Blocks, a separation into "Lower" and "Upper" subassemblies was executed. Within the Lower subassembly, further subdivisions were created for the "East" and "West" sides. The same procedure was applied in the Upper subassembly.

Task 2: Rearrangement of Remote Handling Hatch Blocks

The orientation of the bottom two layers of the SP-9 hatch blocks was strategically adjusted to optimize the beam positioning. This involved aligning the 3' dimension vertically (up and down) instead of the previous orientation, which was from east to west. A new subassembly named "Bottom Level Remote Handling Hatch Blocks" was established to distinctly differentiate the Lower Part from the higher part.

Task 3: Extinction Monitor Hatch Blocks Enhancement

The upper levels of H blocks underwent a reorientation to enhance crack coverage. The installation approach was modified to include four 1.5' thick layers, as opposed to the previous arrangement of two 3' thick layers, with each layer accommodating two side-by-side blocks.

Task 4: Model Generation for Shield Block Installation Guides

A model was generated to serve as shield block installation guides, subsequently incorporated into a dedicated subassembly named "Shield Block Alignment Guides". These guides function as stops and locators during the shield block installation process. The design considerations included the exploration of potential angles or L-shape beams (either 6"x3"x3/8" or 4"x2"x1/4") positioned inboard of the inside edge of the shielding. The leg dimensions of the chosen angle were strategically oriented to maximize contact with the shield blocks while ensuring sufficient clearance room.

All of the aforementioned procedures were executed with precision and meticulous attention to detail, resulting in successful reconfigurations and enhancements within the Mu2e experiment's assembly. These adjustments have significantly contributed to the overall functionality and structural integrity of the experiment. [\[Gin23a\]](#) [\[Gin18\]](#) [\[Gin23b\]](#) [\[Gin16\]](#)

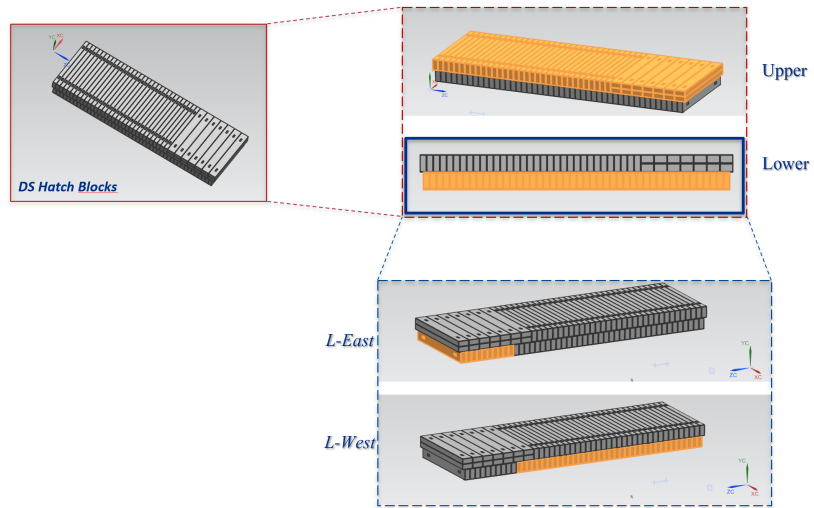

Fig. 28: DS Hatch Block

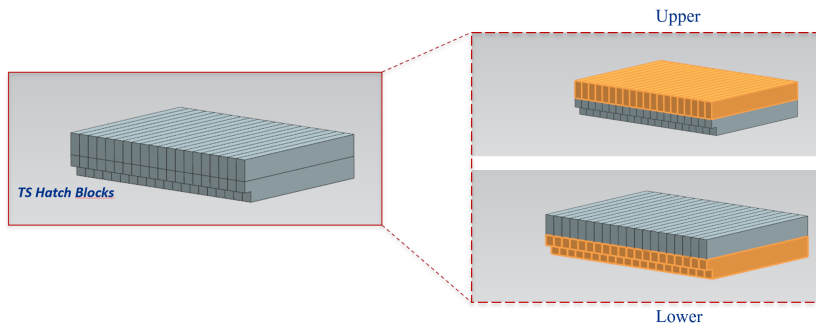

Fig. 29: TS Hatch Block

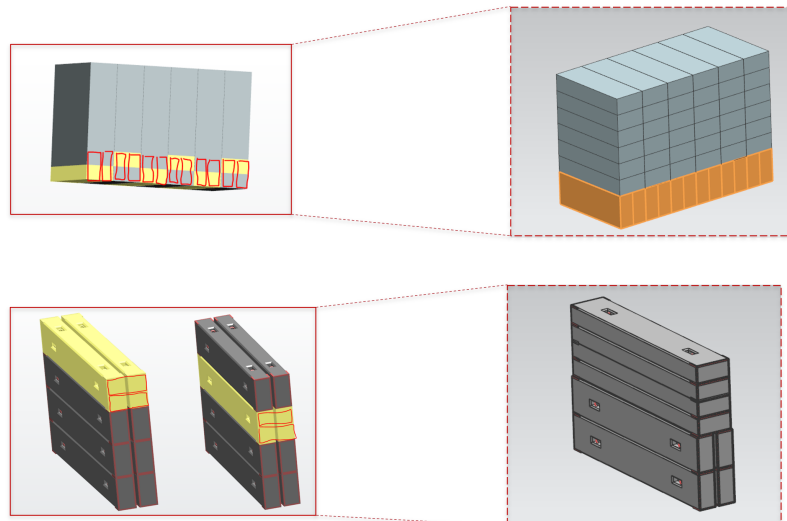

Fig. 30: Remote Handling Hatch Blocks and Extinction Monitor Hatch Blocks

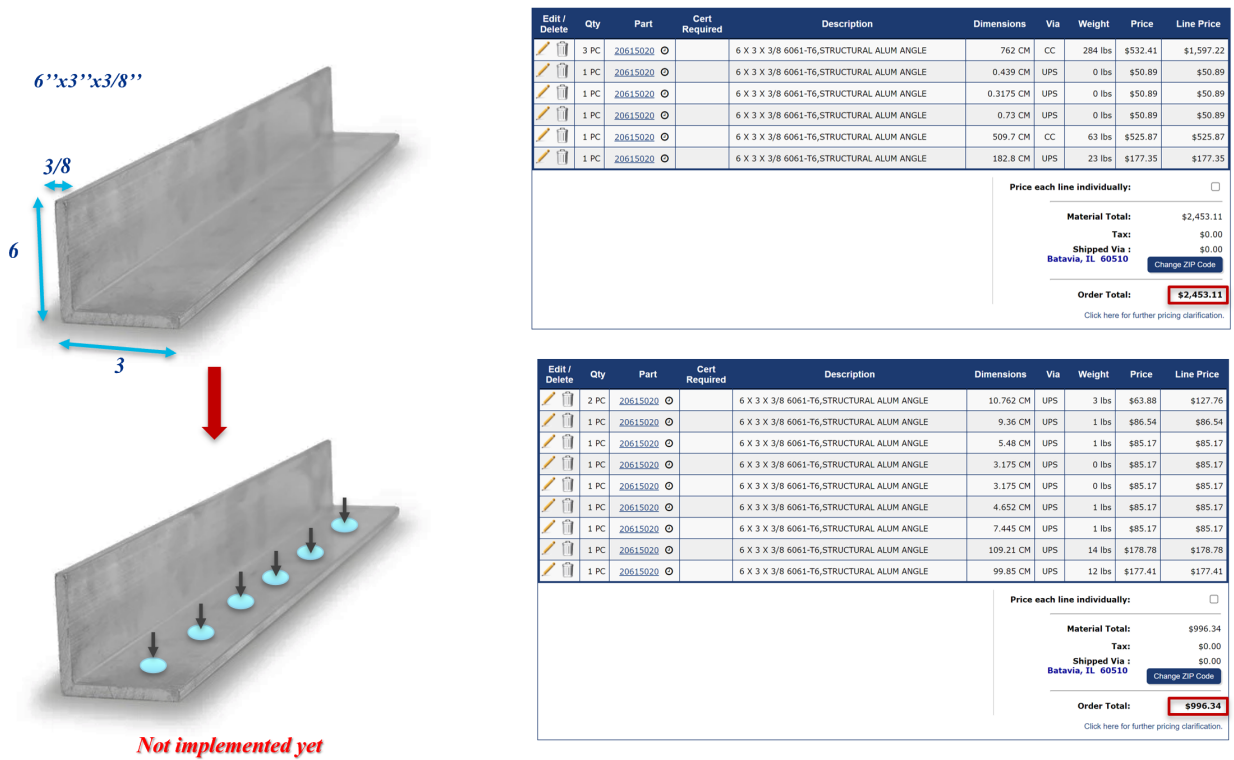

Fig. 31: Shield Blocks Alignment Guides - 1

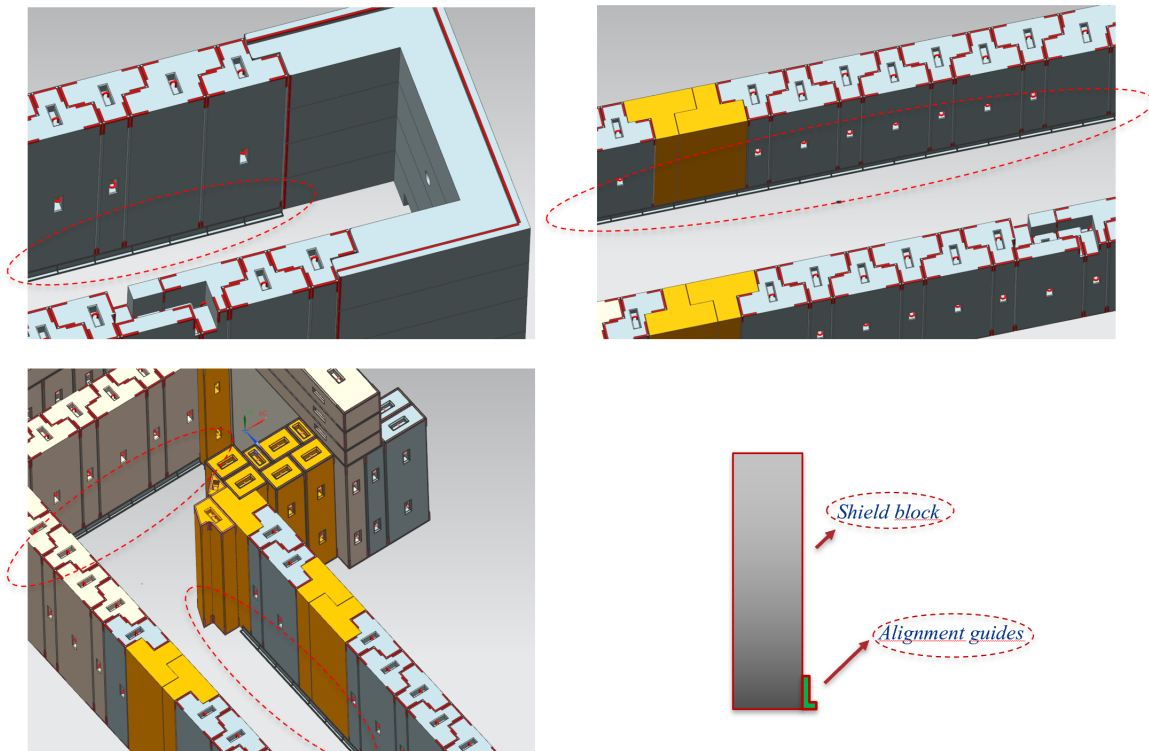

Fig. 32: Shield Blocks Alignment Guides - 2

5 Conclusion and perspectives

"Engineering is the art of organizing and directing men and controlling the forces and materials of nature for the benefit of the human race." - Henry G. Stott

In summation, the immersive summer internship undertaken at Fermilab, with a dedicated focus on the Mu2e Experiment within the Mechanical Integration and 3D CAD Modeling group, stands as a profoundly constructive and edifying professional engagement. The internship program was strategically structured into two distinct phases, each affording an in-depth exploration of pivotal facets within the domains of mechanical design and 3D modeling.

During the inaugural stage, the focus was on the detailed design of a specialized aluminum platform tailored for DS Trench Maintenance. This phase showcased a thorough examination of structural integrity, careful material selection, and the precise application of engineering principles.

Additionally, the internship involved critical tasks related to Integrated Modeling, a cornerstone in modern engineering practices. This approach not only streamlined measurements and interface analyses but also facilitated precise planning and sequence optimization for installation processes, ultimately enhancing project efficiency.

The internship also included significant efforts in reorganizing and optimizing various components within the 3D model, particularly in the Detector Train Assembly, DS Trench, Cables Assembly, and Shielding Assemblies. These tasks involved adjustments, reconfigurations, and enhancements, all executed with meticulous attention to detail.

Overall, this internship provided invaluable hands-on experience in the realm of mechanical design, 3D modeling, and integrated engineering practices. The accomplishments achieved in refining and fine-tuning the Mu2e experiment's 3D model, alongside the successful design and analysis of the aluminum platform, are a testament to the dedication demonstrated throughout the internship. The skills and insights gained during this experience will undoubtedly serve as a strong foundation for future endeavors in the field.

References

- [Gin16] George Ginther. “Requirements and Specifications WBS 5.2 MUON BEAMLINE VACUUM SYSTEM v5”. In: *Mu2E Docdb 1481* (2016).
- [Gin23a] George Ginther. “DS Trench Cable Management System and related updates v1”. In: *Mu2E Docdb 45689* (2023).
- [Gin23b] George Ginther. “Mu2e Muon Beamline Interface Control Document v16”. In: *Mu2E Docdb 1168* (2023).
- [Gin18] Ray R. Ginther George Bossert R. “Requirements and Specifications WBS 5.10 DETECTOR SUPPORT AND INSTALLATION SYSTEM”. In: *Mu2E Docdb 1383, v7* (2018).