

Time profile analysis of photodetector signals in multi read-out calorimetry with Ghz samplers

F. Bedeschi, M. Bitossi, R. Carosi, M. Incagli,
R. Pegna, F. Scuri

INFN, Pisa

CALOR 08, Pavia, 27/5/2008

- Introduction
- Hadron calorimeters energy resolution
- Dual readout
- Q/S method
- Detection of Cherenkov light
- Time structure analysis
- Domino Ring Samplers
- Proposed layout
- Examples of time analysis
- The future

Hadron calorimeters

- Poor energy resolution:
 - different response for e.m. and non-e.m. components ($e/h > 1$)
 - large fluctuations between the two components (f_{em})
- Improving the energy resolution:
 - compensating calorimeters, off-line compensation, Particle Flow Analysis, Dual readout,

Dual readout calorimetry

- Measurement of f_{em} event by event
- Detect scintillation light and Cherenkov light at the same time
- Non-em component is dominated by spallation protons (non relativistic) => scintillation light
- em components, electrons and positrons, are relativistic => dominate the production of Cherenkov light

$e/h \approx 5$ (Cherenkov)

$e/h \approx 1.3$ (Scintillation)

Energy resolution using S/Q

- Hadron calorimeter response

$$Q = E \left[f_{em} + (e/h)_Q^{-1} (1 - f_{em}) \right] \quad S = E \left[f_{em} + (e/h)_S^{-1} (1 - f_{em}) \right]$$

- If (e/h) is known, f_{em} can be calculated event by event using Q/S ratio
 - improved energy resolution, more Gaussian signal distribution
- The shower energy can be determined directly:
$$E = \frac{S - rQ}{1 - r} \quad r = \frac{1 - (h/e)_S}{1 - (h/e)_Q}$$

Detection of Cherenkov light

- Cherenkov vs Scintillation light (Q vs S):
 - Directionality: S is isotropic, Q has $\cos \Phi_c = 1/\beta n$
 - Time structure: Q is prompt, S ~ 10 -100 ns (depends on material)
 - Spectrum: Q $\sim 1/\lambda^2$, S depends....
 - Polarization: Q is polarized, S is not polarized
- $Q < S$
- DREAM used PbWO_4 and BGO

PbWO₄ vs BGO

	PbWO ₄	BGO
density g/cm ³	8.3	7.13
X ₀ cm	0.89	1.12
RM cm	2	2.23
dE/dx MeV/cm	10.2	9
L int cm	20.7	22.8
τ decay ns	50	300
λ max nm	560	480
n	2.2	2.15
Relative output	0.1 (s) 0.6(f)	9
Q/S	~100	1

BGO will be used for the next DREAM test beam, July 2008

Signal time structure measured by DREAM

NJP **10** (2008) 025003

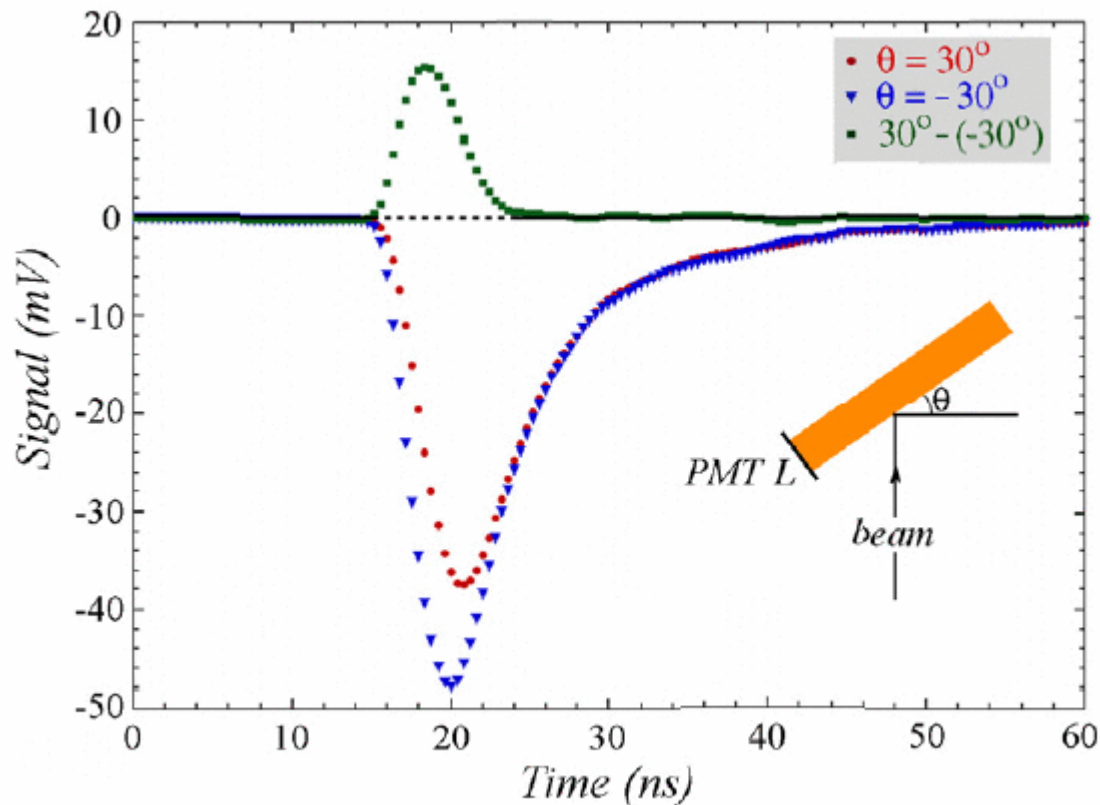

PbW04

10 GeV electrons

at $\phi = -30^\circ$ Cherenkov contributes,
at $\phi = 30^\circ$ it does not.

The difference is the
excess signal
(Cherenkov)

(average over many
events)

(courtesy of DREAM collaboration)

Neutron contribution

- >95% of neutrons are produced in nuclear de-excitation:
 $\langle E_n \rangle \sim 3 \text{ MeV}$
- They lose their energy mainly by elastic scattering
- Energy loss $\sim 1/A \Rightarrow$ free protons dominate the process
- In DREAM plastic fibers: average time between $n-p$ scattering events: 23 ns
- Independent of $E_n \Rightarrow$ expect exponential tail in time structure signal
- E_{kin} loss time constant, including other processes (scattering off nuclei, inelastic) $\sim 25 \text{ ns}$

Neutron contribution - jets

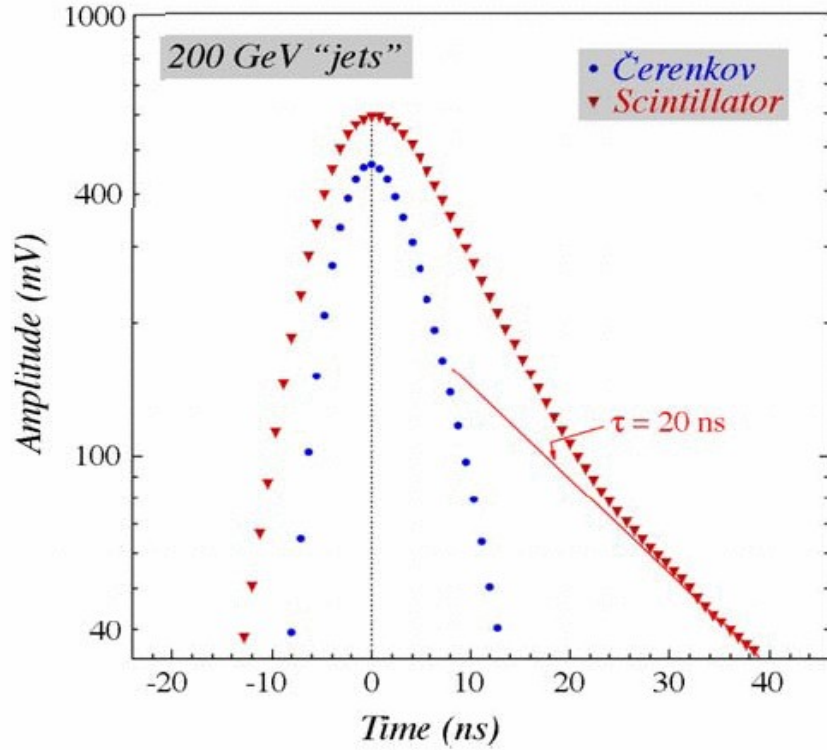

time profile



Cherenkov resolution

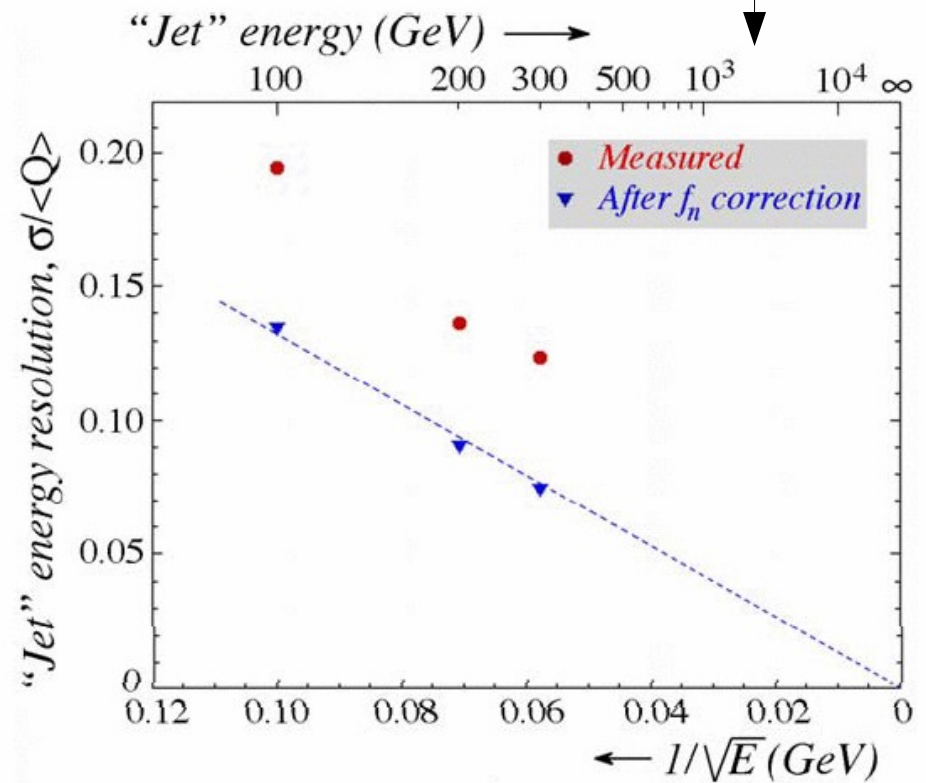

(courtesy of DREAM collaboration)

Time structure analysis

event by event

- Time structure depends on the material
 - optimization in the choice of the material
- Sampling at 1-2.5 Ghz, large time window
 - measure the fast and slow components
- Rate is not a big concern at R&D level
- Use Domino Ring Sampler (DRS)
 - developed at PSI (S. Ritt, NIM A 518,470(2004))
 - used by MEG, MAGIC
 - cheap, compact

Domino Ring Samplers

- It implements a series of Switched Capacitor Arrays (SCA) which allow a fast digitization of the signal at the Ghz level

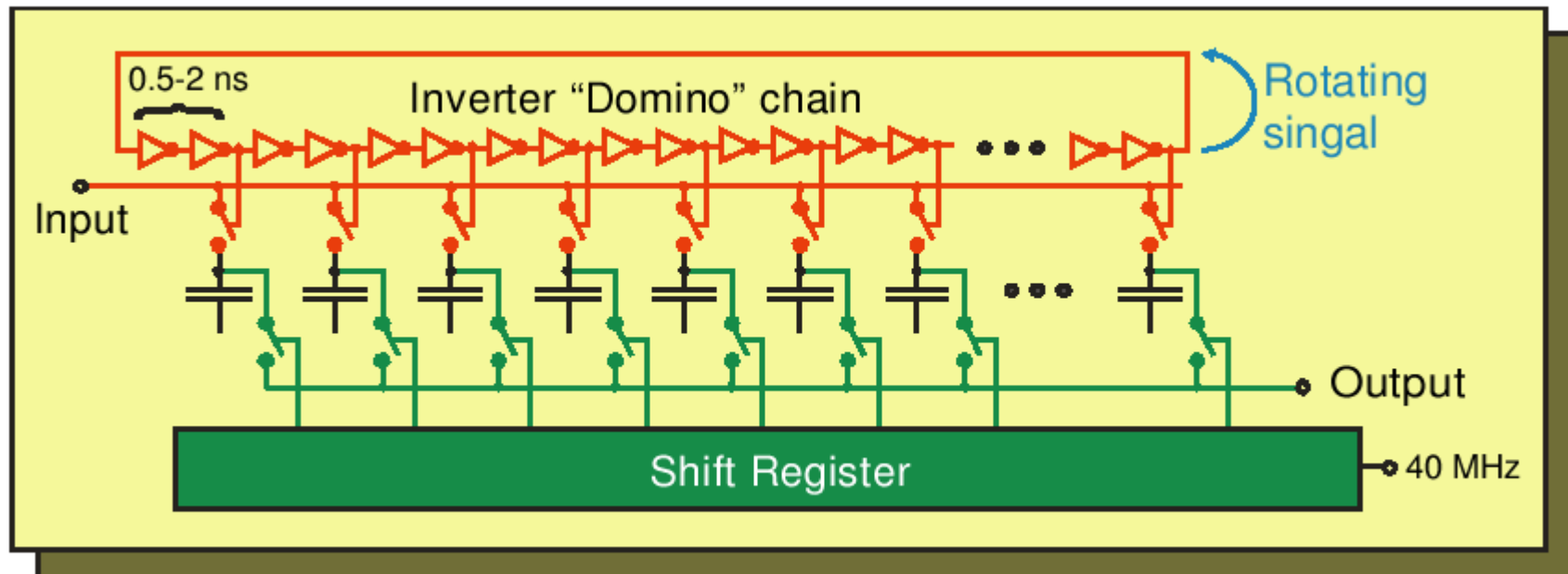

- Current version is DRS 2
- Preliminary lab tests made with a prototype card and early DRS 2 chip batch
 - Each DRS2 chip has 8(+1 for trigger) channels with 1024 cells each – sampling at 2.5 GHz
- With a relatively simple board 2 mezzanines can be mounted
 - possibility to read 16 channels with a 6U VME board – cheap solution, cost ~ 3-30 \$/chn
- Time history of the signal up to ~500 ns
- Cost and power consumption are much less than commercial flash ADCs with same performances (sampling, not rate)
 - 50 mW @ 2GHz
- We can profit from experience of other groups (MAGIC, MEG)

Lab test setup

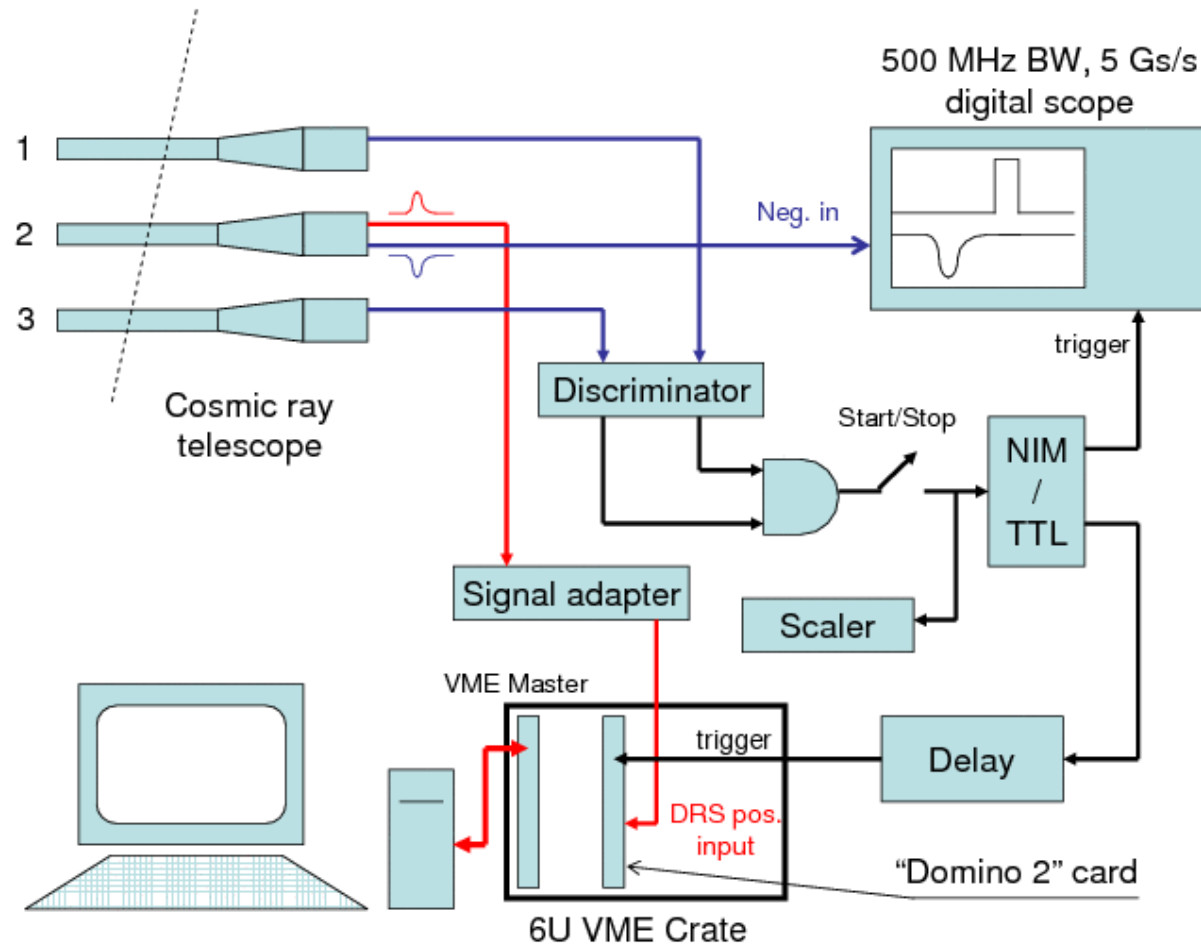

Check the same signals from PM and DRS -> e.g. BW

Most of the hardware and a lot of help from MAGIC colleagues

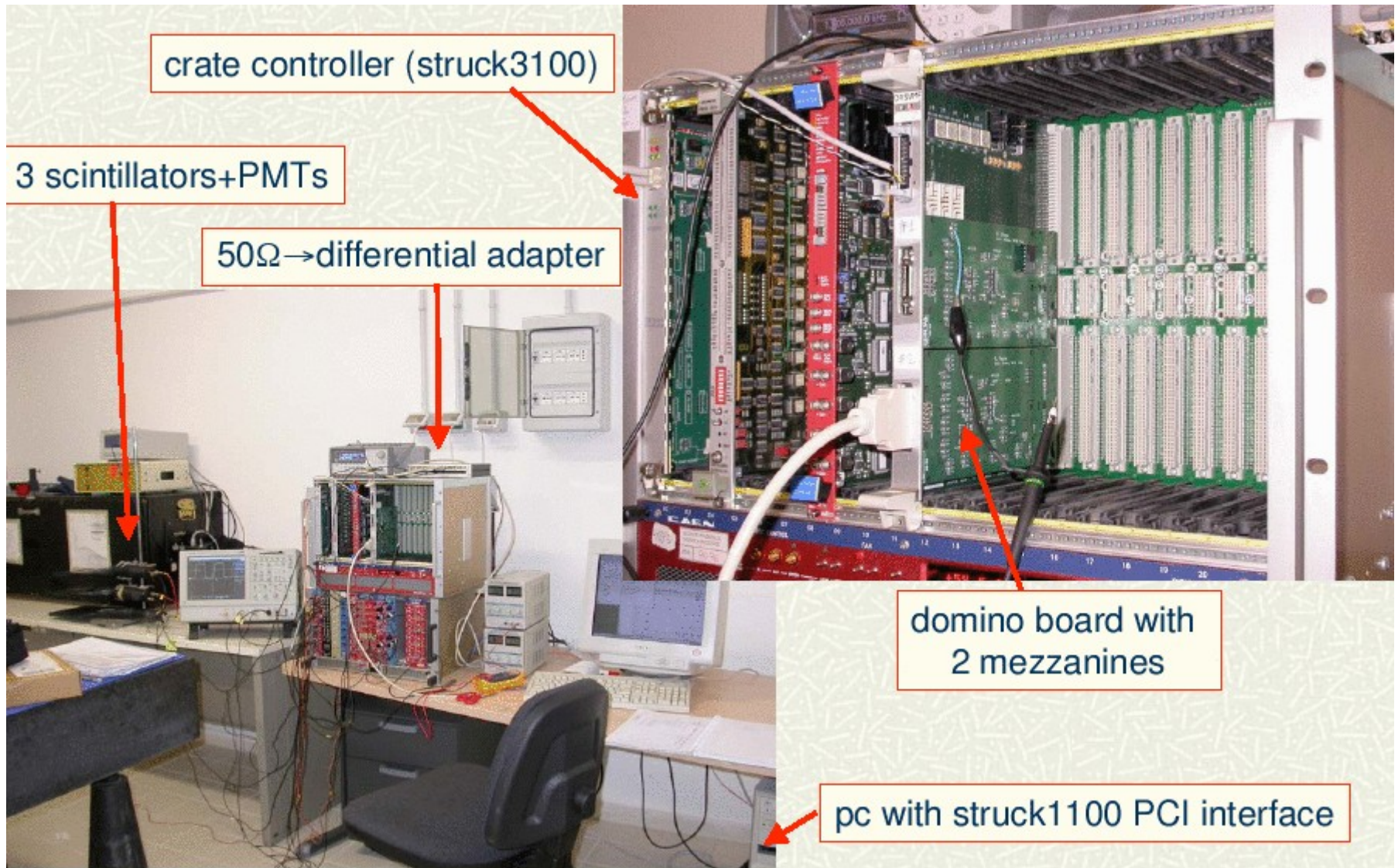

crate controller (struck3100)

3 scintillators+PMTs

50Ω→differential adapter

domino board with 2 mezzanines

pc with struck1100 PCI interface

VME Domino Card

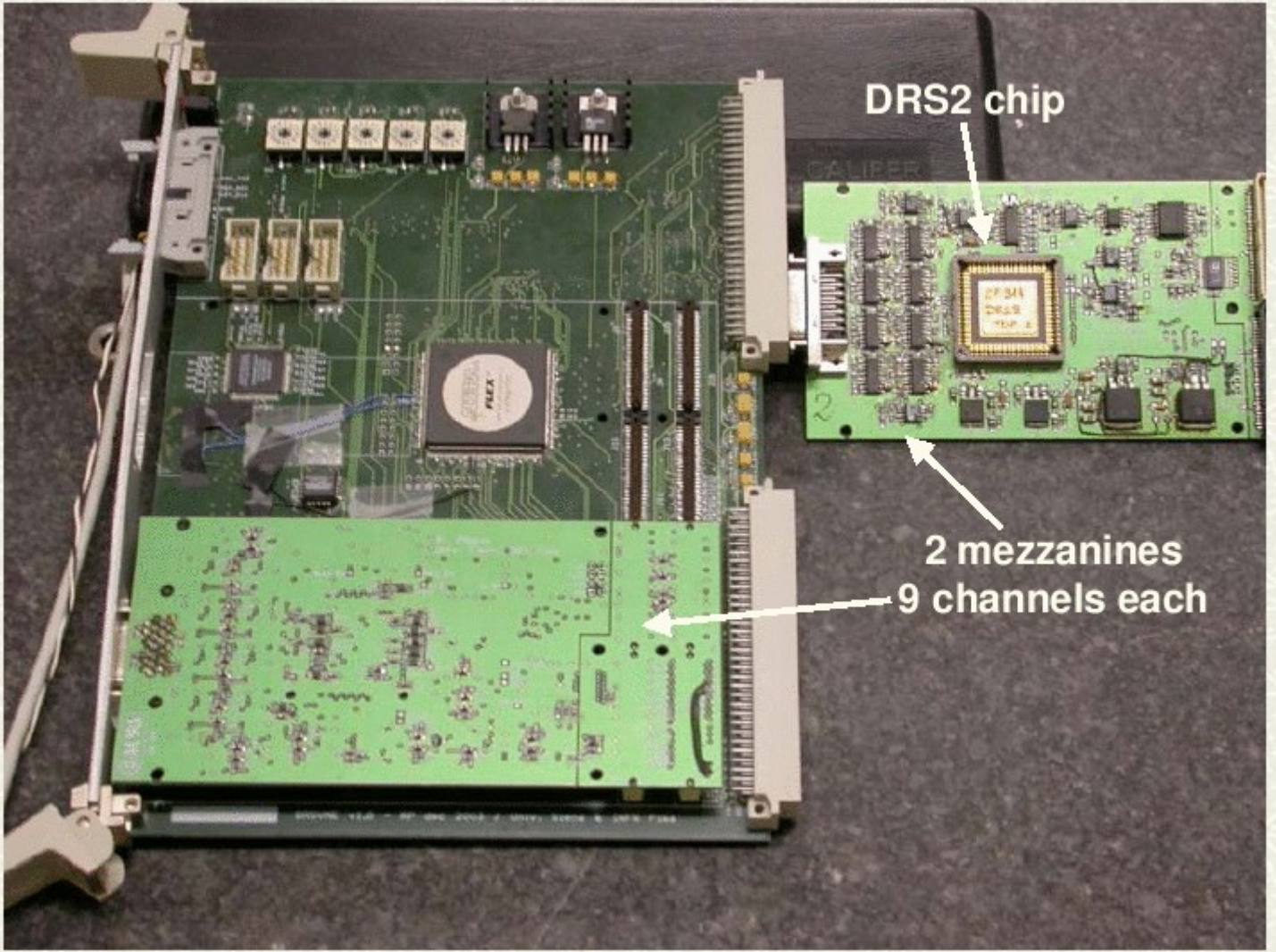

Calibration

- transform from raw ADC counts to mV
- a signal of constant height is sent to all of 8×1024 cells
- the device is almost linear in the range 300-700 mV
- it is possible to add an offset to have the signal positive and in the most efficient range

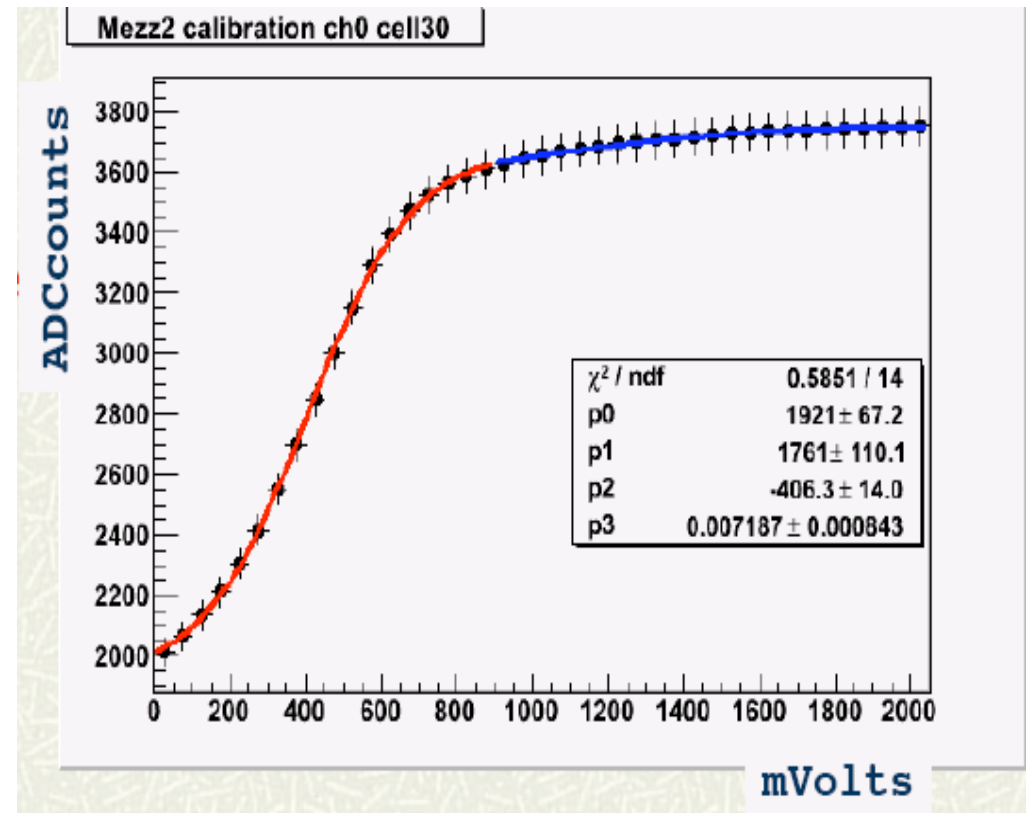

Trigger rate

- send fast triggers with an oscillator and count the rate of events written to output
- the measured max rate is ~ 8 Hz
- this time includes DAQ processes, not optimized for our setup.
- it corresponds to a throughput of $1024(\text{cells}) * 9(\text{ch}) * 4\text{B}(2\text{Bytes per mezzanine}) * 8 \text{ Hz}$
 $\sim 300 \text{ kB/s}$
- far from the VME intrinsic limit 10-20 MB/s

Check: Bandwidth for the test setup

- rough estimation: send a square wave of rise time $\tau_0 \sim 5$ ns;
- the final rise time at DRS input is observed $\tau_2 \sim 11$ ns, which is reproduced at the board output
- this can be translated to an approximate BW

$$f \approx 0.35 / \sqrt{11^2 - 5^2} \text{ GHz} \approx 36 \text{ MHz}$$

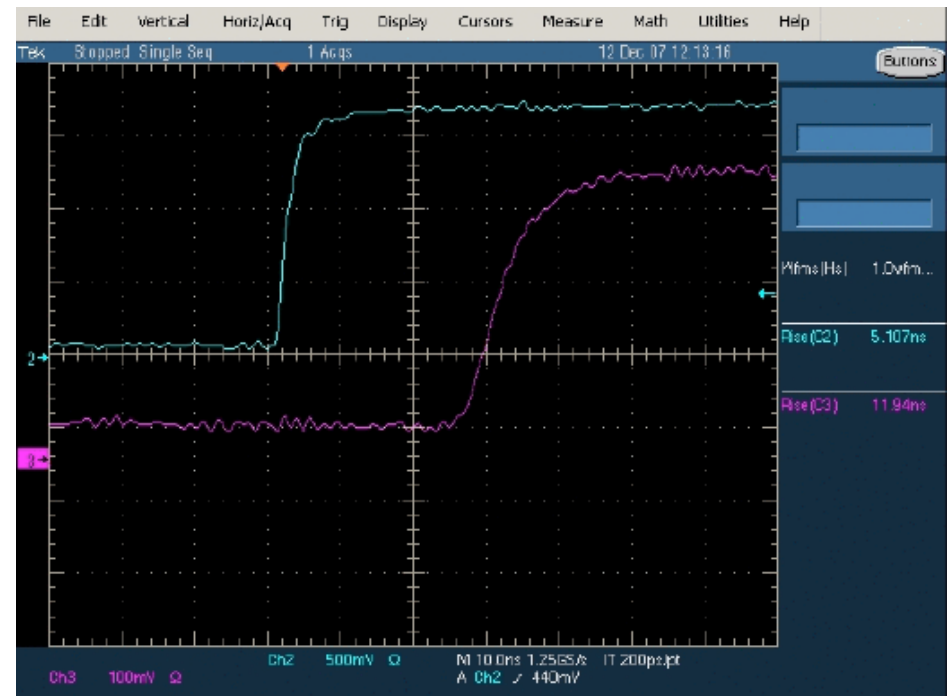

Better estimation: use a cosmic ray signal

compare the raw signal with the signal sampled by DRS

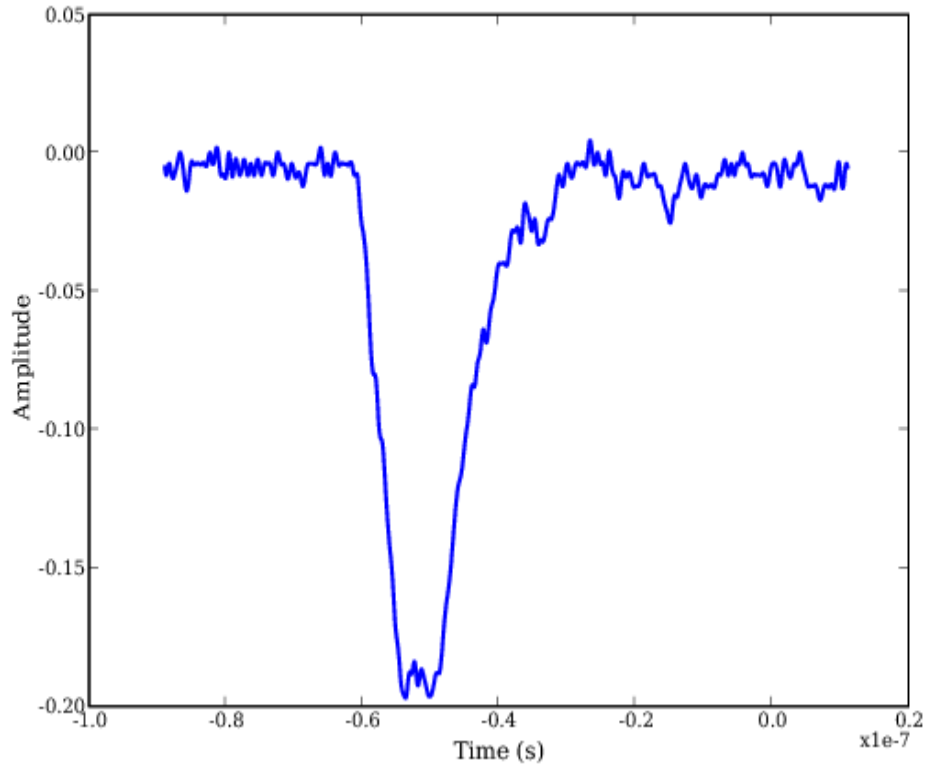

First PM output to digital scope
(500 MHz BW)

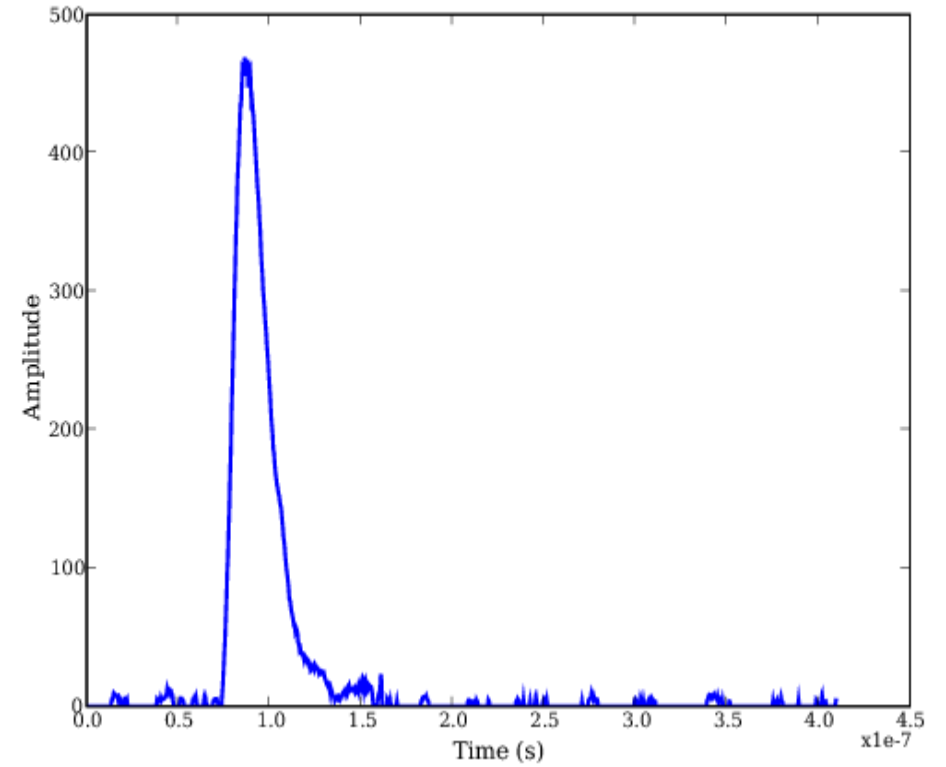

DRS sampled signal from second PM output

Fourier transforms and transfer function

$$G(f) = A_{DRS}(f) / A_{PMT}(f)$$

$f_c \sim 35$ MHz

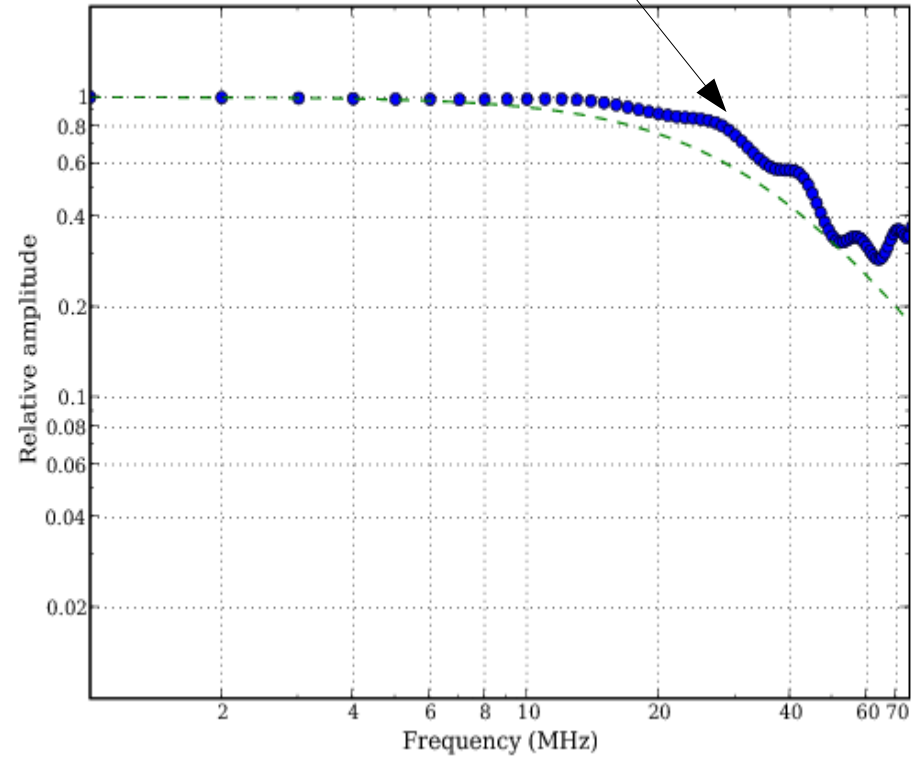
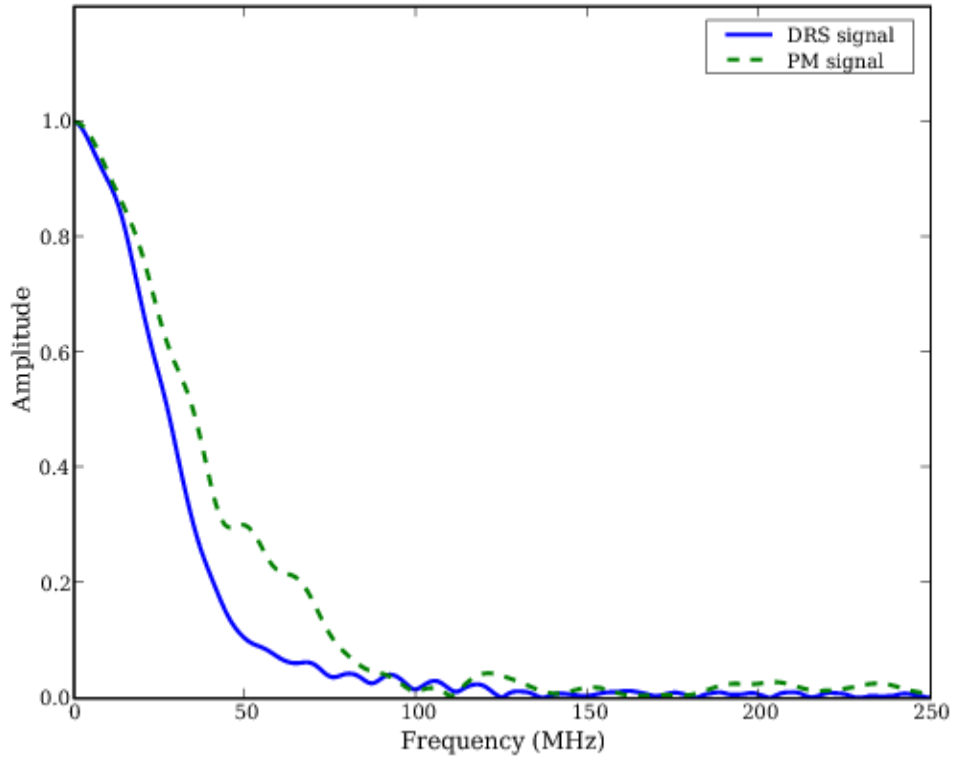

Discrete Fourier transforms
(amplitudes)

DFT amplitude ratio

Bandwidth

- we have estimated the bandwidth of the whole system (cables, electronics,...)
- The main limit of DRS2 is the input capacity of 44pF
- a resistor of 22 Ω was put in series to dump the ringing effect, which results in a corner freq. ~ 200 Mhz
- the reason why we measure 35 Mhz is mainly due to how we evaluate the bandwidth, but also to amplification board, cables, mezzanine input board,....
- we can improve it:
 - modify the input resistor (new mezzanine+Pulsar motherboard) $\rightarrow \sim 10 \Omega$
 - modify the input capacity (new chip DRS3/4)

Setup for the DREAM test beam 2008

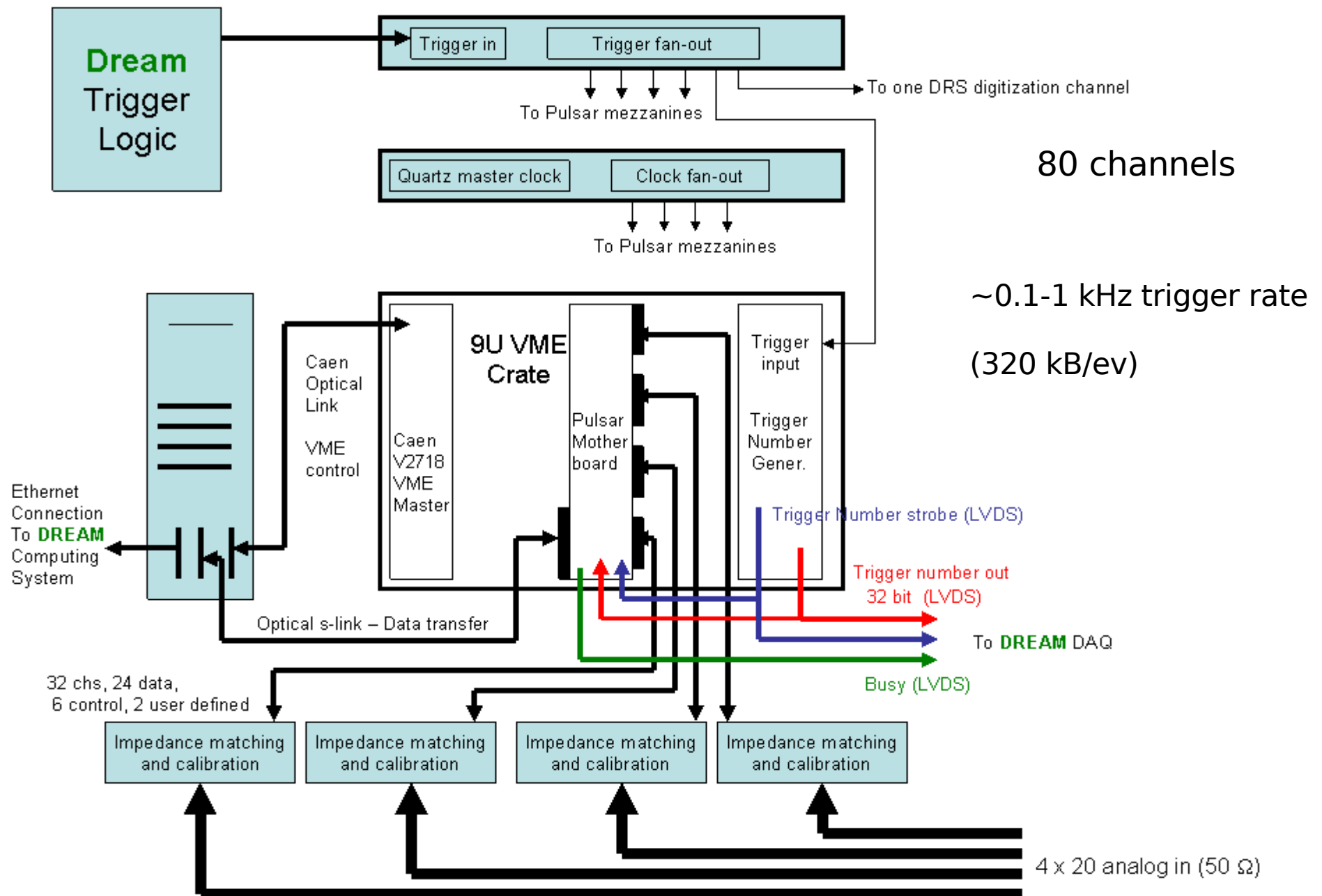

Pulsar

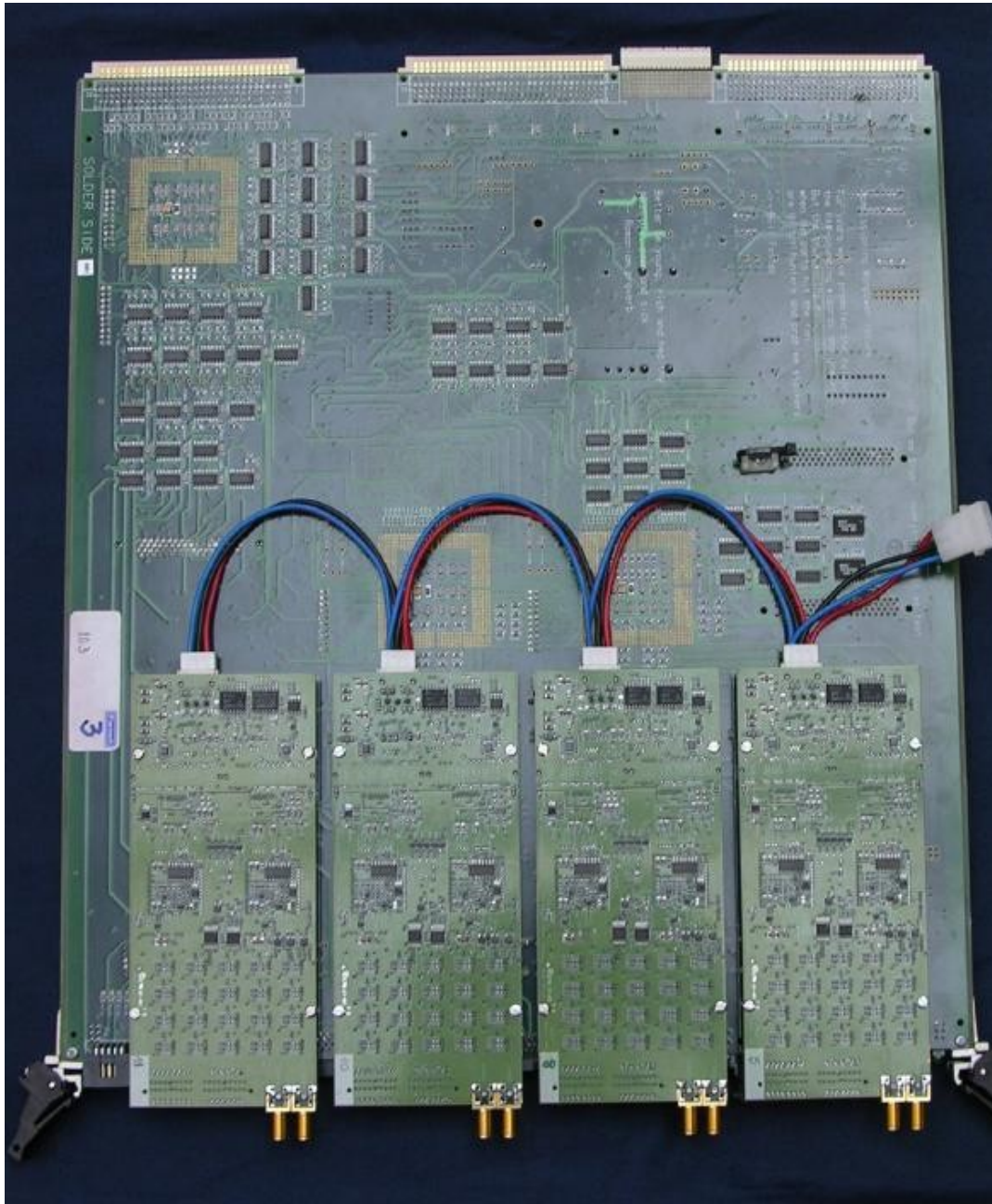

Interface board



Mezzanine with DRSs

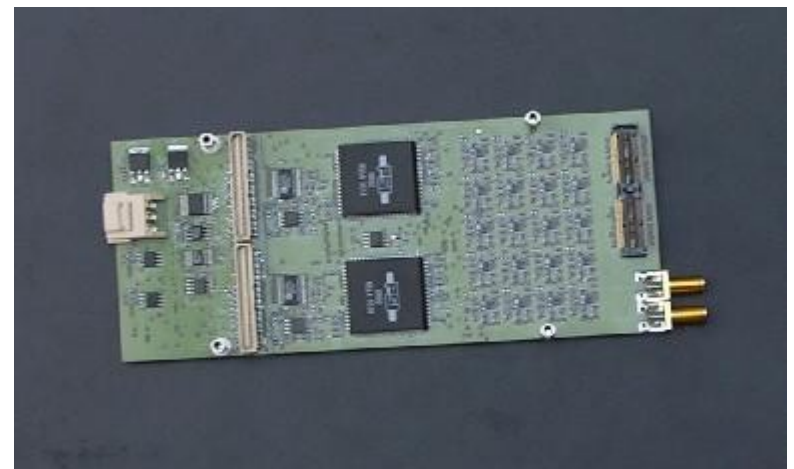

- 1 Pulsar board to read 80 channels
 - 4 mezzanines x 2 DRS each x 10 channels each
 - 19+19 fibers + crystals (full DREAM detector!)
- 1024 time slices per channel, one every 0.4 ns for 400 ns
 - 320 kB/ev
- 0.1-1 kHz rate
- Improved energy resolution thanks to:
 - Q/S separation
 - neutron detection

Conclusions

- We have a system ready to test the detection of Cherenkov light and neutron contribution based on the time profile analysis of signals
- The system technically works
- The system will be tested at Cern this summer with the DREAM prototype
- Thanks to the DREAM and MAGIC colleagues