

Alignment of the CLAS12 RICH

Marco Mirazita

Laboratori Nazionali di Frascati

RICH reconstruction

- estimate the Cherenkov angle for all the hits in the MAPMT plane
 - Ray tracing of Cherenkov photons inside the RICH, based on:
 - the geometry of the detector
 - the charged particle trajectory from CLAS12
- perform the particle ID of each charged track in the detector
 - prior knowledge of the refractive index

The photons can be detected with a large variety of topologies depending on their path in the detector

- Direct photons, no reflections
- One reflection on a lateral mirror
- Two reflections on a spherical and a frontal mirror
-

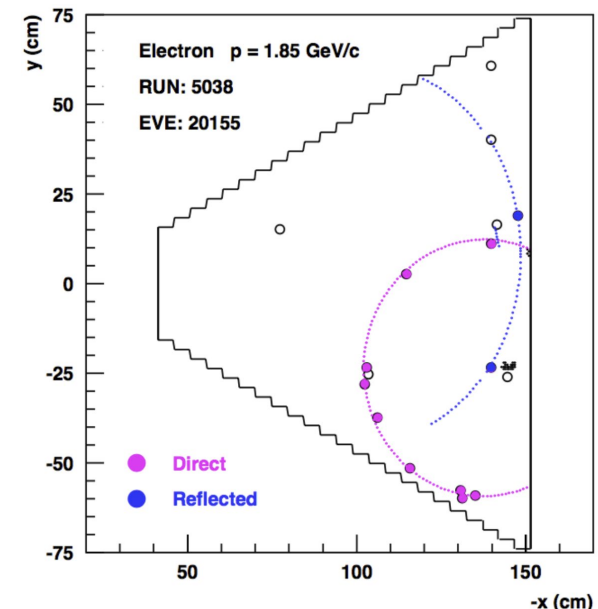
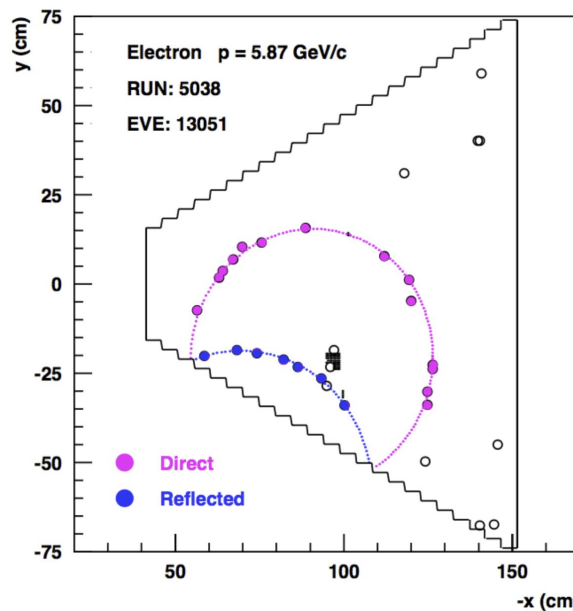
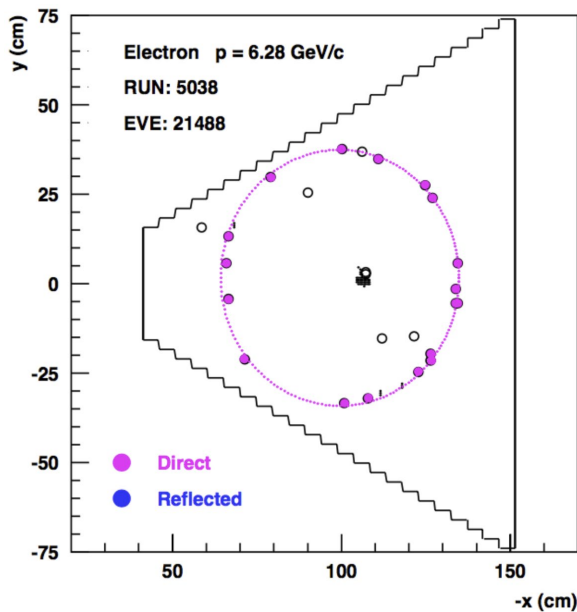
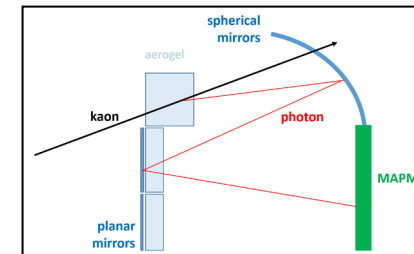
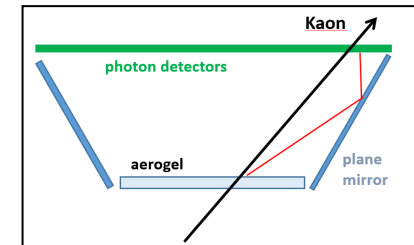
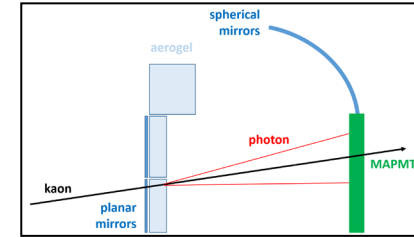

Why do we need alignment?

The PID with the RICH is based on the comparison between the measured and the expected Cherenkov angle

$$\propto \frac{\theta_{meas} - \theta_C}{\sigma_C}$$

Errors in the knowledge of the position of the internal elements lead to a different Cherenkov angle depending on the photon detection topology

- Reference Cherenkov angles and resolutions are tabulated in the CCDB for 3 categories
 - direct photons
 - first reflection on a flat mirror
 - first reflection on a spherical mirror
- Misalignments can affect in different ways positive and negative particles → separate tables per charge
- Non negligible tile-to-tile variations of the refractive index → one set of angles per aerogel tile

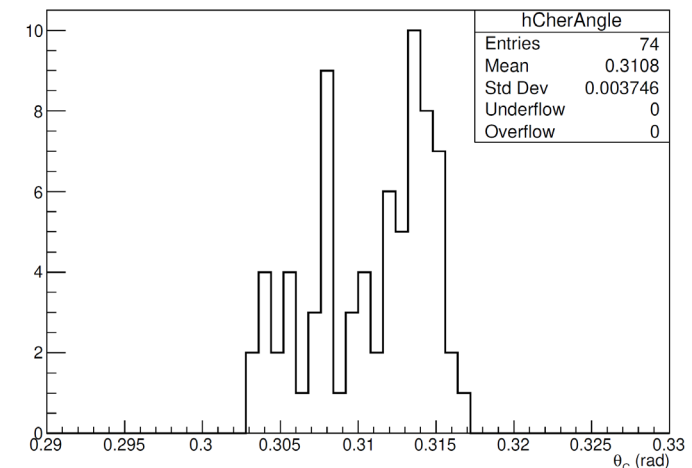

RICH element naming

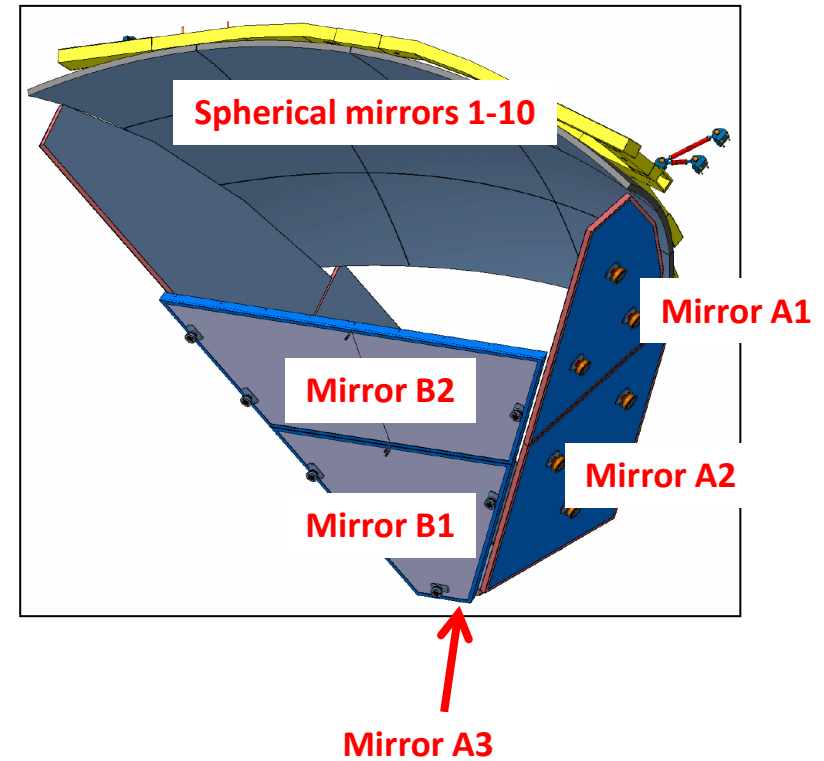
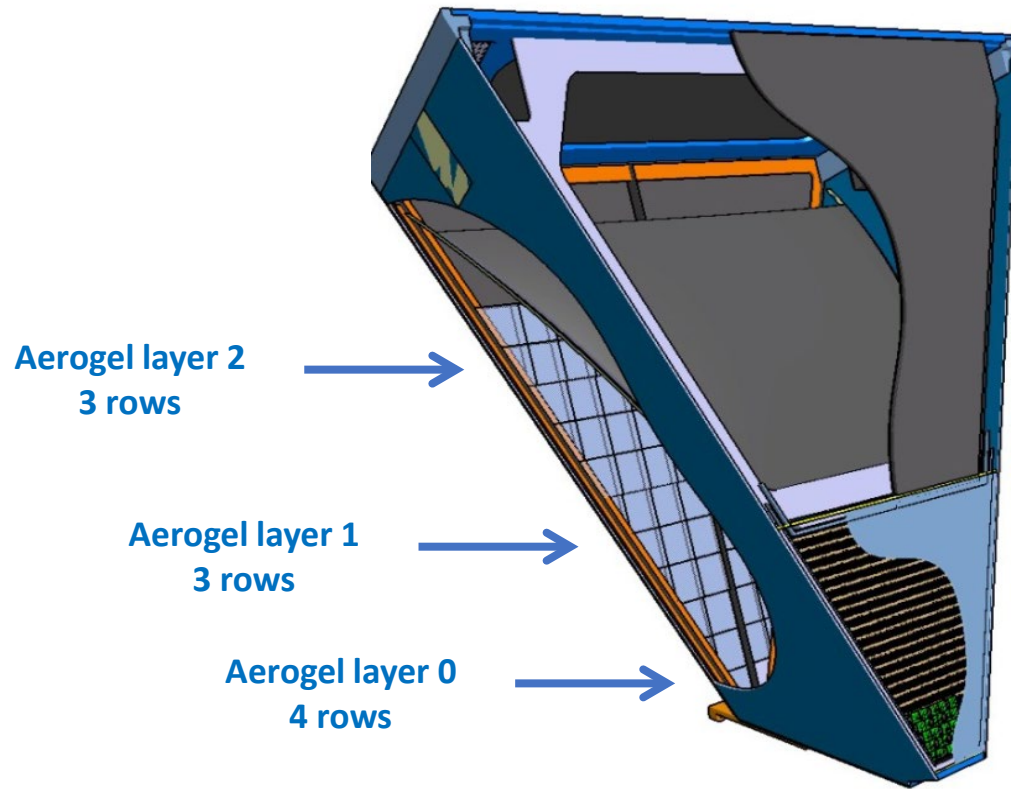

Alignment free parameters

Each element of the detector can be aligned through 6 parameters

- 3 position offsets $\Delta x, \Delta y, \Delta z$
- 3 rotation angles $\theta x, \theta y, \theta z$

Number of free parameters

- 6 for the whole RICH \rightarrow MAPMT plane 6
- 6 for each one of 3 aerogel planes 18
- 6 for each one of the 7 planar mirrors 42
- 6 for each one of the 10 spherical mirrors 60
- **Total** \rightarrow **126**

The number can be reduced by a factor of 2 because 2 offsets ($\Delta x, \Delta y$) and 1 (θz) angle do not affect (in first approximation) the measured Cherenkov angle

- Large number of free parameters
- Multiple reflections generate correlations among the mirrors

Reference numbers

- 1 mm or the shifts
- 1 mrad for the angles

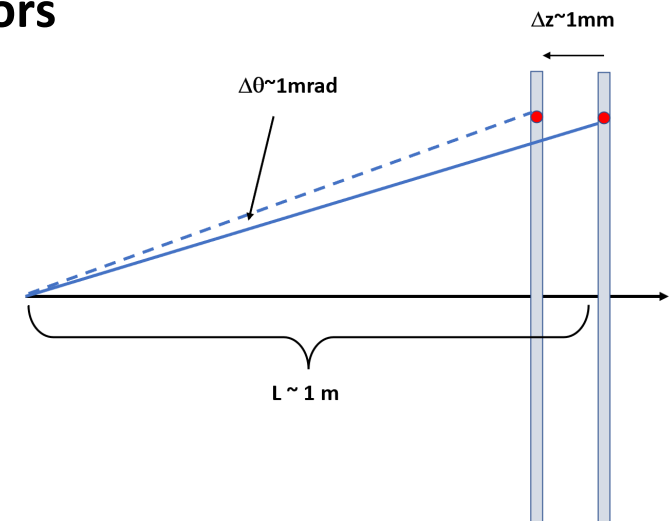

Alignment strategy

If the geometry of the RICH was perfectly known

1. the position of the track cluster must coincide with the track projection
2. all the reconstructed photons of a track must have the same Cherenkov angle, regardless of the number of reflections
3. the reconstructed angle must be consistent with the known aerogel refractive index
4. the Cherenkov angle for negative and positive particles must be the same

Alignment strategy: successive steps

1. Align the RICH (i.e. the MAPMT plane) to CLAS12 using charged tracks
2. Align the aerogel planes using direct photons (no reflections) and the known refractive index
3. Align the lateral mirror by imposing that photons with 1 reflection have the same Cherenkov angle of the direct ones
4. Align the spherical mirrors by imposing that the photons with 2 reflections have the same Cherenkov angle of the direct ones

At each step, a small sample of experimental data are reprocessed varying the alignment parameters in a uniform grid

Final check of the results:

- compare Cherenkov angles
- look at physical quantities involving kaons, like missing mass plots, etc.

Step 1: RICH alignment

- Alignment of the RICH module with respect to CLAS12 comparing the projection of the DC trajectory to the RICH MAPMT plane and the position of the track cluster
- Relative alignment between the aerogel and the MAPMT

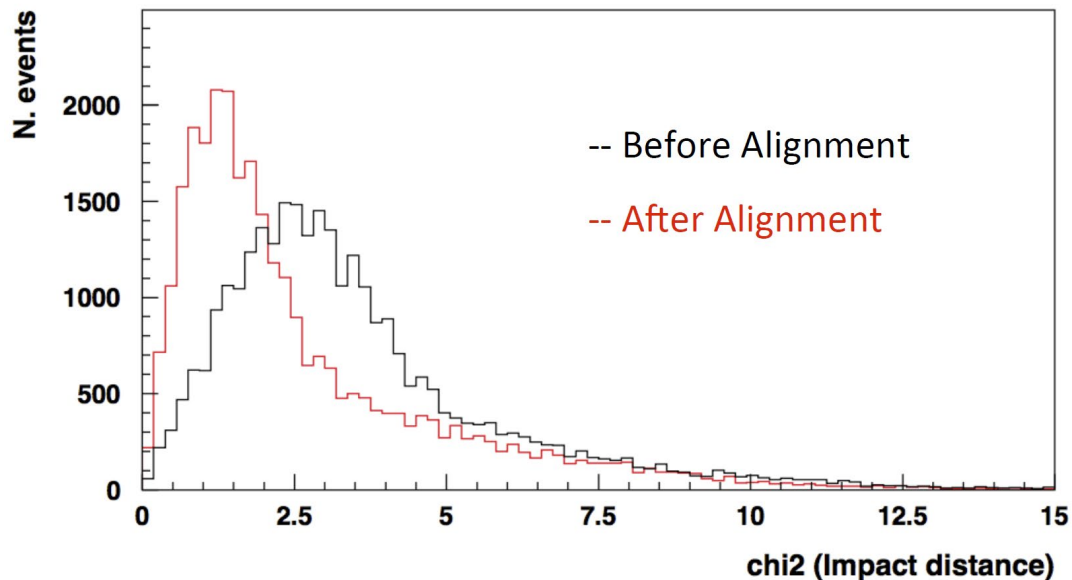
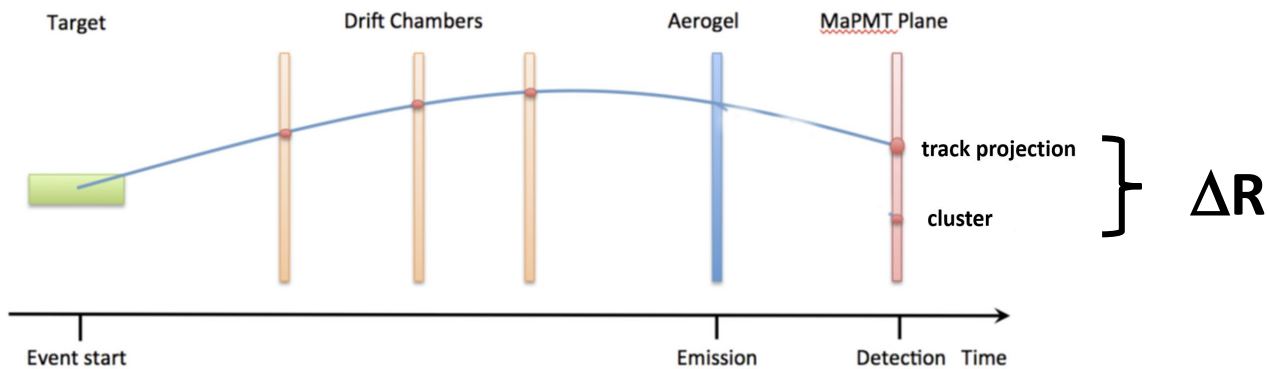

Results after alignment consistent with a pixel size of 6 mm

Cherenkov angle data analysis

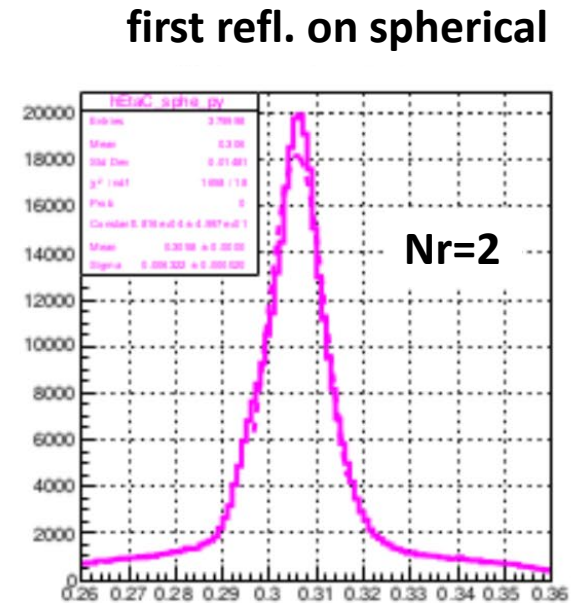
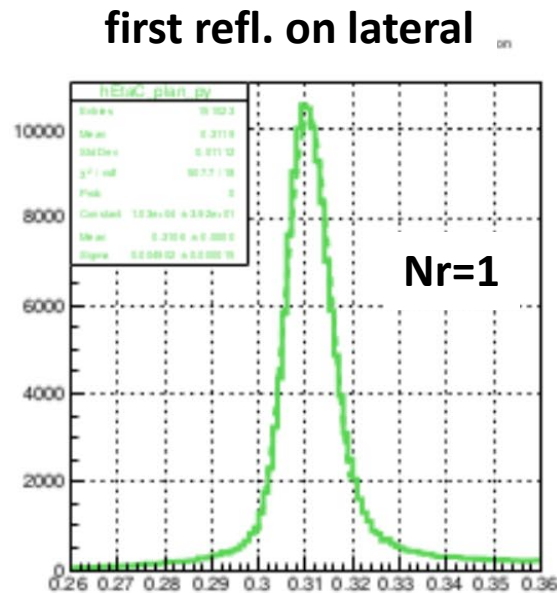
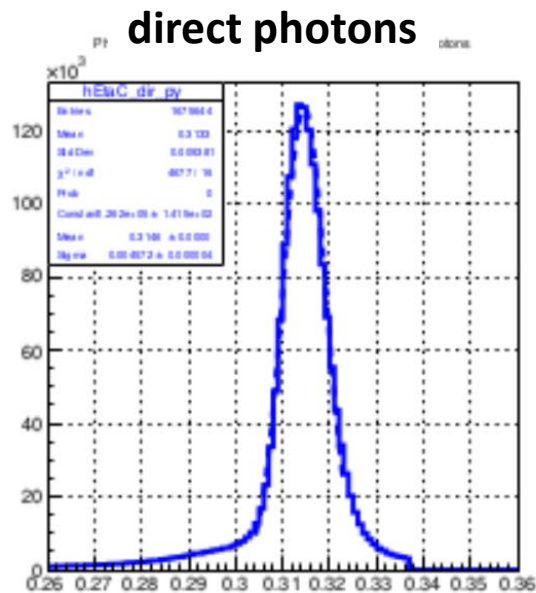

Photon 0 ($\beta=1$) vs Momentum, Layer 1, Tile 12, all planar reflections

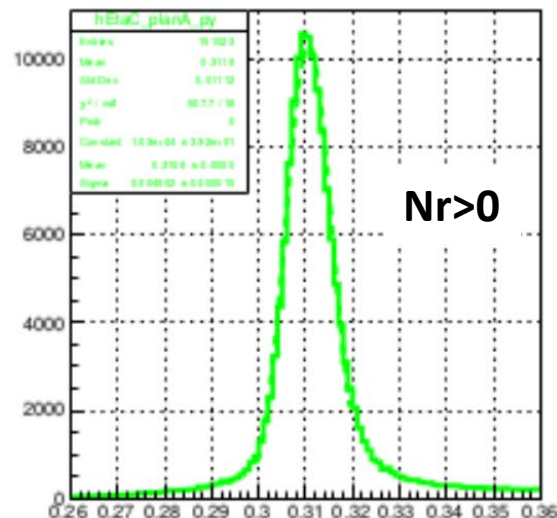

Photon 0 ($\beta=1$) vs Momentum, Layer 1, Tile 12, all spherical reflections

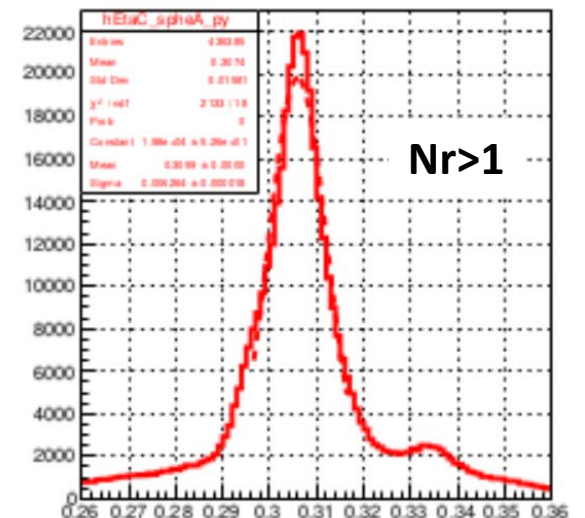

- Plots of the measured Cherenkov angle, rescaled to $\beta=1$
- One can subtract the expected Cherenkov angle and have all the plots centered to 0

Cherenkov angle alignment

- Two alignment angles θ_x, θ_y
- One position shift Δz
- Quality parameter

$$\chi^2 = \sum_{j=1}^{N_{AERO}} \sum_{i=1}^{N_{PHO}} \frac{(\theta_{i,j}^{REF} - \theta_{i,j}^{MEAS})^2}{(\sigma_{i,j}^{REF})^2}$$

- 3D scan, minimize $\Delta\chi^2 = \chi^2 - \chi^2_{\min}$ in each 1D slice

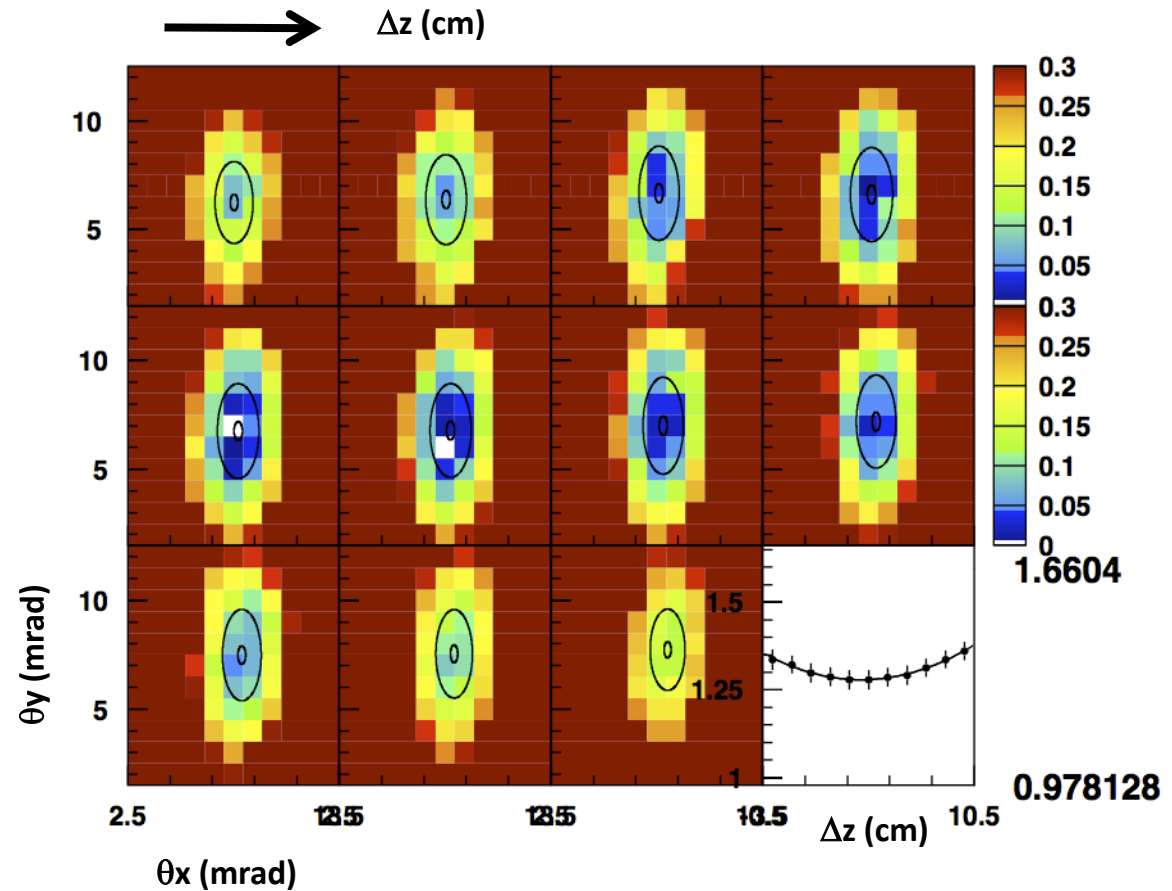

Step 2: Aerogel alignment

- Matching with Cherenkov angle computed from the known refractive index value
- Use direct photons
- Each aerogel layer is aligned separately and independently from the others
- Only 3 free parameters per layer
- No data for the large angle layer

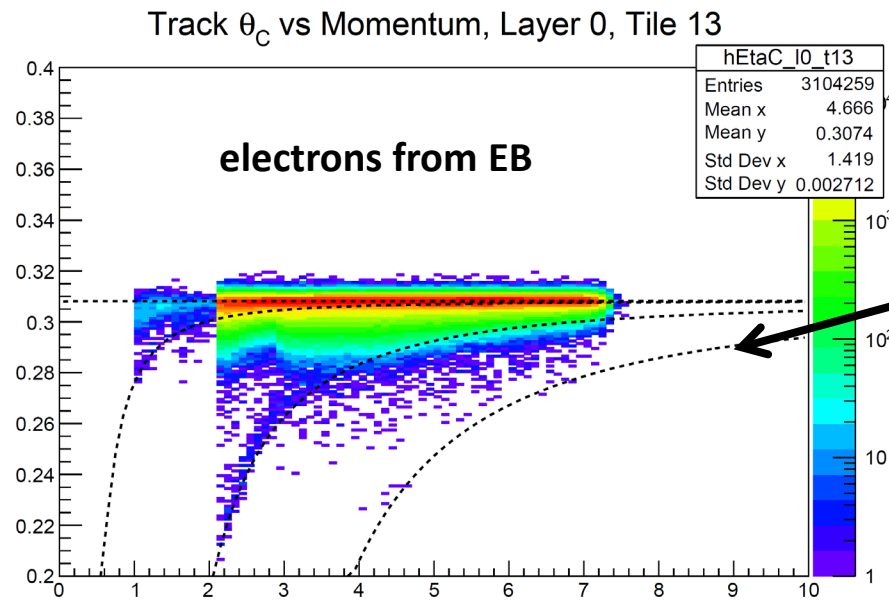
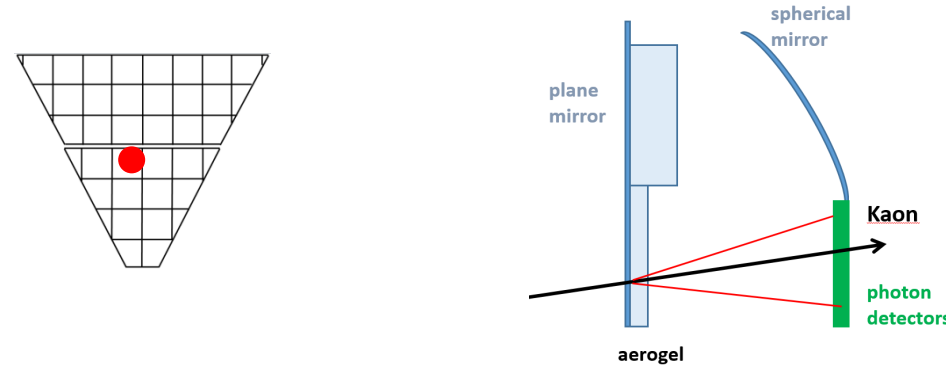

lines from the electron Cherenkov angle

Charged hadrons

- pion angle is ok
- heavier hadron angles are slightly shifted

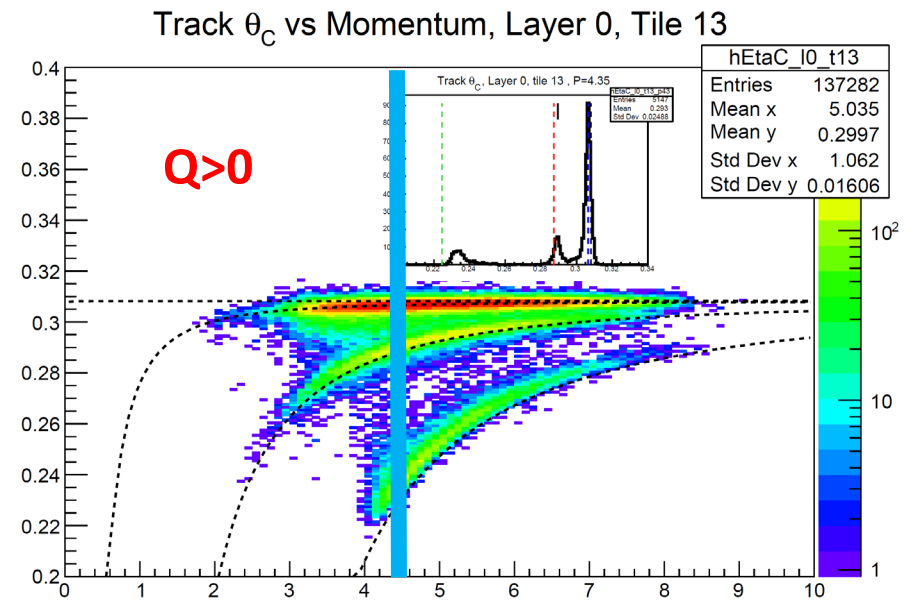

Step 3: Alignment of the lateral mirrors

- Four lateral mirrors A1 and A2 and one bottom mirror A3
- Comparing direct photons with 1 reflection photons
- Each mirror is aligned separately and independently from the others
- Small statistics for the upper mirrors A1

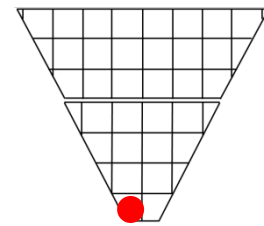
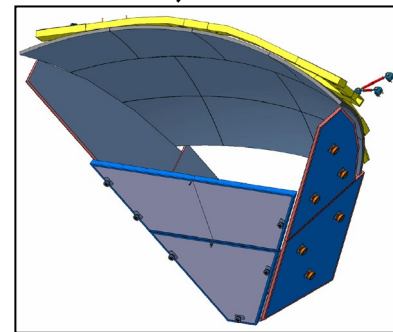
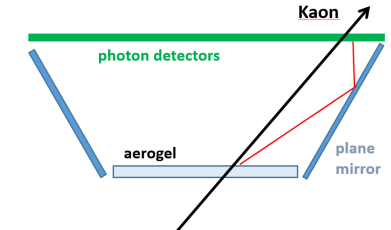

Before alignment

After alignment

Layer 0 Tile 1

Layer 0 Tile 1

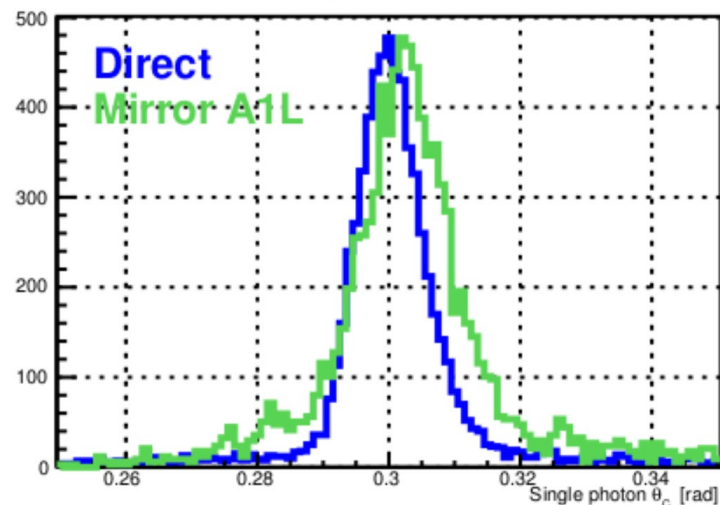
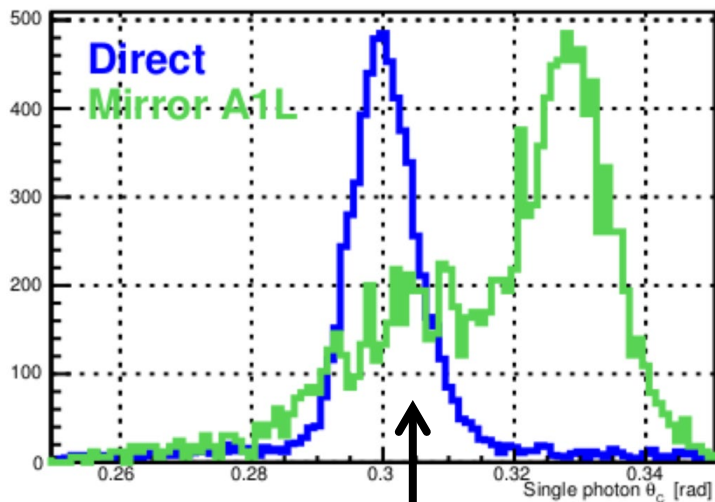

Wrong Cherenkov angle reconstruction due to misaligned geometry

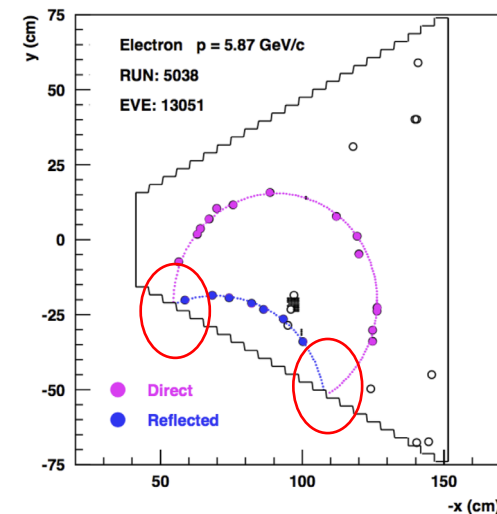

Step 4: Alignment of the spherical and frontal mirrors

- 10 spherical mirrors and 2 frontal mirrors
- Selecting photons with 2 reflection photons
- No data for direct photons in the last aerogel layer
- The frontal mirror alignment correlates the alignment of the various spherical mirrors
- Missing information on the second reflection in the data

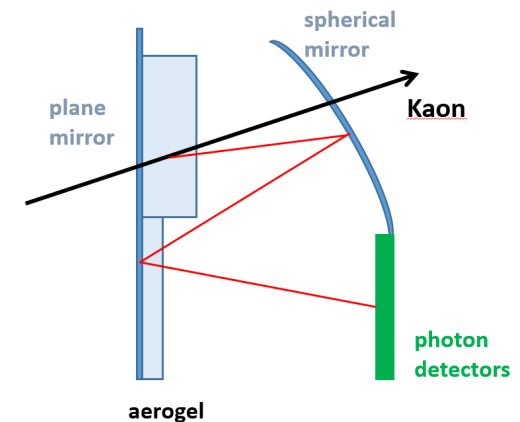
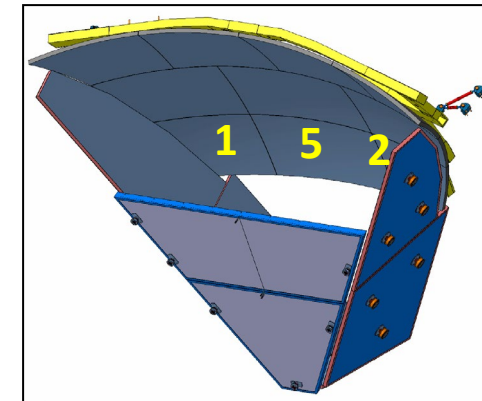
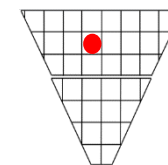
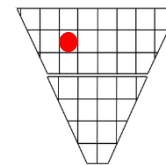
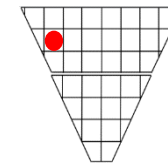
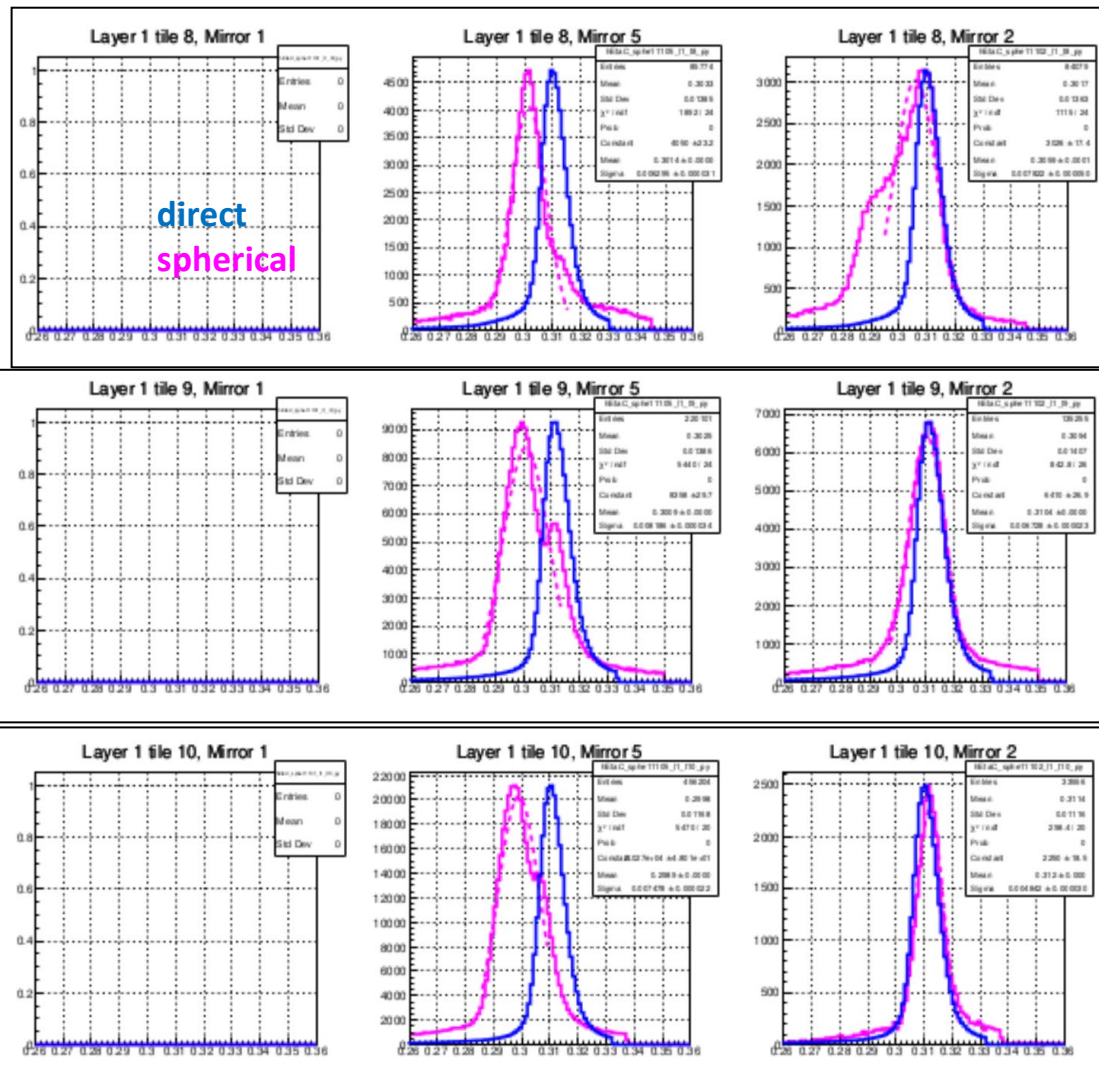

Alignment results

Mean Cherenkov angle per aerogel tile

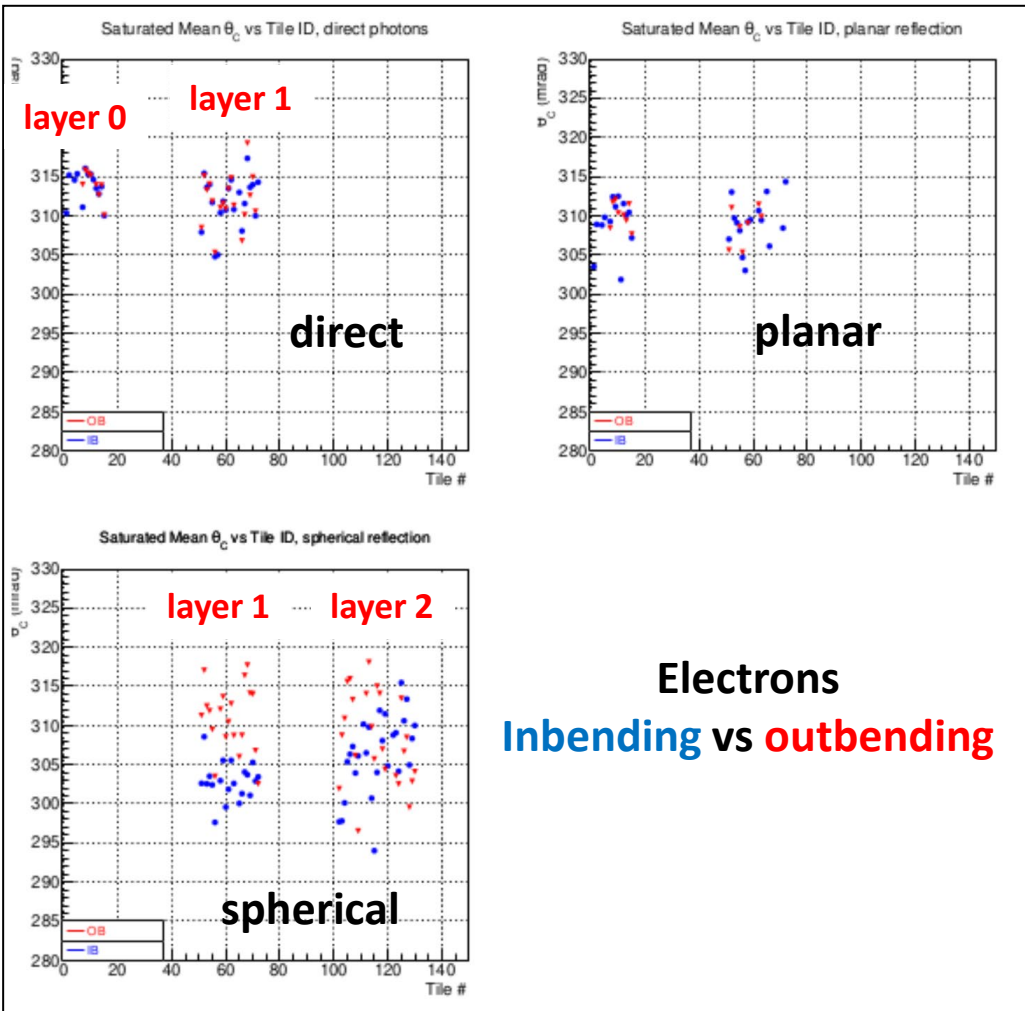

Electrons
Inbending vs outbending

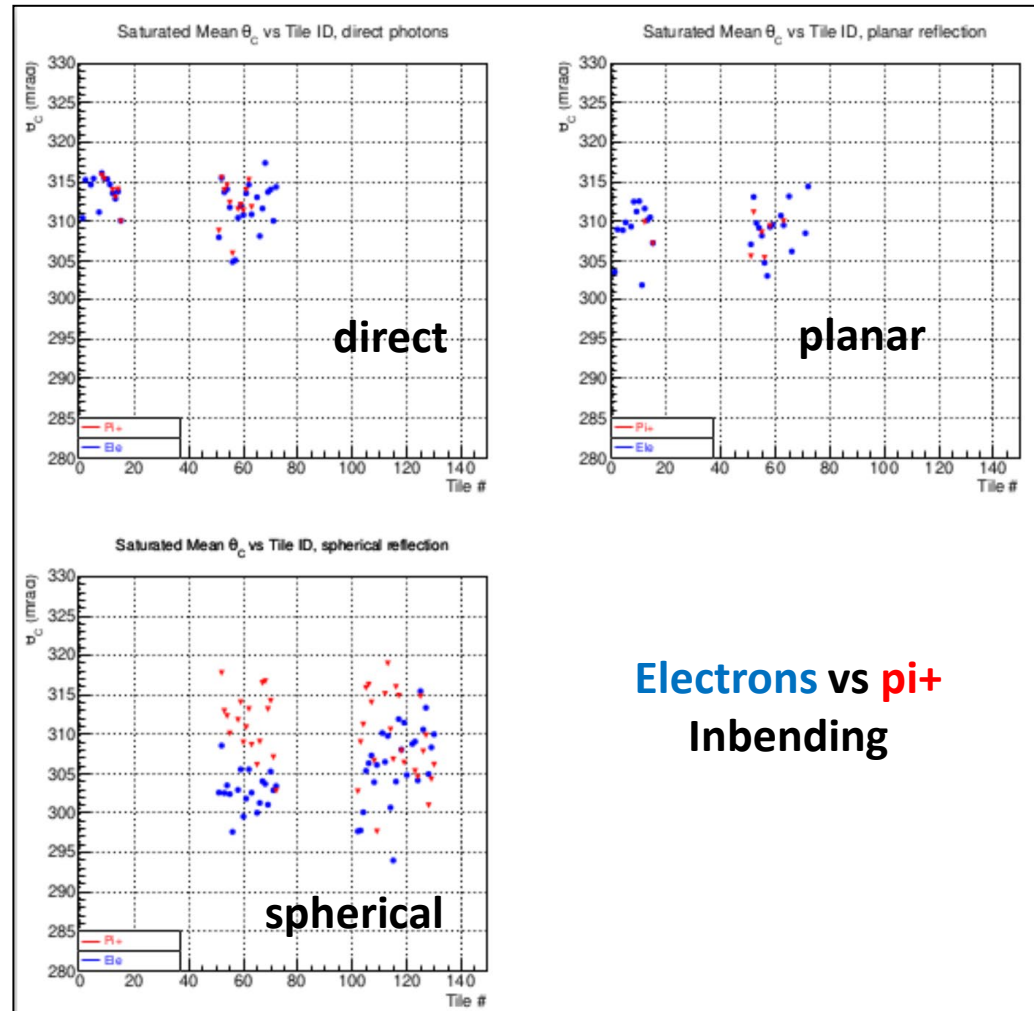

Electrons vs π^+
Inbending

PID performance

Selecting events $e p \rightarrow e K^+ X$ and looking at the missing mass

- X can be Λ , Σ^0 , ... but not a nucleon

RICH ID using photons with Nrefl=0,1

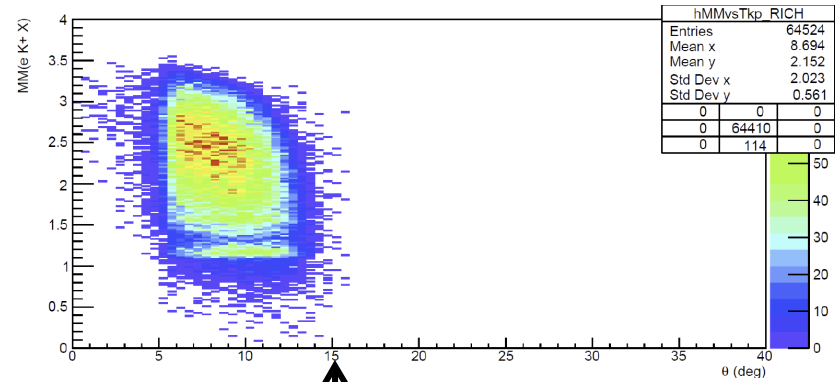
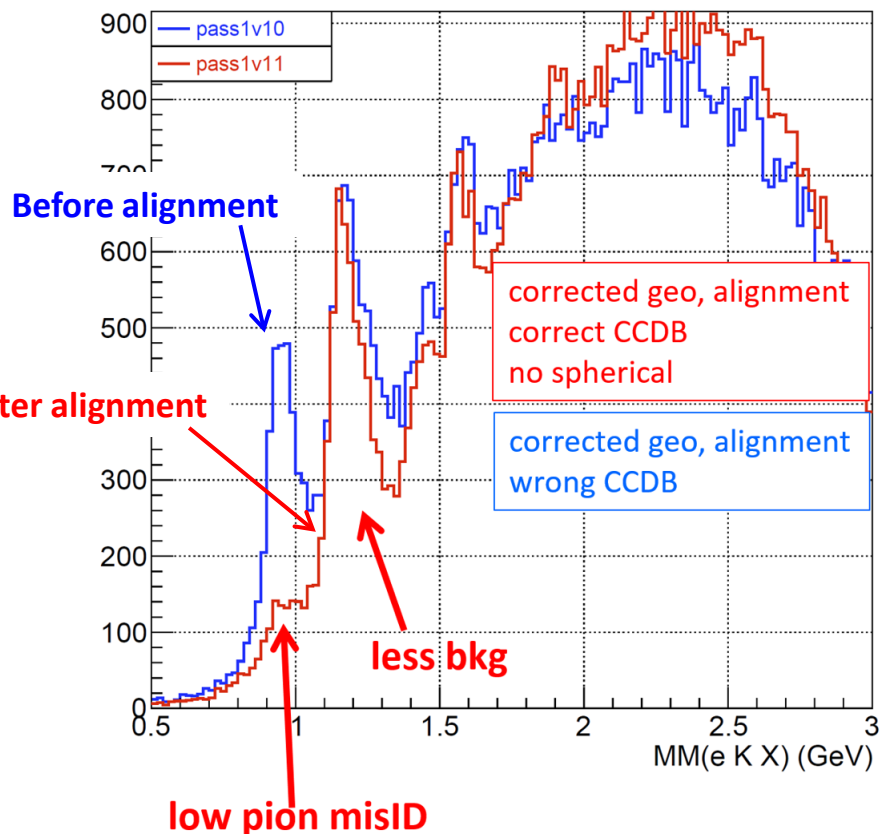

Kinematic acceptance limited at 15 deg

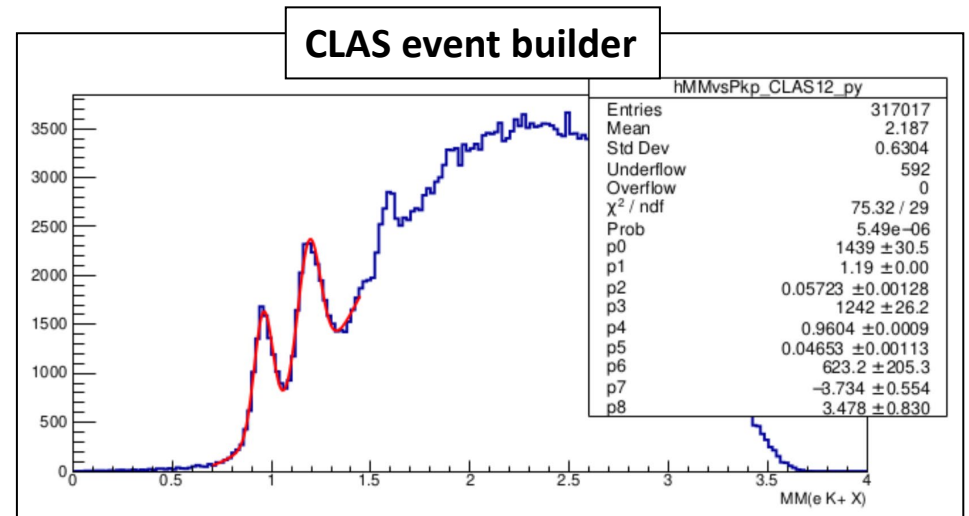

Improving the aerogel alignment

Map of the difference between the measured and the reference Cherenkov angle (direct photons)

- Up to few mrad residual difference, mostly negative
- Forward tiles better than larger angle ones

Wrong gap length?

Wrong reference refractive index?

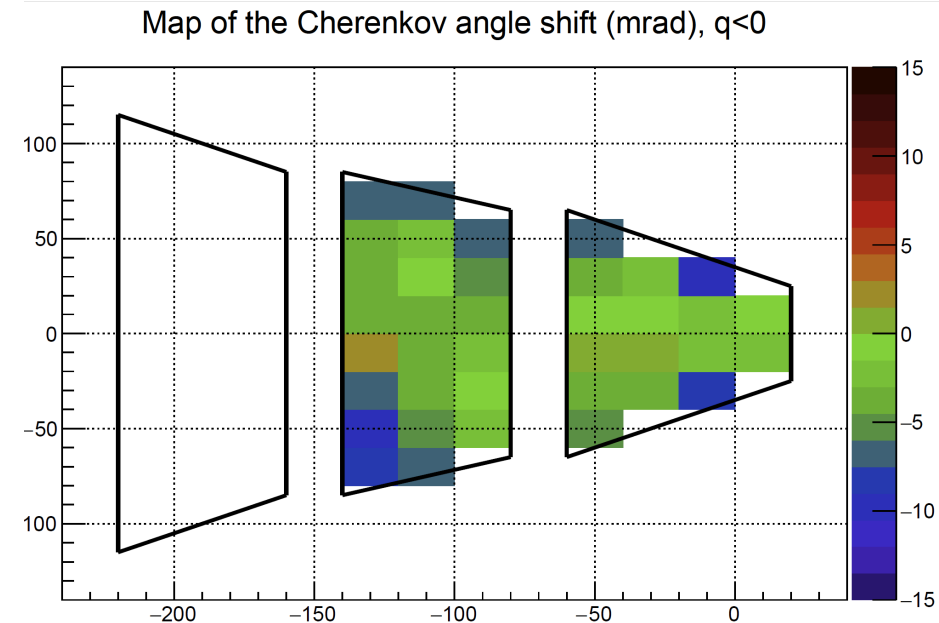

**The alignment procedure used so far assumes the aerogel refractive index known
Can it be extracted from the data together with the gap length?**

Ray tracing of direct photons can be solved analytically

- For a photon γ produced by a track j , the radius is given by:

$$R_\gamma = (t_{rad} - L_\gamma)f_1(n; \gamma, j) + t_{gap}f_2(n; \gamma, j)$$

- Selecting electrons and heavier particles (eg protons) one has 2 equations and 2 unknowns

Correlation studies

Fast simulation:

real electron tracks from RGA data, simulated photons in a simplified RICH geometry

Photon hit counts per aerogel tile

total number of photons

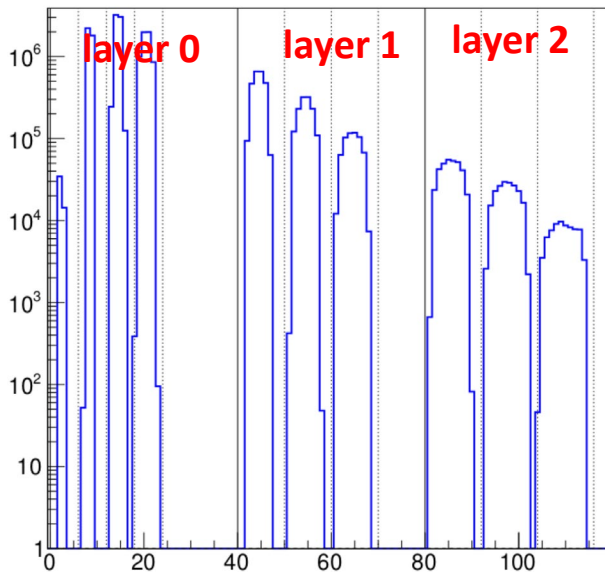

fraction of photons
on the spherical mirror

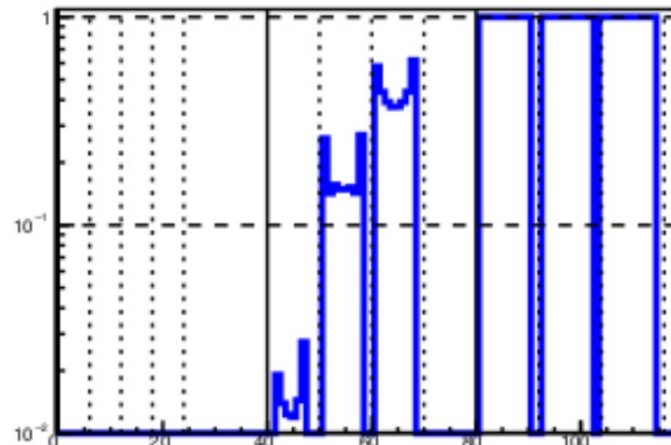

fraction of photons
on the frontal mirror B1

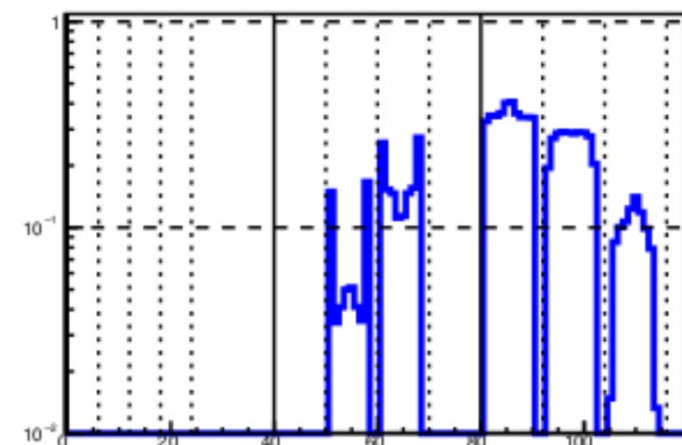

The lower part of the detector (aerogel layer B1, lower later mirrors) seems to be relatively uncorrelated to the upper part

The alignment process can be split (at least) in two part

- align aerogel layer 0, flat mirrors A3, A2L, A2R (and perhaps A1L, A2L): 12 (or 18) free parameters
- align aerogel layer 1 and 2, the frontal mirrors, the spherical mirrors: 42 free parameters

Summary and outlook from the present alignment

- **The sequential alignment procedure used so far worked satisfactorily for simple topologies**
 - **direct photons**
 - **1 reflections**
- **Residual discrepancies among positive and negative particles (or inbending and outbending data) survive, however they can be accounted for in the CCDB**
- **The alignment is not satisfactory for more complicated topologies, in particular when spherical mirrors are involved**

The problem is that the method cannot take into account correlations among the various elements

- **part of the necessary information is missing, will be available in the next reconstruction software release**

We are now investigating a different approach, based on the Machine Learning, looking for alignment of several elements at the same time and combining together results from all the possible topologies