

El Observatorio Pierre Auger y la Cooperación Argentina-Italia en Astrofísica



**Universidad de San Martín,
Buenos Aires**



The first large physics internacional project in Argentina

Observatorio Pierre Auger, Mendoza

1992 J. Cronin & A. Watson suggest building a giant array
1995 Design report + collaboration formation + site selection



1999 1st Signature of International Agreement
2001 PAO Engineering Array (EA) operated for 6 months
2006 AMIGA + HEAT approved by the collaboration



2008 End of PAO construction, start of phase-1 data



The Pierre Auger Observatory established a new paradigm in the field of UHECR

2015 2nd Signature of International Agreement & AugerPrime



The first large physics internacional project in Argentina

Observatorio Pierre Auger, Mendoza

1992 J. Cronin & A. Watson suggest building a giant array
1995 Design report + collaboration formation + site selection



1999 1st Signature of International Agreement
2001 PAO Engineering Array (EA) operated for 6 months
2006 AMIGA + HEAT approved by the collaboration



More than 20 year of an extremely successful story for international science!
Argentina & Italy played a major role during all these years

2008 End of P

The Pierre Auger Observatory
established a new paradigm in the
field of UHECR



2015 2nd Signature of International Agreement & AugerPrime



The Pierre Auger Observatory

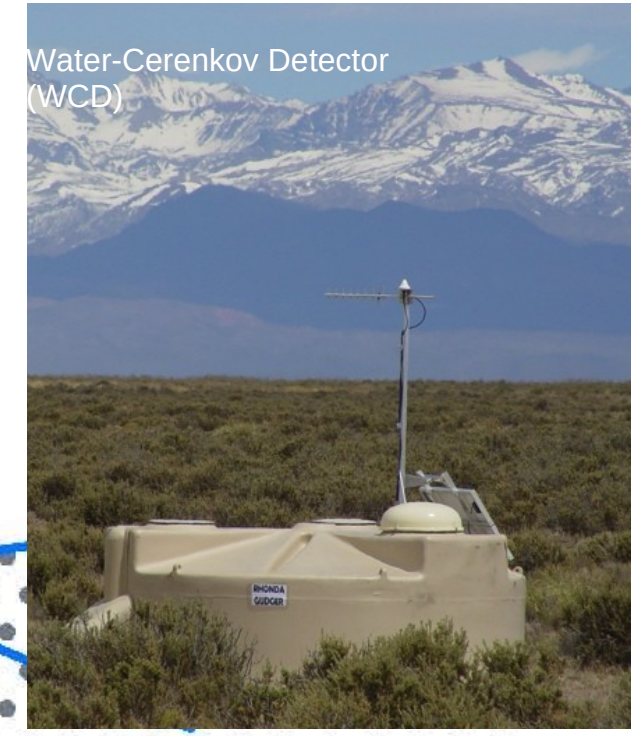

Surface detector (SD)

100% duty cycle

<p>SD-1500m 3000 km² 1600 WCDs</p> <p>E_{thr}^v 2.5 EeV E_{thr}^i 4.0 EeV</p>	<p>SD-750m 23.5 km² 61 WCDs</p> <p>E_{thr} 0.1 EeV</p>	<p>SD-433m 1.9 km² 19 WCDs</p> <p>E_{thr} 0.03 EeV</p>
---	--	--

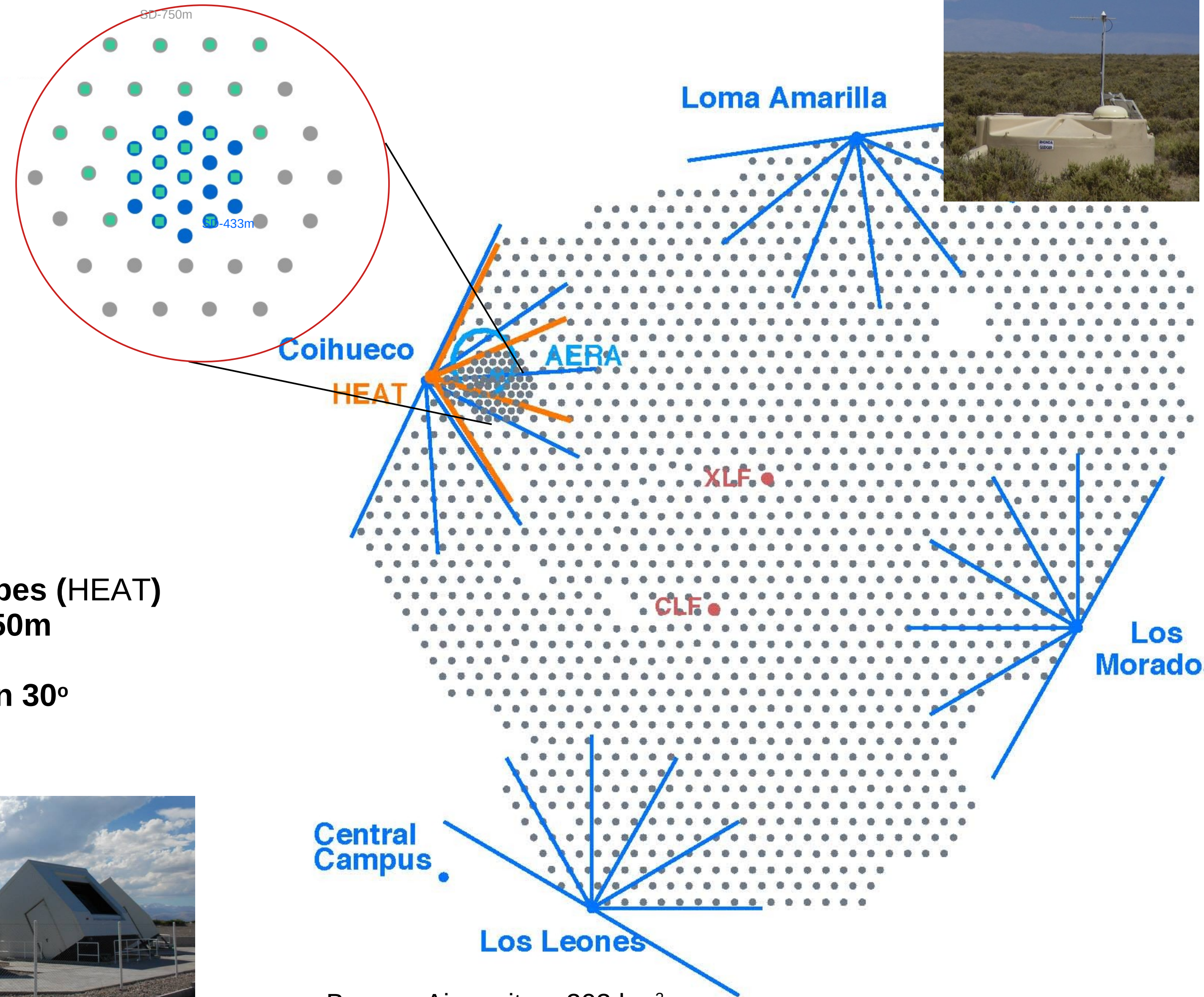

Fluorescence detector (FD)

15% duty cycle

4 units x 6 telescopes
 overlooking SD-1500m
 FoV 30° x 30°
 Minimum elevation 1.5°

1 units x 3 telescopes (HEAT)
 overlooking SD-750m
 FoV 30° x 30°
 Minimum elevation 30°



Central Campus

Los Leones

Buenos Aires city ~ 203 km²
 Turin city ~ 130 km²

The Pierre Auger Observatory

Underground Muon detector (UMD)

100% duty cycle



UMD-750m
23.5 km²
61 WCDs
 E_{thr} 0.1 EeV

UMD-433m
1.9 km²
19 WCDs
 E_{thr} 0.03 EeV

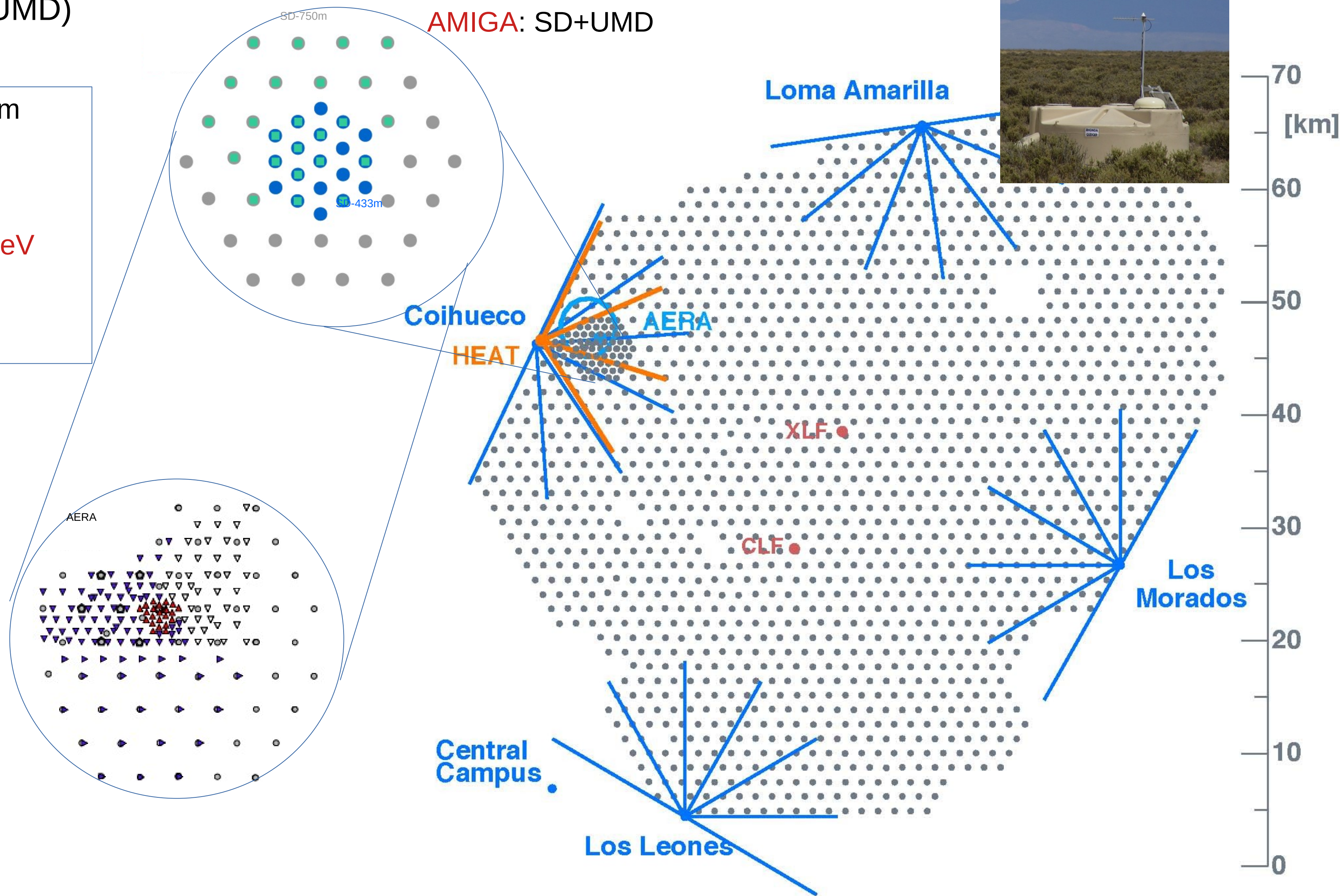
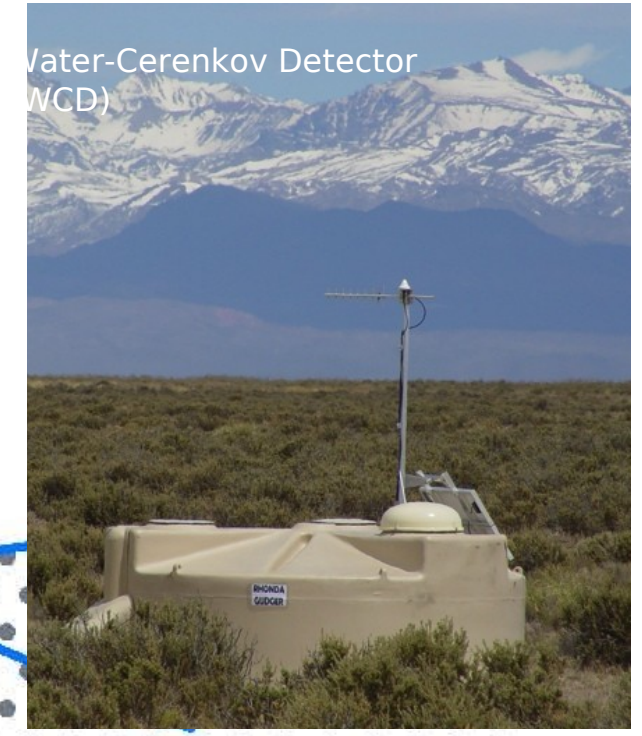

Radio detector (AERA)

100% duty cycle

30-80 MHz
153 radio stations over 17 km²
Spacing from 150m to 750m



Buenos Aires - Torino collaboration within Auger



AMIGA-UMD produced in Torino during Engineering Array phase

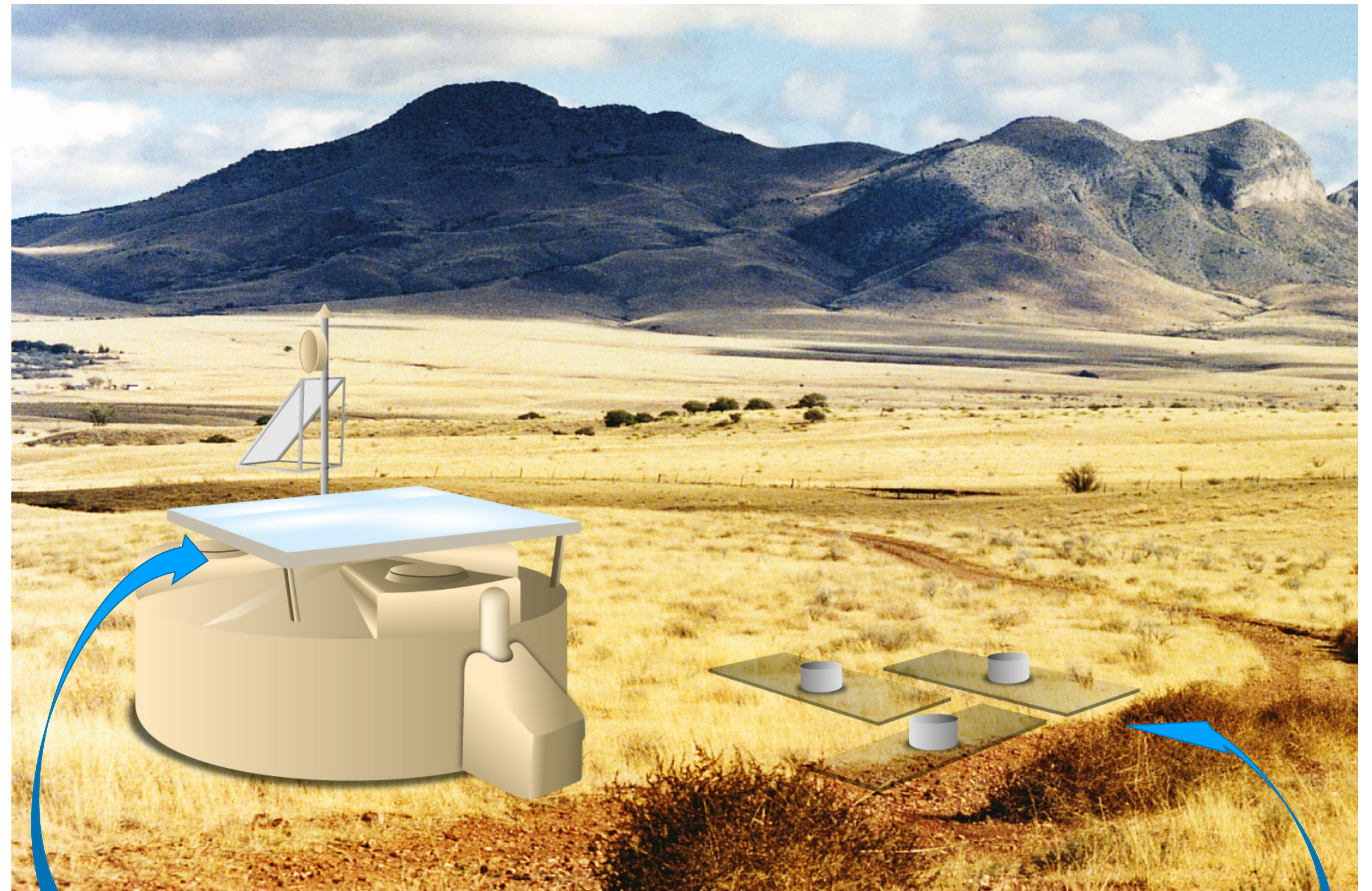
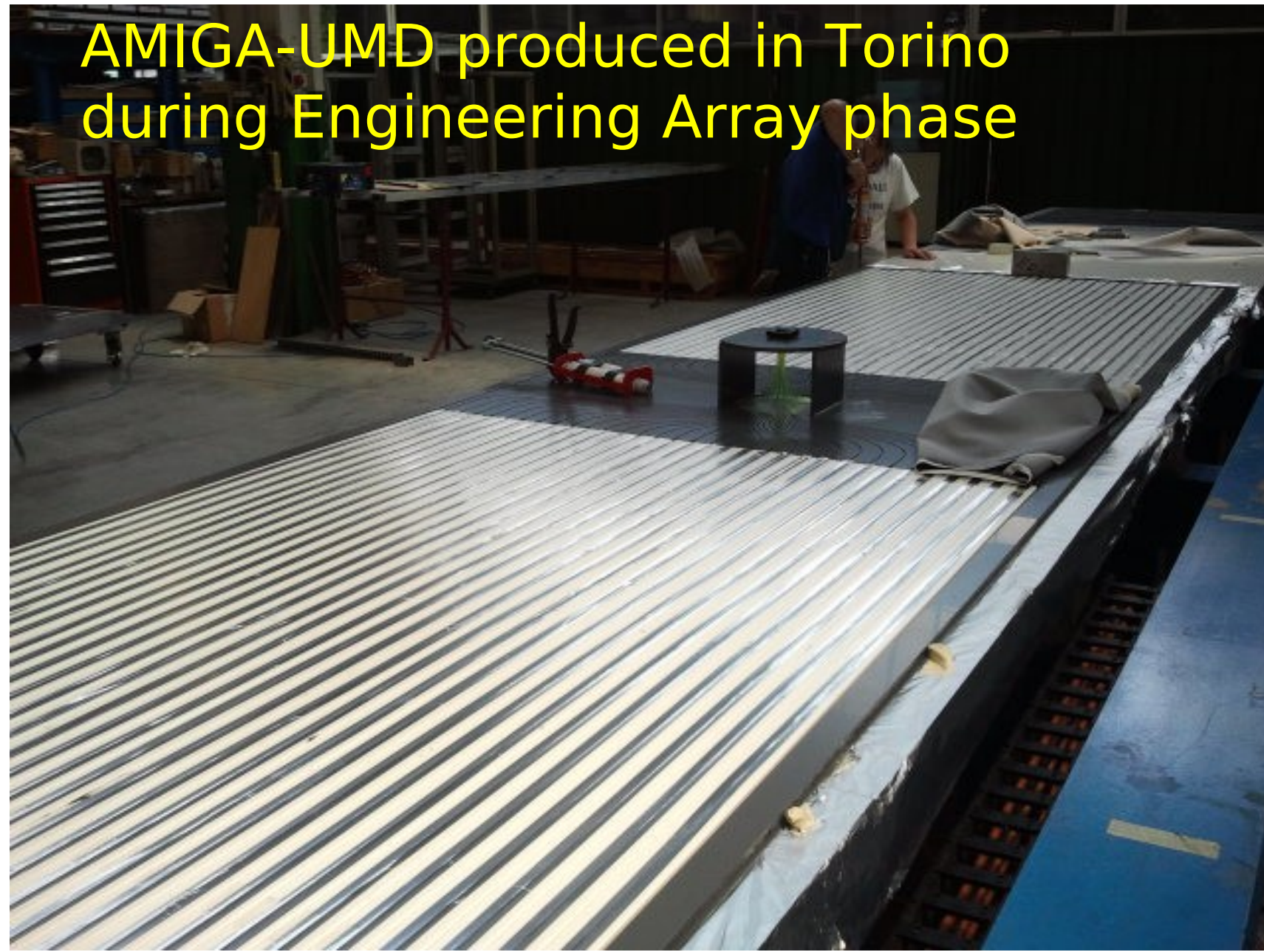

Leading roles in:

Surface Scintillator Detectors

Underground Muon Detectors

Twin analysis & detector efficiency studies

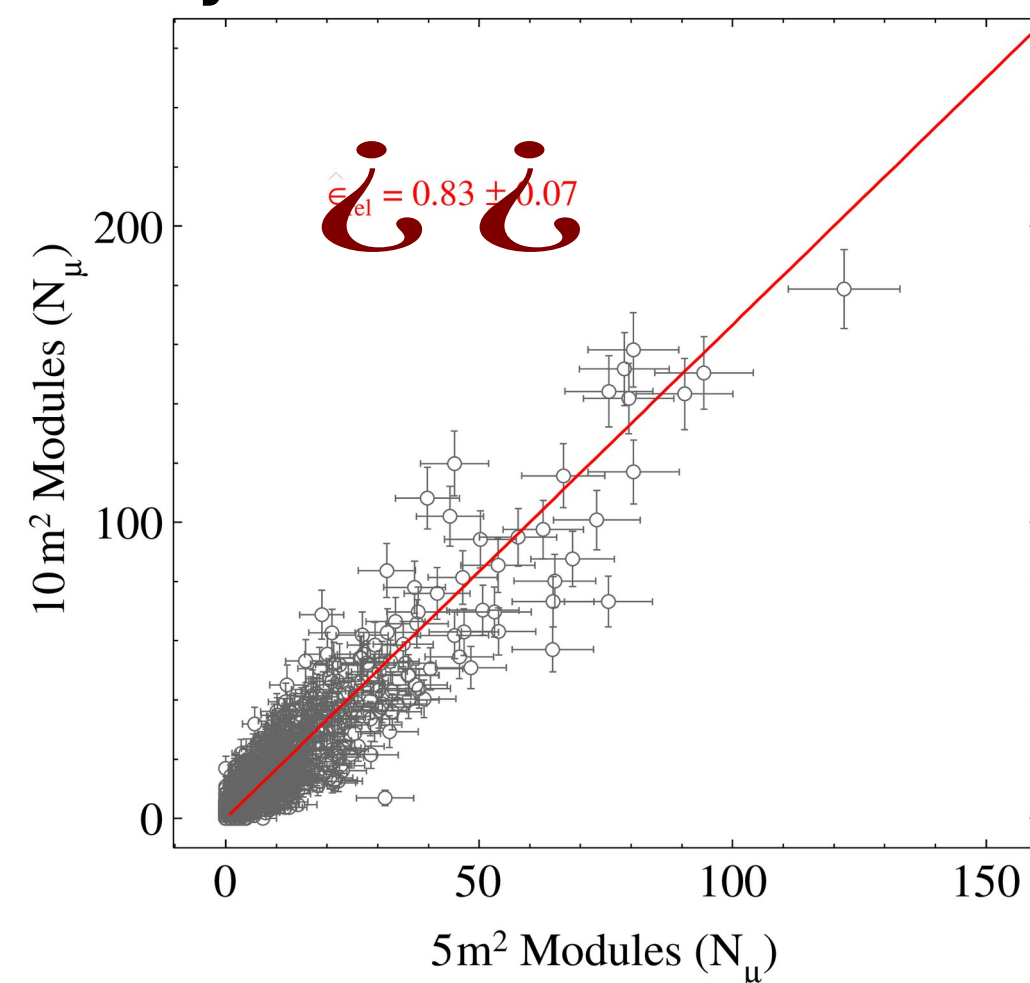

The Pierre Auger Observatory legacy

The Pierre Auger Observatory demonstrated how big science be performed in Argentina if there exists a strong commitment of world-wide collaboration

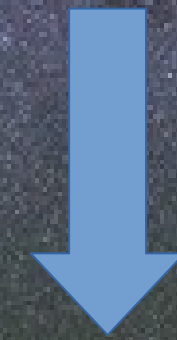

New projects:

1. QUBIC
2. ANDES

Based on Auger developed Management, Administration, Scientists and Technicians. Largely based in CONICET personal working in CNEA

New projects with Argentina-Italy commitment (hosted in Arg.)

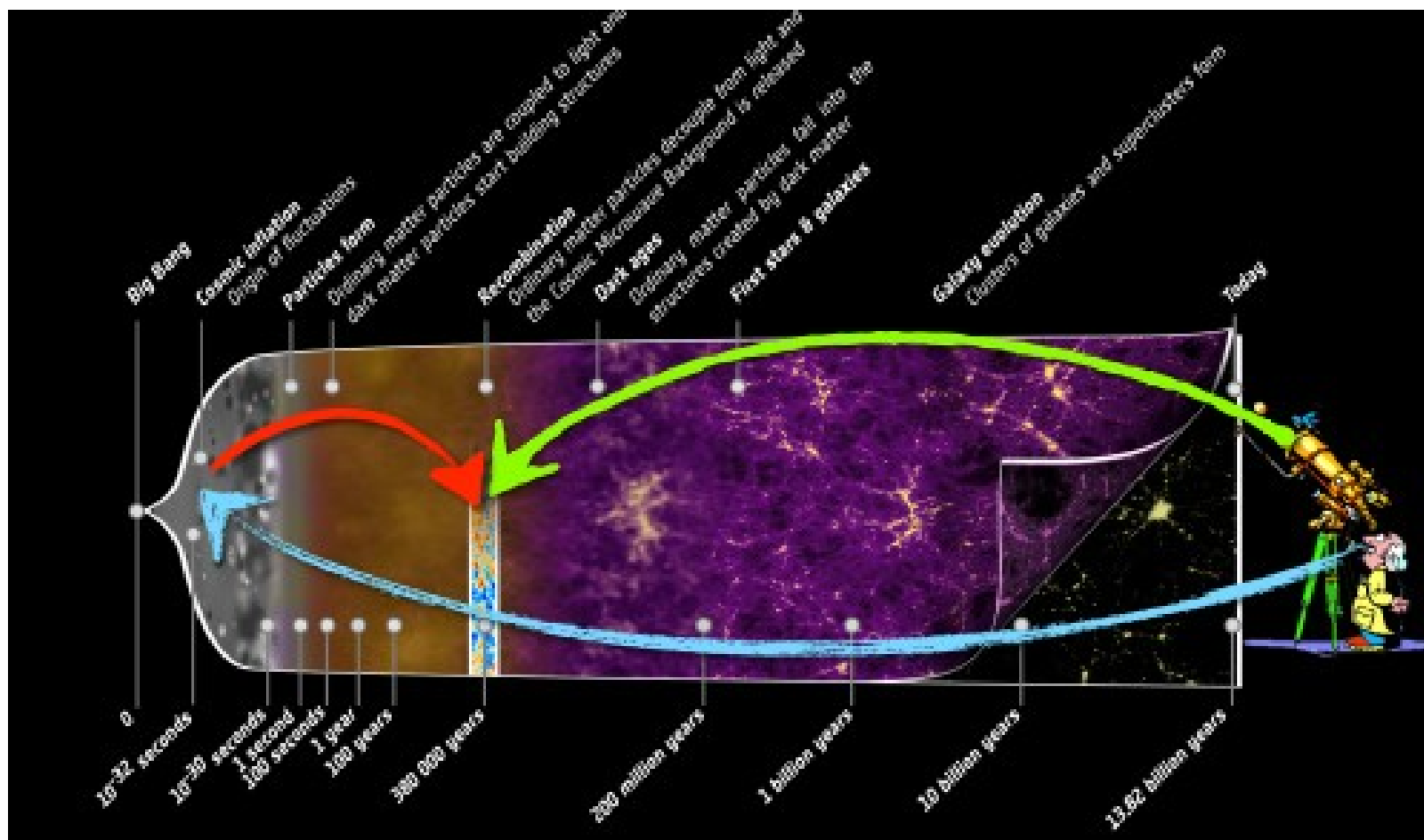

1.- QUBIC Observatory, Salta

2.- Underground Laboratory ANDES, San Juan/Argentina - Reg. IV/Chile

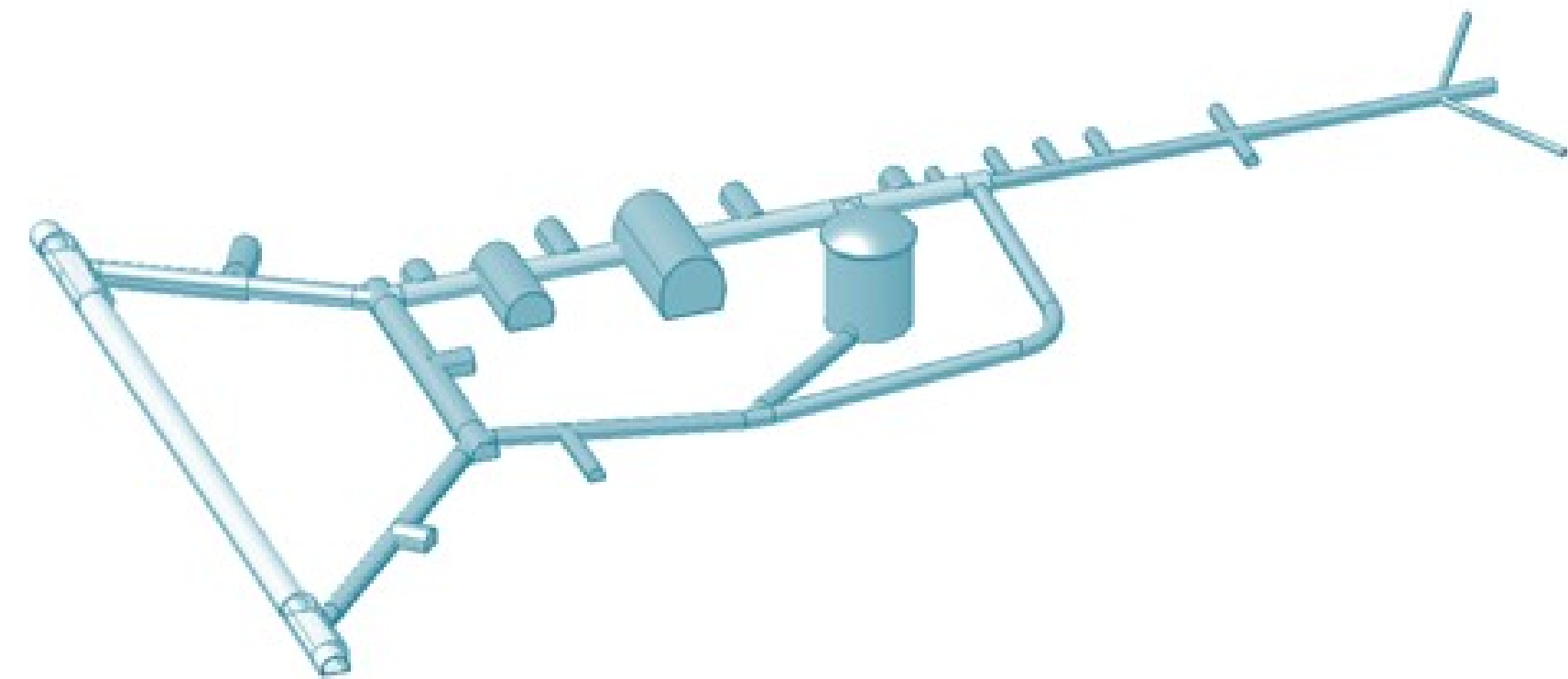

QUBIC Observatory

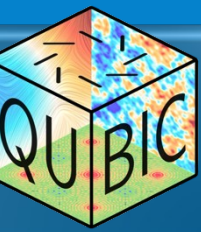

The QUBIC International Observatory will detect cosmic microwave background radiation (CMBR) which contains information on the primordial gravitational waves of the early universe (10^{-32} seconds after the Big Bang, the time of universal inflation). The first detection module will be installed in Altos Chorillo, Salta in November 2022.

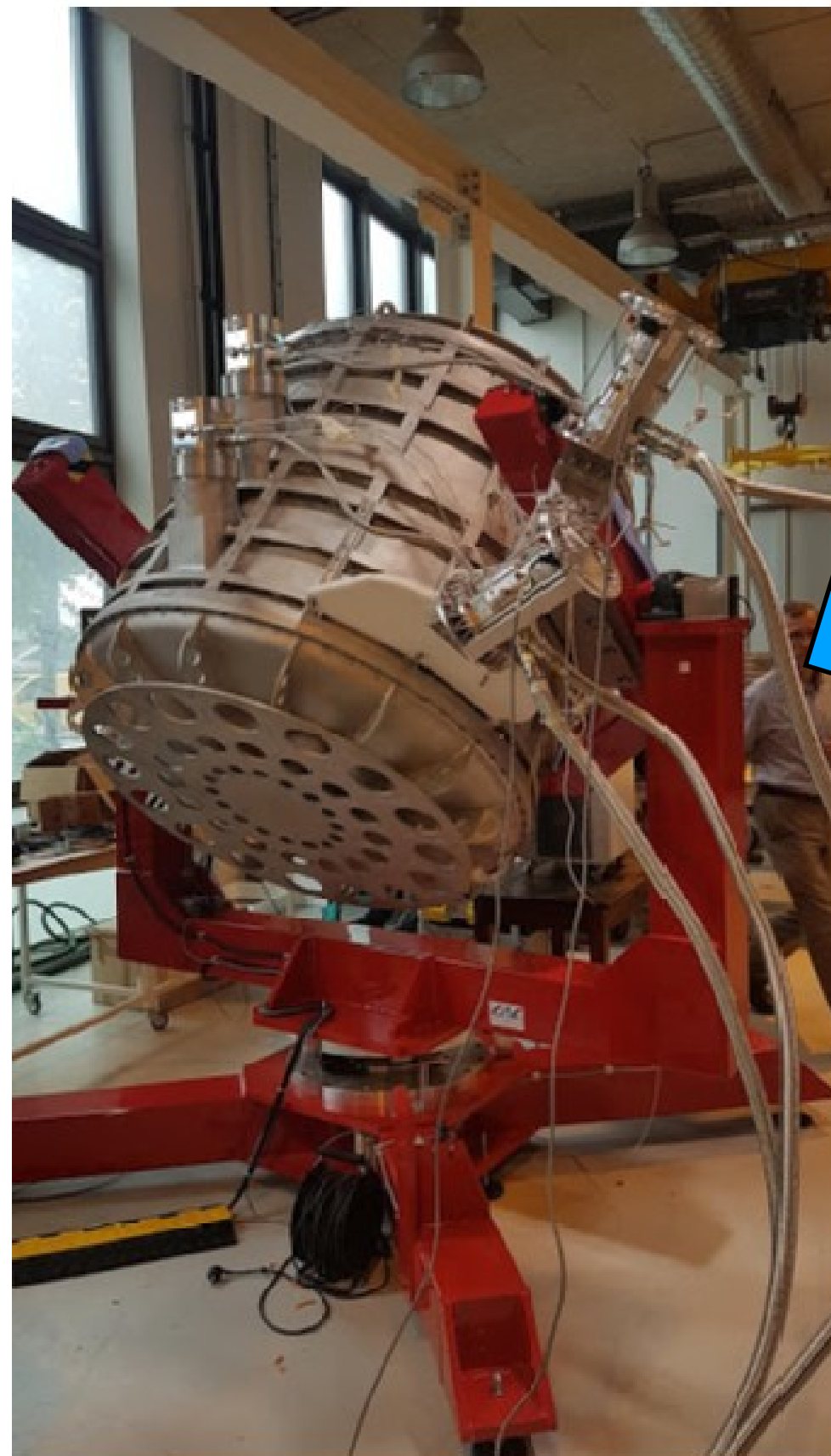

First Telescope

Originally assembled at La Sapienza University-Rome
and sent to APC-Paris.
Now in the laboratory of Integration in Salta

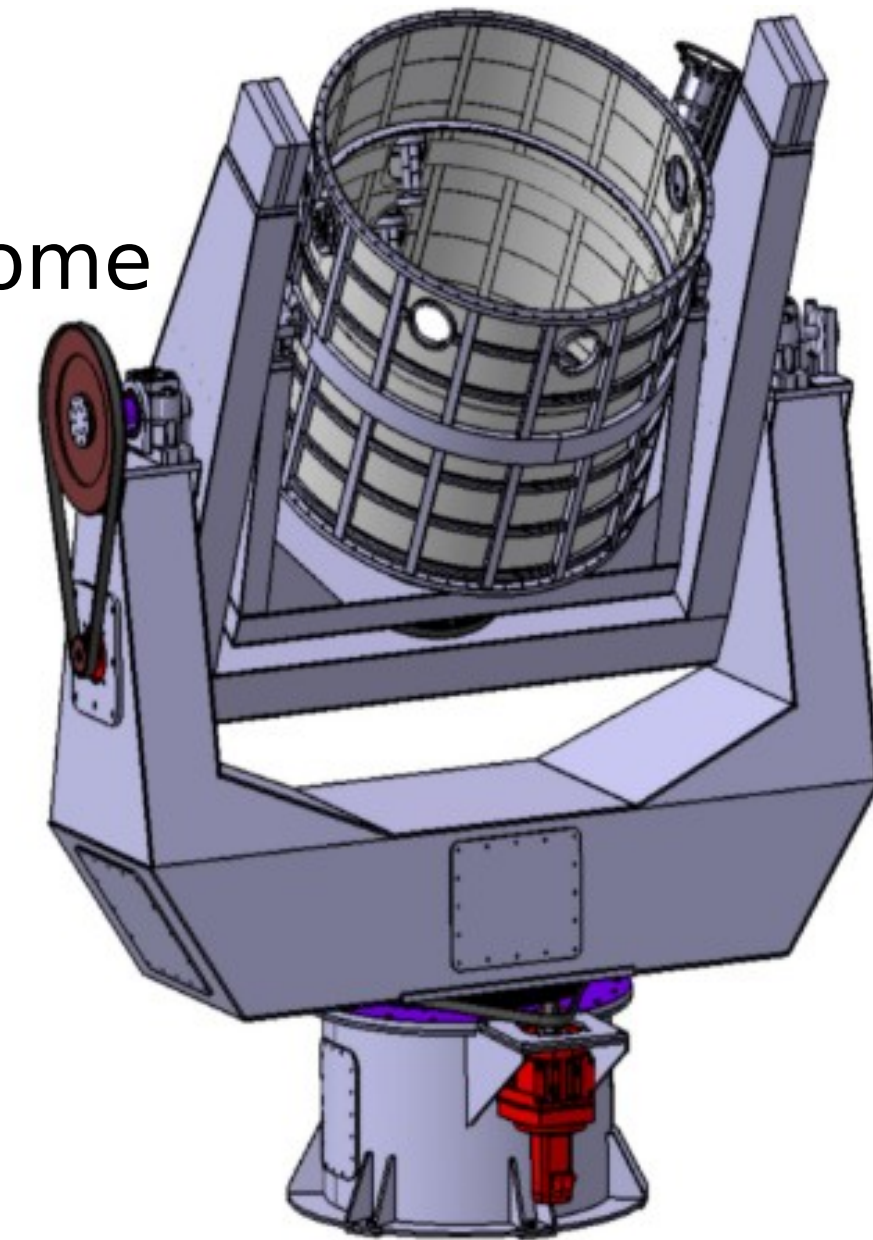

Telescope mount, designed and already built in Argentina
Accuracy 0.01°

INTERNACIONAL COLLABORATION
Argentina, Francia, Italia, Ireland,
United Kingdom, United States

2021: Telescope Shelter

Telescope shelter. Structure designed by ITeDA Mendoza in Regional CNEA-Mendoza.

Based on the LIDAR shelter of the Auger Observatory

Revised by Dept. Technology of Composite Materials- GDTPE

Under construction, to be inaugurated in Nov 2022

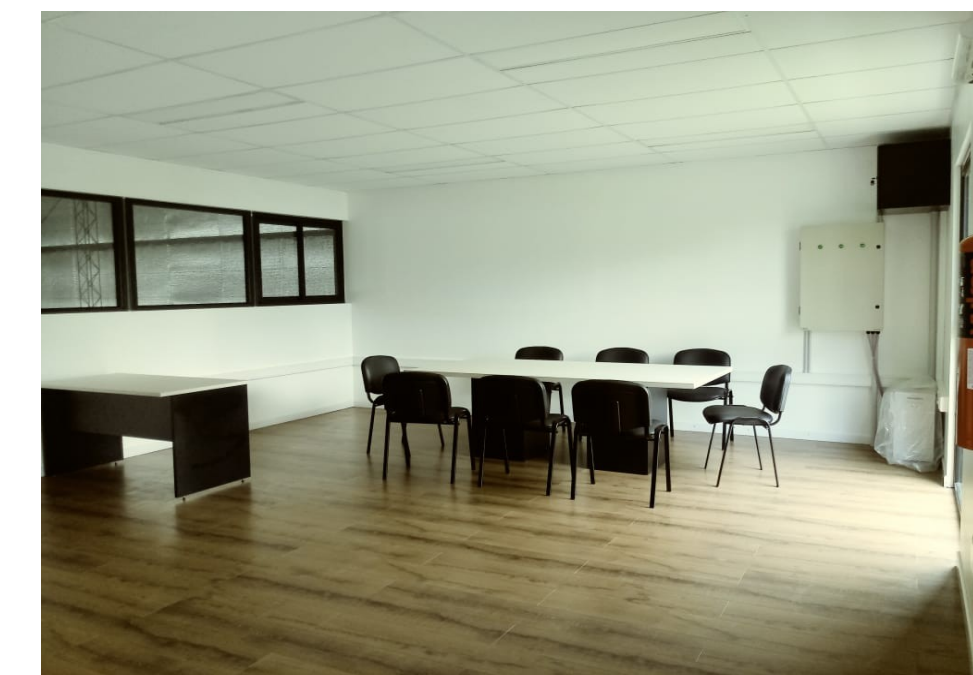
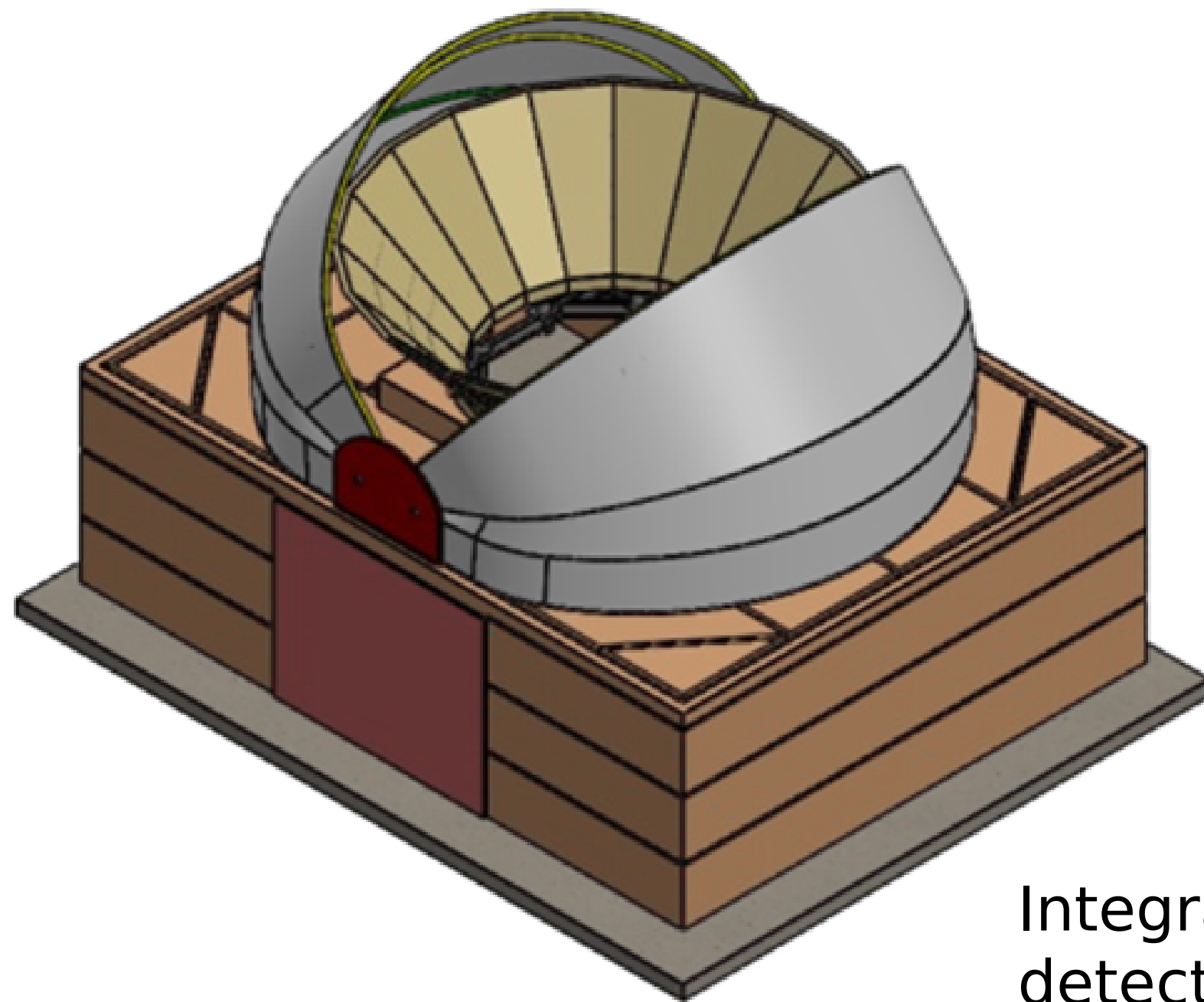

Integration Laboratory in the Regional NorOeste- CNEA, Salta (330 m²) All detection systems are and will be integrated here before transferring them to the Observatory

Design and construction of the Integration Laboratory and construction of the telescope shelter by the Technical Assistance Department Technical - CNEA- Córdoba - GEMP

October 2021: Integration Laboratory Inauguration @ RNO-CNEA



- Tasks performed in Argentina:
- i) Site Development,
 - ii) Microfabrication,
 - iii) Electronics,
 - iv) Bolometer mount,
 - v) Assembly, testing and calibration of measurement systems
 - vi) Simulations and data analysis
 - vii) Customs and transportation

Integration Laboratory Inauguration QUBIC – Ciudad Salta

Sr. Ministro de Ciencia, Tecnología e Innovación de la Nación, Lic. Daniel Filmus,

Sr. Ministro de Educación, Cultura, Ciencia y Tecnología de la Provincia de Salta, Mag. Matias Canepa,

Sra. Presidenta de CNEA, Dra Adriana Serquis

Sra. Presidenta del CONICET, Dra. Ana Franchi,



Descubriendo Placa Recordatoria

ANDES Laboratory

Agua Negra Deep Experiment Site



At 1,700 m below the earth's surface, only a few particles are capable of penetrating the rocky layers, allowing them to be studied, without interference and with great precision (neutrinos, dark matter -80% matter in the universe).

ANDES Laboratory: El Túnel de Agua Negra



Biocean Corridor for Regional Integration

Commercial port in the Pacific ocean for Asia (China, India, Japan, ...)

1.700 m rock (shielding)

ANDES Laboratory (40 MUSD)
Túnel de Agua Negra San Juan - Coquimbo en Chile - Argentina and Chile), 1.500 MUSD, IDB fund approved

ANDES Laboratory

1) Astrophysics

1.1) Neutrino physics:

- Double Beta Decay (Dirac vs. Majorana)
- Neutrino mass (beyond standar model)
- Solar Neutrinos
- GeoNeutrinos
- New Neutrinos?
- Do Neutrinos violate CP symmetry?

1.2) Dark Matter

- Time Modulation
- New Technologies

2) Biology

Cellular Mutation

3) GeoScience

sismography; termochronology; new materials; geodinamic model, litographic mapping;...

4) Nuclear Astrophysics

- General Relativity and Quantum mechanics tests
- Nucleosynthesis of early universe elements and other objetcts

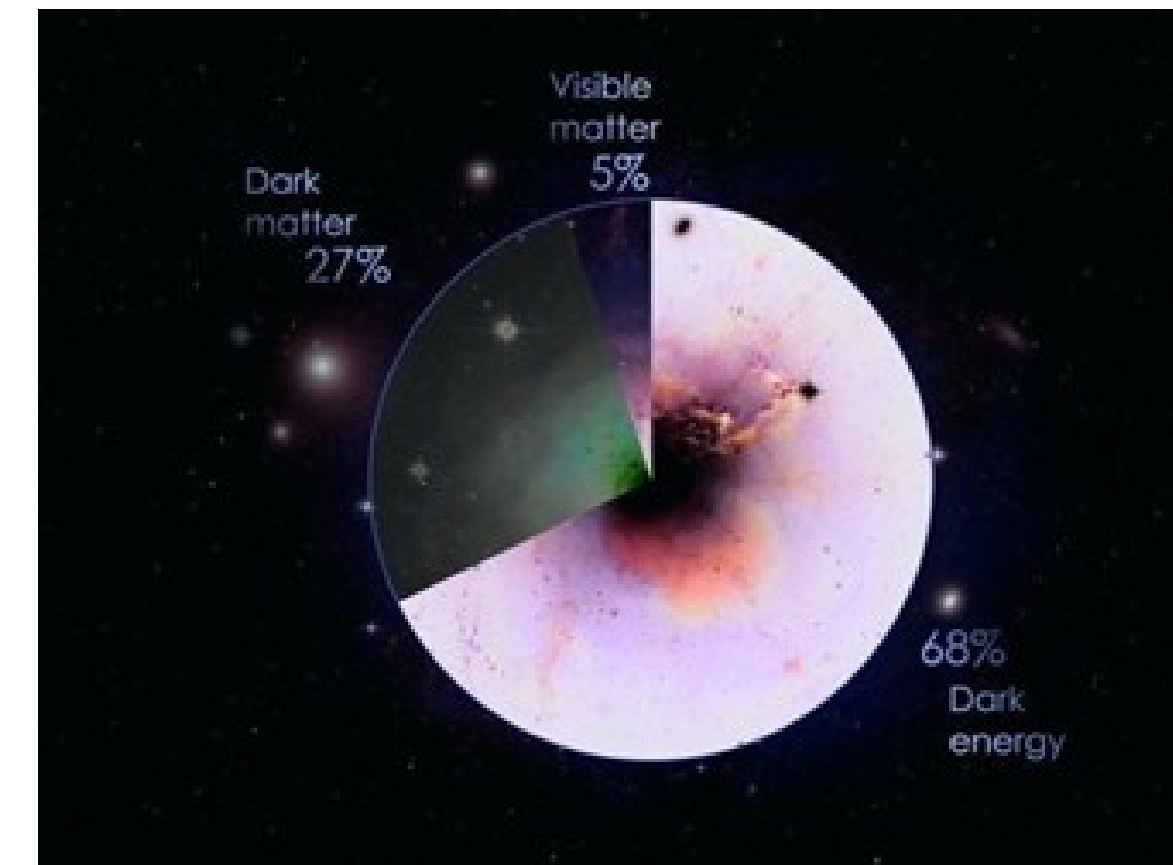

ANDES Laboratory



*Bienvenida Congreso Internacional ANDES
(Junio 2017, Buenos Aires)*

Presidente CNEA O. Calzetta, Ministro Infraestructura San Juan Ing. J.C. Ortiz Andino, Organizador A. Etchegoyen, Ministro MinCyT L. Baraño, Presidente INFN F. Ferroni, Rector UNSAM C. Ruta.



*Bienvenida Congreso Internacional GeoCiencias ANDES
(November 2018, San Juan)*

Subsecretaria de CyT Nación P. Nahirñac, Ministro Infraestructura San Juan J.C. Ortiz Andino, Gobernador S. Uñac, Coordinador Técnico EBITAN A. Zini, Representantes INFN G. Paparo y G. Saccorotti

ANDES- QUBIC: Microelectronics & Electronics

Enabling Technologies ANDES - QUBIC: Quantum Criogenic Sensors

Prototype electronics

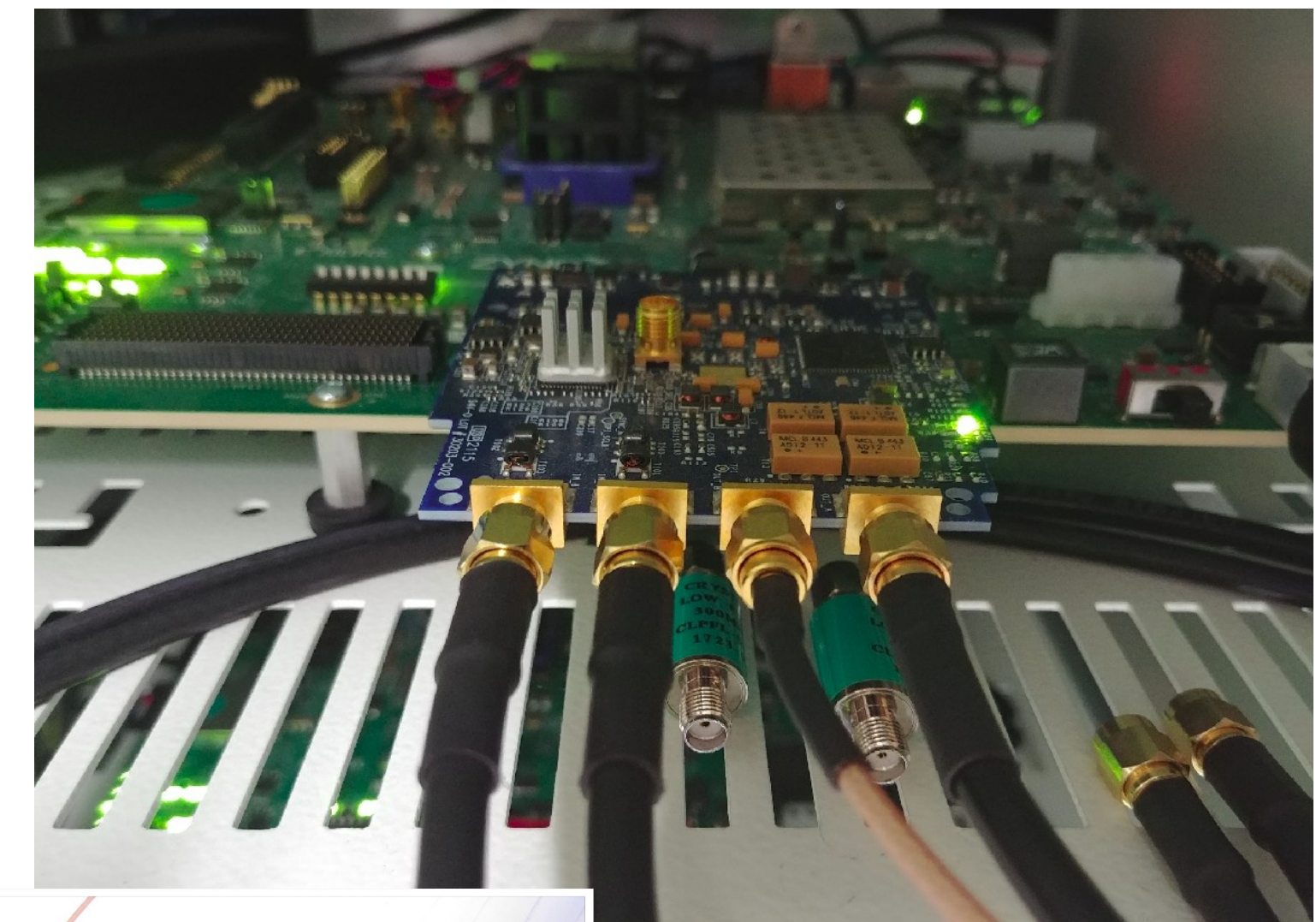
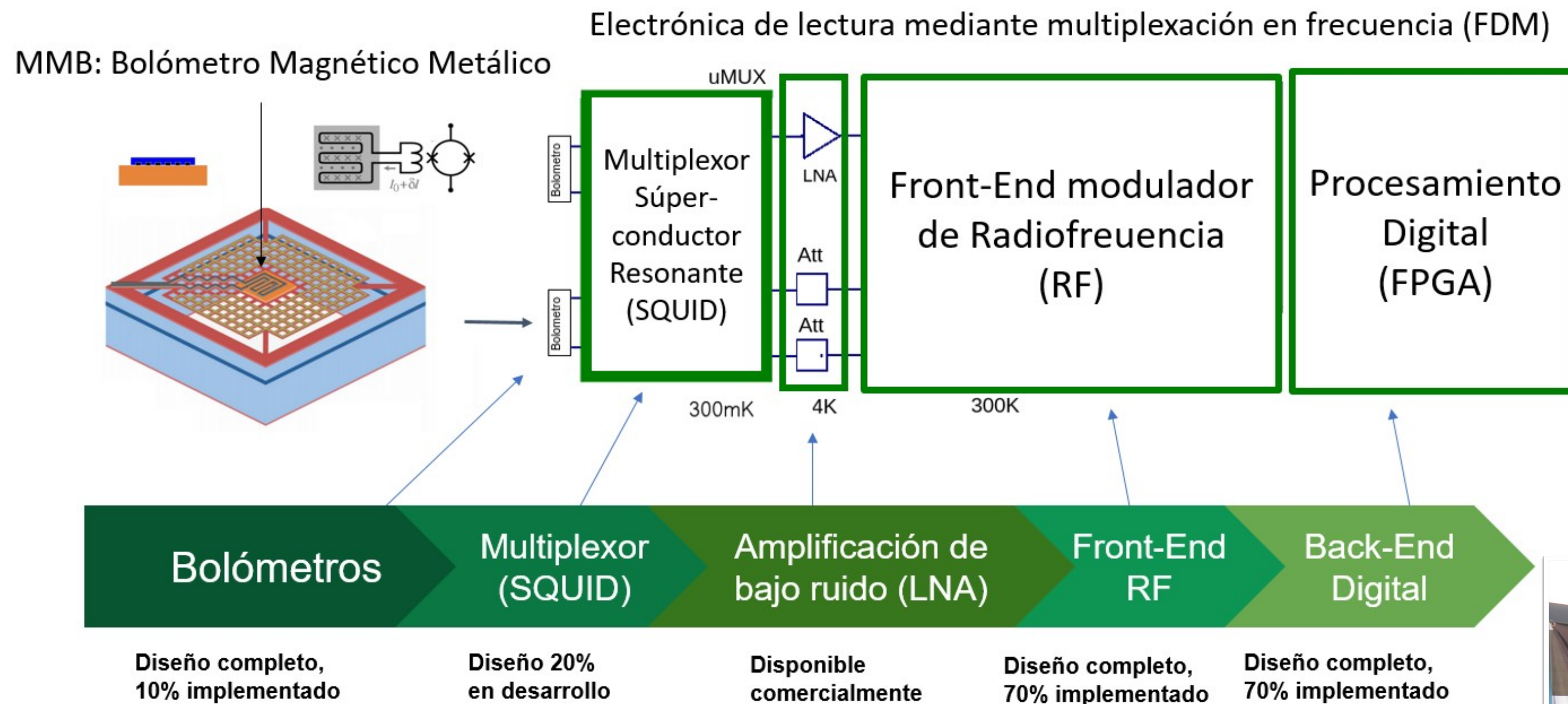

6 Engineers in the KIT-UNSAM double doctoral Degree program.

Microelectronics done by Departamento de Micro y Nano Tecnología - GDTPE, CAC. Colaboration with Mariano Berisso, GF, CAB



Agreement on Astrophysics CNEA-INFN

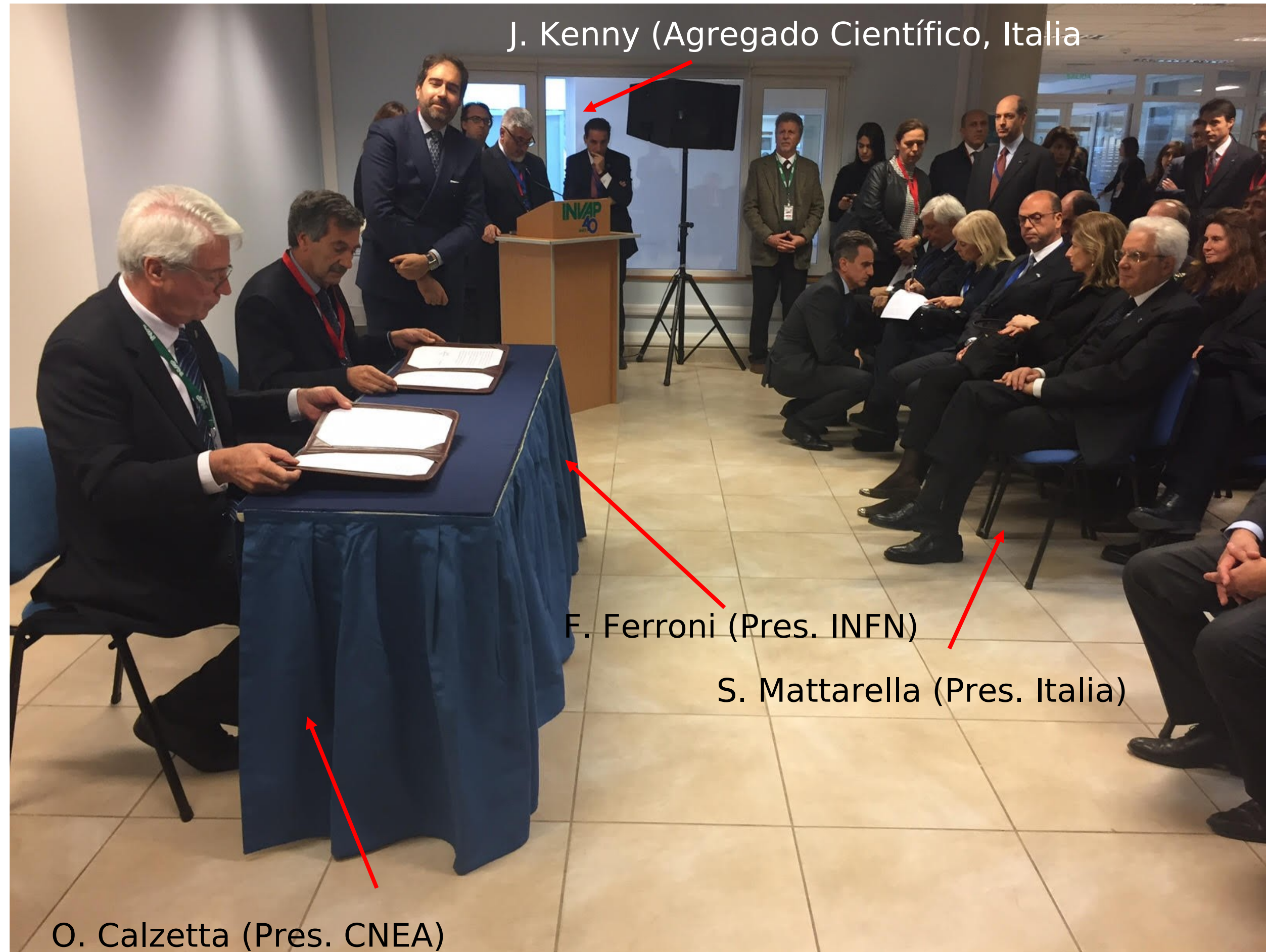

CONVENIO ESPECÍFICO EN ASTROPARTÍCULAS

Entre la COMISIÓN NACIONAL DE ENERGÍA ATÓMICA, en adelante denominada "CNEA", representada en este acto por su Presidente Lic. Osvaldo CALZETTA LARRIEU, por una parte, y el INSTITUTO NACIONAL DE FÍSICA NUCLEAR, en adelante "INFN", representada por su Presidente Prof. Fernando FERRONI, por la otra, acuerdan celebrar el presente CONVENIO ESPECÍFICO encuadrado dentro del MEMORANDO DE ENTENDIMIENTO CIENTÍFICO, en adelante MoU, firmado entre las partes el 15 de noviembre de 2015 que se registrá por las siguientes cláusulas.

Bariloche, República Argentina, a los 10 días del mes de mayo del año 2017.

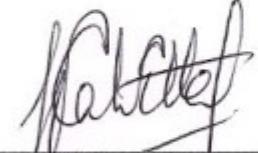
Lic. Osvaldo CALZETTA LARRIEU
Presidente
CNEA

Prof. Fernando FERRONI
Presidente
INFN

40,000 €/year total

Being renewed this year

Auger, ANDES/Gran Sasso, QUBIC



Conclusions

Argentina is hosting large physics international projects (Auger, QUBIC y ANDES) from the southern sky

Argentina and Italy have developed a strong collaboration within Auger and it is being extended to QUBIC and ANDES for which Italy has vast experience (criogenics & astrophysics, geo and bioscience, Gran Sasso)

The Future: Multi-Messenger studies

1. High Energy Neutrinos (ANDES)
2. High Energy Cosmic Rays (Auger)
3. High Energy Gamma Rays (CTA, SWGO)
4. Gravitational Waves (VIRGO, LIGO)

but only feasible by large global international collaborations