

PID Summary

Caltech SuperB Meeting, December 17th 2010

Nicolas Arnaud, for the SuperB PID group



- 2 **parallel sessions**
 - 1 barrel-oriented
 - 1 with misc. topics (forward PID discussed in task force sessions)
- 2 open sessions of the **forward task force**
[+1 joint session fwd TF/bwd TF/DGWG + 1 closed session]
 - Status updates of the FARICH, FTOF and pixelated TOF projects
 - Task force report will follow soon – **not discussed here**

PID Parallel Sessions

- PID parallel sessions

Tuesday, 14 December 2010

[59] **FDIRC prototype CRT test and its impact on FDIRC at SuperB**

by Dr. Jerry VAVRA (SLAC)
(B128 - Baxter Room 128: 11:00 - 11:20)

[60] **FDIRC MC simulation**

by Prof. Douglas ROBERTS (University of Maryland); Dr. Jerry VAVRA (SLAC)
(B128 - Baxter Room 128: 11:20 - 11:40)

[72] **Mechanics for the CRT test**

by Massimo BENETTONI (PD)
(B128 - Baxter Room 128: 11:40 - 12:00)

[73] **Barrel electronics**

by Mr. Christophe BEIGBEDER (LAL)
(B128 - Baxter Room 128: 12:00 - 12:20)

Wednesday, 15 December 2010

[127] **LAL test bench for PMTs**

by Mr. Dominique BRETON (LAL ORSAY)
(B128 - Baxter Room 128: 09:00 - 09:20)

[139] **Quick Report on Radiation Hardness studies on Silicon G-APDs**

by Enrico FELTRESI (PD)
(B128 - Baxter Room 128: 09:20 - 09:40)

- Forward task force sessions

Wednesday, 15 December 2010

[114] **Introductory Remarks**

by Prof. Abolhassan JAWAHERY (University of Maryland)
(B210 - Baxter Room 210: 11:00 - 11:05)

[115] **Physics Impact of Forward PID**

by Matteo RAMA (LNF)
(B210 - Baxter Room 210: 11:05 - 11:45)

[116] **Test Beam Study of Impact FPID on F-EMC**

by Stefano GERMANI (PG)
(B210 - Baxter Room 210: 11:55 - 12:15)

Wednesday, 15 December 2010

[117] **Introduction FTOF (+ Cost Estimate)**

by Prof. Achille STOCCHI (LAL - Université Paris Sud and IN2p3/CNRS); Dr. NICOLAS ARNAUD (LAL ORSAY CNRS-IN2P3)
(B210 - Baxter Room 210: 14:00 - 14:30)

[118] **CRT Experiments: Set-Up/Electronic**

by Mr. Dominique BRETON (LAL ORSAY)
(B210 - Baxter Room 210: 14:30 - 14:55)

[119] **CRT Experiments: Results of Data Analysis**

by Mr. Leonid BURMISTROV (LaL)
(B210 - Baxter Room 210: 14:55 - 15:20)

Wednesday, 15 December 2010

[121] **FARICH & Responses to TF Questions**

by Dr. Evgeniy KRAVCHENKO (Budker INP)
(B210 - Baxter Room 210: 16:00 - 16:40)

[122] **Pixelated TOF & Responses to TF Questions**

by Dr. Jerry VAVRA (SLAC)
(B210 - Baxter Room 210: 16:40 - 17:10)

FDIRC prototype data analysis (J. Va'vra)

- **FDIRC prototype** in SLAC **Cosmic Ray Telescope (CRT)**
- Useful to investigate effects not well-understood
Ex: tails of θ_C distribution (analysis in progress)

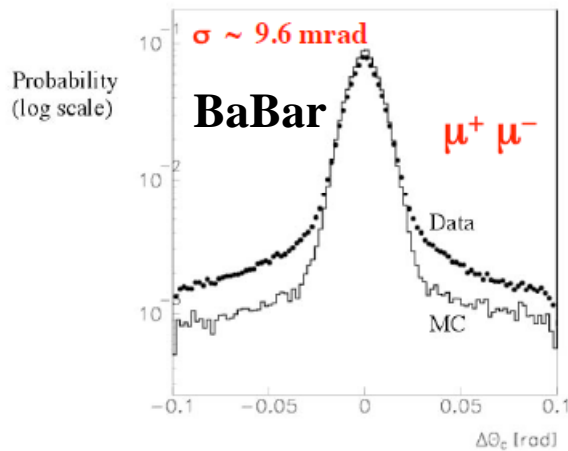

CRT

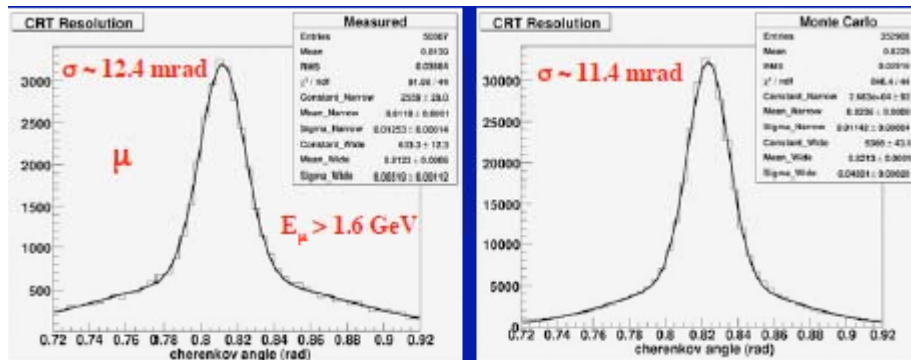

Data

MC

Cosmic Ray Telescope (CRT): (described in SLAC-PUB-13873 (2010):

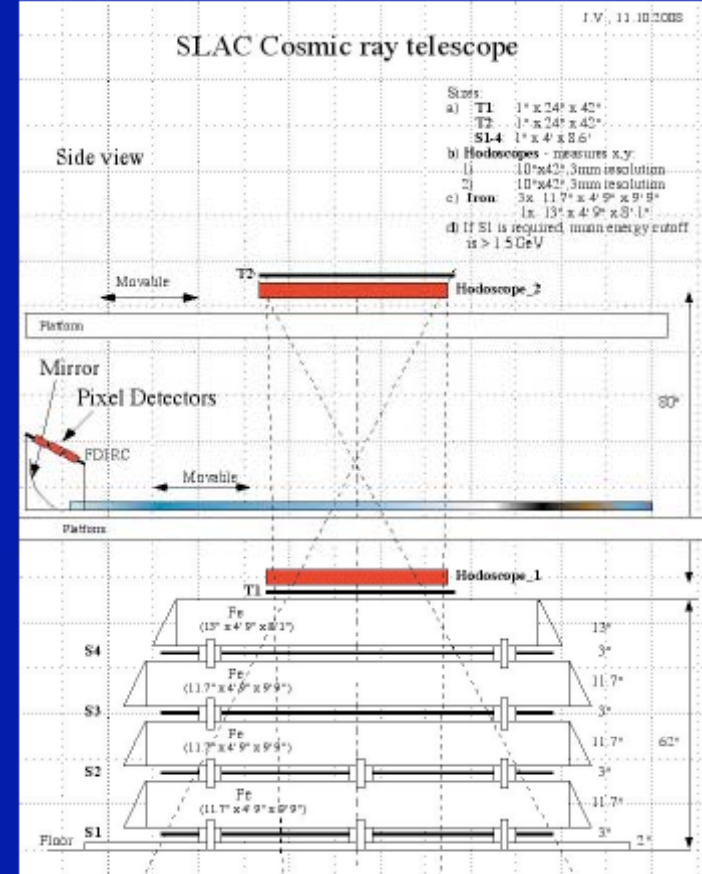

FDIRC prototype data analysis (J. Va'vra)

- More findings on the θ_C resolution:
 - independent from the number of top/bottom bounces in the bar
 - earliest photons (= shortest TOP) give the best resolution
 - resolution gets worse near ring edges
 - Optical aberration ('kaleidoscopic effect') increases with the distance z between the track and the bar end
 - Effect amplified by the mirror
- Cylindrical mirror (as in SuperB) twice better than spherical mirror (as in FDIRC prototype)

Using pixels

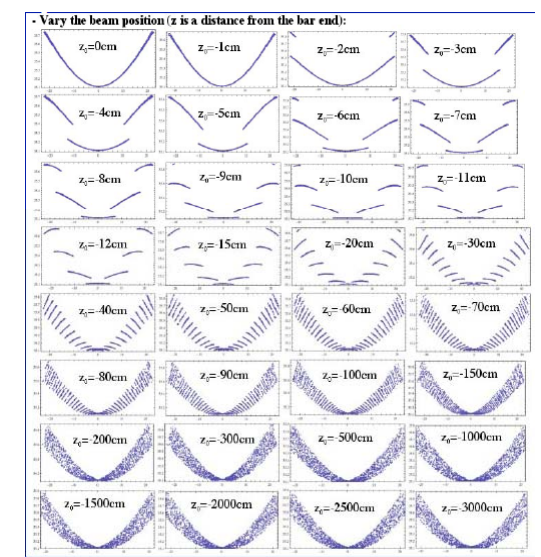
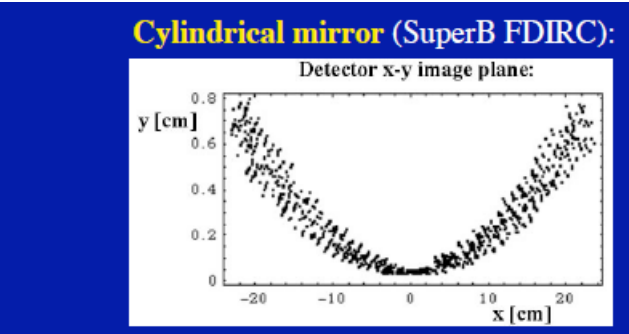
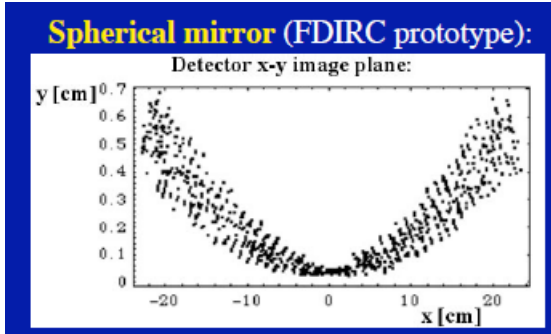
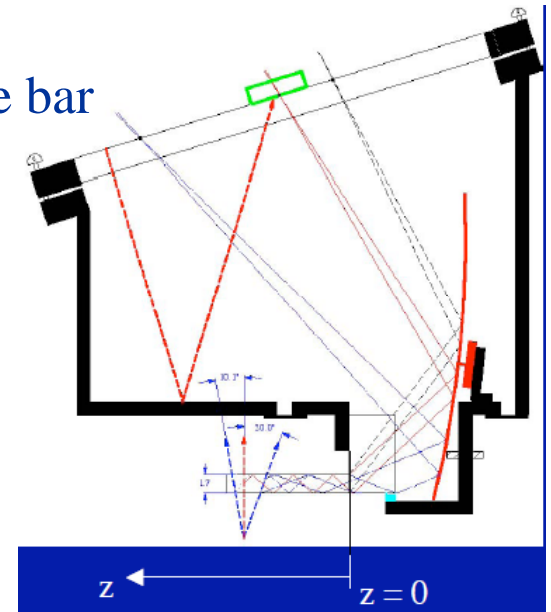

- FDIRC prototype data analysis allow crosschecks with Monte-Carlo simulations (Mathematica ray-tracing)
- Another idea: to use TOP ($\beta=1$) to compute θ_C resolution

FDIRC MC Simulation (D. Roberts)

- Compare performances with and w/o optical coupling between FBLOCK and PMT
 - No coupling (= air) simplifies the PMT maintenance
 - But photons at large angles are partly lost due to index mismatch

⇒ Dimuon MC study

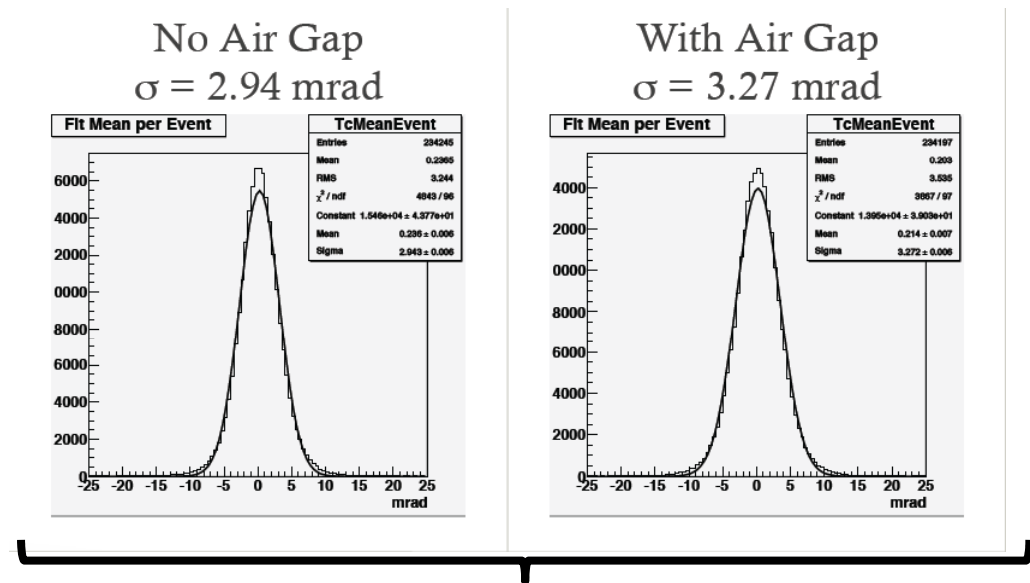
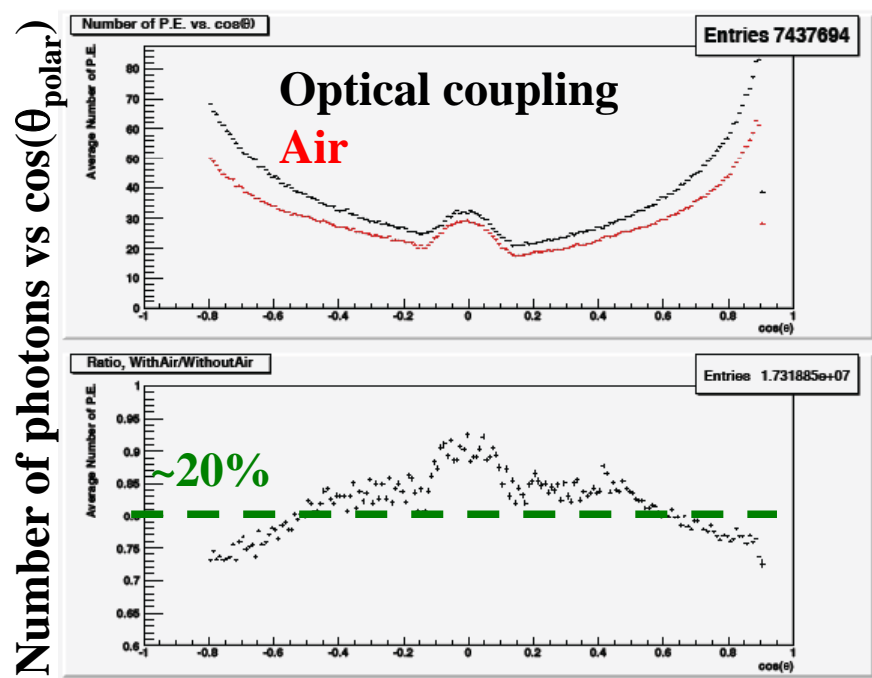

~10% loss in resolution

- Analysis to be refined (timing, chromatic corrections, technique, etc.)

Mechanics for the CRT test (M. Benettoni)

- **SLAC + Padova + Bari**
- Design of the FBLOCK prototype and of its support structure in the CRT
- Many topics under study: clean room assembly, sealing to the bar box, alignment strategy, etc.
- Preliminary workshop drawings ready
- Current **planning**:
 - Production of parts late January-March
→ Machining done by external companies
 - Checks and trial assembly in April
 - Shipping to SLAC April-May
 - **Assembly at SLAC in May**
- ⇒ SLAC-Padova-Bari dedicated meeting to review the schedule and make it possible

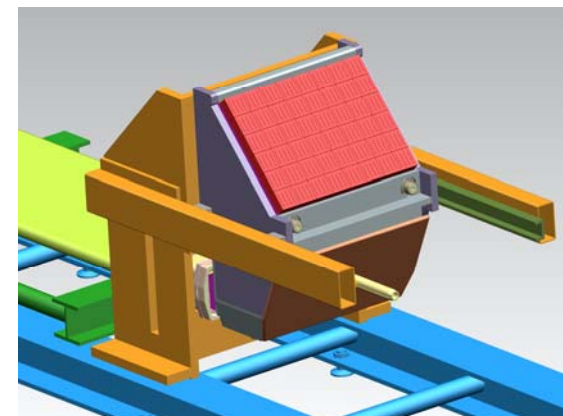
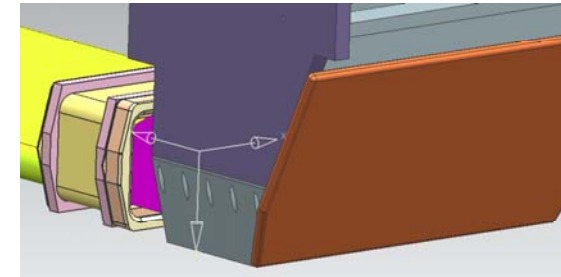
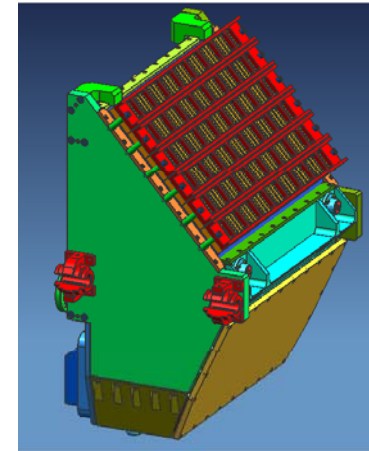

Barrel Electronics (C. Beigbeder)

- Development of two chips

- Front-end: **PIF**

- TDC: **SCATS**

16 channels

70 ps resolution

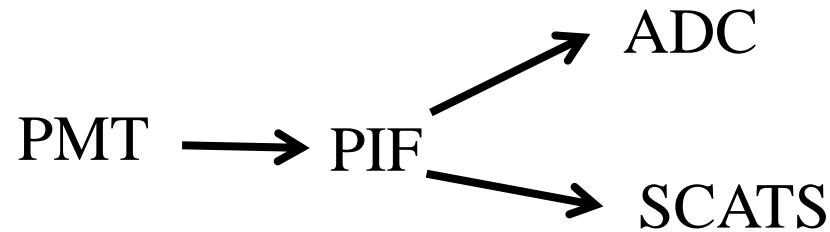

- **SCATS**

- Various progresses: front-end upgrade, readout simulations, RAM design started

- Chip to be submitted in May; 1st prototype available ~3 months later

- **PIF**

- No relevant progress since Frascati meeting

- SCATS simulations help defining specifications for the output design architecture and the synchronization of the PIF chip

→ Architecture to be finalized

- Design of the Common Fraction Discriminator (CFD) will start soon

- H-8500 PMT bought to create a test setup in LAL-Orsay

PM Tests

SiPM n Irradiation Studies (E. Feltresi)

- Irradiation by neutrons of various Si G-APDs at Legnaro
 - **FBK, Hamamatsu**
 - **1 mm² to 9 mm²**
- **Neutron moderator** (10 cm of water) added in front of Si
 - Less energetic neutrons killed

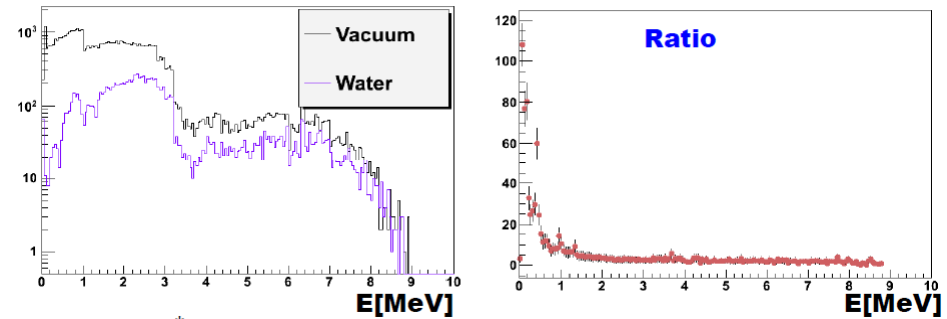

- **FBK device looks promising**

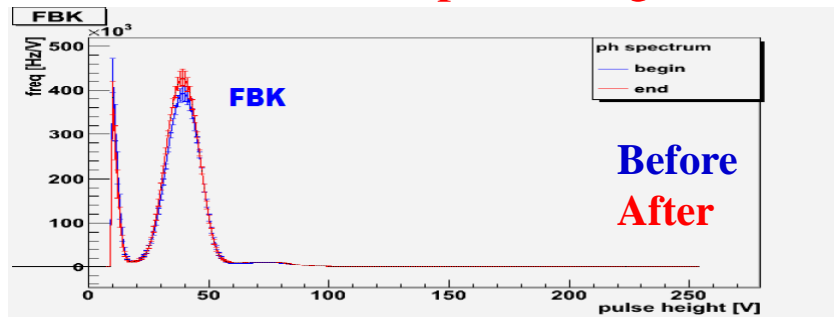

- **Hamamatsu's one doesn't**

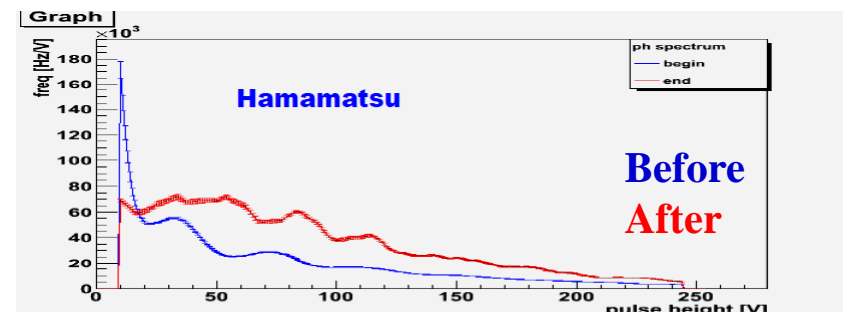

- More work on simulation needed to understand these results
- Plan to test other moderators (paraffin, graphite) in the near future

LAL Test Bench (D. Breton)

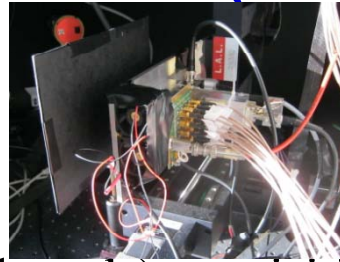

- Test of a Burle MCP-PMT (25 μm)
- Electronics: 16-channel (8 **USBWC** boards) acquisition crate identical to the one used at SLAC for CRT tests
- Preliminary map produced
 - Test bench optimizations needed
- Important results for the electronics already achieved

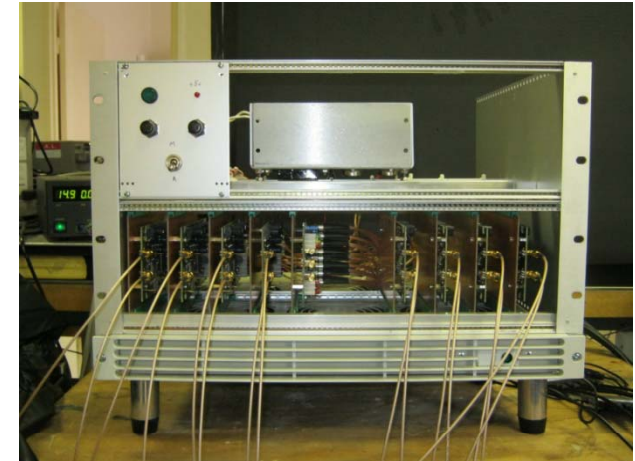

- **Time performance of the multiboard system**

- **Find and fix an USB buffer problem inside the DAQ PC which was a source of synchro losses between boards**

→ See forward PID slides

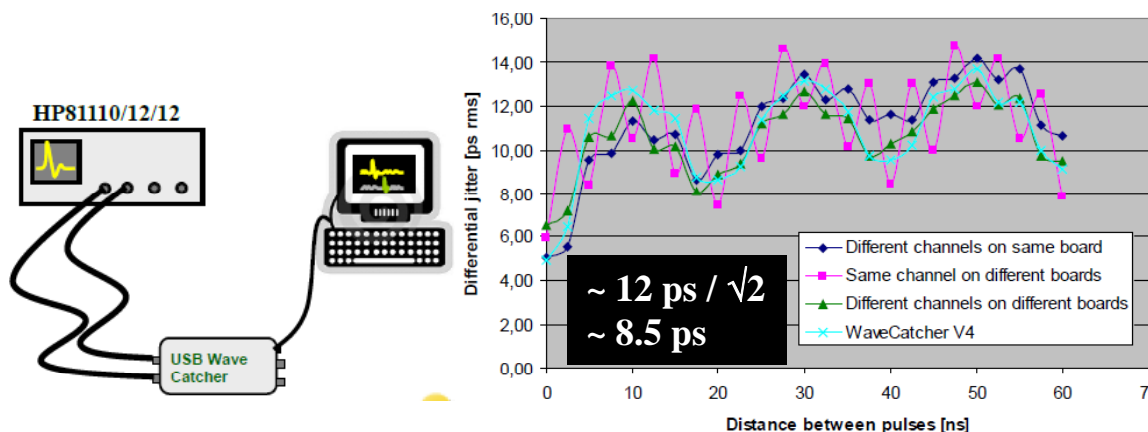

→ Design of a 16-channel board in progress

Forward PID

FTOF Update (LAL, SLAC)

- New iteration on **the cost: ~ 2 M€**
→ PMT cost alone is ~1.2 M€
- **Recent activities centered on the CRT test @ SLAC**
→ **Leonid's work**

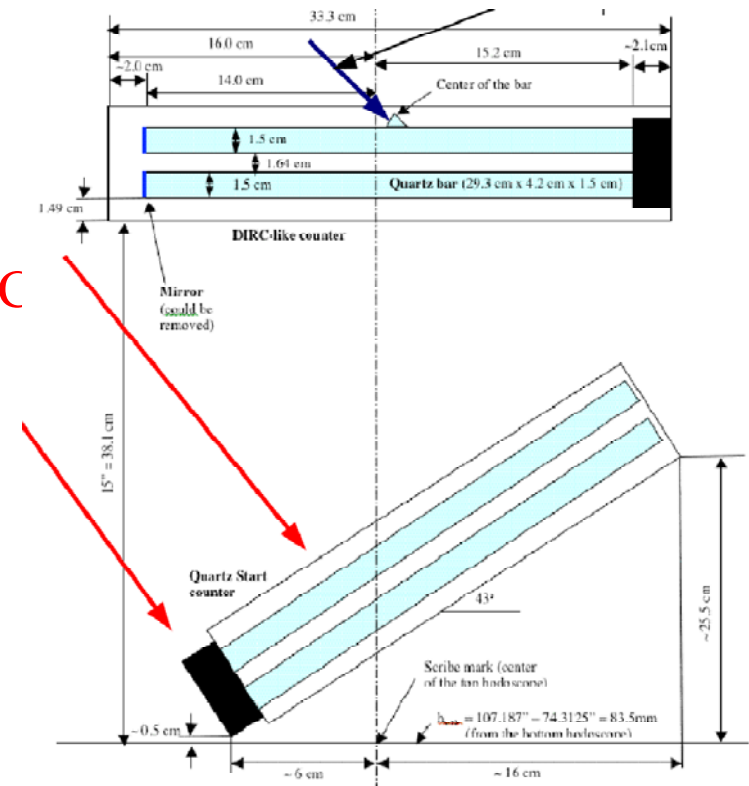
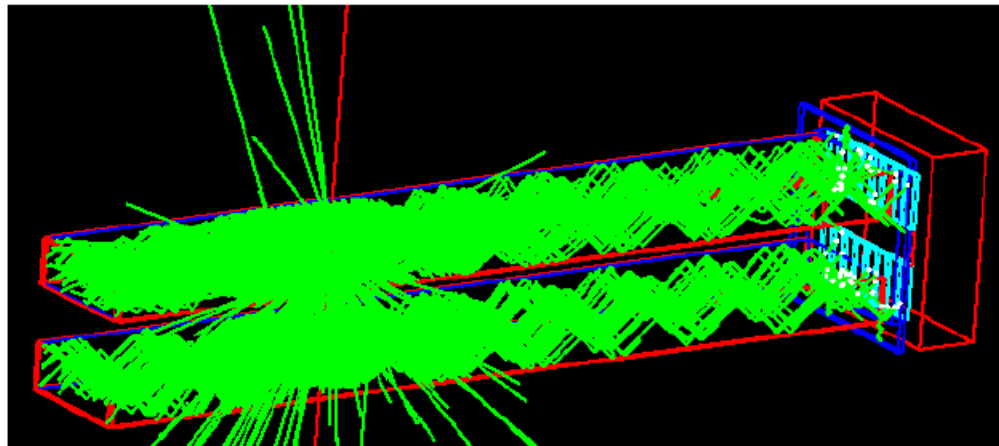

- CRT and USBWC DAQ systems are separated for technical reasons
→ **Timing coincidences used to match events and hence select energetic muons**
- **Simulation developed to help understanding the data**
→ **Key features of the setup discovered**

FTOF Update (LAL, SLAC)

- Significantly **more than 1 ph.e. per channel**
- **Most of the late ph.e. arrive less than 1 ns (PMT rise time) after the first ph.e.**
 \Rightarrow CFD algorithm (used to measure timing) performances are degraded

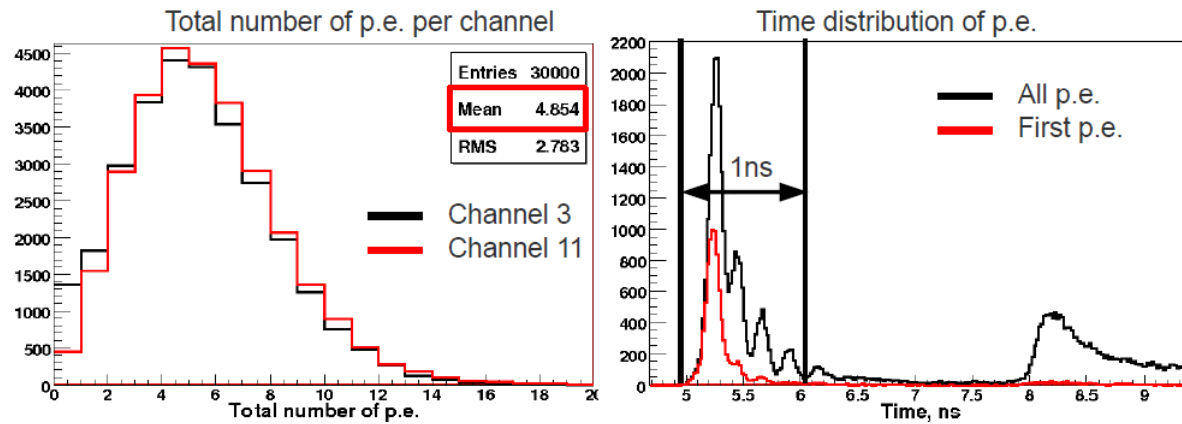

- No absolute time \Rightarrow **Compute differences between 2 channels**
- **Simulation results do depend on the track parameters**

	σ , ps	fraction, %
wide	221.5	45.5
narrow	59.5	50.5

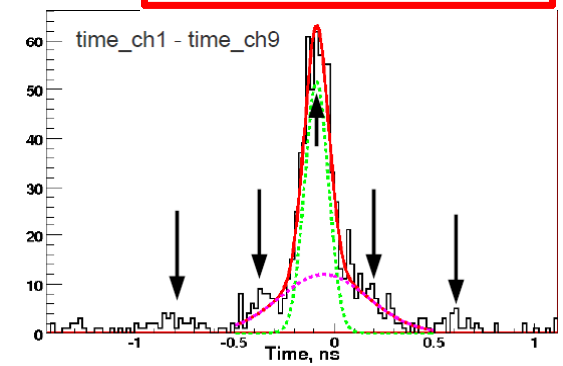
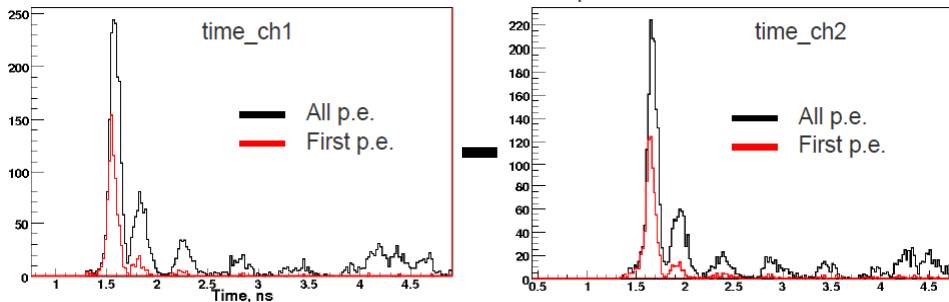

FTOF Update (LAL, SLAC)

- Significantly **more than 1 ph.e. per channel**
- **Most of the late ph.e. arrive less than 1 ns (PMT rise time) after the first ph.e.**
 \Rightarrow CFD algorithm (used to measure timing) performances are degraded

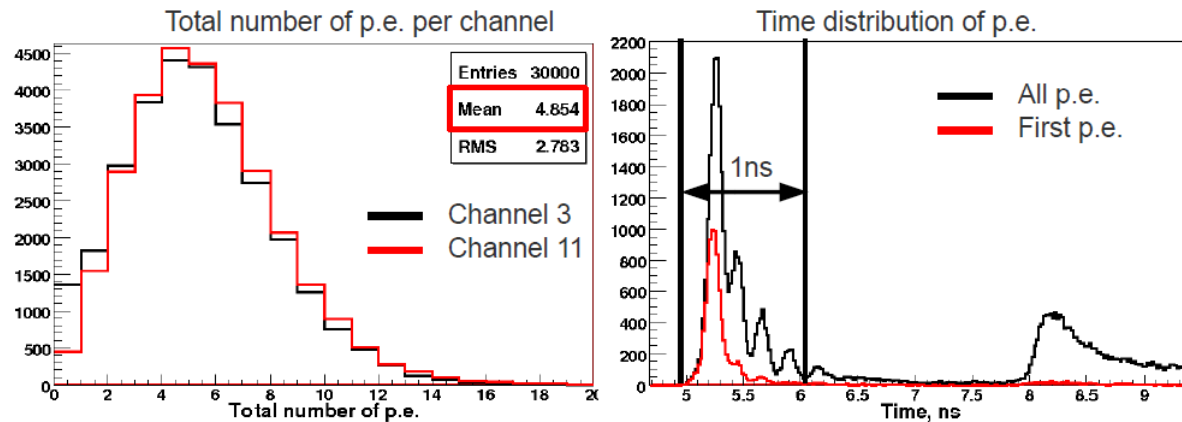

- No absolute time \Rightarrow **Compute differences between 2 channels**
- **Simulation results do depend on the track parameters**

	σ , ps	fraction, %
Wide	1644	88.7
Narrow	80	11.3

11

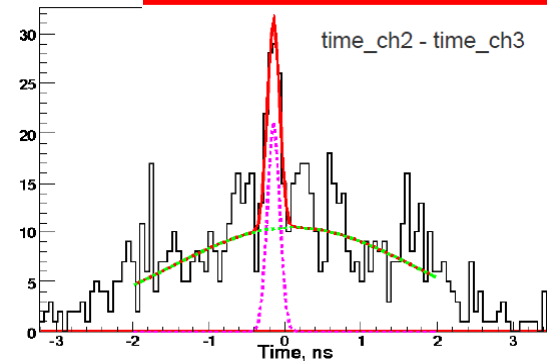
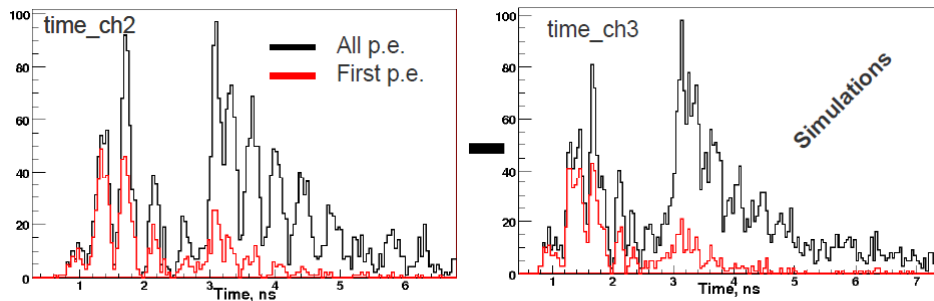

FTOF Update (LAL, SLAC)

- **Problem** discovered at LAL on 12/06 about **USBWC board synchronization**
 - Some USBWC buffers may not be emptied properly: then, the waveforms recorded at a given time in the 16 channels would come from different events!
 - **Impossible to match CRT and USBWC events** ☹
 - **Fixed software running at CRT since 12/08**; first results expected soon (low rate)
- Only possibility for now: **integrate all events (muons) together and make time differences between channels of the same board (no desynchronization)**
 - Keep **'clean' waveforms** (remove crosstalks and multipеaks) only

Simulation results

	σ , ps	fraction, %
wide	254.5	42
narrow	67.3	58

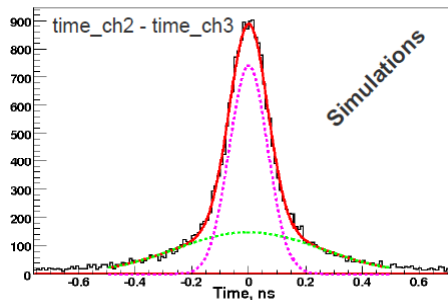

Evidence of desynchronization in data

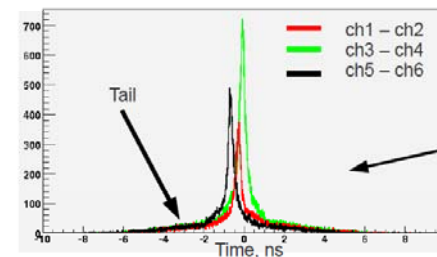

Comparison of channels from different boards

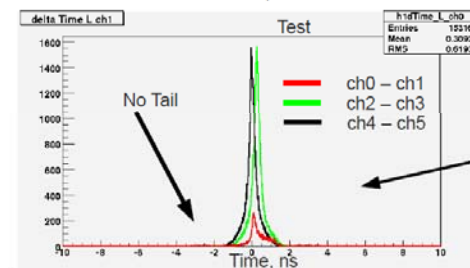

Comparison of channels from the same board

FTOF Update (LAL, SLAC)

- Limited agreement between data and simulation so far

	σ ,ps	fraction, %
wide	254.5	42
Narrow	67.3	58

Time resolution/channel:
 $67.3/\text{sqrt}(2) \sim 50\text{ps}$

	σ ,ps	fraction, %
wide	470.5	54
Narrow	129.0	46

Time resolution/channel:
 $129.3/\text{sqrt}(2) \sim 90\text{ps}$

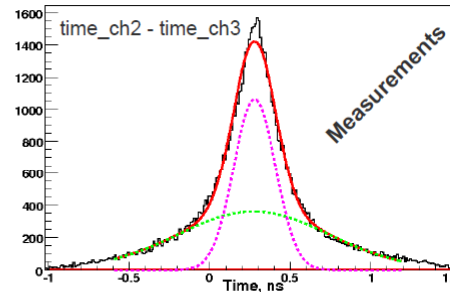
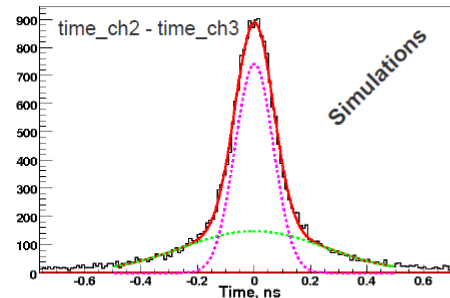

⇒ **Simulation needs to be improved** to account for the main setup features.
In particular, the PMT will be simulated

- **Future plans**

- Try to **reduce the # of ph.e.**

- Rotate the counter a bit [in DIRC, minimum yield @ $\cos(\theta) \sim 0.15$]

- Put absorber in front of PMT

- **Switch to SL 10:** rise time twice faster and twice more channels

FARICH (E. Kravchenko)

- Concluding slide from Evgeniy's talk

- FARICH with an excellent performance is proposed.
- Background rate is under control.
- Aging of MCP PMTs is minor.
- 25% of X0 of additional material in the endcap
- Degradation of momentum resolution for forward tracks
- Absence of experimental results from the prototype from our group

The gain in efficiency for selected physics channels is about 5%.

The cost of the system is around 3.5 Millions Euros

- Prototype status

- 2+2 focusing aerogel tiles ready to be tested
- SiPMTs used as photon detectors
- Beam tests scheduled in January-February 2011

Pixilated TOF (J. Va'vra)

- Hamamatsu G-APDs in front of a long LYSO crystal (forward EMC)

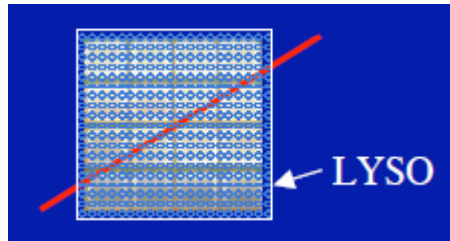

4x4 array

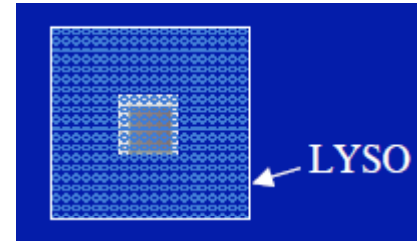

Single 9 mm²

- Left setup being currently tested in CRT at SLAC
→ Results expected beginning of January (low DAQ rate)

- Right setup to be tested early next year

- $\sigma \sim 136$ ps for a short LYSO crystal
→ Promising performances

- Main points to be studied:

cost, electronics (link from detector, location, specs, etc.), signal yield

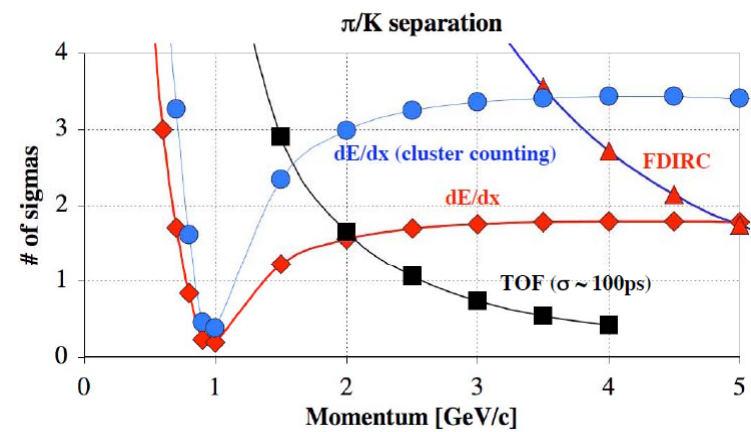

Conclusions

Outlook

- **Progress in Barrel and Forward areas**
 - Despite lack of manpower (hard to focus on various topics in parallel) and lack of approval... until today
- **The SLAC CRT is definitely the device where to make PID tests**
 - This setup needs some support to be maintained
 - ... and manpower to be operated and to analyze its data
- Efforts are TDR-oriented
- Hope that approval brings us part of the missing manpower soon...

