

SCIENTIFIC CHALLENGES EXPECTED FROM FUTURE GROUND-BASED EXPERIMENTS

SUZANNE STAGGS
PRINCETON UNIVERSITY
23 MAY 22 @ FERRARA



CHALLENGES

Invitation prompt: What are the most prominent instrumental or astrophysical limitations future CMB experiments are likely to encounter, and how do you expect to overcome them?

CHALLENGES

Invitation prompt: What are the most prominent instrumental or astrophysical limitations future CMB experiments are likely to encounter, and how do you expect to overcome them?

Prompt answer: This Meeting's Talk Titles

CHALLENGES

Invitation prompt: What are the most prominent instrumental or astrophysical limitations future CMB experiments are likely to encounter, and how do you expect to overcome them?

Prompt answer: This Meeting's Talk Titles

Implied question from title: What are the challenges for future ground-based CMB experiments?

challenge, *n.*

Forms: *a.* Middle English–1500s *calenge*, (Middle English *caleng*, 1500s *challenge* ...

Frequency (in current use):

Etymology: Middle English *calenge*, *chalance*, < Old French *ca-*, *challenge*, *-lange*, originally ...

1. An accusation, charge, reproach, objection.

2.

a. The act of calling to account; *esp.* the act of a sentry in demanding the countersign.

b. *Hunting.* The opening and crying of hounds at finding the scent; see **CHALLENGE** *v.* (In modern dictionaries.)

3. *Law.*

a. 'An Exception taken, against either persons or things' (P^lunt); *spec.* an objection made to one or more of the jurymen in a trial, as in **principal challenge**, **peremptory challenge**, **challenge to the array**, **challenge to the polls**, **challenge to the favour**. Also, an exception taken to a vote, etc.

b. *East India.* (See quot. 1858.)

4. A calling in question or disputing; the state of being called in question.

5. A claim; the act of demanding as a right. In early use, often, a false claim. *Obsolete.*

6.

a. An invitation or summons to a trial or contest of any kind; a defiance.

b. **In weakened use:** a difficult or demanding task, esp. one seen as a test of one's abilities or character.

1954 W. FAULKNER *Fable* 23 It was not that his trained professional judgment told him that the affair...would be touch-and-go and hence more than doubtful...that would have been a challenge, as if the old destiny had not abandoned him at all.

1957 A. E. STEVENSON *New Amer.* III. IV. 147 One of tomorrow's great challenges will be to make good use of what will very possibly be a greatly increased leisure.

1966 *Hockey Coaching* (Hockey Association) 5 The game of hockey in this country is facing a real challenge.

1972 E. LONGFORD *Wellington* xxii. 340 Today the Martyrs' Memorial stands like a rock of tranquillity in the roaring currents of the twentieth century, an occasional challenge to the climbing skills of students, pot in hand.

1979 D. HALBERSTAM *Powers that Be* (1980) i. ii. 71 He almost seemed to welcome the challenge of the war, it would test America's worthiness.

7. *spec.* A summons to fight, *esp.* to single combat or duel.

8. *attributive.*

1813 W. SCOTT *Bridal of Triermain* III. x. 142 The valiant Knight of Triermain Rung forth his challenge-blast again.

9. The action or process of administering an immunogenic agent to an animal or person in order to study the resulting immune response, or of exposing an animal or person to an infectious agent, *esp.* to measure the efficacy of a vaccine. Frequently as a modifier, *esp.* in **challenge study**, **challenge trial**. Cf. **CHALLENGE** *v.* 9.

CHALLENGES

6b. In weakened use: a difficult or demanding task, esp. one seen as a test of one's abilities or character.

Invitation prompt: What are the most prominent instrumental or astrophysical limitations future CMB experiments are likely to encounter, and how do you expect to overcome them?

Prompt answer: This Meeting's Talk Titles

Implied question from title: What are the challenges for future ground-based CMB experiments?

challenge, *n.*

Forms: *a.* Middle English–1500s *calenge*, (Middle English *caleng*, 1500s *challenge* ...
Frequency (in current use):
Etymology: Middle English *calenge*, *chalance*, < Old French *ca-*, *challenge*, *-lange*, originally ...

1. An accusation, charge, reproach, objection.

2.
a. The act of calling to account; *esp.* the act of a sentry in demanding the countersign.

b. *Hunting.* The opening and crying of hounds at finding the scent; see CHALLENGE *v.* (In modern dictionaries.)

3. Law.
a. 'An Exception taken, against either persons or things' (P^lunt); *spec.* an objection made to one or more of the jurymen in a trial, as in **principal challenge**, **peremptory challenge**, **challenge to the array**, **challenge to the polls**, **challenge to the favour**. Also, an exception taken to a vote, etc.

b. *East India.* (See quot. 1858.)

4. A calling in question or disputing; the state of being called in question.

5. A claim; the act of demanding as a right. In early use, often, a false claim. *Obsolete.*

6.
a. An invitation or summons to a trial or contest of any kind; a defiance.

b. **In weakened use:** a difficult or demanding task, esp. one seen as a test of one's abilities or character.

1954 W. FAULKNER *Fable* 23 It was not that his trained professional judgment told him that the affair...would be touch-and-go and hence more than doubtful...that would have been a challenge, as if the old destiny had not abandoned him at all.

1957 A. E. STEVENSON *New Amer.* III. IV. 147 One of tomorrow's great challenges will be to make good use of what will very possibly be a greatly increased leisure.

1966 *Hockey Coaching* (Hockey Association) 5 The game of hockey in this country is facing a real challenge.

1972 E. LONGFORD *Wellington* xxii. 340 Today the Martyrs' Memorial stands like a rock of tranquillity in the roaring currents of the twentieth century, an occasional challenge to the climbing skills of students, pot in hand.

1979 D. HALBERSTAM *Powers that Be* (1980) I. II. 71 He almost seemed to welcome the challenge of the war, it would test America's worthiness.

7. spec. A summons to fight, *esp.* to single combat or duel.

8. attributive.

1813 W. SCOTT *Bridal of Triermain* III. X. 142 The valiant Knight of Triermain Rung forth his challenge-blast again.

9. The action or process of administering an immunogenic agent to an animal or person in order to study the resulting immune response, or of exposing an animal or person to an infectious agent, *esp.* to measure the efficacy of a vaccine. Frequently as a modifier, *esp.* in **challenge study**, **challenge trial**. Cf. CHALLENGE *v.* 9.

CHALLENGES

6b. In weakened use: a difficult or demanding task, esp. one seen as a test of one's abilities or character.

Invitation prompt: What are the most prominent instrumental or astrophysical limitations future CMB experiments are likely to encounter, and how do you expect to overcome them?

Prompt answer: This Meeting's Talk Titles

Implied question from title: What are the challenges for future ground-based CMB experiments?

Talk Answers:

Atmosphere

Production Capacity

Access

Problems Not Yet Dreamt Of

challenge, *n.*

Forms: *a.* Middle English–1500s *calenge*, (Middle English *caleng*, 1500s *challenge* ...
Frequency (in current use):
Etymology: Middle English *calenge*, *chalance*, < Old French *ca-*, *challenge*, *-lange*, originally ...

†1. An accusation, charge, reproach, objection.

2.
a. The act of calling to account; *esp.* the act of a sentry in demanding the countersign.

b. *Hunting.* The opening and crying of hounds at finding the scent; see CHALLENGE *v.* (In modern dictionaries.)

3. *Law.*
a. 'An Exception taken, against either persons or things' (P^lunt); *spec.* an objection made to one or more of the jurymen in a trial, as in **principal challenge**, **peremptory challenge**, **challenge of the array**, **challenge to the polls**, **challenge to the favour**. Also, an exception taken to a vote, etc.

b. *East India.* (See quot. 1858.)

4. A calling in question or disputing; the state of being called in question.

†5. A claim; the act of demanding as a right. In early use, often, a false claim. *Obsolete.*

6.
a. An invitation or summons to a trial or contest of any kind; a defiance.

b. *In weakened use:* a difficult or demanding task, esp. one seen as a test of one's abilities or character.

1954 W. FAULKNER *Fable* 23 It was not that his trained professional judgment told him that the affair...would be touch-and-go and hence more than doubtful...that would have been a challenge, as if the old destiny had not abandoned him at all.

1957 A. E. STEVENSON *New Amer.* III. IV. 147 One of tomorrow's great challenges will be to make good use of what will very possibly be a greatly increased leisure.

1972 E. LONGFORD *Wellington* xxii. 340 Today the Martyrs' Memorial stands like a rock of tranquillity in the roaring currents of the twentieth century, an occasional challenge to the climbing skills of students, pot in hand.

1979 D. HALBERSTAM *Powers that Be* (1980) I. II. 71 He almost seemed to welcome the challenge of the war, it would test America's worthiness.

7. *spec.* summons to fight, *esp.* to single combat or duel.

8. *attributive.*

1813 W. SCOTT *Brief of Triermain* III. X. 142 again.

9. The action or process of administering to an animal or person in order to study the response to, or exposing an animal or person to, an infection, esp. to test the efficacy of a vaccine. Frequently a **challenge trial**. Cf. CHALLENGE *v.* 9.

CHALLENGES

6b. In weakened use: a difficult or demanding task, esp. one seen as a test of one's abilities or character.

Invitation prompt: What are the most prominent instrumental or astrophysical limitations future CMB experiments are likely to encounter, and how do you expect to overcome them?

Prompt answer: This Meeting's Talk Titles

Implied question from title: What are the challenges for future ground-based CMB experiments?

Talk Answers:

Atmosphere

Production Capacity

Access

Problems Not Yet Dreamt Of

1972 E. LONGFORD *Wellington* xxii. 340 Today the Martyrs' Memorial stands like a rock of tranquillity in the roaring currents of the twentieth century, an occasional challenge to the climbing skills of students, pot in hand.

ANTICIPATED LIMITATIONS TO OVERCOME

Signals are **small**

Instrumental systematics are **not**

(e.g. due to beams, $I \rightarrow P$ & other polarization effects)

Celestial foregrounds are **not**

(direct contamination, masking impacts, onus on understanding bandpasses)

Local environmental contaminations are **not**

(e.g atmosphere, ground, Starlink)

Numbers of detectors and receivers needed are **not**

(use dilution fridges, high multiplexing factors, automated assembly)

Data sets are **not**

(simulations, rerunning analyses , keeping track of metadata & products are tough)

PARTICULARLY SO FOR GROUND-BASED INSTRUMENTS

Signals are **small**

Instrumental systematics are **not**

(e.g. due to beams, $I \rightarrow P$ & other polarization effects)

Celestial foregrounds are **not**

(direct contamination, masking impacts, onus on understanding bandpasses)

Local environmental contaminations are **not**

(e.g atmosphere, ground, Starlink)

Numbers of detectors and receivers needed are **not**

(use dilution fridges, high multiplexing factors, automated assembly)

Data sets are **not**

(simulations, rerunning analyses , keeping track of metadata & products are tough)

PARTICULARLY SO FOR GROUND-BASED INSTRUMENTS

Signals are **small**

CAVEAT: Some instrumental systematics are aggravated by the local environment

Instrumental systematics are **not**

(e.g. due to beams, I→P & other polarization effects)

Celestial foregrounds are **not**

(direct contamination, masking impacts, onus on understanding bandpasses)

Local environmental contaminations are **not**

(e.g. atmosphere, ground, Starlink)

Numbers of detectors and receivers needed are **not**

(use dilution fridges, high multiplexing factors, automated assembly)

Data sets are **not**

(simulations, rerunning analyses, keeping track of metadata & products are tough)

challenge, *n.*

Forms: *a.* Middle English–1500s *calenge*, (Middle English *caleng*, 1500s *challenge* ...

Frequency (in current use):

Etymology: Middle English *calenge*, *chalance*, < Old French *ca-*, *challenge*, *-lange*, originally ...

1. An accusation, charge, reproach, objection.

2.

a. The act of calling to account; *esp.* the act of a sentry in demanding the countersign.

b. *Hunting.* The opening and crying of hounds at finding the scent; see CHALLENGE *v.* (In modern dictionaries.)

3. *Law.*

a. 'An Exception taken, against either persons or things' (P^lunt); *spec.* an objection made to one or more of the jurymen in a trial. *cf.* in *principal challenge*, *peremptory challenge*, *challenge to the array*, *challenge to the polls*, *challenge to the favour*. Also, an exception taken to a vote, etc.

b. *East India.* (See quot. 1858.)

4. A calling in question or disputing; the state of being called in question.

5. A claim; the act of demanding as a right. In early use, often, a false claim. *Obsolete.*

6.

a. An invitation or summons to a trial or contest of any kind; a defiance.

b. In weakened use: a difficult or demanding task, esp. one seen as a test of one's abilities or character.

1954 W. FAULKNER *Fable* 23 'It was not that his trained professional judgment told him that the affair would be touch-and-go and hence more than doubtful, that would have been a challenge, as if the old destiny had not abandoned him at all.'

1957 A. E. SUNDEN *New Amer.* III, iv, 347 'One of tomorrow's great challenges will be to make good use of what will very possibly be a greatly increased leisure.'

1966 *Hockey Coaching* (Hockey Association) 5 'The game of hockey in this country is facing a real challenge.'

1972 E. LINDFORD *Wellington* xlii, 340 'Today the Martyrs' Memorial stands like a rock of tranquillity in the roaring currents of the twentieth century, an occasional challenge to the climbing skills of students, pot in hand.'

1979 D. HALBERSTAM *Powers that Be* (1980) I, ii, 71 'He almost seemed to welcome the challenge of the war, it would test America's worthiness.'

7. *spec.* A summons to fight, *esp.* to single combat or duel.

8. *attributive.*

1813 W. SCOTT *Bridal of Triermain* III, x, 142 'The valiant Knight of Triermain Rung forth his challenge-blast again.'

9. The action or process of administering an immunogenic agent to an animal or person in order to study the resulting immune response, or of exposing an animal or person to an infectious agent, *esp.* to measure the efficacy of a vaccine. Frequently as a modifier, *esp.* in *challenge study*, *challenge trial*. Cf. CHALLENGE *v.* 9.

CHALLENGES

6b. In weakened use: a difficult or demanding task, esp. one seen as a test of one's abilities or character.

Atmosphere

Production Capacity

Access

Problems Not Yet Dreamt Of

ATMOSPHERE. ATMOSPHERE. ATMOSPHERE. ATMOSPHERE.

It gets in the way.

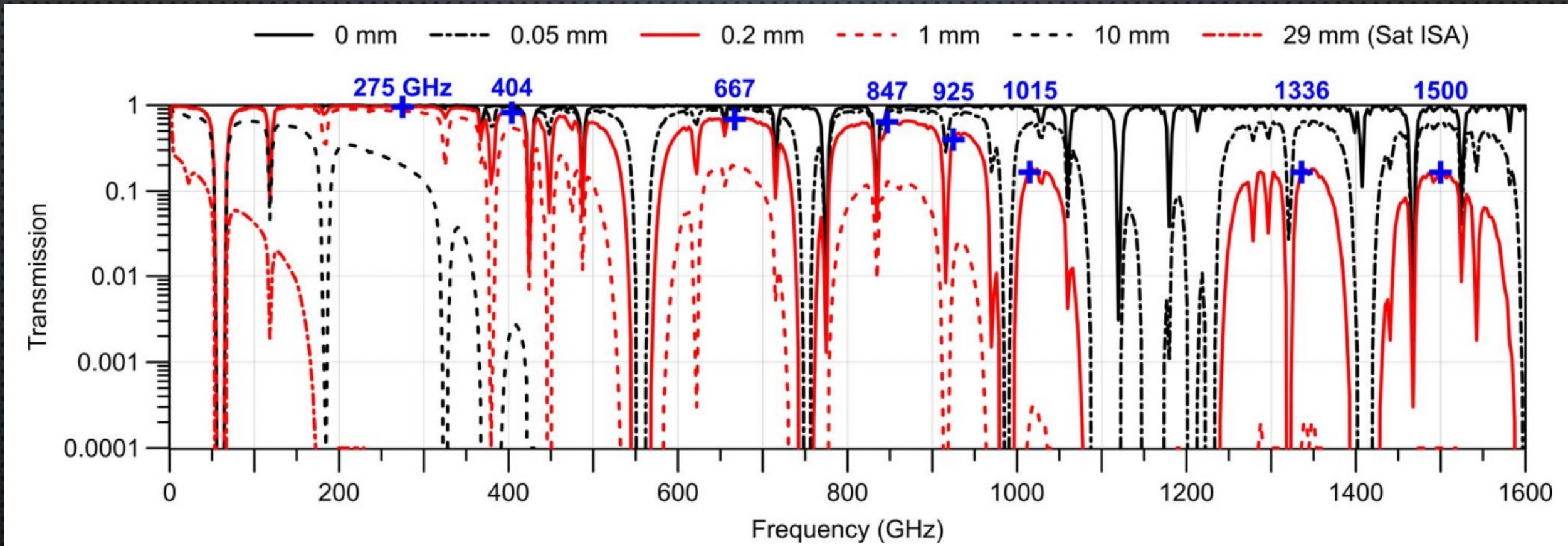

ATMOSPHERE. ATMOSPHERE. ATMOSPHERE. ATMOSPHERE.

Yuen, Fang & Lubin, 2014;; doi: 10.1109/THZ.2013.2294018.

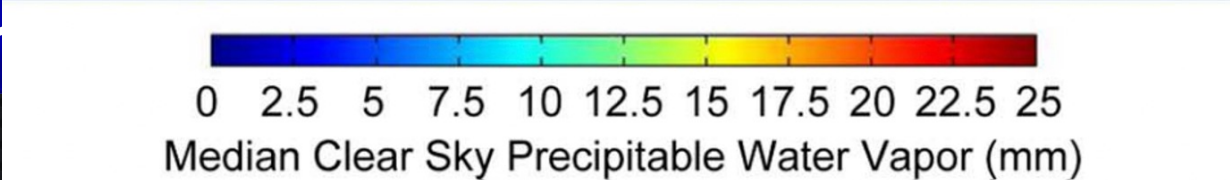
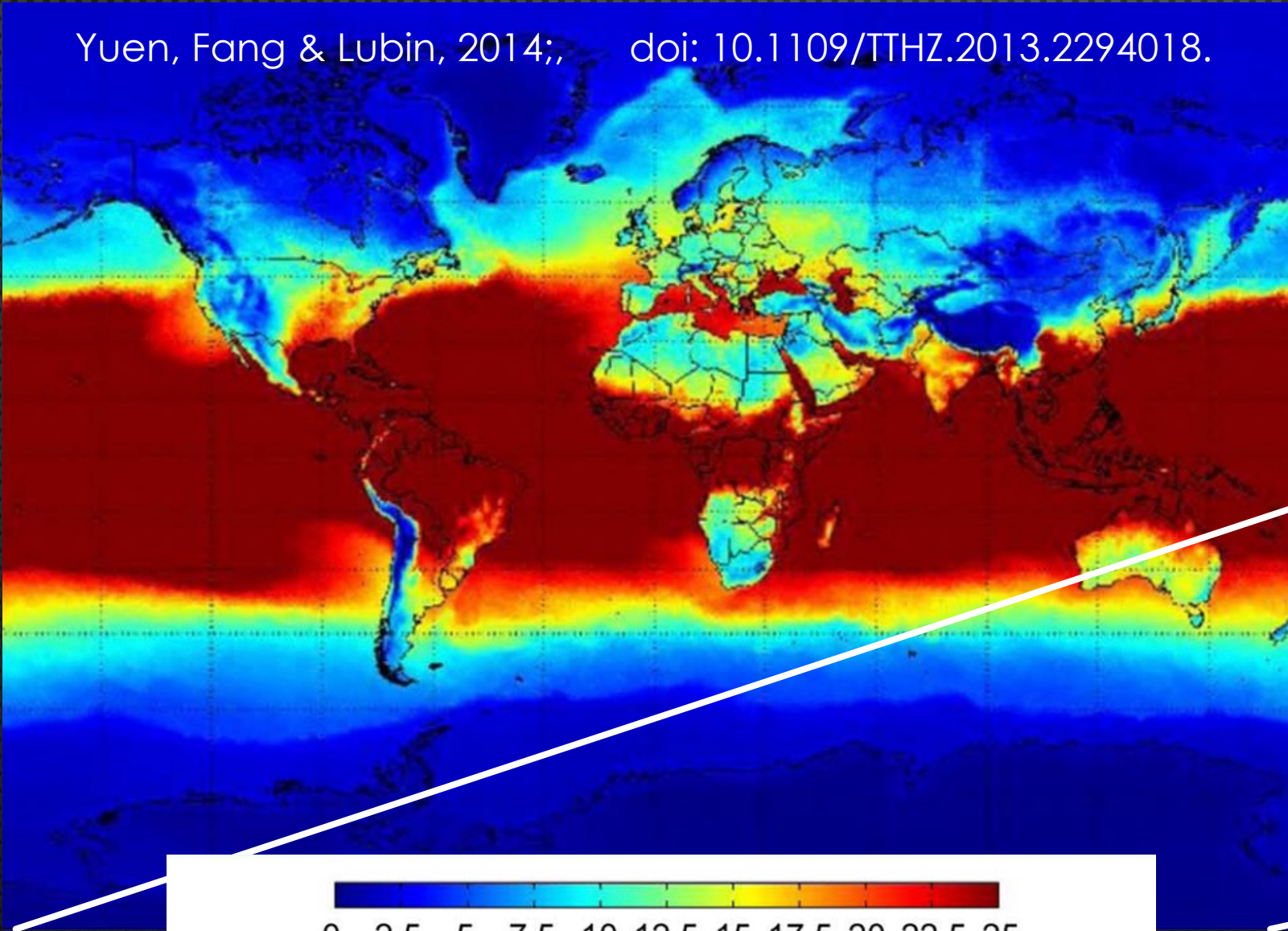

It gets in the way.

Go dry or go home!

Except for $f < 20$ GHz

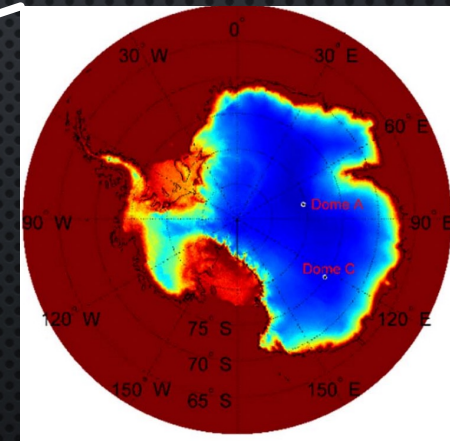

- Atacama Desert
- Antarctica
- Tibetan Plateau
- Greenland

Also see work by Denis Barkats +

ATMOSPHERE. ATMOSPHERE. ATMOSPHERE. ATMOSPHERE.

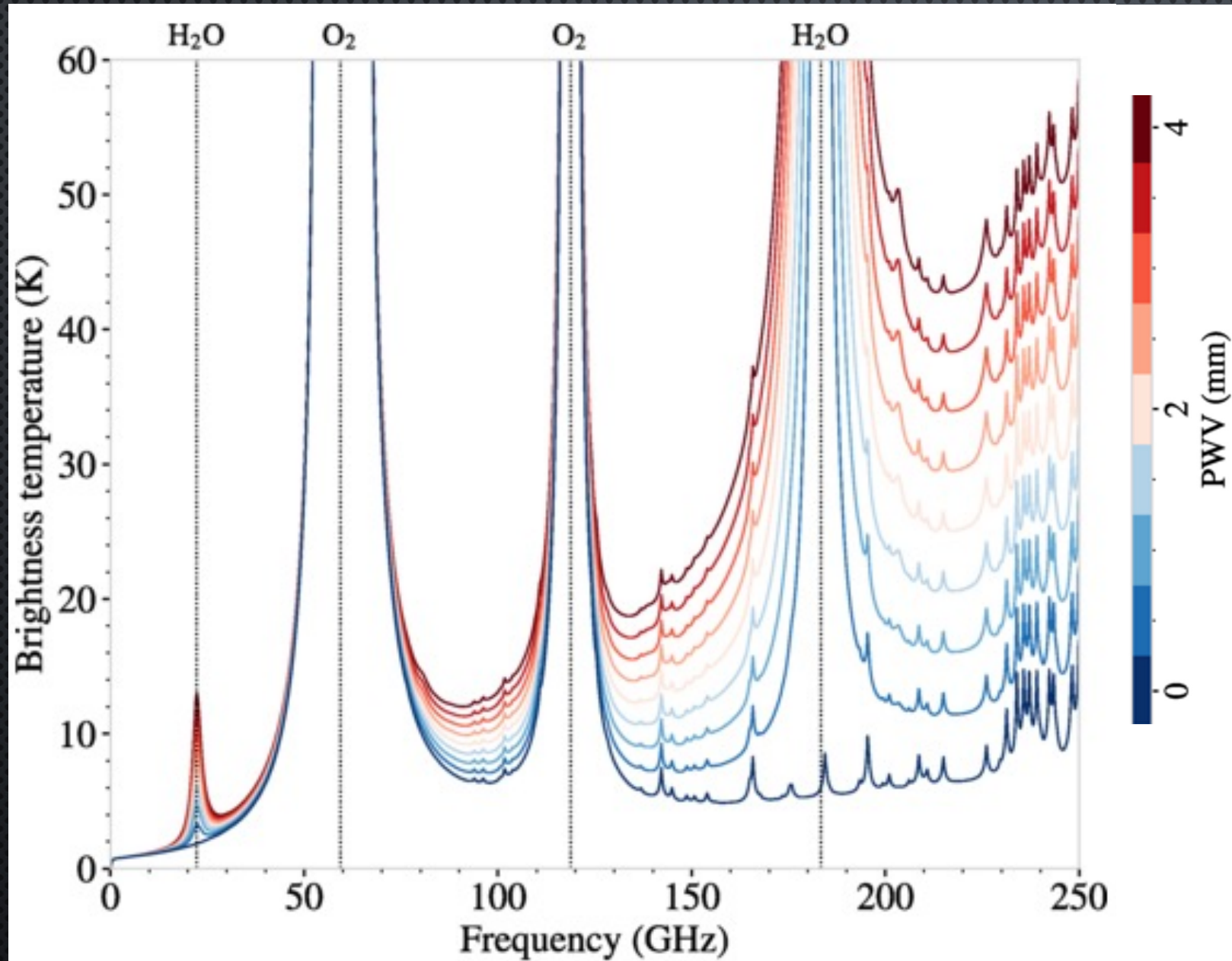

It gets in the way.

And it adds spurious signal.

Extra signal = extra loading.

The signal varies with elevation,

The signal is not constant.

PWV varies with time.

PWV varies with position.

Figure adapted from Morris et al, 2022, PRD 105, 042004; using the am software (S. Paine, 10.5281/zenodo.5794521)

ATMOSPHERE. ATMOSPHERE. ATMOSPHERE. ATMOSPHERE.

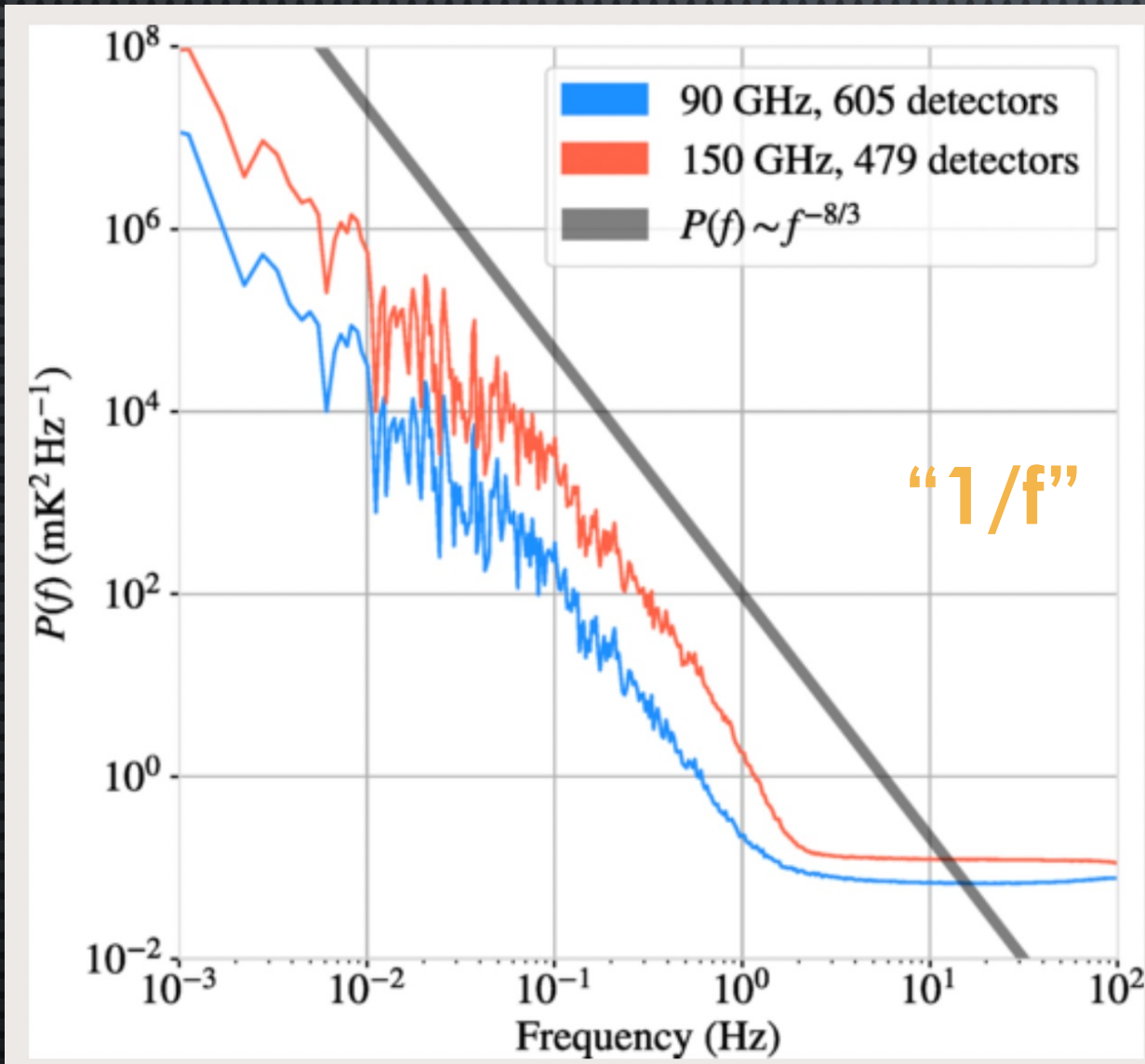

It gets in the way.

And it adds spurious signal.

Extra signal = extra loading.

The signal varies with elevation,

The signal is not constant.

PWV varies with time.

PWV varies with position.

Data taken with ACT fixed in place (not scanning).

ATMOSPHERE. ATMOSPHERE. ATMOSPHERE. ATMOSPHERE.

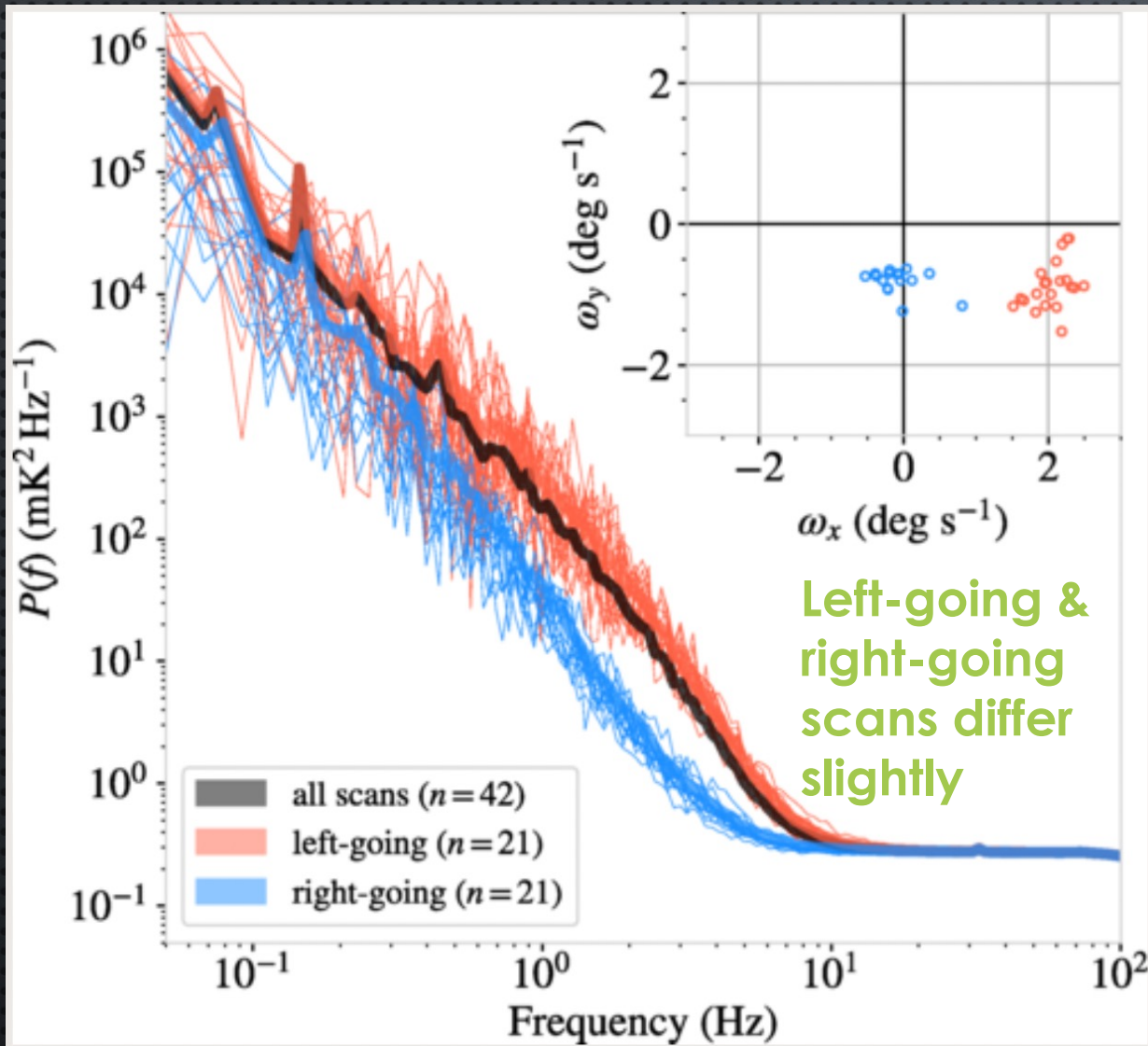

It gets in the way.

And it adds spurious signal.

Extra signal = extra loading.

The signal varies with elevation,

The signal is not constant.

PWV varies with time.

PWV varies with position.

Data taken at 150 GHz
with ACT scanning.

PWV VARIATIONS LEAD TO EXTRA LOW- ℓ NOISE

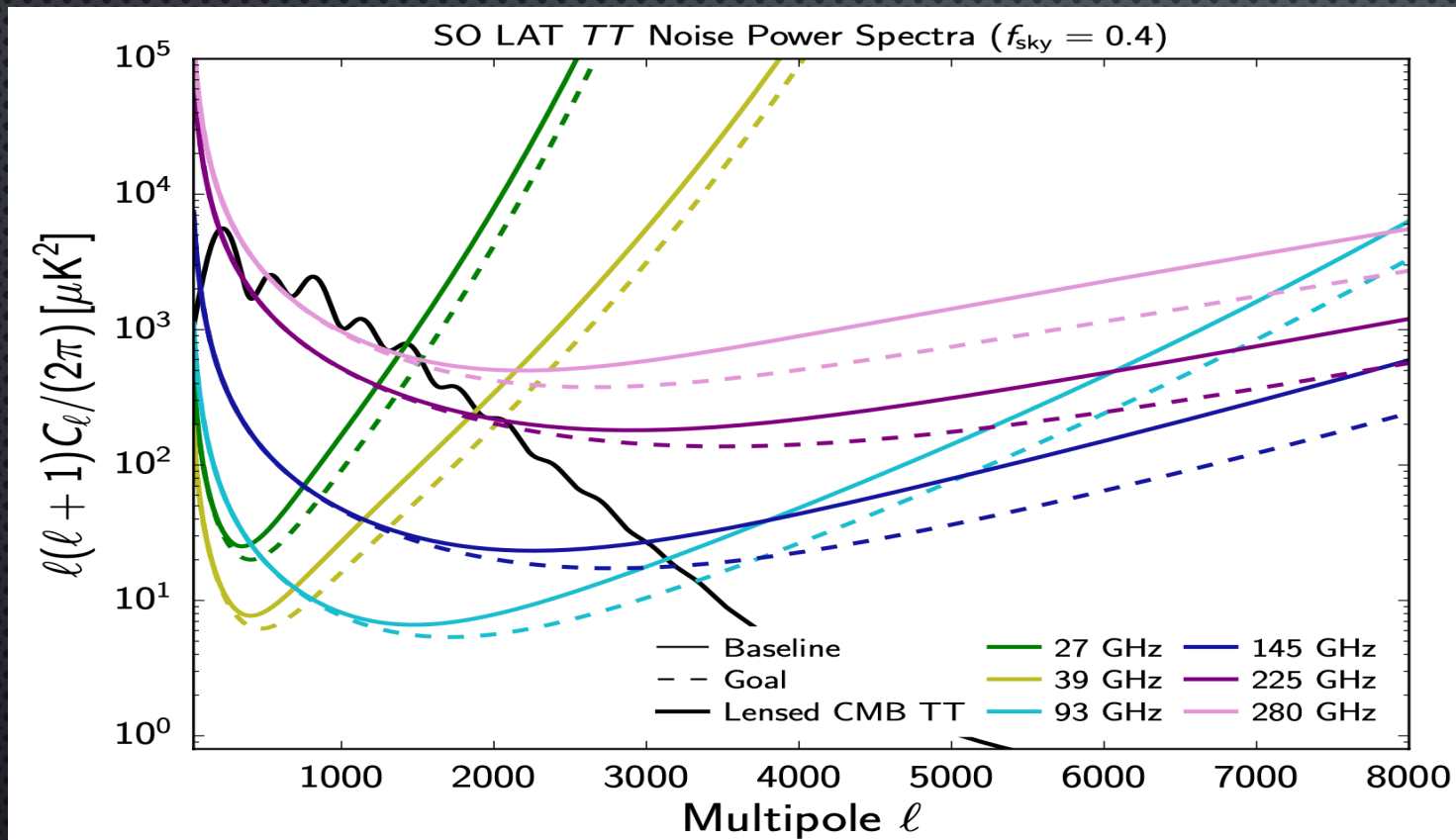

Temperature (TT)

Focus on solid dark blue
150 GHz curve

The SO Large Aperture Telescope will be based in Chile.

These plots show the SO forecasting noise model, based on ACTpol data.

The beam is apparent at high ℓ and the atmosphere at low ℓ .

Overcome this limitation with good modeling, optimal scan strategy, and analysis accommodations.

From SO Collaboration, 'The Simons Observatory: Science Goals and Forecasts,' 2019 JCAP02(2019) 056.

PWV VARIATIONS LEAD TO EXTRA LOW-ELL NOISE

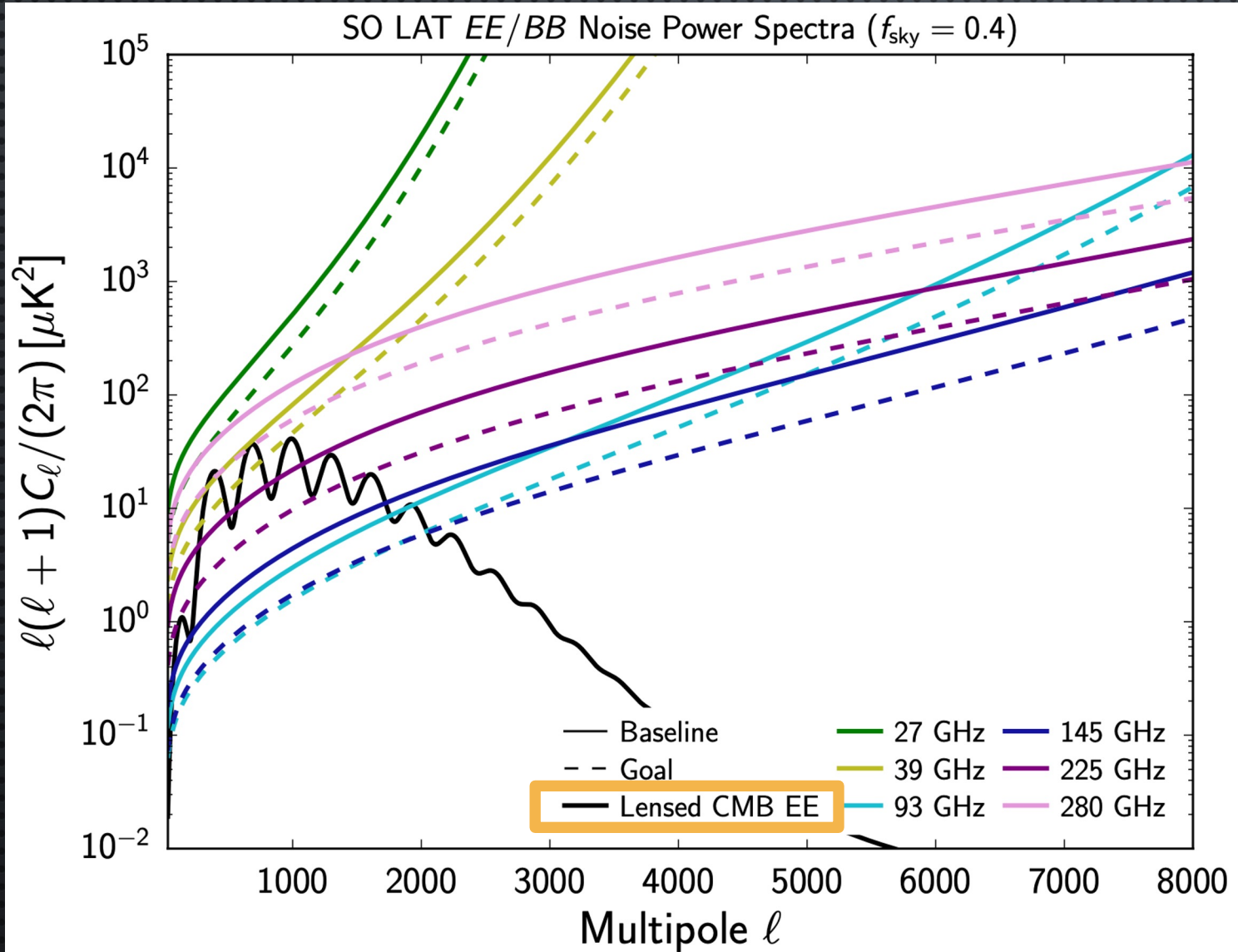

Polarization (EE/BB)

Focus on solid dark blue
150 GHz curve

Polarization is less impacted by $1/f$ (empirically).

These plots show the SO forecasting noise model, based on ACTpol data.

The beam is apparent at high l and the atmosphere at low l .

From SO Collaboration, 'The Simons Observatory: Science Goals and Forecasts,' 2019 JCAP02(2019) 056.

PWV VARIATIONS LEAD TO EXTRA LOW-ELL NOISE

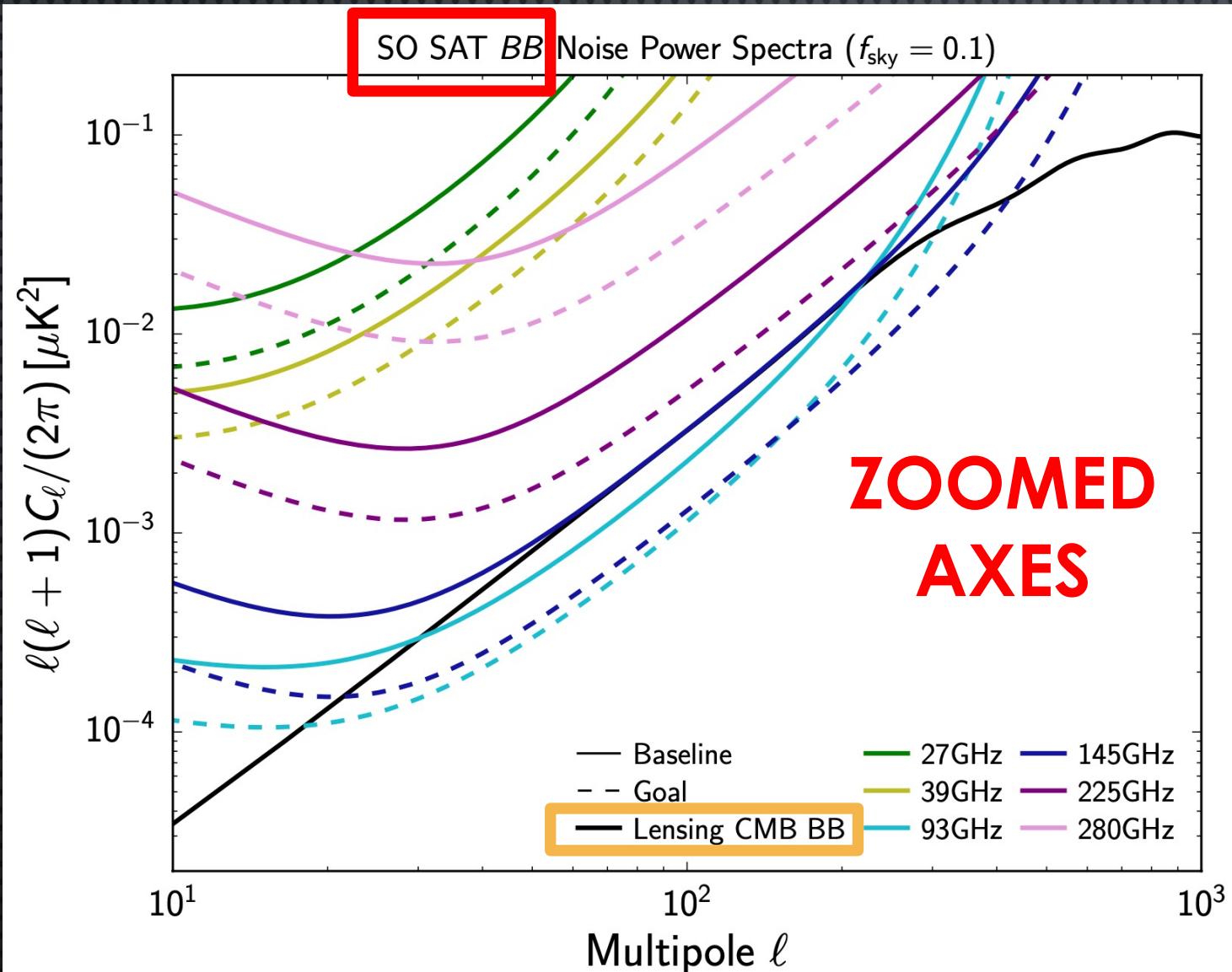

Polarization (BB)

Focus on solid dark blue 150 GHz curve

SO also has Small Aperture Telescopes (SATs).

This SO SAT noise model is based on multiple small aperture instruments. But; **needs confirmation!**

The beam is apparent at high ℓ and the atmosphere at low ℓ .

From SO Collaboration, 'The Simons Observatory: Science Goals and Forecasts,' 2019 JCAP02(2019) 056.

CORRELATED ATMOSPHERE COMPLICATES NOISE MODEL

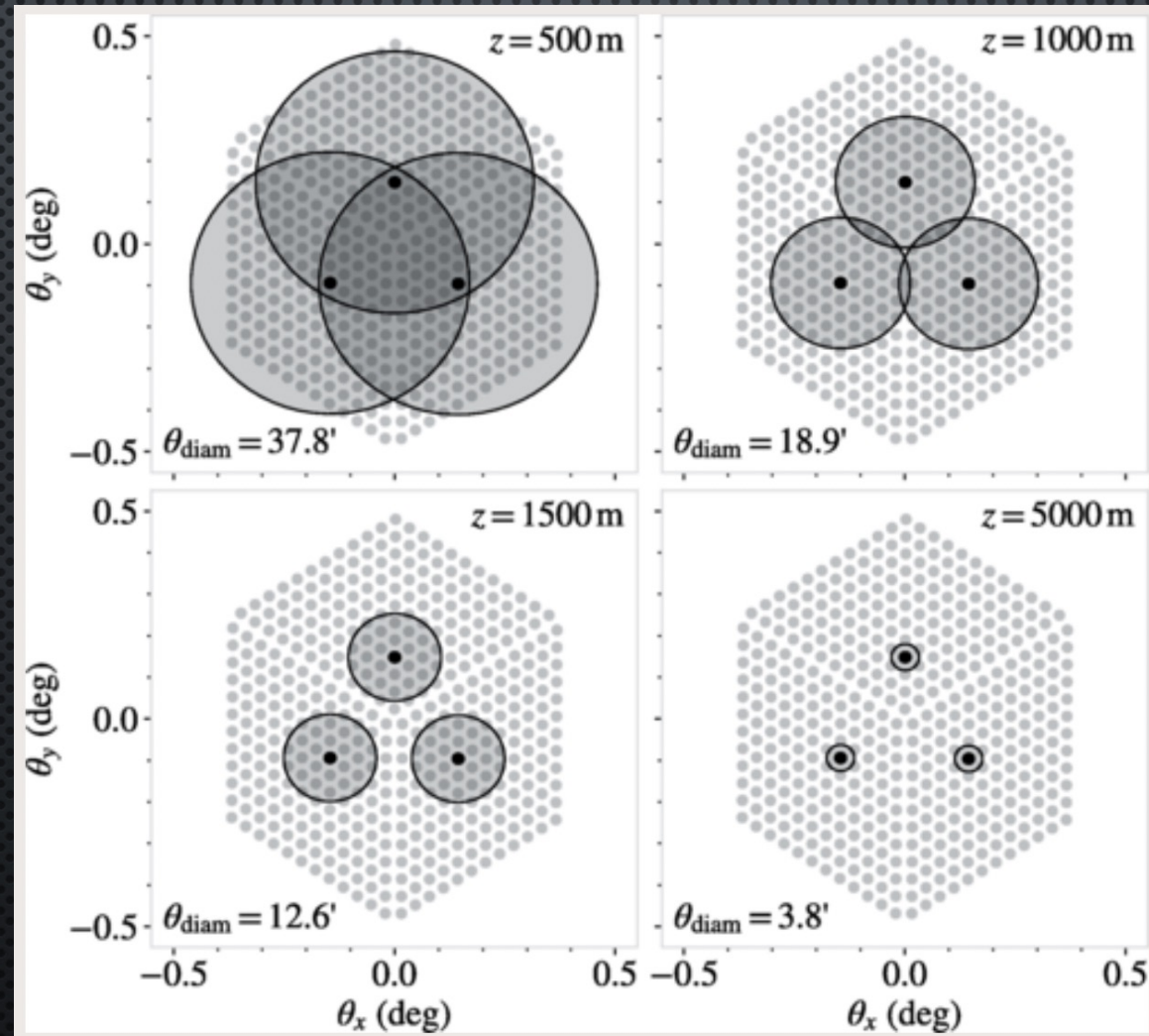
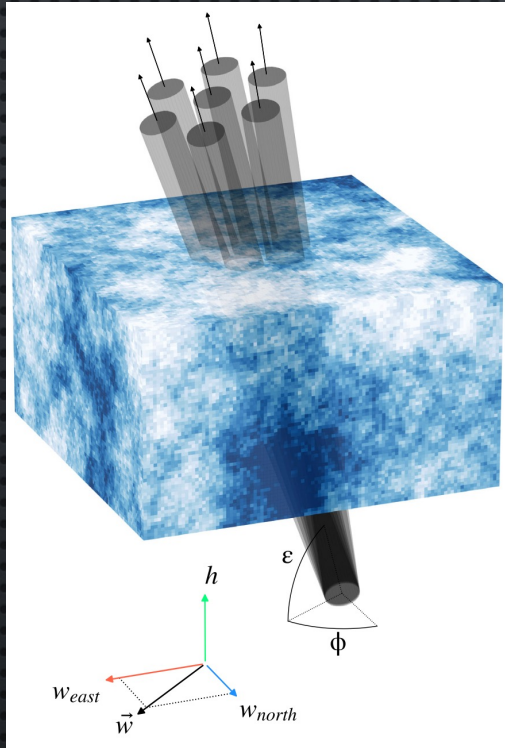

Detectors near each other in the focal plane look through much of the same atmosphere and thus experience correlated noise.

(Note: these effects are also included in the SO forecast noise model shown on the preceding slides.)

ATMOSPHERE & CROSS-LINKING

Real ACT data from four different regions with different crosslinking & scan orientations

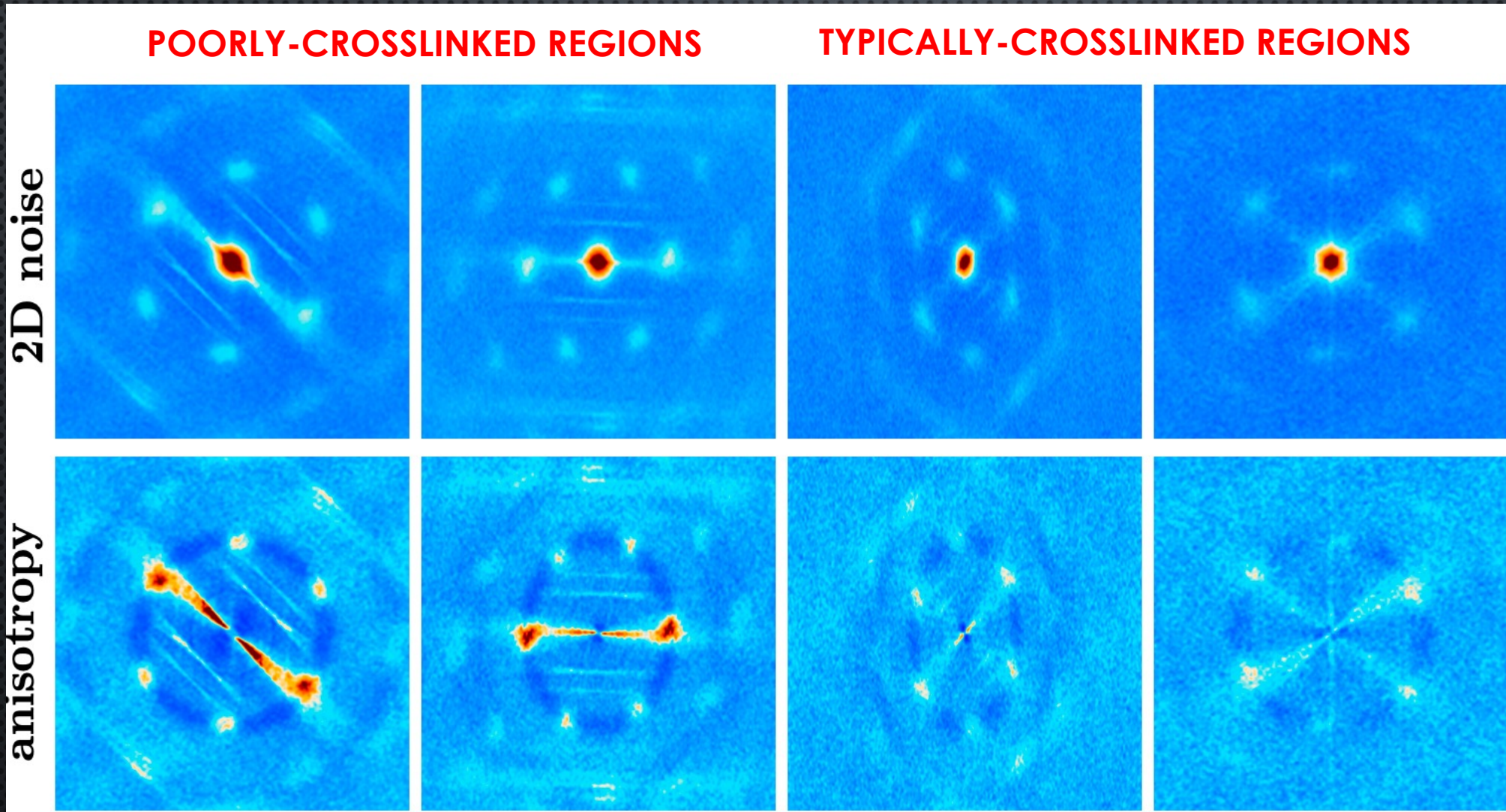

Correlated atmosphere leads to stripes along the scan direction; crosslinking mitigates them.

Lower plots are after removal of a radial average

Near neighbor effects in the detector arrays show up!

ATMOSPHERE. ATMOSPHERE. ATMOSPHERE. ATMOSPHERE.

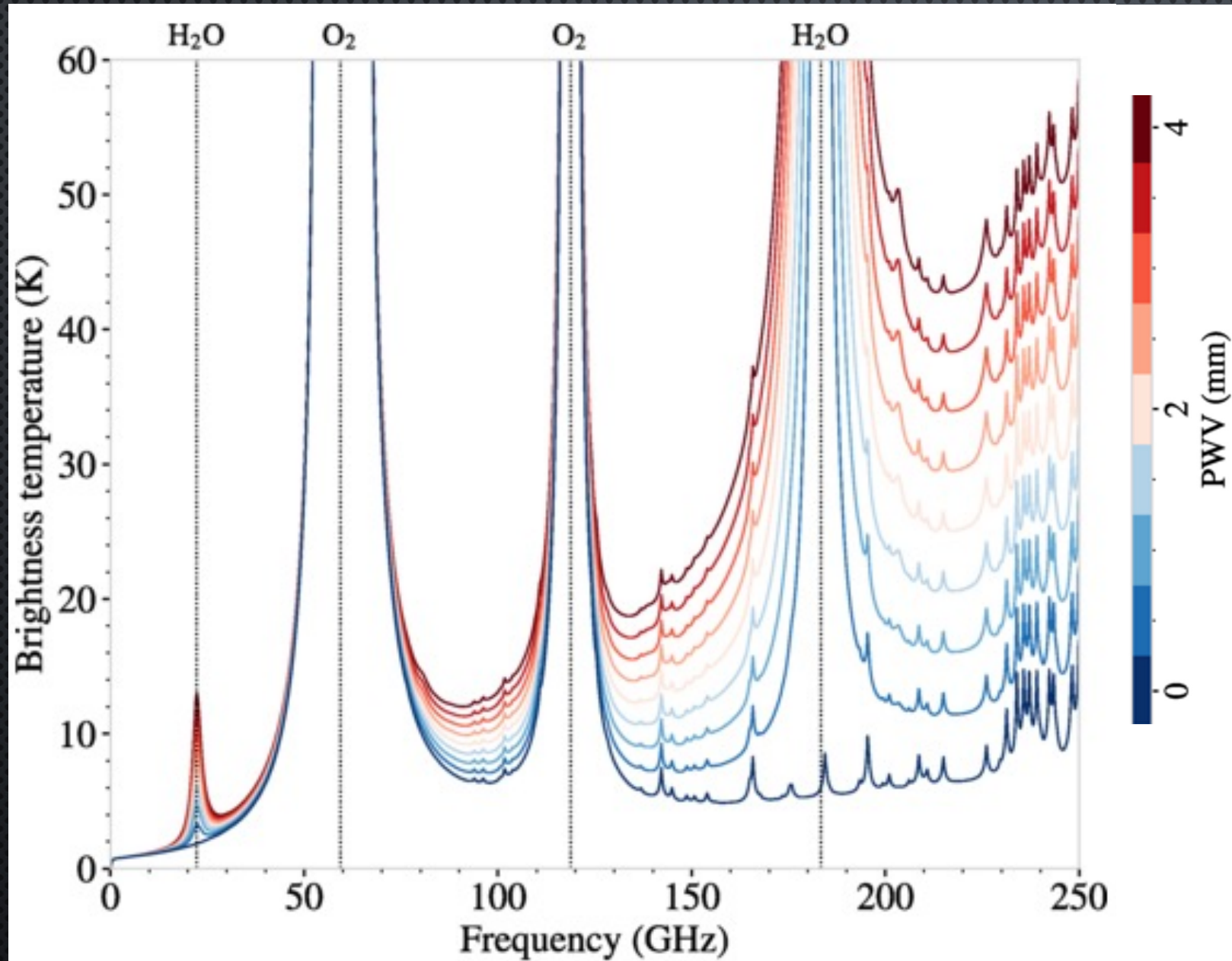

It gets in the way.

And it adds spurious signal.

Extra signal = extra loading.

The signal varies with elevation,

The signal is not constant.

PWV varies with time.

PWV varies with position.

Spectral shape changes,
changing bandpass.

Approach to this: model,
measure, track, correct, null tests,
marginalize.

challenge, *n.*

Forms: *ca.* Middle English–1500s *calenge*, (Middle English *caleng*, 1500s *challenge* ...
Frequency (in current use):
Etymology: Middle English *calenge*, *chalange*, < Old French *ca-*, *challenge*, *-lange*, originally ...

1. An accusation, charge, reproach, objection.

2.
a. The act of calling to account; *esp.* the act of a sentry in demanding the countersign.

b. *Hunting*: The opening and crying of hounds at finding the scent; see CHALLENGE *v.* (In modern dictionaries.)

3. *Law*.
a. 'An Exception taken, against either persons or things' (P^lunt); *spec.* an objection made to one or more of the jurymen in a trial. *cf.* in *principal challenge*, *peremptory challenge*, *challenge of the array*, *challenge to the polls*, *challenge to the favour*. Also, an exception taken to a vote, etc.

b. *East India*. (See quot. 1858.)

4. A calling in question or disputing; the state of being called in question.

5. A claim; the act of demanding as a right. In early use, often, a false claim. *Obsolete*.

6.
a. An invitation or summons to a trial or contest of any kind; a defiance.

b. *In weakened use*: a difficult or demanding task, *esp.* one seen as a test of one's abilities or character.

1954 W. FAULKNER *Fable* 23 'It was not that his trained professional judgment told him that the affair would be touch-and-go and hence more than doubtful, that would have been a challenge, as if the old destiny had not abandoned him at all.'

1957 A. E. SUNDEN *New Amer.* III, iv, 347 'One of tomorrow's great challenges will be to make good use of what will very possibly be a greatly increased leisure.'

1966 *Hockey Coaching* (Hockey Association) 5 'The game of hockey in this country is facing a real challenge.'

1972 E. LINDFORD *Wellington* xlii, 340 'Today the Martyrs' Memorial stands like a rock of tranquillity in the roaring currents of the twentieth century, an occasional challenge to the climbing skills of students, pot in hand.'

1979 D. HALBERSTAM *Powers that Be* (1980) i, ii, 71 'He almost seemed to welcome the challenge of the war, it would test America's worthiness.'

7. *spec.* A summons to fight, *esp.* to single combat or duel.

8. *attributive*.

1813 W. SCOTT *Bridal of Triermain* III, x, 142 'The valiant Knight of Triermain Rung forth his challenge-blast again.'

9. The action or process of administering an immunogenic agent to an animal or person in order to study the resulting immune response, or of exposing an animal or person to an infectious agent, *esp.* to measure the efficacy of a vaccine. Frequently as a modifier, *esp.* in *challenge study*, *challenge trial*. Cf. CHALLENGE *v.* 9.

CHALLENGES

6b. In weakened use: a difficult or demanding task, esp. one seen as a test of one's abilities or character.

Atmosphere

Production Capacity

Access

Problems Not Yet Dreamt Of

CHALLENGE OF ATMOSPHERE → MORE DETECTORS

SO, BICEP Array, CMB-S4, Ali-CPT & others:
detector modules based on 150 mm detector wafers

Then, 100,000 detectors ~ 50-100 modules.

PAROCHIAL EXAMPLE of SO:

PLAN: deploy 49 modules in the next 2 yrs.

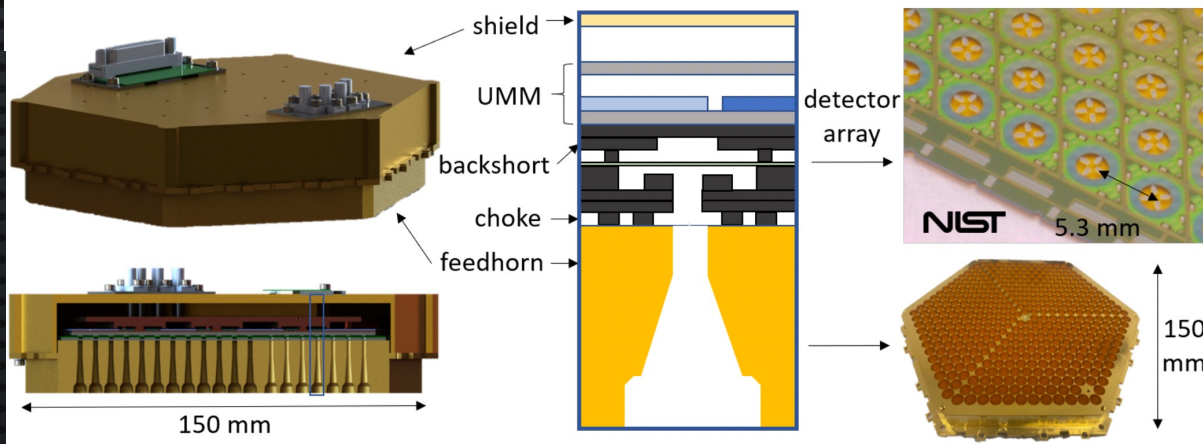

Each module has:

- 1 detector wafer
- 4 optical coupling wafers, aligned & glued
- 1 multi-layer interface ("routing") wafer
- 28 multiplexing chips

- 1 feedhorn array
- 1 high-precision mounting tray

- 1 lid
- 1 magnetic shield
- 2 PCBs, one with imbedded flex & MDM
- 4 coax connections
- Pogo pins, tripod springs, washers, screws

Each module requires:

- Precision gluing of parts (CTE alignments)
- ~ 12,000 aluminum wire bonds
- ~ 100 gold wire bonds
- Pre-assembly screening of most parts
- Two stages of testing at 100 mK

CHALLENGE OF ATMOSPHERE → MORE DETECTORS



Aphorism: Detectors define the critical path for CMB experiments.

Hypothesis: Detector R&D defines the critical path for CMB experiments

Aim: Get past the R&D and move into production mode

Context for Production rates including R&D:

ACT: 10 O(1000) detector modules produced over 15 yrs [0.7/ yr]

SO: 39 O(2000) detector modules (+ 10 O(200) modules) over 5 yrs [8/ yr]

Punchline: Hypothesis looks good so far! CMB-S4 will be the next test.

MORE DETECTORS → HUGE RECEIVERS + HIGH THROUGHPUT PRODUCTION OF OPTICS



SO LAT Receiver
2.4 m dia

Xu et al, 2020; SPIE 11453,
doi:10.1117/12.2576151.

SO LAT holds 13 optics tubes (36-cm)

Each has: 3 AR-coated silicon lenses, 1 AR-coated window, 1 AR-coated alumina filter, and free-space filters

Each SO SAT (42 cm stop) has the same elements + an extra AR-coated alumina filter and an AR-coated sapphire HWP

BICEP ARRAY & CMB-S4 also need many AR-coated optical elements!

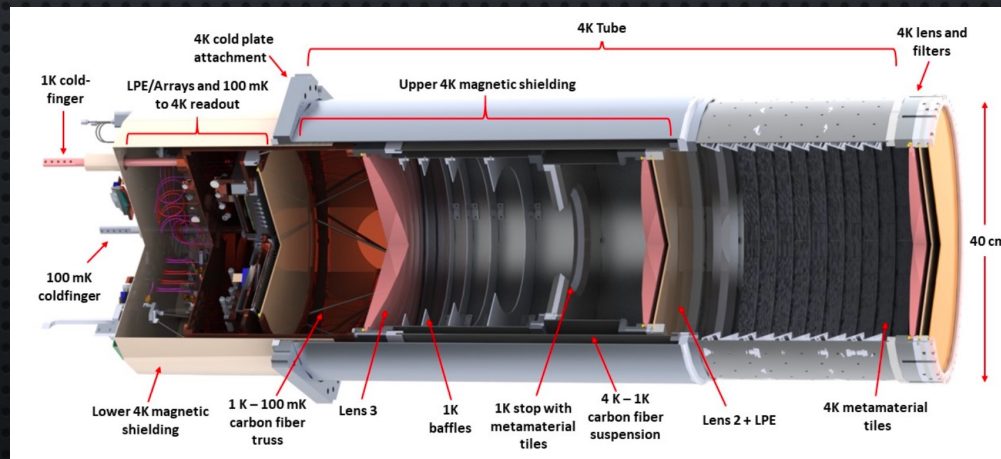

It could be worse
if not for DRs!

DETECTOR SENSITIVITIES: 100 mK & "BACKGROUND LIMITED"

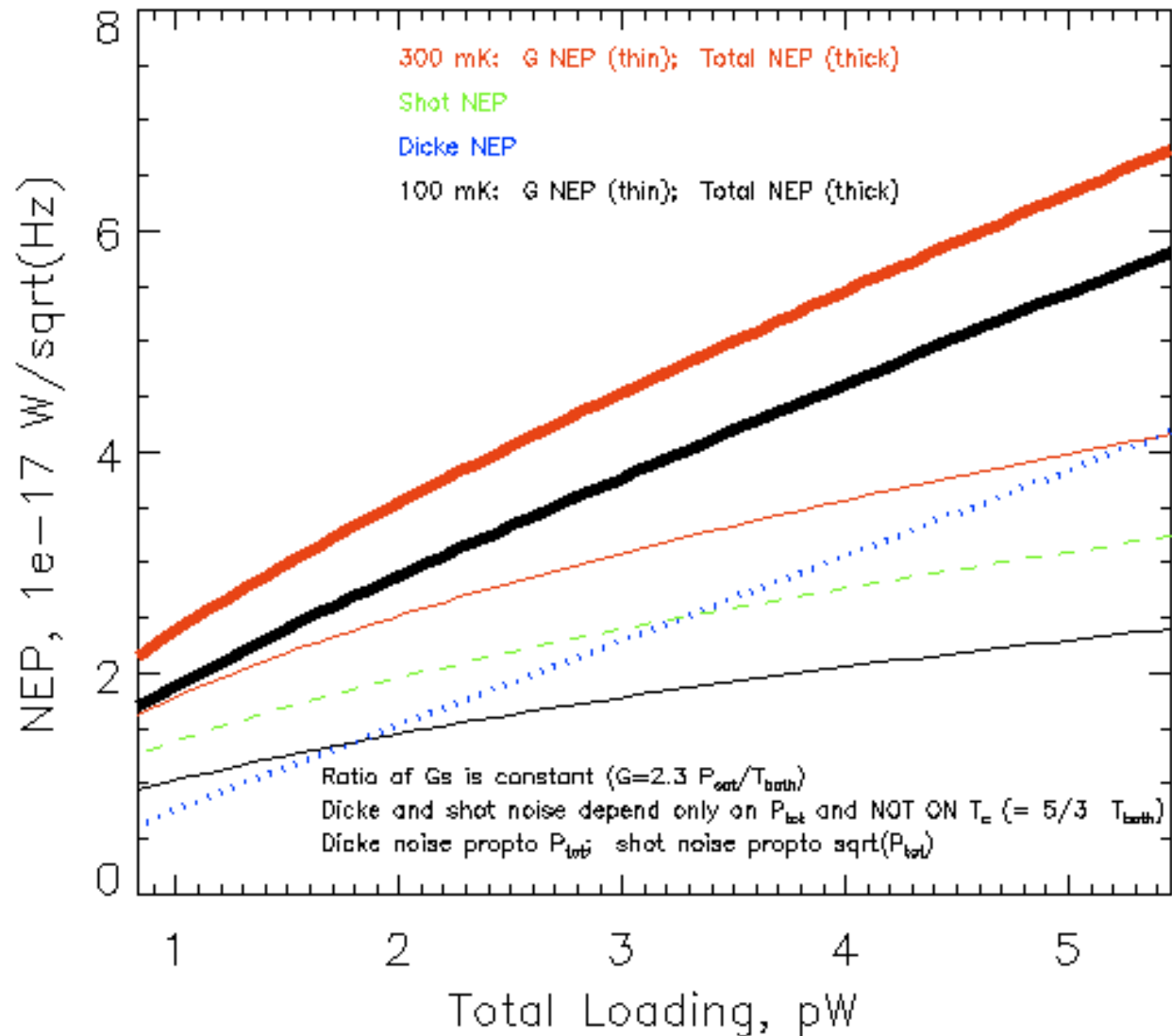

MODERN PULSE-TUBE BACKED DILUTION FRIDGES ARE EASIER TO USE THAN ^3He SYSTEMS (more cooling power – 100-300 μW typical at 100 mK)

We've been running one at 17kft in Chile since 2012.

challenge, *n.*

Forms: *a.* Middle English–1500s *calenge*, (Middle English *caleng*, 1500s *challenge* ...

Frequency (in current use):

Etymology: Middle English *calenge*, *chalance*, < Old French *ca-*, *challenge*, *-lange*, originally ...

1. An accusation, charge, reproach, objection.

2.

a. The act of calling to account; *esp.* the act of a sentry in demanding the countersign.

b. *Hunting.* The opening and crying of hounds at finding the scent; see CHALLENGE *v.* (In modern dictionaries.)

3. *Law.*

a. 'An Exception taken, against either persons or things' (P^lunt); *spec.* an objection made to one or more of the jurymen in a trial. *cf.* in *principal challenge*, *peremptory challenge*, *challenge of the array*, *challenge to the polls*, *challenge to the favour*. Also, an exception taken to a vote, etc.

b. *East India.* (See quot. 1858.)

4. A calling in question or disputing; the state of being called in question.

5. A claim; the act of demanding as a right. In early use, often, a false claim. *Obsolete.*

6.

a. An invitation or summons to a trial or contest of any kind; a defiance.

b. In weakened use: a difficult or demanding task, esp. one seen as a test of one's abilities or character.

1954 W. FAULKNER *Fable* 23 'It was not that his trained professional judgment told him that the affair would be touch-and-go and hence more than doubtful, that would have been a challenge, as if the old destiny had not abandoned him at all.'

1957 A. E. SIVENSON *New Amer.* III, iv, 347 'One of tomorrow's great challenges will be to make good use of what will very possibly be a greatly increased leisure.'

1966 *Hockey Coaching* (Hockey Association) 5 'The game of hockey in this country is facing a real challenge.'

1972 E. LINDFORD *Wellington* xlii, 340 'Today the Martyrs' Memorial stands like a rock of tranquillity in the roaring currents of the twentieth century, an occasional challenge to the climbing skills of students, pot in hand.'

1979 D. HALBERSTAM *Powers that Be* (1980) i, ii, 71 'He almost seemed to welcome the challenge of the war, it would test America's worthiness.'

7. *spec.* A summons to fight, *esp.* to single combat or duel.

8. *attributive.*

1813 W. SCOTT *Bridal of Triermain* II, x, 142 'The valiant Knight of Triermain Rung forth his challenge-blast again.'

9. The action or process of administering an immunogenic agent to an animal or person in order to study the resulting immune response, or of exposing an animal or person to an infectious agent, *esp.* to measure the efficacy of a vaccine. Frequently as a modifier, *esp.* in *challenge study*, *challenge trial*. Cf. CHALLENGE *v.* 9.

CHALLENGES

6b. In weakened use: a difficult or demanding task, esp. one seen as a test of one's abilities or character.

Atmosphere
Production Capacity
Access
Problems Not Yet Dreamt Of

CHALLENGE OF ATMOSPHERE → SPECIFIC SITES



Great for observations but remote and with complicated stakeholder situations

- Remote → off the grid
 - Diesel is not cheap nor particularly green
 - Expanding power supply requires civil construction not just \$\$ to the electric company
 - Access for personnel
 - South Pole – (only a) small on-site team has good year-round access to instrument
 - Chile – easy year-round access for entire team, but the instrument site itself is not always accessible
- Distributed workforce
- Safety, communications, hiring, shipping

Challenge: a difficult or demanding task, esp. one seen as a test of one's abilities or character

JUST DO IT.

Fall down seven times, get up eight.

ACCESS

One possible advantage of ground-based instruments may be the ability to use artificial polarized sources to calibrate polarization angles

Another advantage (though necessary) is there are no weight limitations for shielding the telescope.

The 6m ACT has a co-moving shield as well as an 11 m fixed shield.

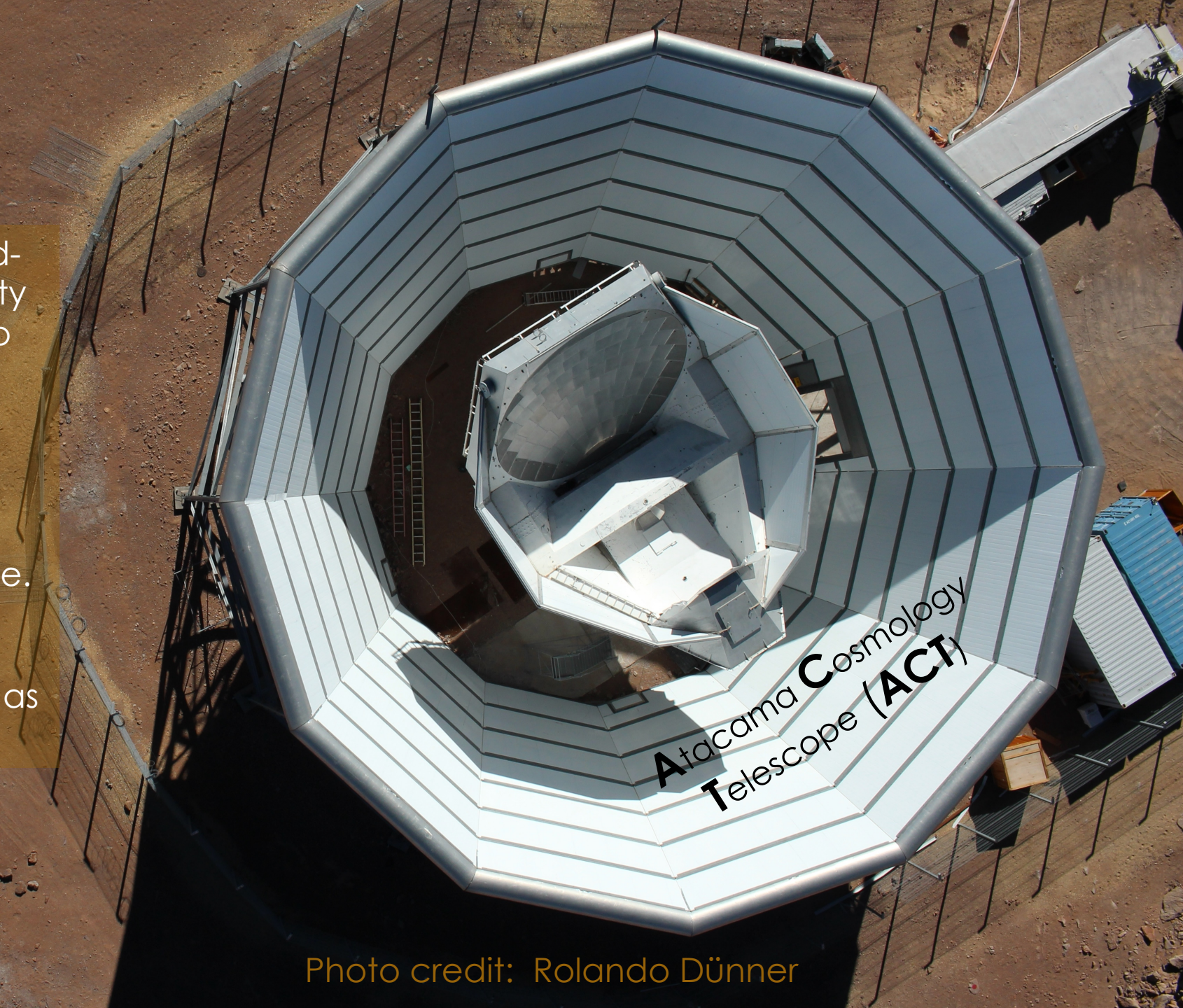
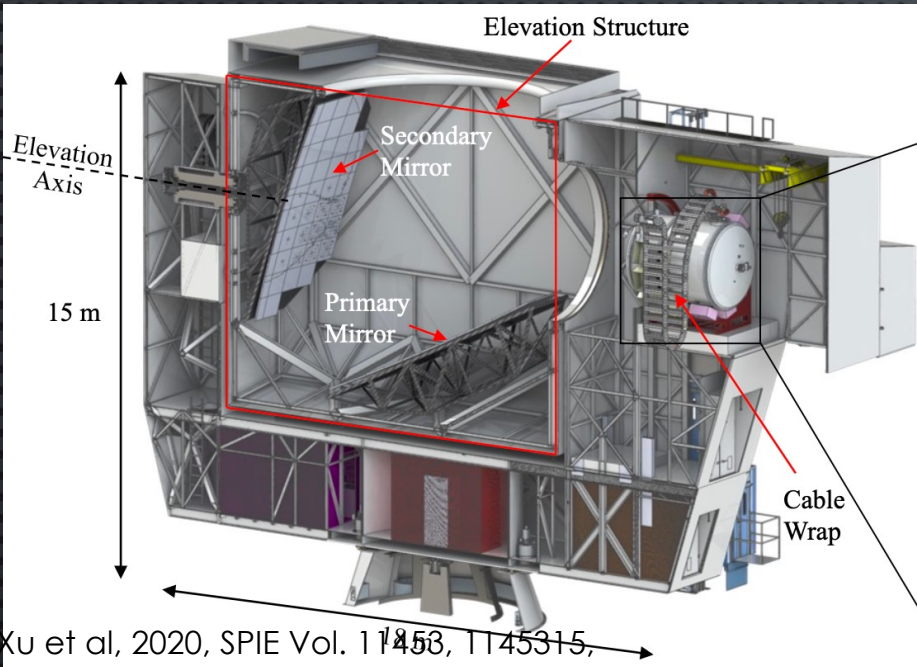

Photo credit: Rolando Dünner

EXAMPLES OF DEFENDING AGAINST GROUND PICKUP FOR FUTURE GROUND-BASED EXPERIMENTS



BICEP ARRAY in its large ground screen



SO Small Aperture Telescopes inside their large ground screens

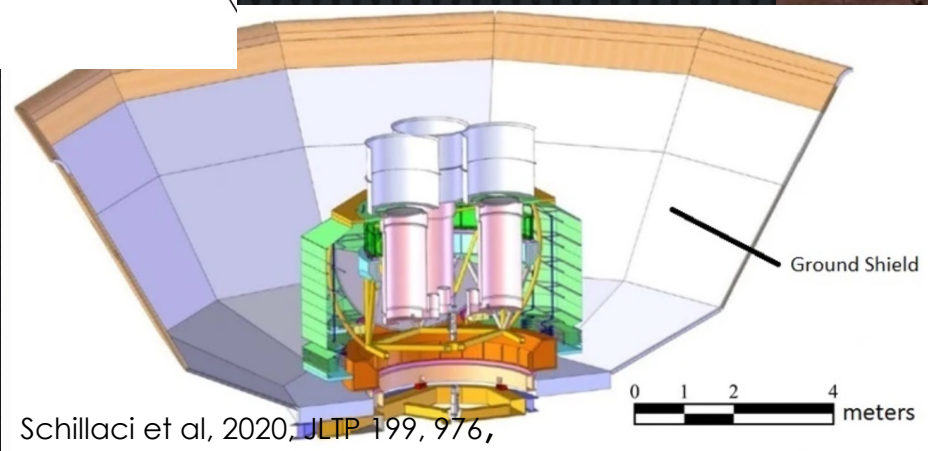

SO Large Aperture Telescope (LAT); same design for CCAT & CMB-S4

challenge, *n.*

Forms: *a.* Middle English–1500s *calenge*, (Middle English *caleng*, 1500s *challenge* ...

Frequency (in current use):

Etymology: Middle English *calenge*, *chalange*, < Old French *ca-*, *challenge*, *-lange*, originally ...

1. An accusation, charge, reproach, objection.

2.

a. The act of calling to account; *esp.* the act of a sentry in demanding the countersign.

b. *Hunting.* The opening and crying of hounds at finding the scent; see CHALLENGE *v.* (In modern dictionaries.)

3. *Law.*

a. 'An Exception taken, against either persons or things' (P^lunt); *spec.* an objection made to one or more of the jurymen in a trial, as in *principal challenge*, *peremptory challenge*, *challenge to the array*, *challenge to the polls*, *challenge to the favour*. Also, an exception taken to a vote, etc.

b. *East India.* (See quot. 1858.)

4. A calling in question or disputing; the state of being called in question.

5. A claim; the act of demanding as a right. In early use, often, a false claim. *Obsolete.*

6.

a. An invitation or summons to a trial or contest of any kind; a defiance.

b. In weakened use: a difficult or demanding task, esp. one seen as a test of one's abilities or character.

1954 W. FAULKNER *Fable* 23 It was not that his trained professional judgment told him that the affair would be touch-and-go and hence more than doubtful, that would have been a challenge, as if the old destiny had not abandoned him at all.

1957 A. E. STEVENSON *New Amer.* III, IV, 347 One of tomorrow's great challenges will be to make good use of what will very possibly be a greatly increased leisure.

1966 *Hockey Coaching* (Hockey Association) 5 The game of hockey in this country is facing a real challenge.

1972 E. LINDFORD *Wellington* xlii, 340 Today the Martyrs' Memorial stands like a rock of tranquillity in the roaring currents of the twentieth century, an occasional challenge to the climbing skills of students, put in hand.

1979 D. HALBERSTAM *Powers that Be* (1980) I, II, 71 He almost seemed to welcome the challenge of the war, it would test America's worthiness.

7. *spec.* A summons to fight, *esp.* to single combat or duel.

8. *attributive.*

1813 W. SCOTT *Bridal of Triermain* III, X, 142 The valiant Knight of Triermain Rung forth his challenge-blast again.

9. The action or process of administering an immunogenic agent to an animal or person in order to study the resulting immune response, or of exposing an animal or person to an infectious agent, *esp.* to measure the efficacy of a vaccine. Frequently as a modifier, *esp.* in *challenge study*, *challenge trial*. Cf. CHALLENGE *v.* 9.

CHALLENGES

6b. In weakened use: a difficult or demanding task, esp. one seen as a test of one's abilities or character.

Atmosphere
Production Capacity
Access
Problems Not Yet Dreamt Of

SURPRISE CHALLENGES: AN EXAMPLE

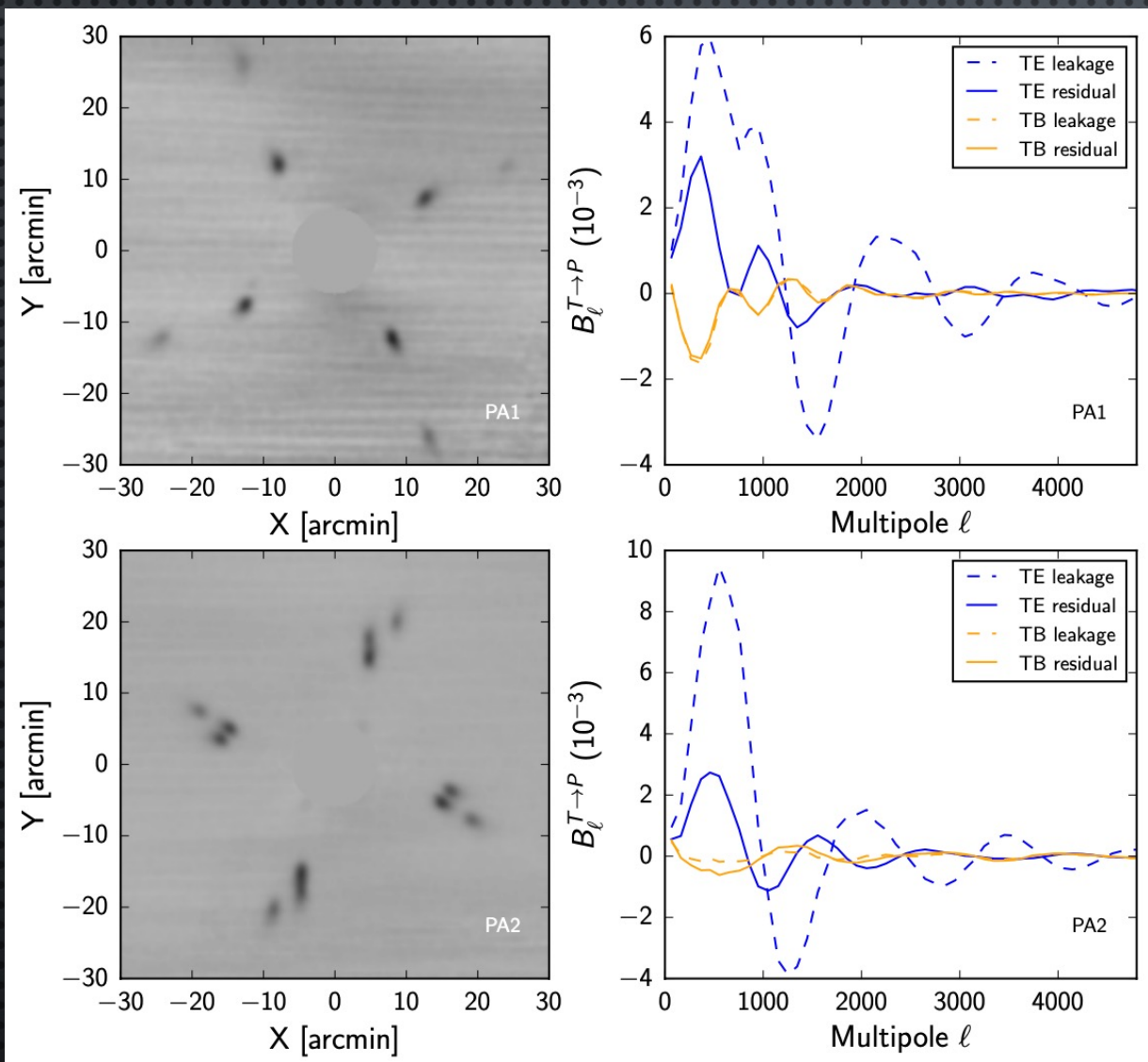

Polarized sidelobe structure
in the ACTPol receiver

SURPRISE CHALLENGES: AN EXAMPLE

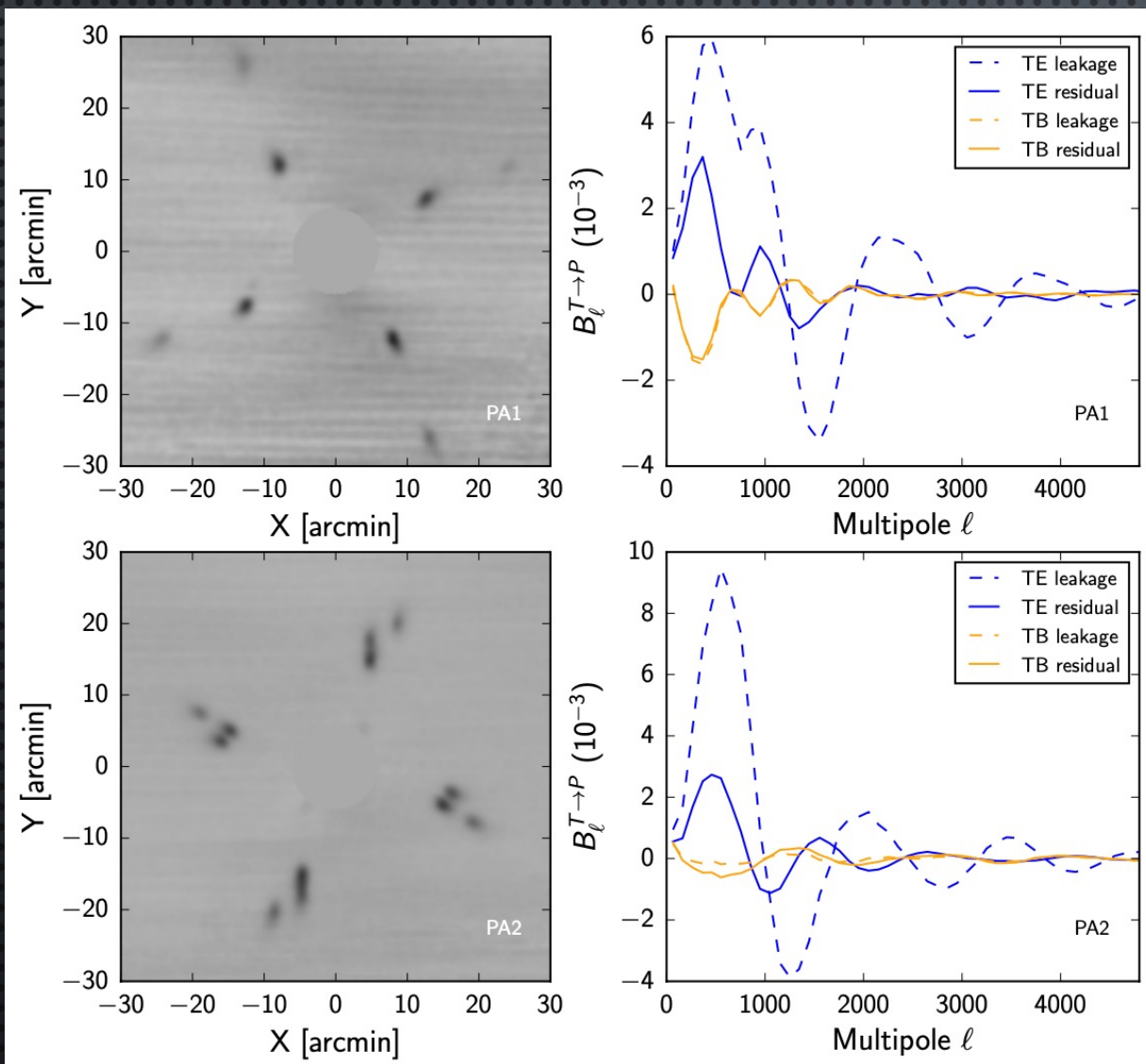

Polarized sidelobe structure in the ACTPol receiver

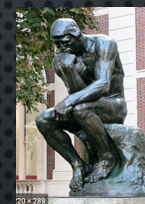

Fall down seven times, get up eight.

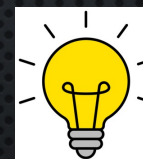

JUST DO IT.

BONUS CHALLENGE

Time domain!

Requires new methods for making data real-time usable by big audience

Makes you want to do an even better job at flux calibration

Related bonus: when you have lots of area and small beams and lots of sensitivity you see sources in most of your TODs – you can measure the beam right out of the maps! Not too many are polarized though.

MANY THANKS TO THE SO AND ACT COLLABORATIONS



I look forward to rising to quite a few challenges with y'all in the years ahead!

