

Crilin: crystal calorimeter with longitudinal information

E. Diociaiuti, A. Saputi, **I. Sarra** – Laboratori Nazionali di Frascati
D. Tagnani – INFN Sezione di Roma3
D. Paesani – INFN Sezione di Bari
D. Lucchesi, L. Sestini – INFN Sezione di Padova
N. Pastrone – INFN Sezione di Torino

8 June 2021

Meeting con referees



CRILIN

the semi-homogeneous crystal calorimeter

Introduction

- Modern tracking systems are very precise, therefore, in particle flow-like reconstruction algorithms, the jet performance is usually limited by the calorimeter.
- In particular, a high granularity is required in order to distinguish signal particles from the background and to solve the substructures necessary for jet identification.
- In a Muon Collider, the timing could be used to remove signals produced by beam-induced background, asynchronous with respect to the bunch crossing. The calorimeter energy resolution is also fundamental to measure the kinematic properties of jets.
- A finely segmented calorimeter design should be favored in order to solve the jet substructure. **However, this contrasts with the requirement for high timing resolution even for signal events involving low energy deposits, such as in the case of high impulse muons.**

Beam Induced Background

- The distributions of the energy released in ECAL by the beam-induced background (BIB) and signals (i.e. prompt muons) are different;
- The BIB must be subtracted in the proper way to reconstruct the muon tracks;
- The longitudinal measurement can be exploited to perform the subtraction.

Energy released in ECAL barrel by one BIB bunch crossing

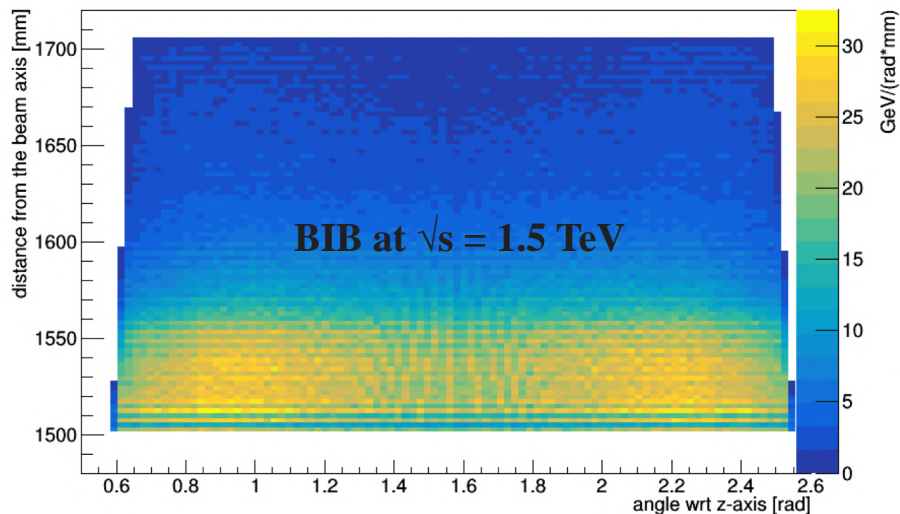

Energy released in ECAL barrel by uniformly distributed prompt muons in the (θ, ϕ) space

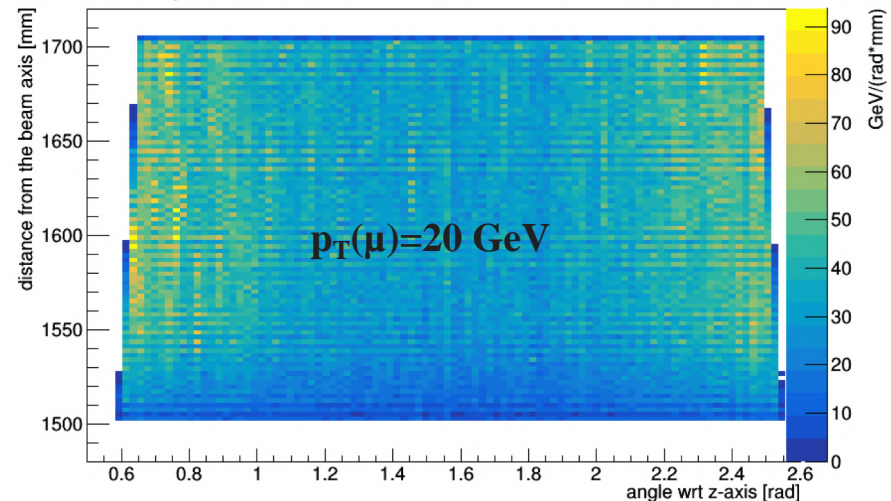

Beam Induced Background -2-

- The BIB produces most of the hits in the first layers of the calorimeter;
- I.e. muons produce a constant density of hits after the first calorimeter layers.
- The BIB hits in the calorimeter are out-of-time wrt the bunch crossing;
- A measurement of the hit time performed cell-by-cell can be used to remove most of the BIB.

hit longitudinal coordinate distribution

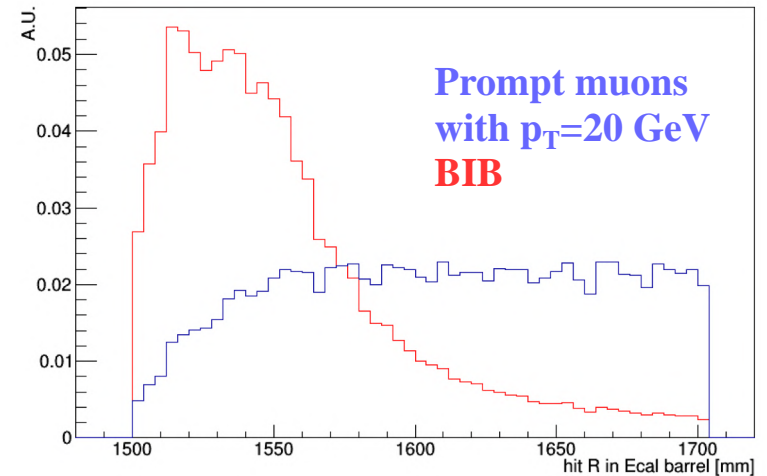

hit time distribution (t_0 is the time of arrival of prompt photons)

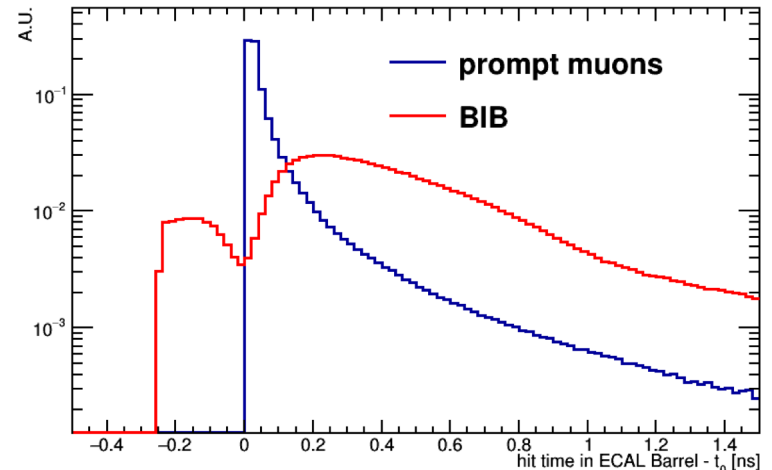

A Crystal Calorimeter with Longitudinal information

- The proposed R&D has the goal to build a crystals calorimeter, fast, relative cheap, and with a granularity (both transversal that longitudinal) tuned on MC observations.
- The Crilin calorimeter is a semi-homogeneous calorimeter based on Lead Fluoride (PbF_2) Crystals readout by surface mounted UV extended Silicon Photomultipliers (SiPMs).

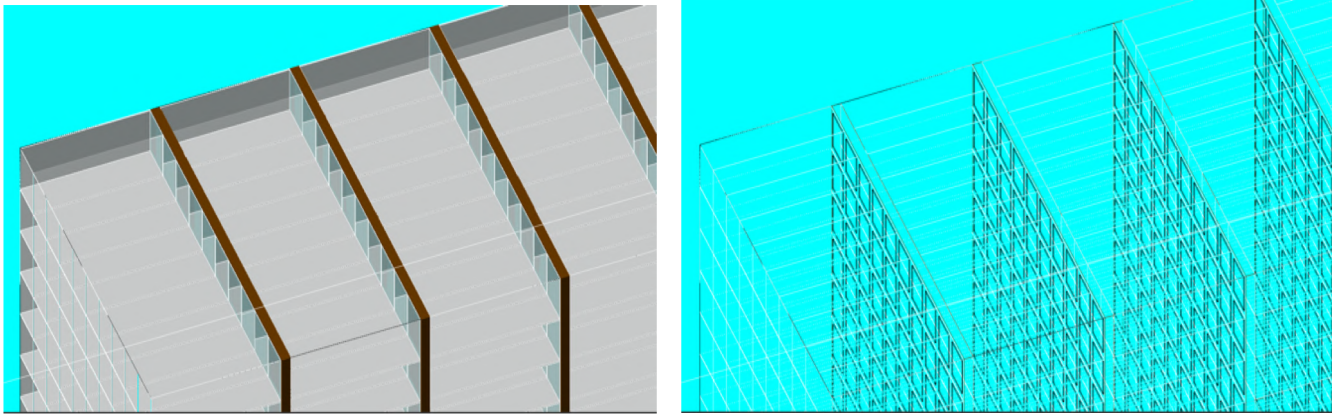

- The Crilin R&D proposal embeds a modular architecture based on stackable submodules composed of matrices of PbF_2 crystals, where each crystal is individually readout by 2 series of 2 UV-extended surface mount SiPMs each.
- Crystal dimensions are $10 \times 10 \times 40 \text{ mm}^3$ and the surface area of each SiPM is $4 \times 4 \text{ mm}^2$, to closely match the crystal surface.

A Crystal Calorimeter with Longitudinal information

- The essential advantage of this choice consists in the excellent compromise of 5 requirements:
 1. high response speed (the Cherenkov response of PbF_2 is instantaneous with respect to the particle passage);
 2. reduced signal width and therefore an excellent ability to resolve temporally close events at high rate (good pileup capability);
 3. a good light collection enables a good energy resolution throughout the whole dynamic range;
 4. good resistance to radiation;
 5. fine granularity and scalable SiPMs pixel dimensions.
- The test and results shown in the following have been obtained with PbF_2 crystals by SICCAS and S14160-4050HS SiPMs by Hamamatsu.

Energy Deposits

- The extremely high granularity allows a maximum energy deposit per crystal in the order of 3-5 GeV per event, which corresponds to the simulated deposit of 30 GeV π^0 events;
- At the same time, the Light Yield (LY) should be high enough to enable a good measurement of the energy deposited by the passage of high-momentum muons, which - according to our simulations - should correspond to a deposit of 30-40 MeV per crystal.
- In this regard, the choice of 50 μm pixels would guarantee an excellent linearity in the response.

Average of the energy deposited by one thousand 30 GeV π^0 (left) and one thousand μ^- (right) in each of the modules (5 modules with crystals of 4 cm length in this example)

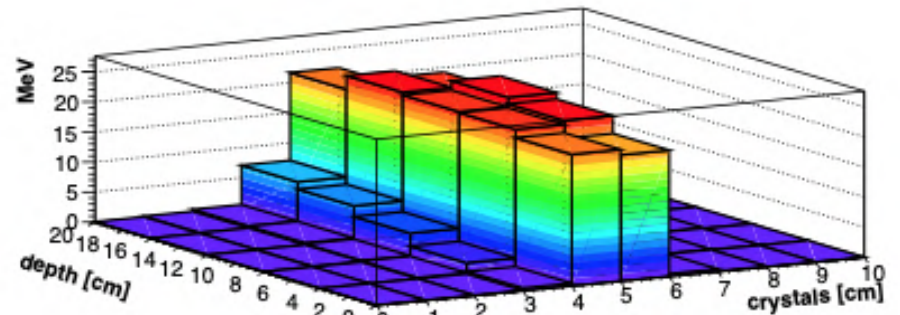
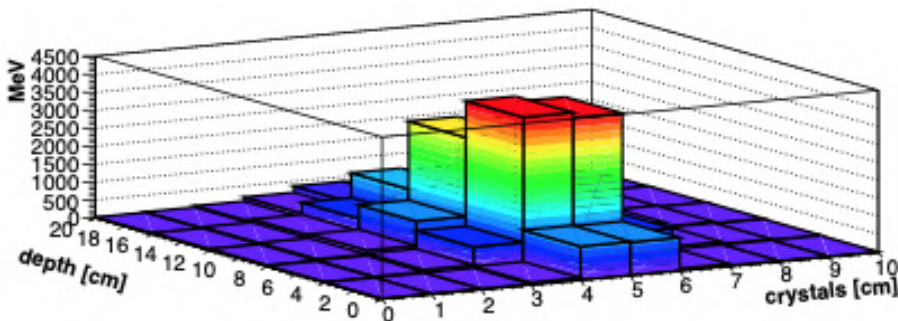

Simulation of the experiment

- Lorenzo has implemented Crilin in the simulation and replaced the old ECAL barrel.
- **Finished to simulate an entire BIB event running through the calorimeter --> studies in progress.**

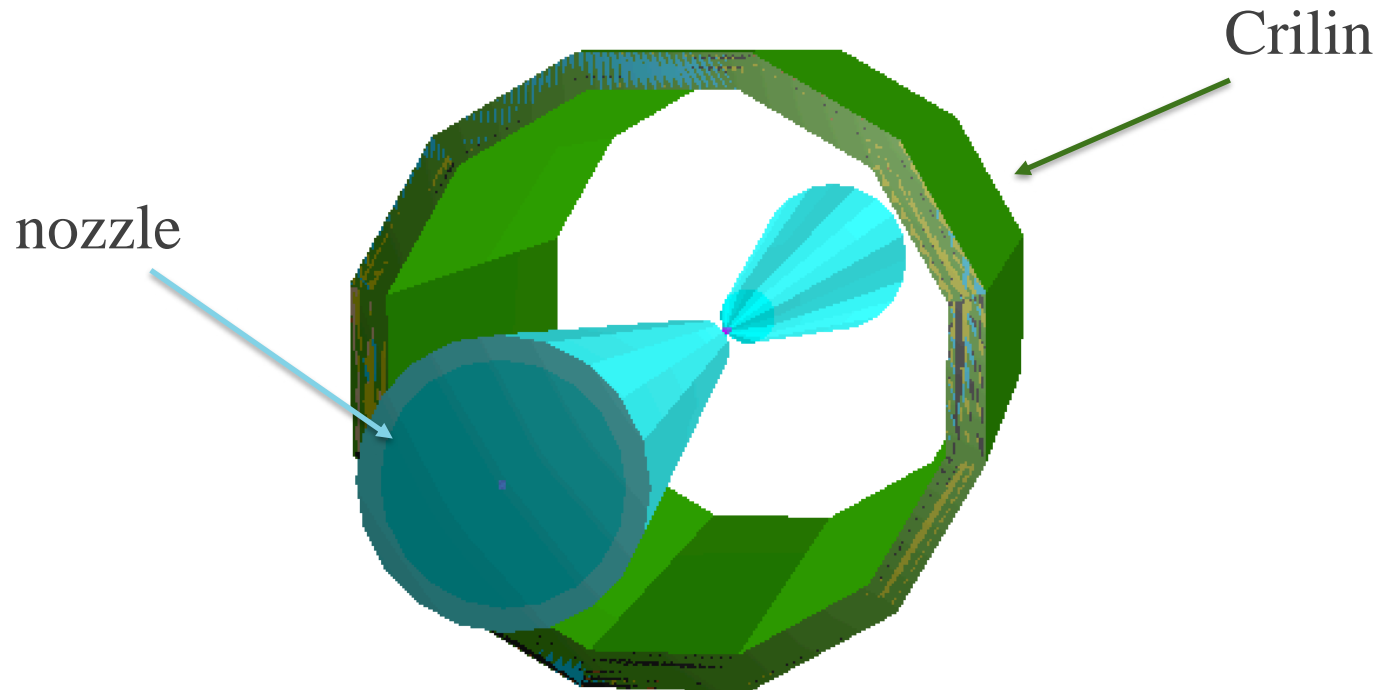

Radiation Environment and radiation damage

- In the case of a future Muon Collider, the requirements relative to the barrel electromagnetic calorimeter (EMC) involve a 1 Mrad total ionizing dose (TID) and a 10^{12} n1MeV/cm² equivalent neutron fluence for the innermost layer.

With regards to Total Ionising Dose (TID) effects, the radiation hardness of PbF₂ was evaluated:

- Two crystals were used to evaluate PbF₂ radiation hardness, by comparing their transmittance before and after irradiation with either photons or neutrons.
- These crystals have been acquired with the same production of the Crilin crystals, to be sacrificed with irradiation tests.
- The first crystal was tested without any kind of wrapping (in the following it will be referred to as the “naked” one), while the second one was wrapped with 100 um Mylar.
- Irradiation phase was started in Calliope, a pool-type gamma irradiation facility equipped with a ⁶⁰Co radio-isotopic source.

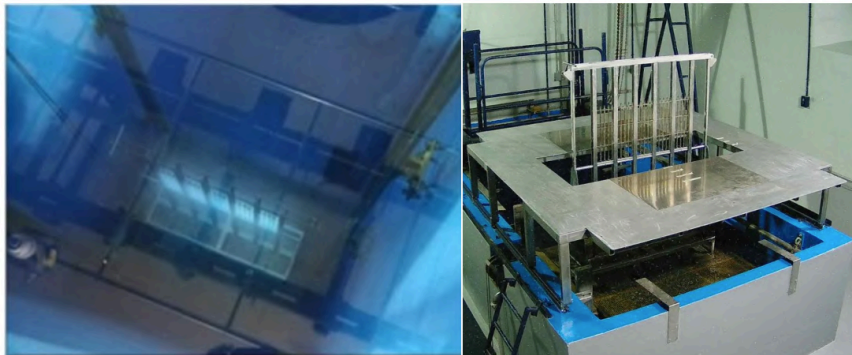

Test crystals:
40 mm length,
with 5x5 mm²
square faces

Total Ionising Dose (TID) on Crystals

- Longitudinal transmission at different steps of irradiation for “naked” crystal (left) and mylar-wrapped crystal (right).

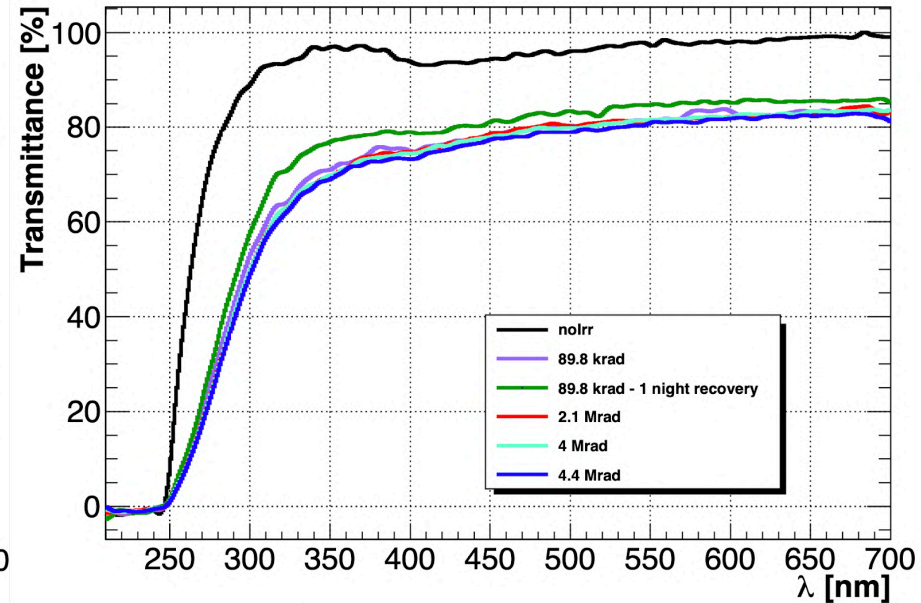
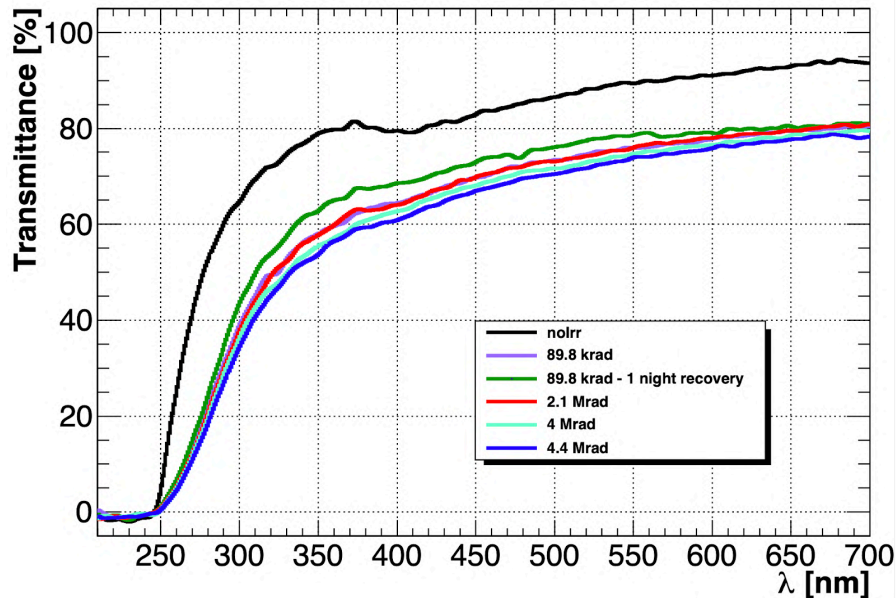

- After a 30 krad dose exposure, an important deterioration in transmittance can be seen for wavelengths below 300 nm, along with an almost constant 25% drop for wavelengths above 300 nm. A transmission recovery of ~10% is observed at 350 nm after one day of natural annealing in the dark. Moreover,
- The transmission deterioration is negligible after 2 Mrad of absorbed dose, indicating a saturation effect associated with the damage mechanism.

Total Ionising Dose (TID) on Crystals - 2 -

- A transmission recovery of ~15% is observed above 300 nm after 18 days of natural annealing since irradiation.

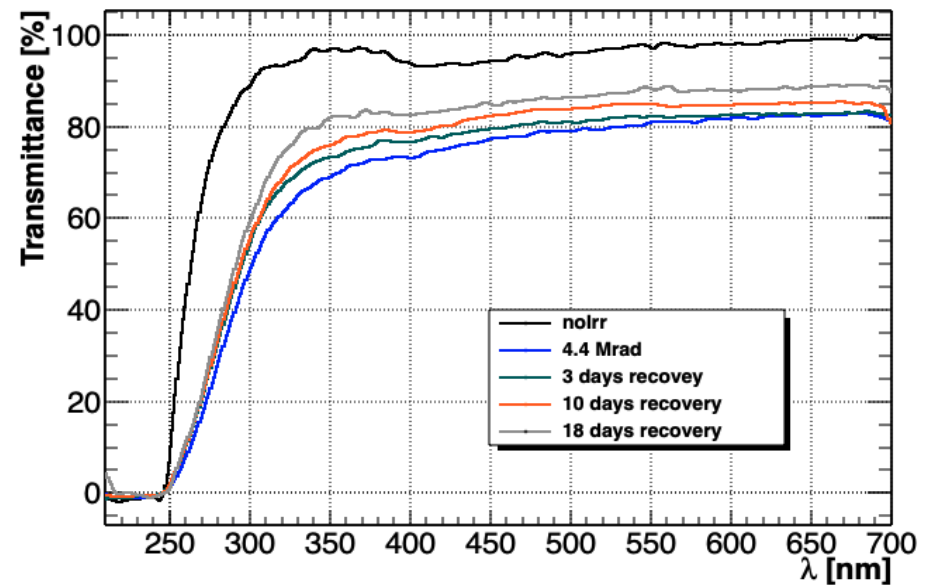
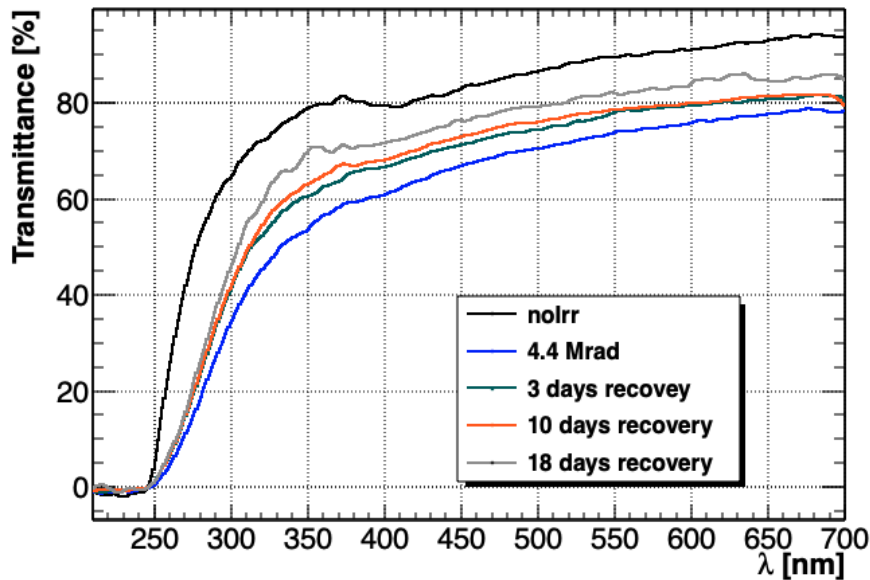

- To further improve the recovery process, a light-bleaching test on the crystals with 400 nm blue light has been done.
- After 16 hours of optical bleaching, a modest recovery of a few percent on the transmittance spectrum was observed, indicating a small accelerating effect on the recovery process with respect to previously described natural annealing.

Neutron Flux (NIEL) on Crystals and SiPMs

- Neutron generation at FNG is based on the $T(d,n)\alpha$ fusion reaction, to produce 14 MeV neutrons with a flux up to $\sim 10^{10}$ neutrons/s in steady state or pulse mode.
- The crystals were placed at 1 cm from the source with the SiPM positioned on the back face, obtaining a neutron flux on the front face of the crystals of 10^{13} $n_{1\text{MeV eq.}} / \text{cm}^2$ and $\sim 5 \times 10^{11}$ for the SiPMs.

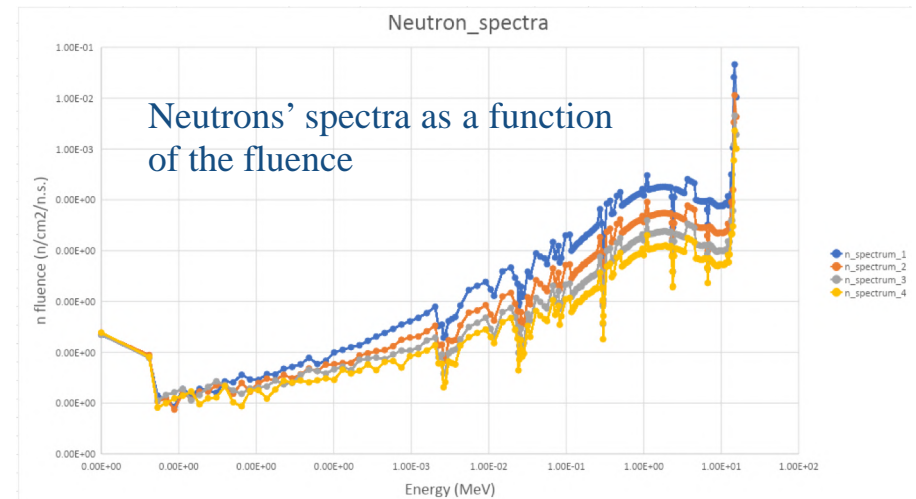
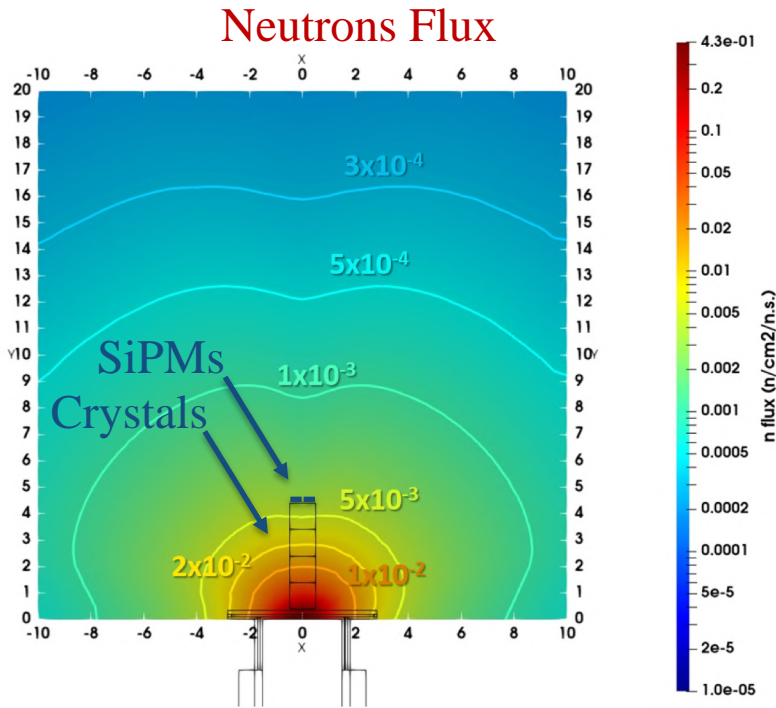

Neutron Flux (NIEL) on Crystals

- After irradiation, crystals have been shipped to Enea Casaccia to measure the transmittance again.
- A high reduction of the transmittance below 400 nm is observed; an almost constant 10 percent reduction is observed above 400 nm

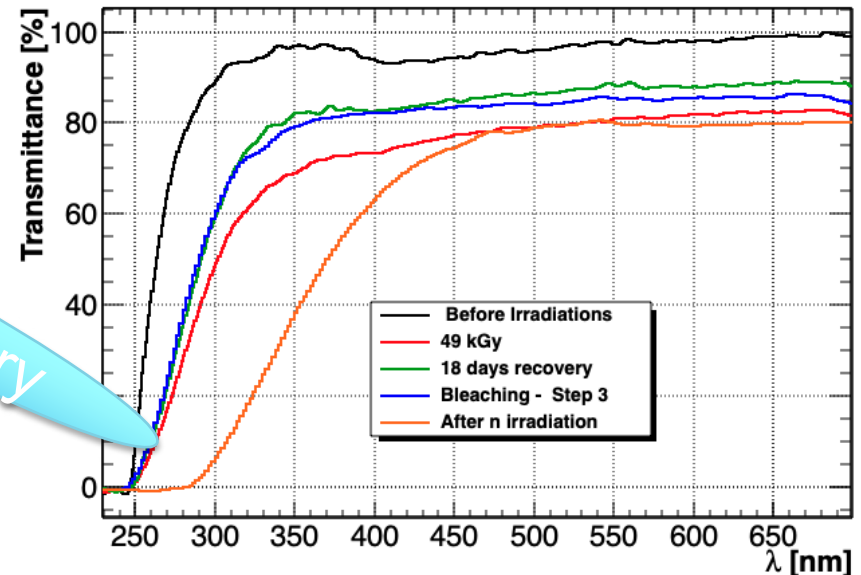
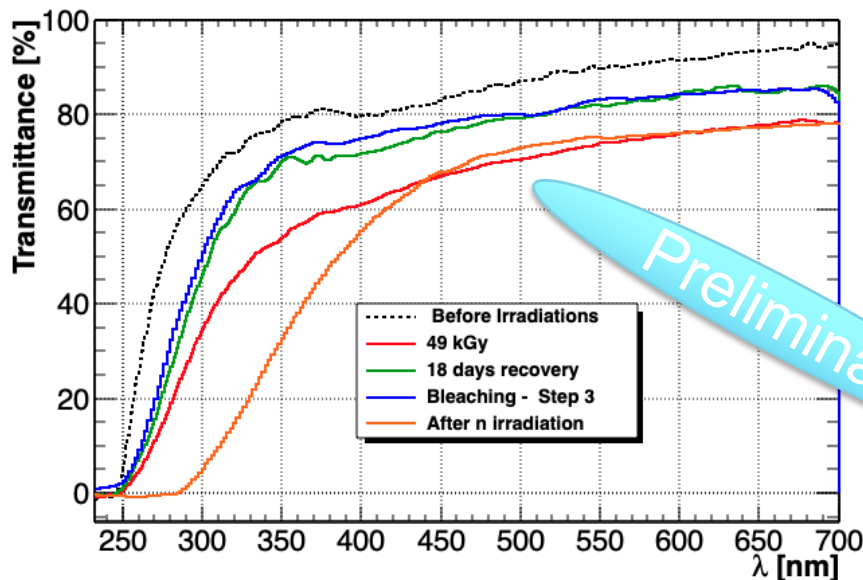

Preliminary

With dedicated transversal studies of the transmittance we will evaluate if the damage is considerably constant along the 4 cm crystal or, as expected, mainly localized in the first centimetres of the front face.

Neutron Flux (NIEL) on SiPMs

- The main SiPMs damage due to the irradiation with neutrons is related to the increase of the dark current.
- The ratio between the dark current, after and before the irradiation with 5×10^{11} n/cm² 1 MeV eq. on SiPMs is $11 \text{ mA} / 2 \text{ uA} = 6000$, evaluated at the nominal bias (41.35 Volt per SiPM, 82.7 Volt per series).
- **The expected leakage current operating at 0° C is less than 1 mA per series, compatible with our mechanical and electrical designs.**

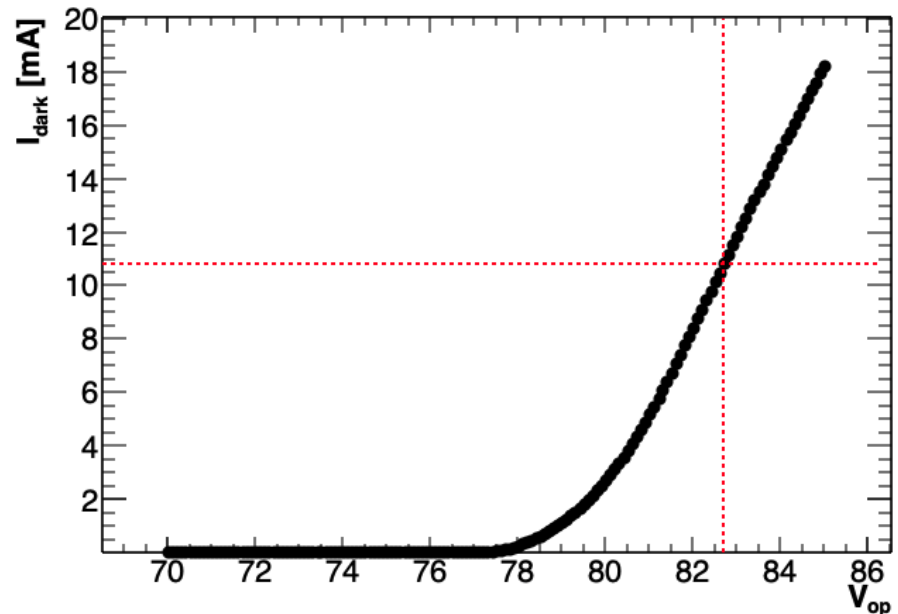

First Test on a single Crystal with Cosmic Rays

- In order to carry out a preliminary evaluation of the Light Yield, the energy response of PbF2 to cosmic rays was measured using a single crystal (10x10x40 mm³), optically coupled - by means of UV clear optical grease - with two 4x4 mm² SiPMs in a series configuration.
- With a test amplifier (Gain=250), we have evaluated the response to cosmic rays in a self triggering mode:
 - measuring the charge relative to 1 p.e.

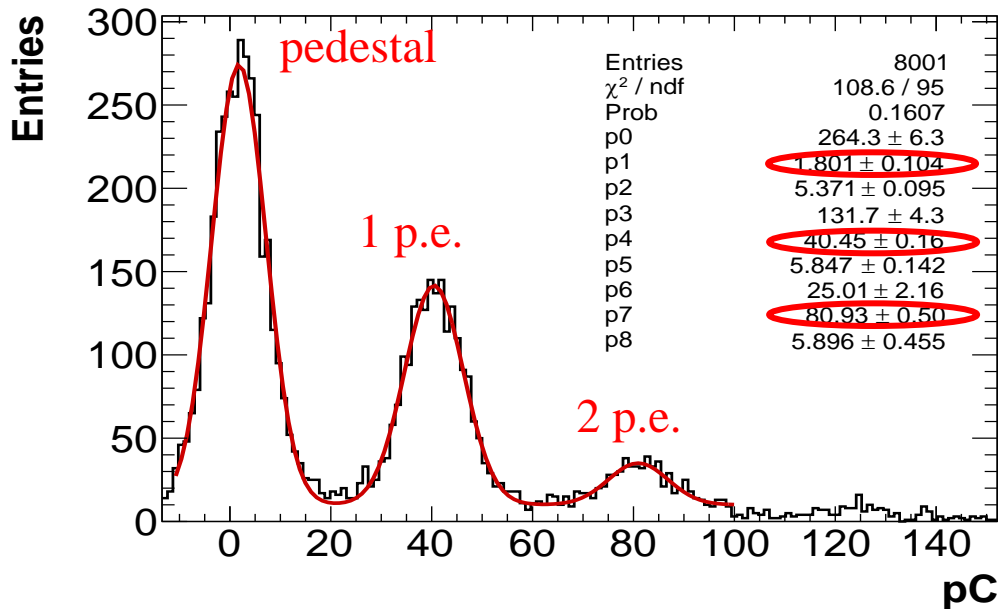

First Test on a single Crystal with Cosmic Rays

- We can use this value to scale the Minimum Ionizing Particles (MIP) charge response and thus determine the relative number of photo-electrons.

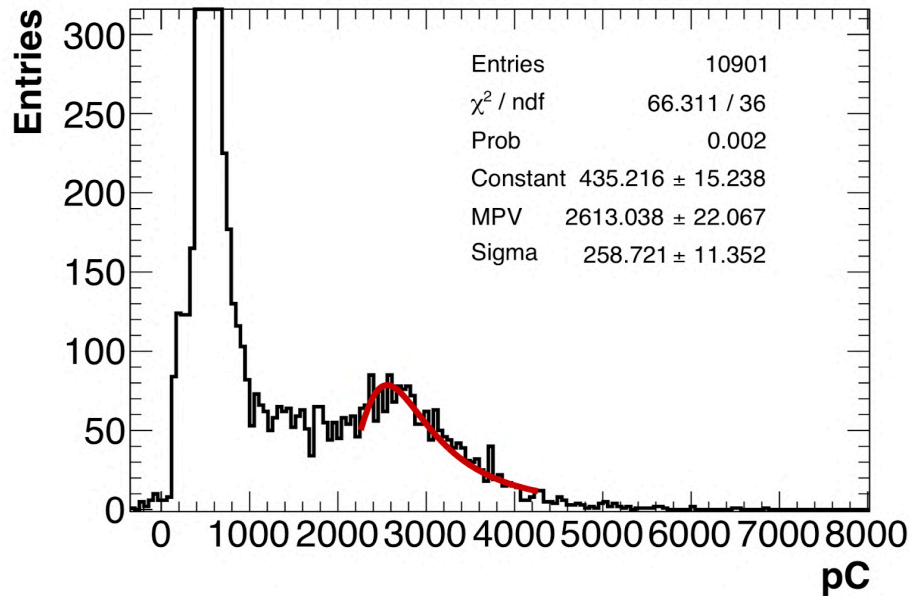

$$N_{p.e.} = \frac{2600 pC}{40 pC \cdot dE/dx} = 65 p.e. / (dE/dx)$$

- From Monte Carlo we extrapolated the MPV corresponding to an energy loss of $dE/dx = 11 \text{ MeV}$, from which a **light yield of ~6 p.e. / MeV** is derived.

Module-0

- In order to validate the design choices relative to the opto-electronic architecture of the calorimeter, a small scale prototype with 2 crystals and 4 amplification channels was developed according to the same front-end design of the Crilin prototype (see later).
- This first prototype was produced so as to characterize in detail the response of crystals and photosensors, with a focus on the time resolution evaluation with MIPs. Indeed, easing the first crystal as a trigger for cosmic rays, the charge and time resolution of the second can be evaluated against MIPs.
- For the latter, coupling with optical grease or silicone resin will be evaluated against the preferred option of direct coupling via an air gap and without the use of any optical coupling medium.
- Also the optical cross talk between the two crystals will be evaluated, by relying again on cosmic rays.
- A NIM module has been adapted to provide the regulated bias supply voltages and perform the conversion of the differential pulses to a single ended, 50 Ω adapted voltage signal. **The NIM module also embeds an additional gain 10 stage.**

Module-0 - Electronics -

Integrated FEE SiPMs amplification stage (gain x2)

- 2 series of 2 SiPMs per channel
- Two separate amplification stages per channel
- Integrated TIA (8 kOhm gain) and differential driver
- Integrated HV distribution stage (offline gain equalisation)
- ThermaBridge and cooling copper pads

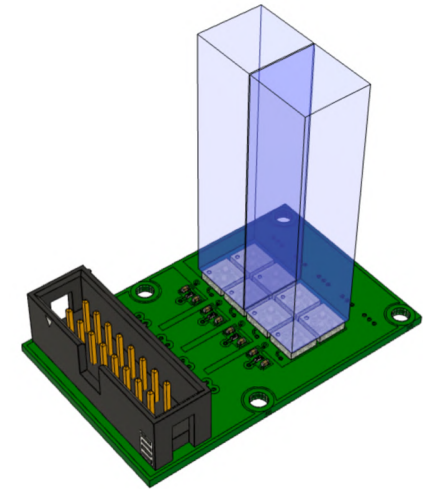

Bottom view

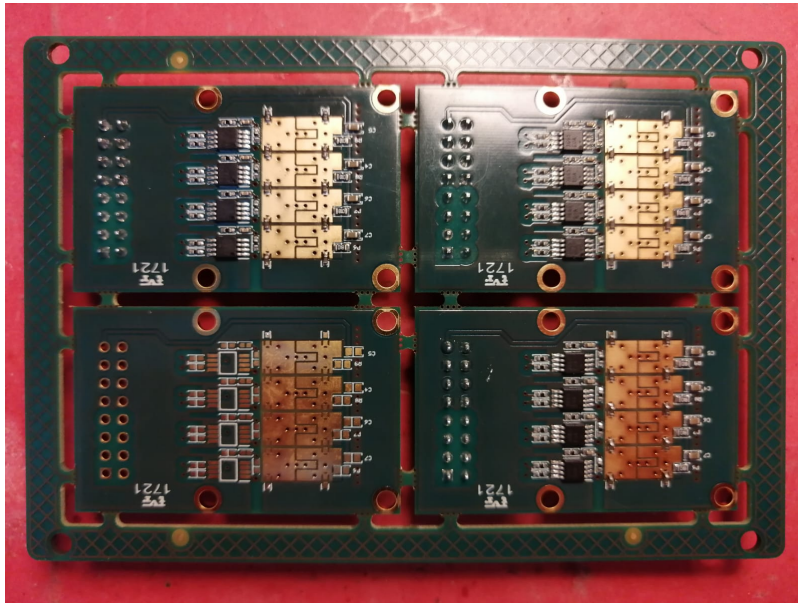

Top view

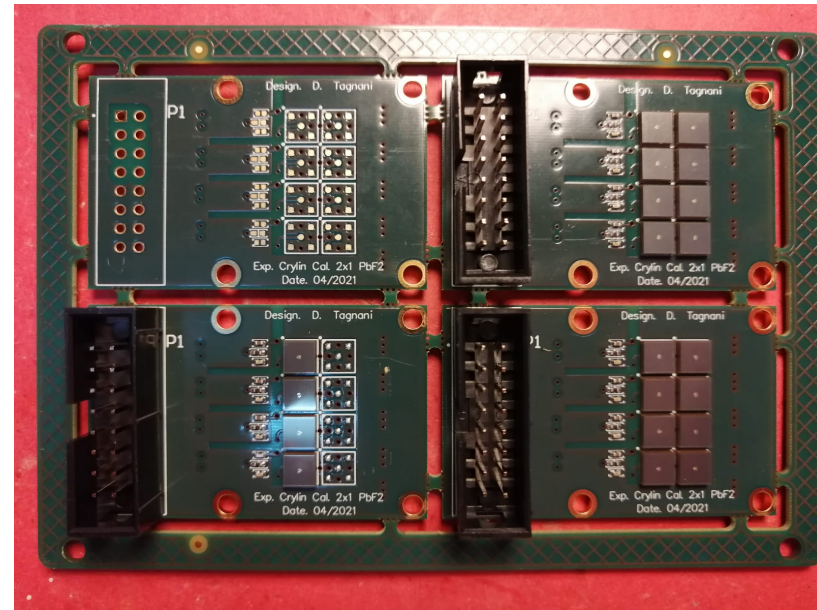

Module-0 - Electronics 2 -

QCaIT 4channels NIM module (2010) settled and adapted for Crilin FEE

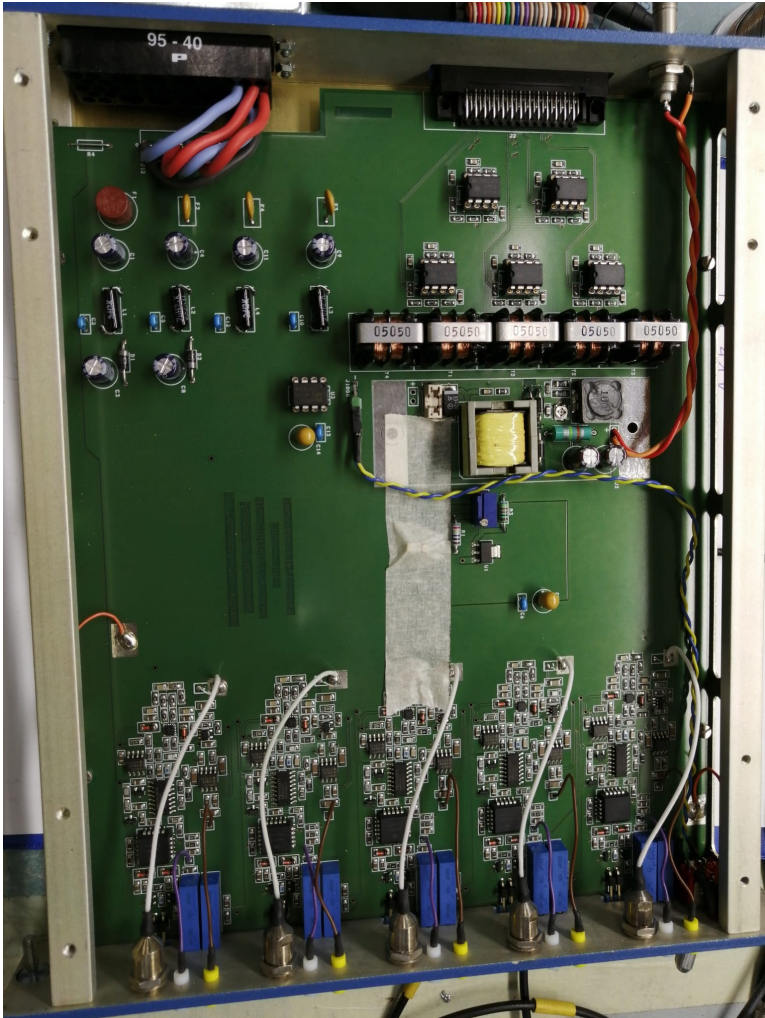

One channel with LED

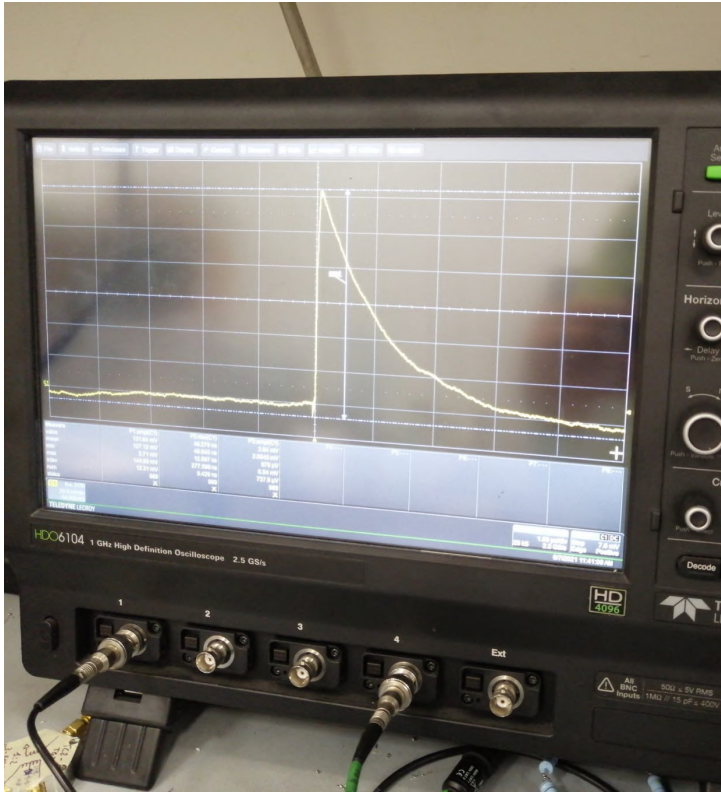

Module-0 - Mechanics -

- Two 10x10x40 mm³ PbF₂ crystals w/ Mylar wrapping → 4 readout channels
- Additive manufacturing fabrication (FMD/ASA or PolyJet/VeroBlack)
- Integrated cooling systems in each module
- Dry, cold gas fluxing
- Integrated crystal locking system

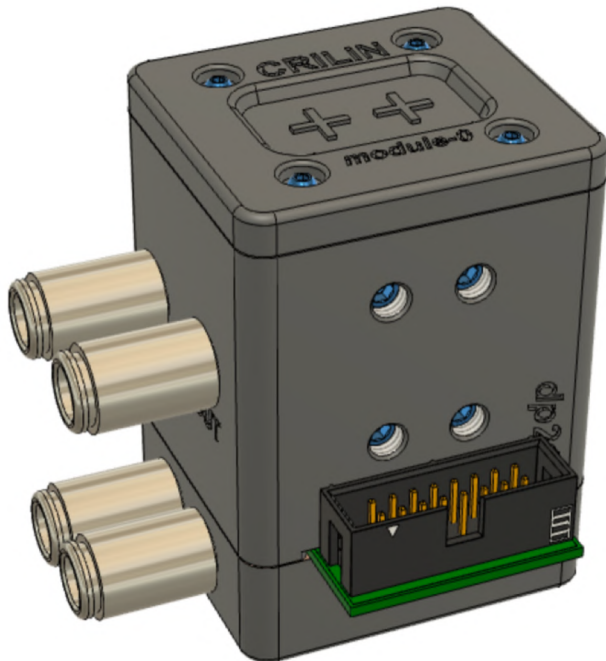

**61x40x44 mm³
overall size**

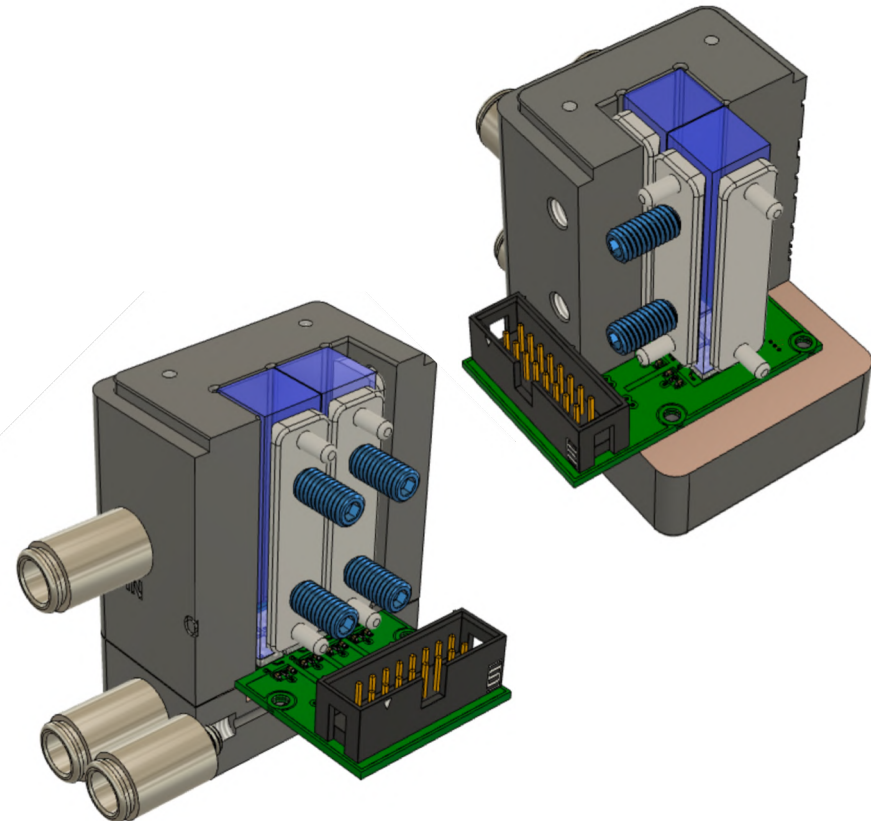

Conclusions and Next Steps

- Crilin calorimeter wants to overcome the two standard calorimeter categories, **homogeneous** and **sampling**, trying to be a good compromise between the two in order to optimize the requirements of a future Muon Collider and minimize the negative sides of one or the other choice.
- Crilin is a 4D calorimeter (3D+time), each cell must have an excellent timing resolution to reconstruct the event.
- Before the construction of the prototype we have analyzed and tested the single parts:
 - 1) **Irradiation studies of Crystals and SiPMs are over** → Dedicated paper will be submitted before the end of June 2021.
 - 2) **Module-0 will be ready before the end of June 2021** → Test Beam at BTF with 500 MeV electrons in July 2021 and at Cern on 18-25 of August in collaboration with Klever team.

TDR published as LNF Preprint

<http://www.lnf.infn.it/sis/preprint/detail-new.php?id=5912>

Spese 2021

18 Cristalli e 100 SiPMs comprati a fine 2020 su avanzi dot.gr1 (LNF e Torino)

- **Assegnazione 2021 → 10keuro**
 - **1.7keuro**: schede elettronica per modulo-0
 - **0.5keuro**: 5 cristalli per modulo-0
 - **0.5keuro**: componenti elettronici da RS
 - **4.5keuro**: chiller di dimensioni portabile

Totale speso ad oggi 7.2keuro

Residuo 2021

- 1keuro: Concludere acquisti per il cooling (sistema di scambiatore a piastre e sistema di controllo)
- 0.2 keuro: stampa 3D modulo-0
- 0.6 keuro: spese varie legate al test beam (metabolismo)
-

End 2021 ÷ All 2022

Crilin Prototype

A Crilin prototype, composed of 2 layers of 9 crystals each and operating at 0 °C, could be built starting from end 2021.

Crilin Prototype

- The prototype consists of two submodules, each composed of a 3-by-3 crystals matrix.
- The submodules are arranged in a series and assembled together by screws, resulting in a compact and small calorimeter

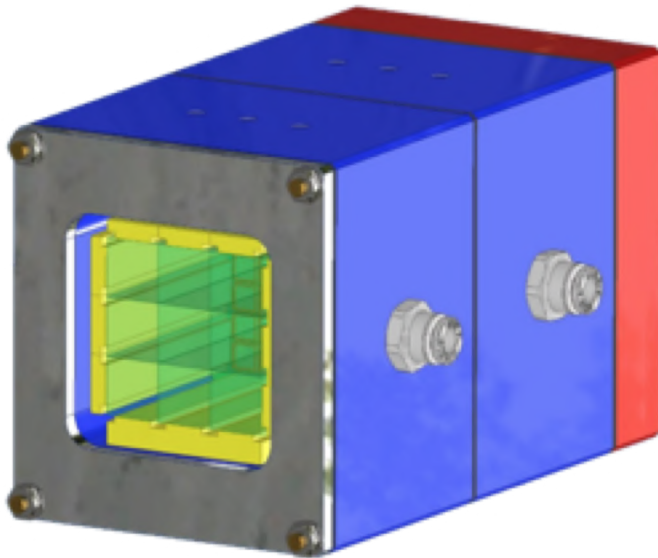
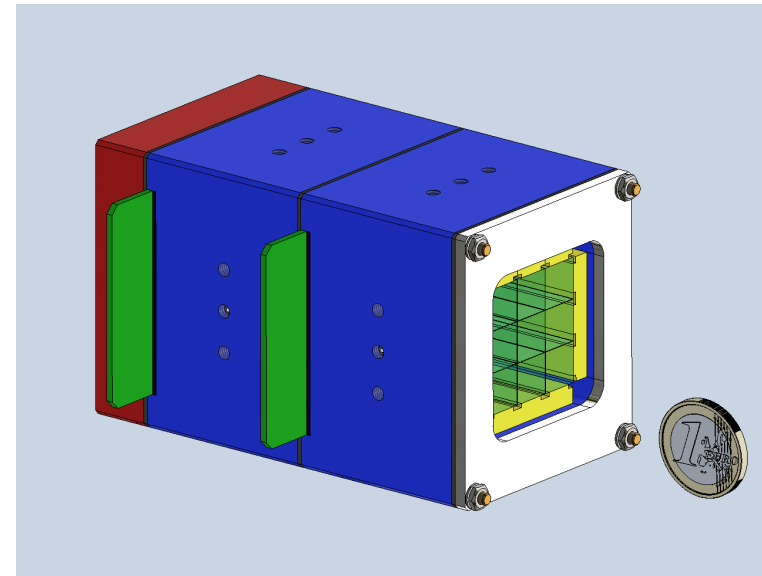

- Our design is capable of removing the heat load due to the increased photosensor currents after exposure to the expected 10^{12} n1MeV/cm² fluence, along with the power dissipated by the amplification circuitry. **The total heat load was estimated as 350 mW per channel.**
- The Crilin cooling system, which is based on conduction and forced convection of nitrogen, will provide the optimum operating temperature for the electronics and SiPMs at around 0 °C.

Crilin Prototype - Electronics

- The PCB layout was conceived so that, for each crystal, the amplification and bias distribution circuitry - mounted on the bottom side - could be contained in the footprint of the 4 photodetectors mounted on the top side.
- The chosen PCB solder mask for the final prototype is in black colour, an element which can be beneficial in preventing cross talk from happening at the SiPM-crystal interfaces.

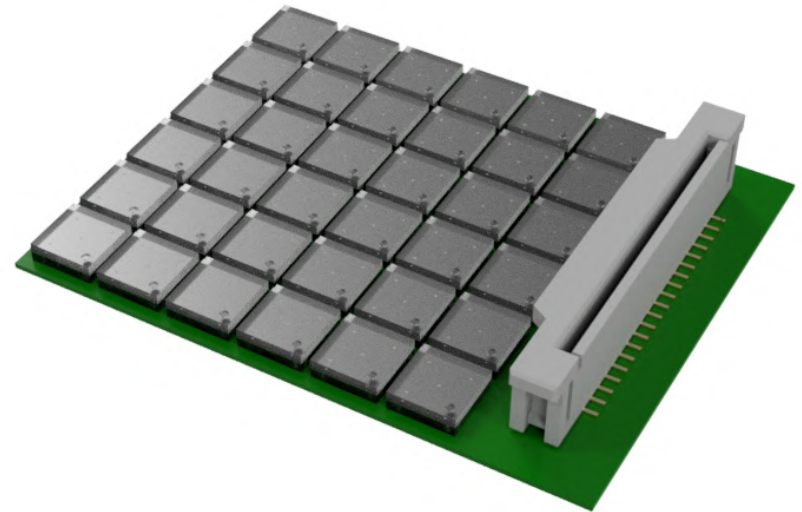

- The differential outputs are back terminated with 50Ω per side. The nominal transimpedance gain is $8 \text{ k}\Omega$. In our case this corresponds to an overall charge **gain of about 2.**
- A control module will be developed in standard NIM format to provide the regulated bias supply voltages and perform the conversion of the differential pulses to a single ended, 50Ω adapted voltage signal. **The NIM module also embeds an additional gain 10 stage.**

Crilin Prototype - Richieste

➤ Richieste 2022 → 33keuro

- **2keuro** meccanica:
Costruzione prototipo + coinventazione + possibile uso della fibra di carbonio (guardando a Crilin)
- **15keuro** elettronica:
2+1 board da 18 canali (gain x2) + 4 cassette NIM ricevitori da 10 canali ognuno (gain x10 opzionale) per trasformare da differenziale a single endend e gestire l'HV + 1 crate di gestione (ad alimentazione lineare)
- **1keuro** di metabolismo (spedizioni, cavi e accessori)
- **15keuro** acquisizione fast per i 36 canali del prototipo.

--- richieste per 2021:

3keuro per elettronica (implementazione cassetto di prova NIM 10 canali)

3keuro per studio acquisizione di acquisizione fast (fast TDC e carica tramite time over threshold)

SPARES



CRILIN
the semi-homogeneous crystal calorimeter

Example of application: Muon Collider Ecal

- The present Ecal in the simulation framework is based on 1.9 mm W + silicon pad layers:
 - 40 layers
 - 5x5 mm² cells
 - 22 X₀ + 1 λ_I
 - barrel (with dimension 4 m x 3 m) + 2 endcap
 - Very expensive, huge amount of channels
 - Low time resolution
- However, this high segmentation allows setting the requirement for the calorimeter
 - Lets see an example

Muon ID with the calorimeter -1-

- The identification of high p_T muons could be difficult with just the Muon Detector \rightarrow the calorimeter can be used to improve it.
- For such purpose, the longitudinal segmentation is important to reconstruct muon tracks in the calorimeter.

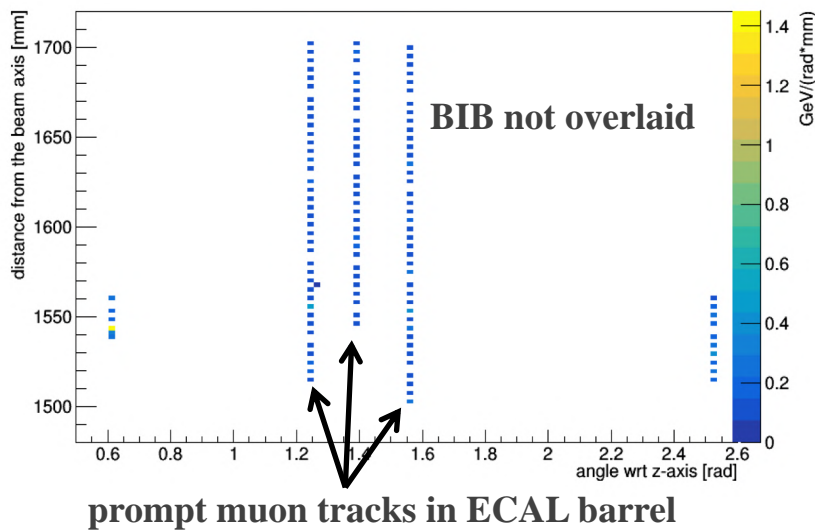

Energy released in ECAL barrel by uniformly distributed prompt muons in the (θ, ϕ) space

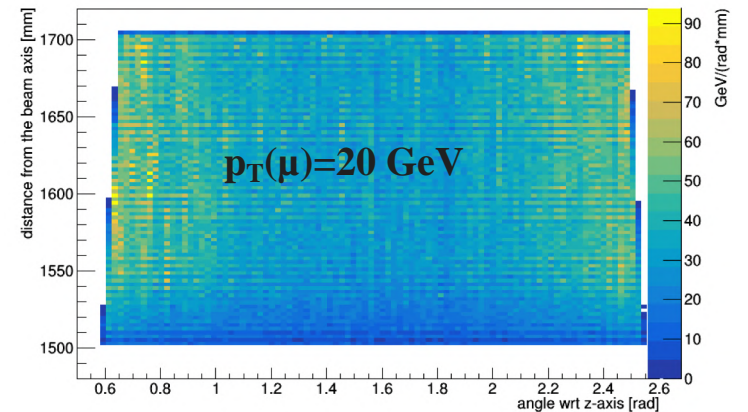
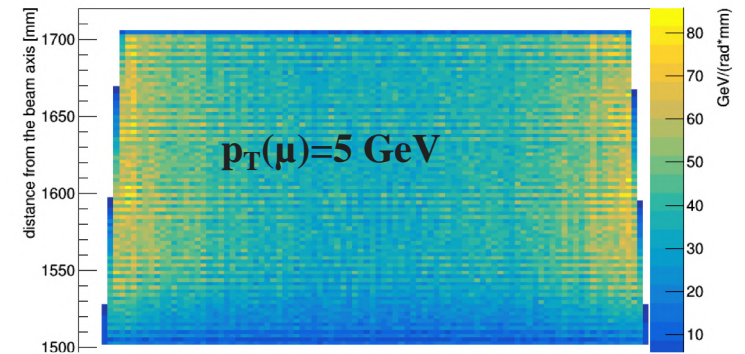

A Crystal Calorimeter with Longitudinal information

- Calorimeter Layout: **the calorimeter can be segmented longitudinally** as a function of the energy of the particles and the background level.

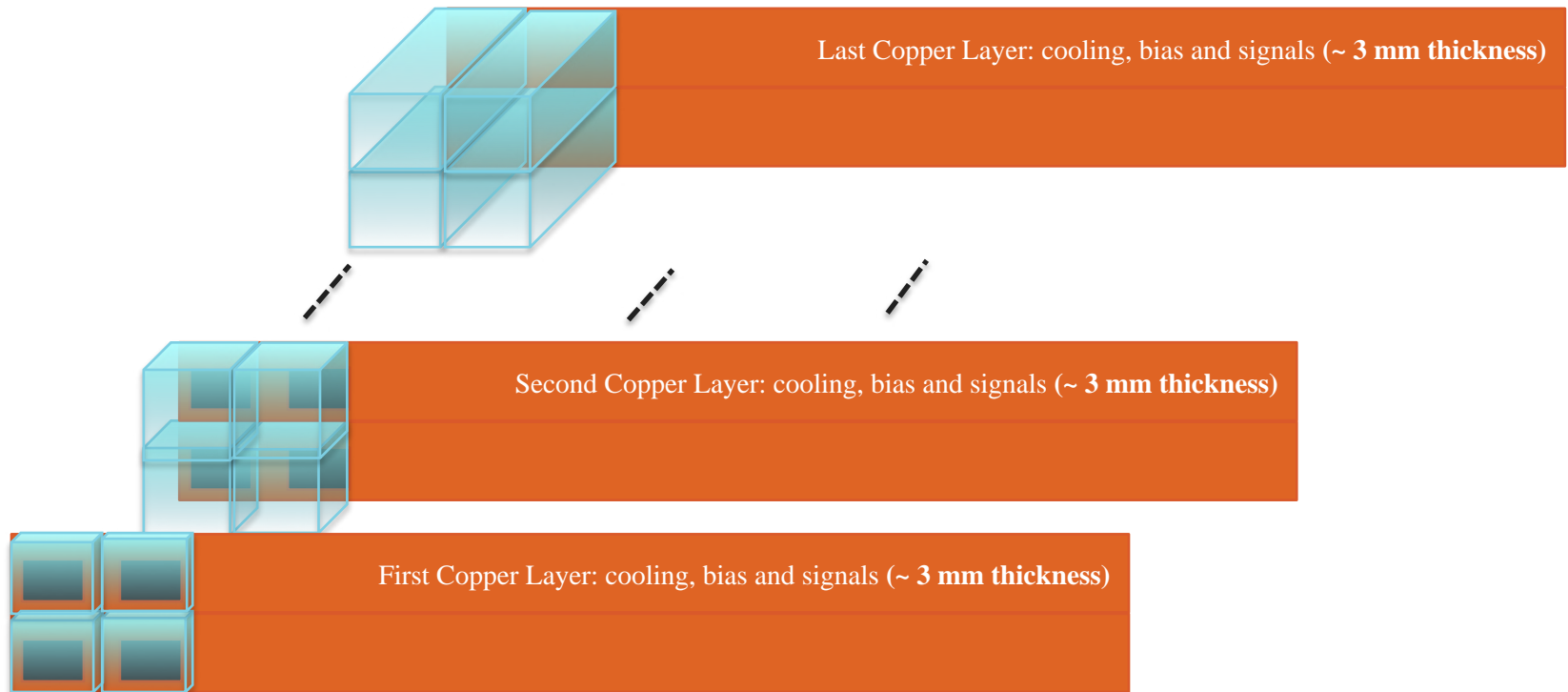

Timing resolution

- As far as timing resolution is concerned, in this configuration the stochastic term linked to PbF2 would be practically zero, while the dominant contribution would be linked to the rise time of the signal.
- The rise-time of SiPM pulses is in the order of the nanosecond, while the rise-time of the FEE depends on the choice of the amplifier.
- Assuming a total rise-time of approximately 3-5 ns for the SiPM and FEE, the achievable time resolution would be of the order of 3-5 ns/sqrt(Np.e).

This corresponds to 300 ps in the case of high impulse muons and up to 50 ps in the case of pions and jets. → will be measured with the module-0 (see later)

Optical Bleaching

- After 16 hours of optical bleaching, recovery of only a few percent on the transmittance spectrum was observed.
- This could indicate that the effect of the natural and induced annealing are quantitatively at the same amount. Bleaching seems to only speed up the natural annealing of the crystals.

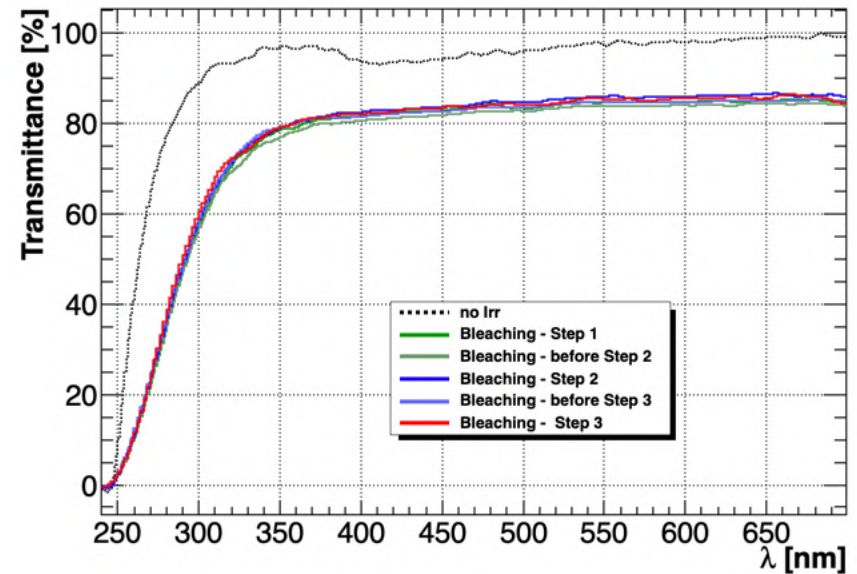
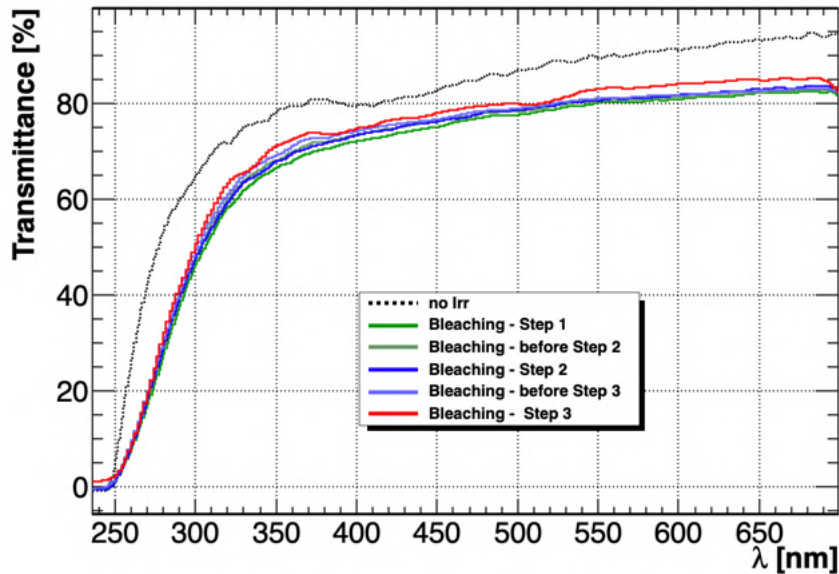

- Step 1: six hours of bleaching
- Step 2: ten hours of bleaching
- Step 3: sixteen hours of bleaching

Crilin Prototype

- The prototype consists of two submodules, each composed of a 3-by-3 crystals matrix.
- The submodules are arranged in a series and assembled together by screws, resulting in a compact and small calorimeter

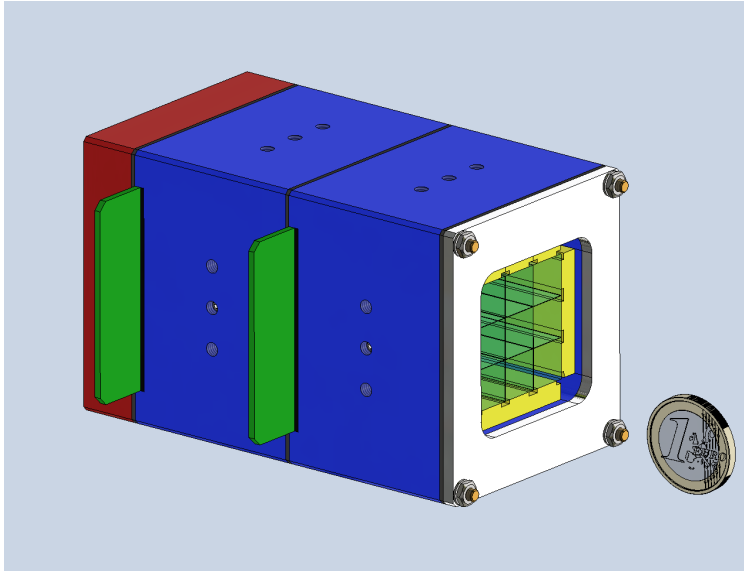

1. The cases, which house the crystal matrix and embed the front-end electronic boards. They are manufactured in aluminium alloy (EN AW 6082) and ABS to ensure the thermal insulation.

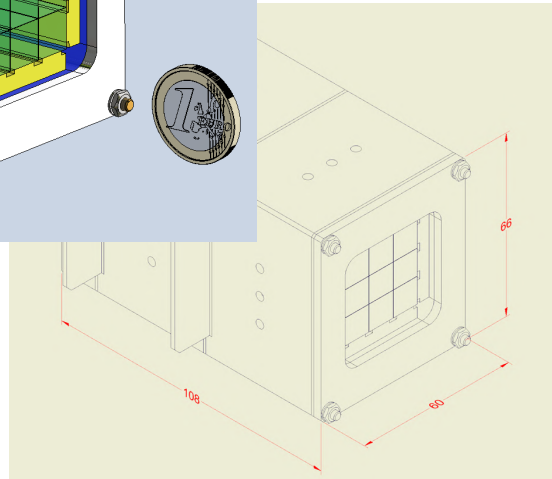

Crilin Prototype - 2 -

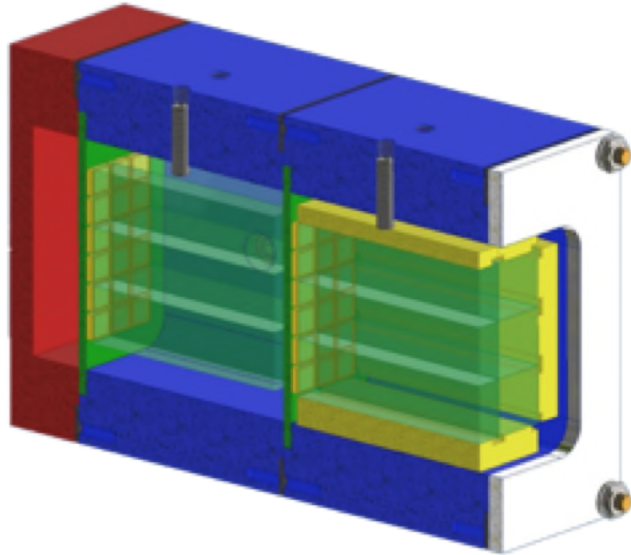

2. The locking plates, which ensure the positioning and the blocking of the crystals inside the case, are manufactured in ABS.
→ *This solution eases the assembling, positioning and locking of the crystals matrix.*

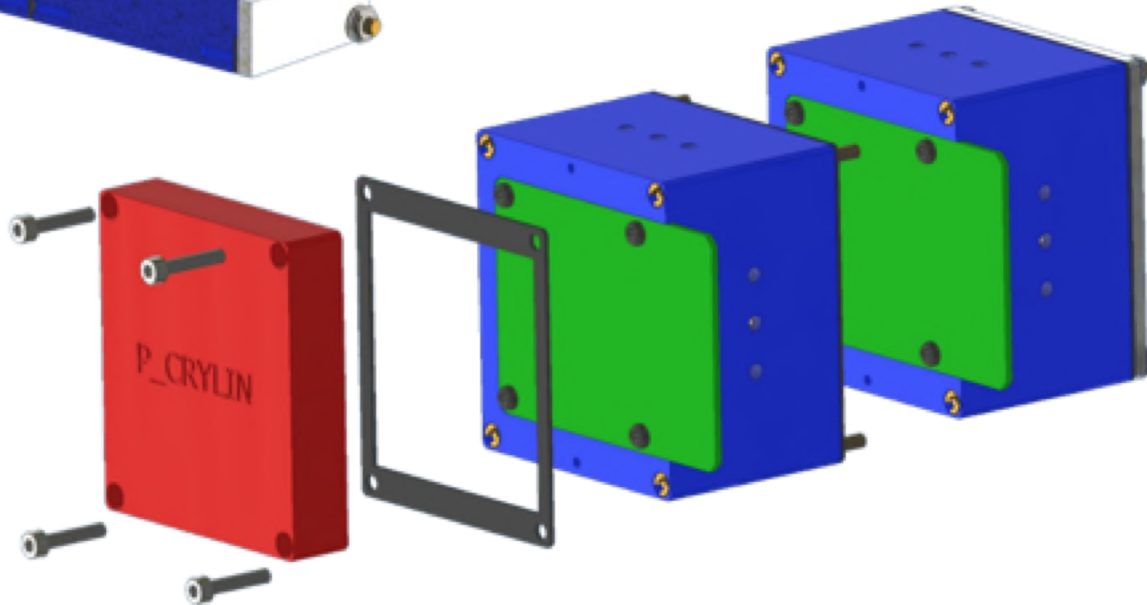

Crilin Prototype - 3 -

- The on-detector electronics and SiPMs must be cooled during operation, so as to improve and stabilise the performance of SiPMs against irradiation
- Our design is capable of removing the heat load due to the increased photosensor currents after exposure to the expected 10^{12} n1MeV/cm² fluence, along with the power dissipated by the amplification circuitry. **The total heat load was estimated as 350 mW per channel.**
- The Crilin cooling system, which is based on conduction and forced convection of nitrogen, will provide the optimum operating temperature for the electronics and SiPMs at around 0 °C.

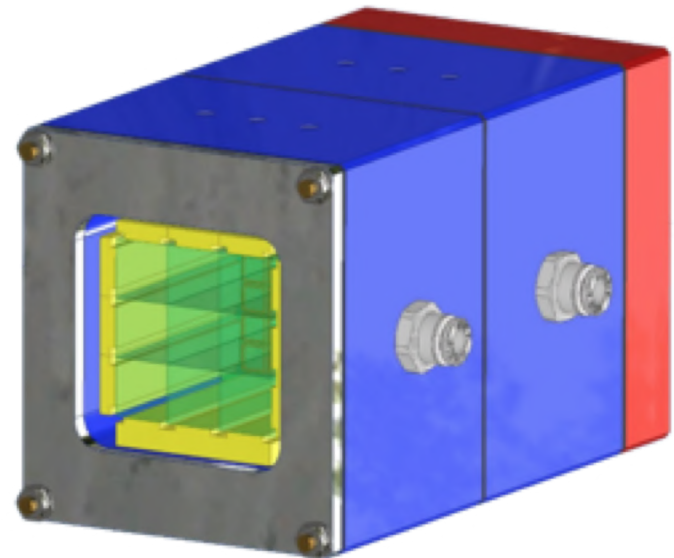

Crilin Prototype - Electronics

- Each crystal is in turn individually readout by a square matrix of 4 SiPMs (Hamamatsu S14160-4050HS) in surface-mount technology, connected in two series of 2 photosensor each.
- All SiPMs contained in each submodule are biased using a common positive supply generated externally and distributed to all channels after filtering.
- This architecture was implemented due the small spread in the breakdown voltages of the SiPMs contained in each matrix, which are carefully matched.
→ The overall RMS spread in breakdown voltages for all 72 SiPMs installed in the prototype is 6.3 mV.

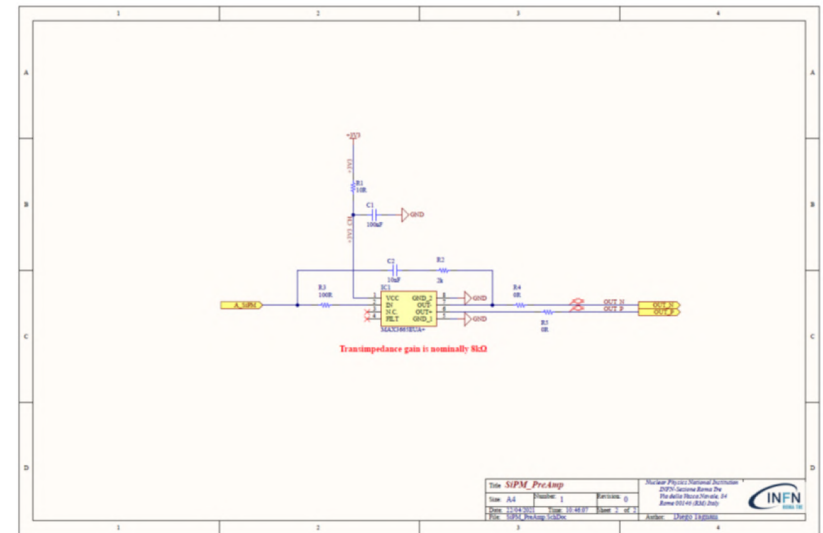
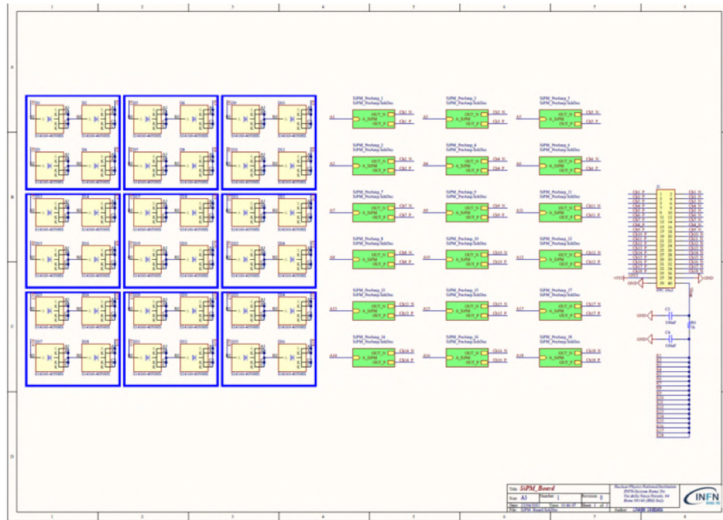

Crilin Prototype - Electronics

- The PCB layout was conceived so that, for each crystal, the amplification and bias distribution circuitry - mounted on the bottom side - could be contained in the footprint of the 4 photodetectors mounted on the top side.
- The chosen PCB solder mask for the final prototype is in black colour, an element which can be beneficial in preventing cross talk from happening at the SiPM-crystal interfaces.

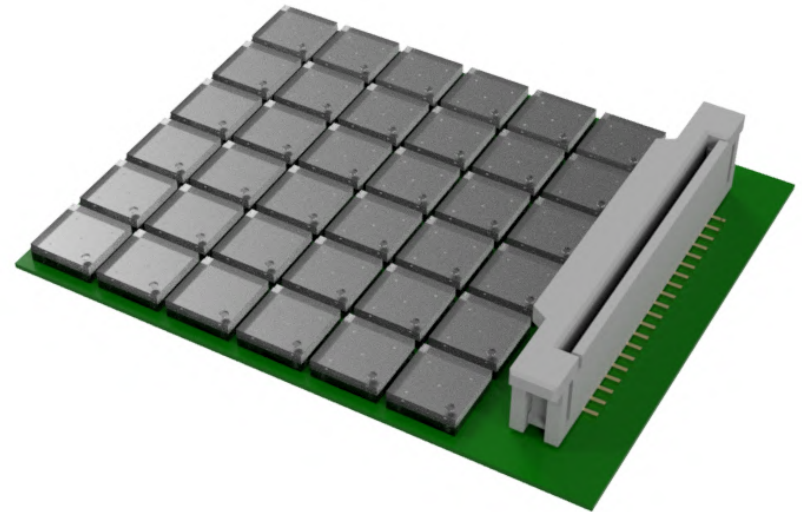

- The differential outputs are back terminated with 50Ω per side. The nominal transimpedance gain is $8 \text{ k}\Omega$. In our case this corresponds to an overall charge **gain of about 2.**
- A control module was developed in standard NIM format to provide the regulated bias supply voltages and perform the conversion of the differential pulses to a single ended, 50Ω adapted voltage signal. **The NIM module also embeds an additional gain 10 stage.**