

Alla ricerca di nuova fisica con il metro cubo più freddo dell'Universo

Alessio Caminata
INFN Genova

Le particelle elementari

Le particelle elementari

three generations of matter (fermions)						
	I	II	III			
mass	$\approx 2.4 \text{ MeV}/c^2$	$\approx 1.275 \text{ GeV}/c^2$	$\approx 172.44 \text{ GeV}/c^2$	0	$\approx 125.09 \text{ GeV}/c^2$	
charge	$2/3$	$2/3$	$2/3$	0	0	
spin	$1/2$	$1/2$	$1/2$	1	0	
	u up	c charm	t top	g gluon	H Higgs	
	d down	s strange	b bottom	γ photon		
	e electron	μ muon	τ tau	Z Z boson		
	ν_e electron neutrino	ν_μ muon neutrino	ν_τ tau neutrino	W W boson		

→ Protone e neutrone



↓ Processi nucleari

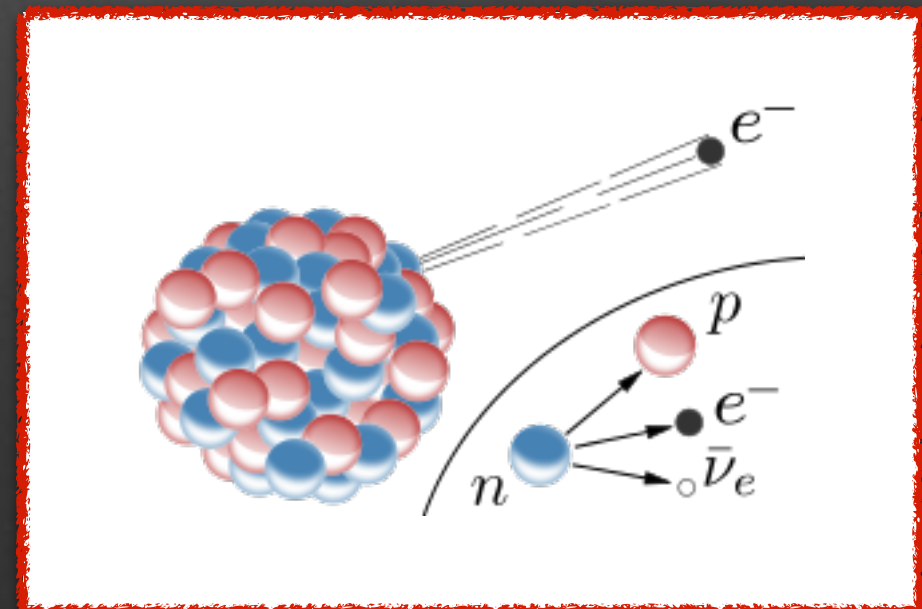

Il mistero dell'asimmetria materia-antimateria



Materia - Antimateria - Emma Ciriaci
Art&Science passata edizione

Il mistero dell'asimmetria materia-antimateria

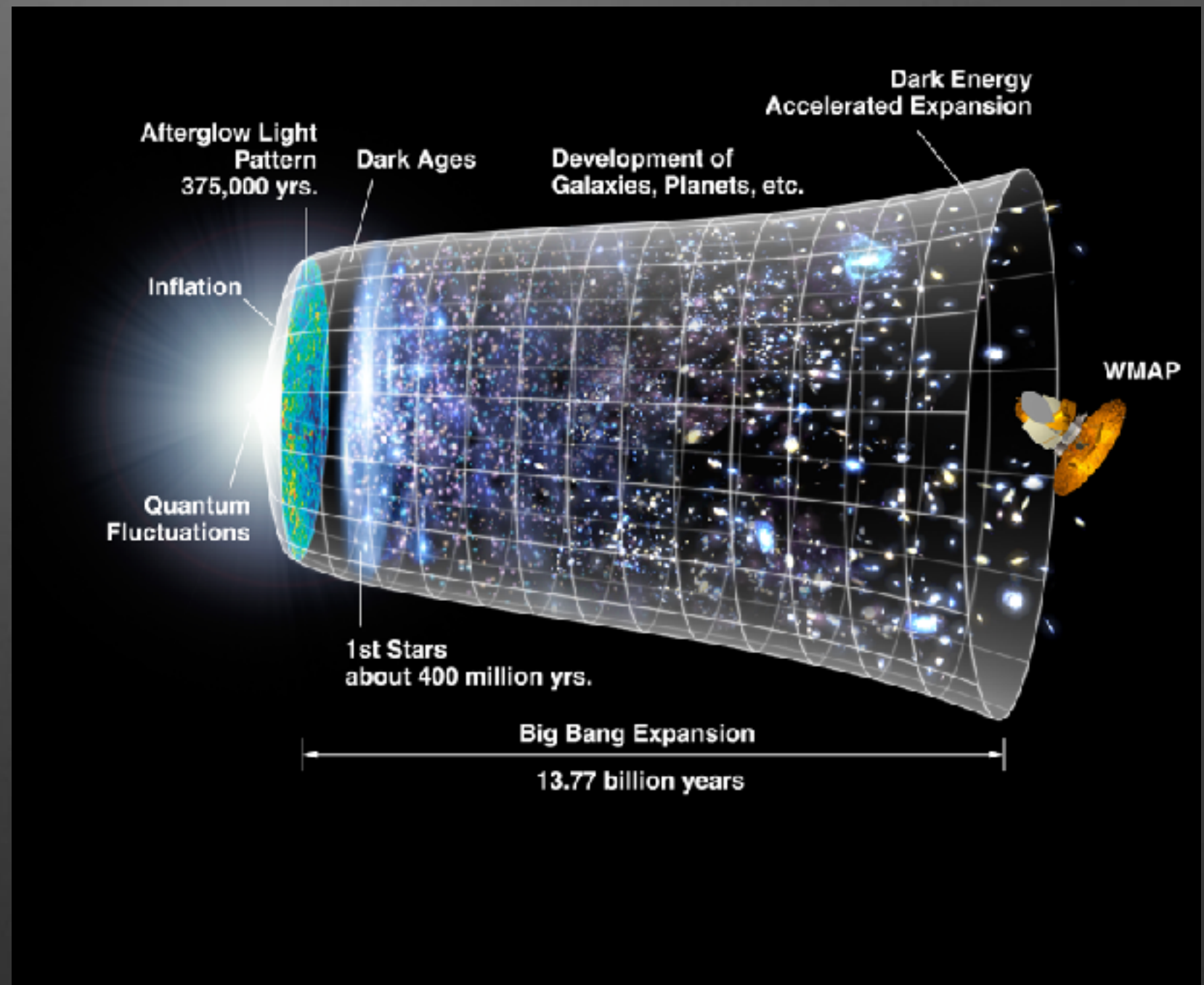
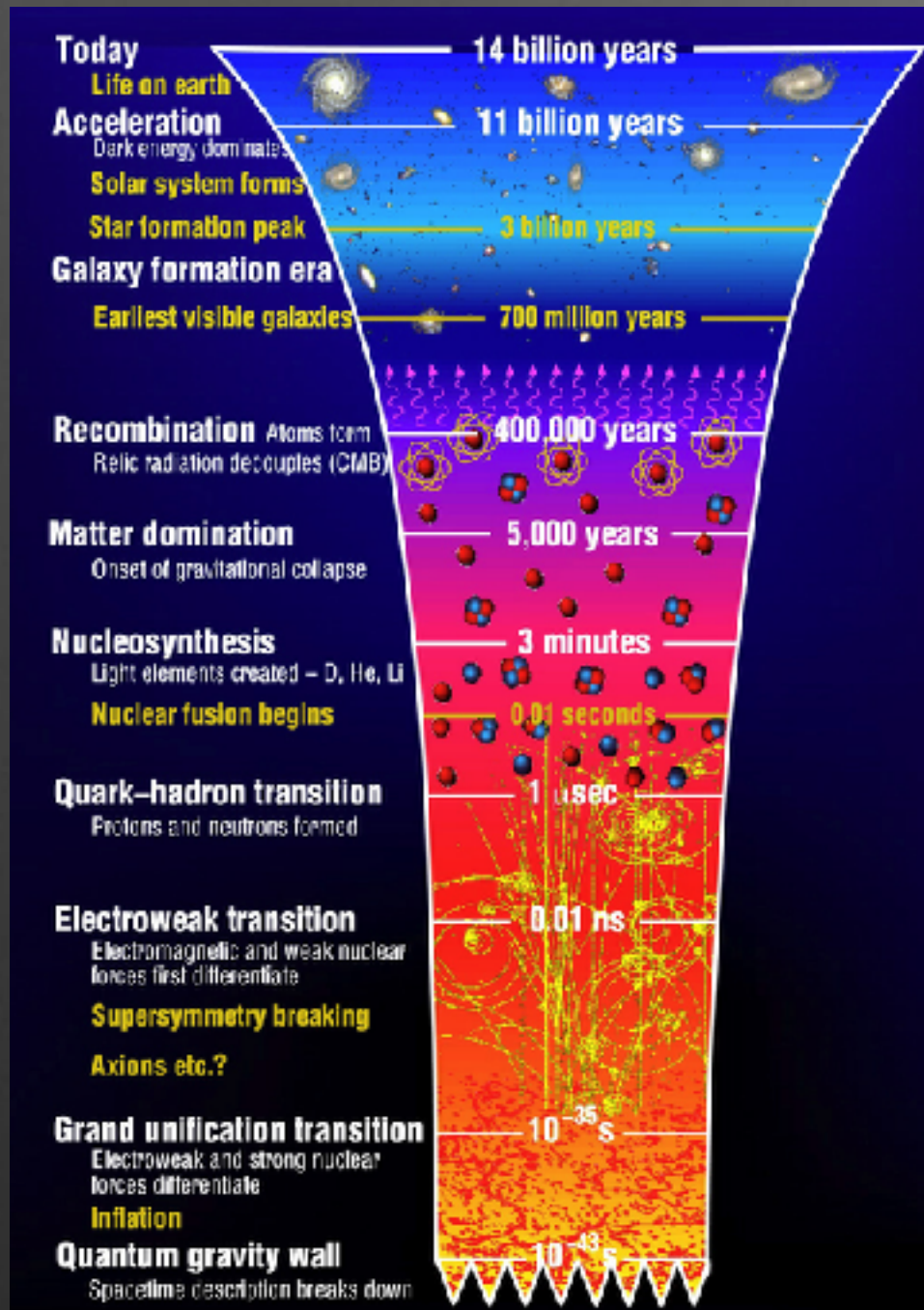

Le masse delle particelle elementari

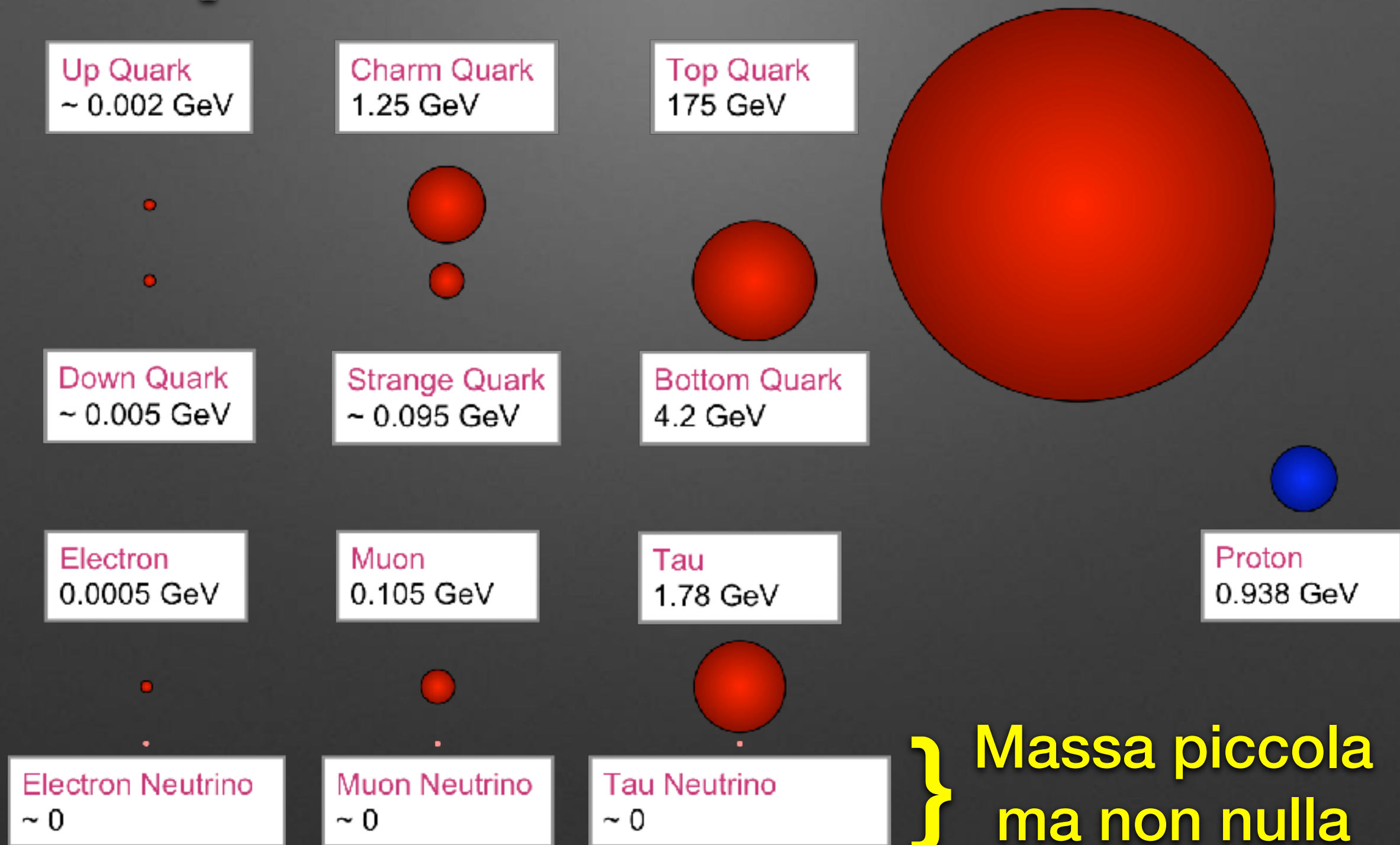

La massa dei neutrini

- Sappiamo che la massa di queste particelle deve essere diversa da zero grazie al fenomeno di oscillazione di sapore del neutrino

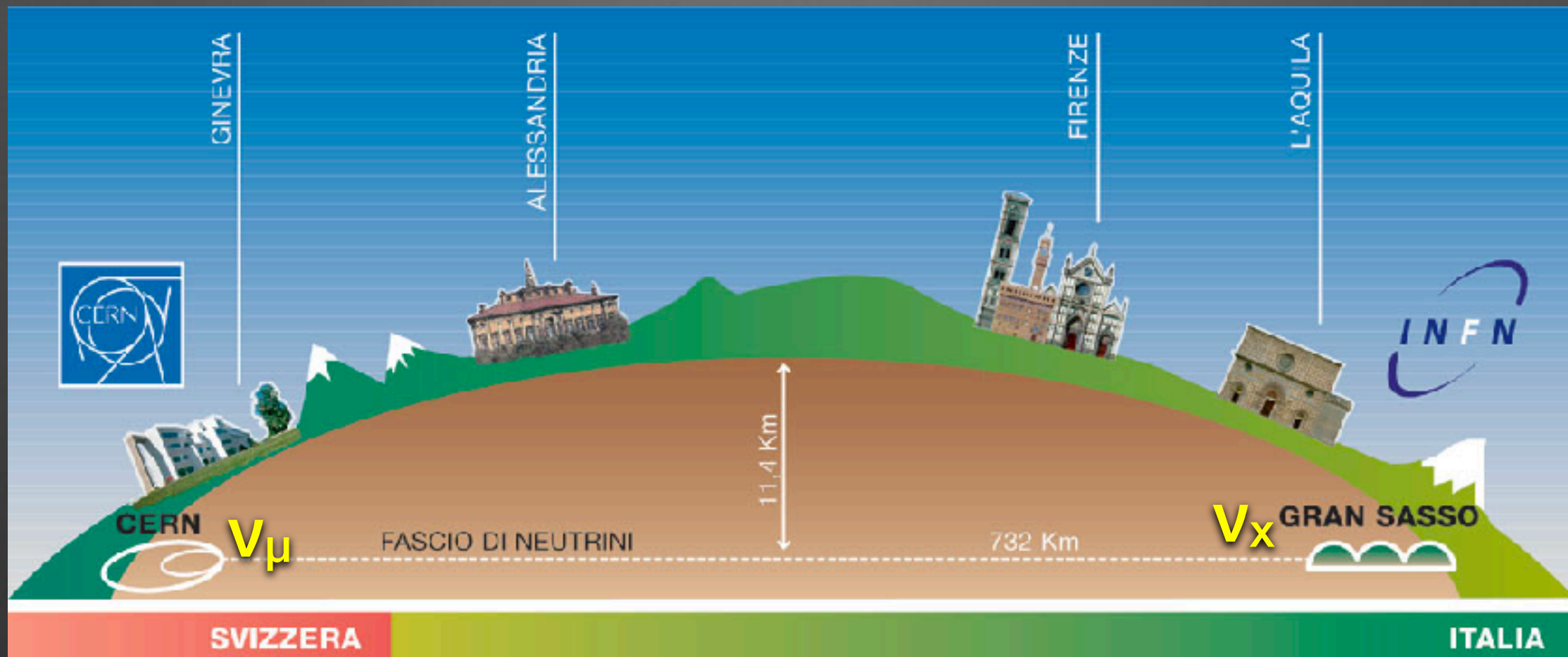

- Tuttavia è molto piccola e non ancora misurata sperimentalmente

I misteri dei neutrini

- Perché la massa dei neutrini è così piccola?
Come possiamo misurarla?
- I neutrini non hanno cariche: sono antiparticelle di loro stessi? (particella di Majorana)

I misteri dei neutrini

- Perché la massa dei neutrini è così piccola?
Come possiamo misurarla?
- I neutrini non hanno cariche: sono antiparticelle di loro stessi? (particella di Majorana)

Ricerca del doppio decadimento beta senza emissione di neutrini ($0\nu\beta\beta$)

Cosa è il decadimento β

- Decadimento noto da inizio '900
- Inquadramento teorico sviluppato da Fermi
- $n \rightarrow p + e^- + \bar{\nu}_e$

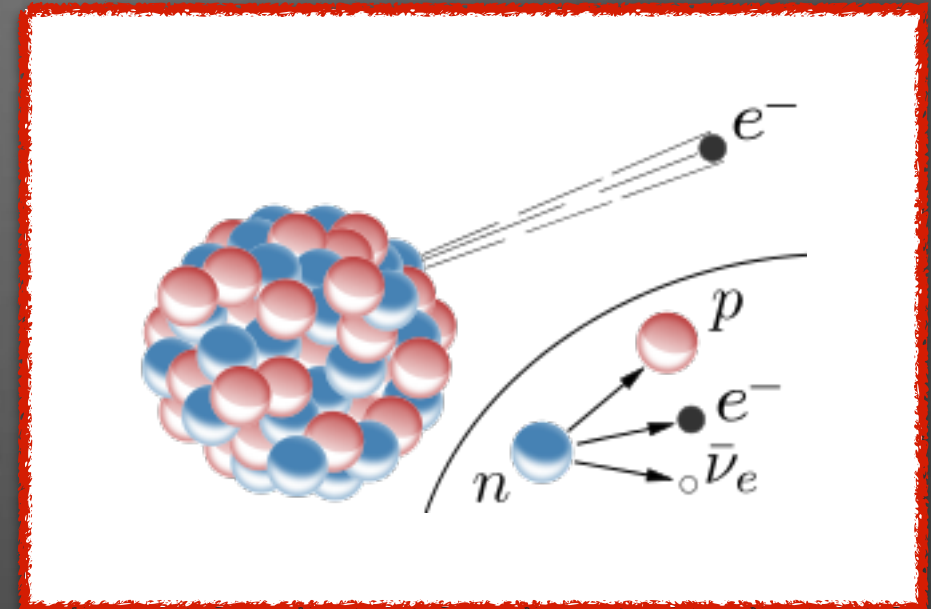

L'energia del decadimento si suddivide tra $e^- + \bar{\nu}_e$

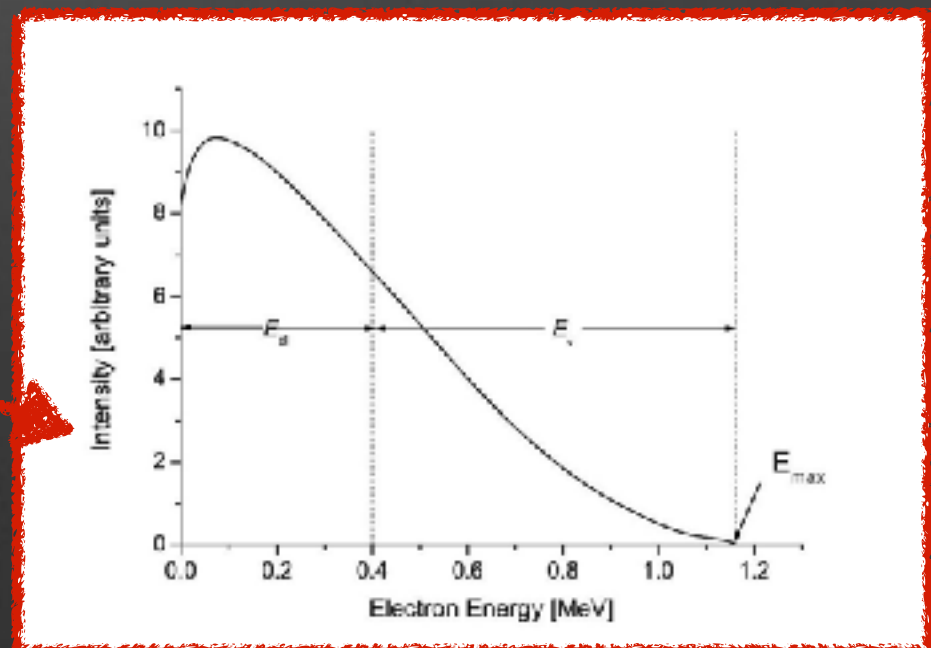

Doppio decadimento β

- Decadimento più raro del precedente
- Avviene quando il decadimento β non è ammesso per considerazioni energetiche
- $2n \rightarrow 2p + 2e^- (+ 2 \bar{\nu}_e)$

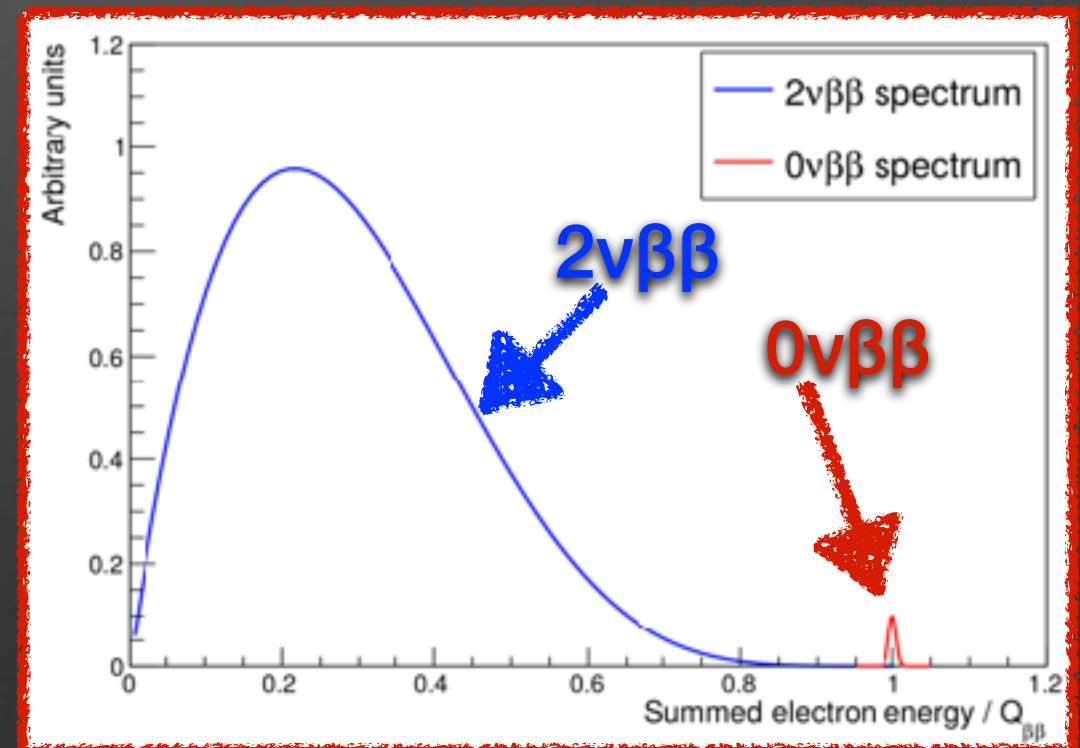
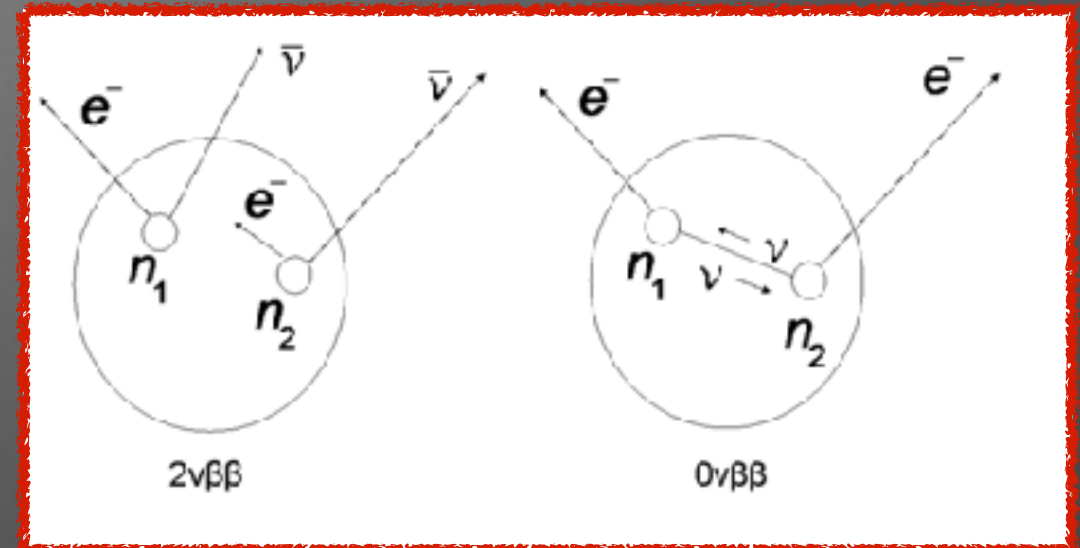

Doppio decadimento β

$2\nu\beta\beta$

- Osservato sperimentalmente in diversi nuclei ($T_{1/2}$ circa 10^{20} yr per ^{130}Te)
- È previsto dal modello standard delle particelle

$0\nu\beta\beta$

- Mai osservato sperimentalmente
- Può avvenire solo se il neutrino è antiparticella di se stesso
- La vita media del decadimento fornisce informazioni sulla **massa del neutrino**
- Il decadimento **viola la conservazione del numero leptonico**

Come indagare $0\nu\beta\beta$

- Decadimento molto raro:
 - Tanti nuclei sotto osservazione contemporaneamente -> arricchimento isotopico?
 - Lunga presa dati -> L'esperimento deve acquisire dati per anni
 - Pochi eventi di fondo nella regione dello $0\nu\beta\beta$ -> scelta accurata dei materiali e laboratori sotterranei

Alla ricerca del $0\nu\beta\beta$ con l'esperimento CUORE

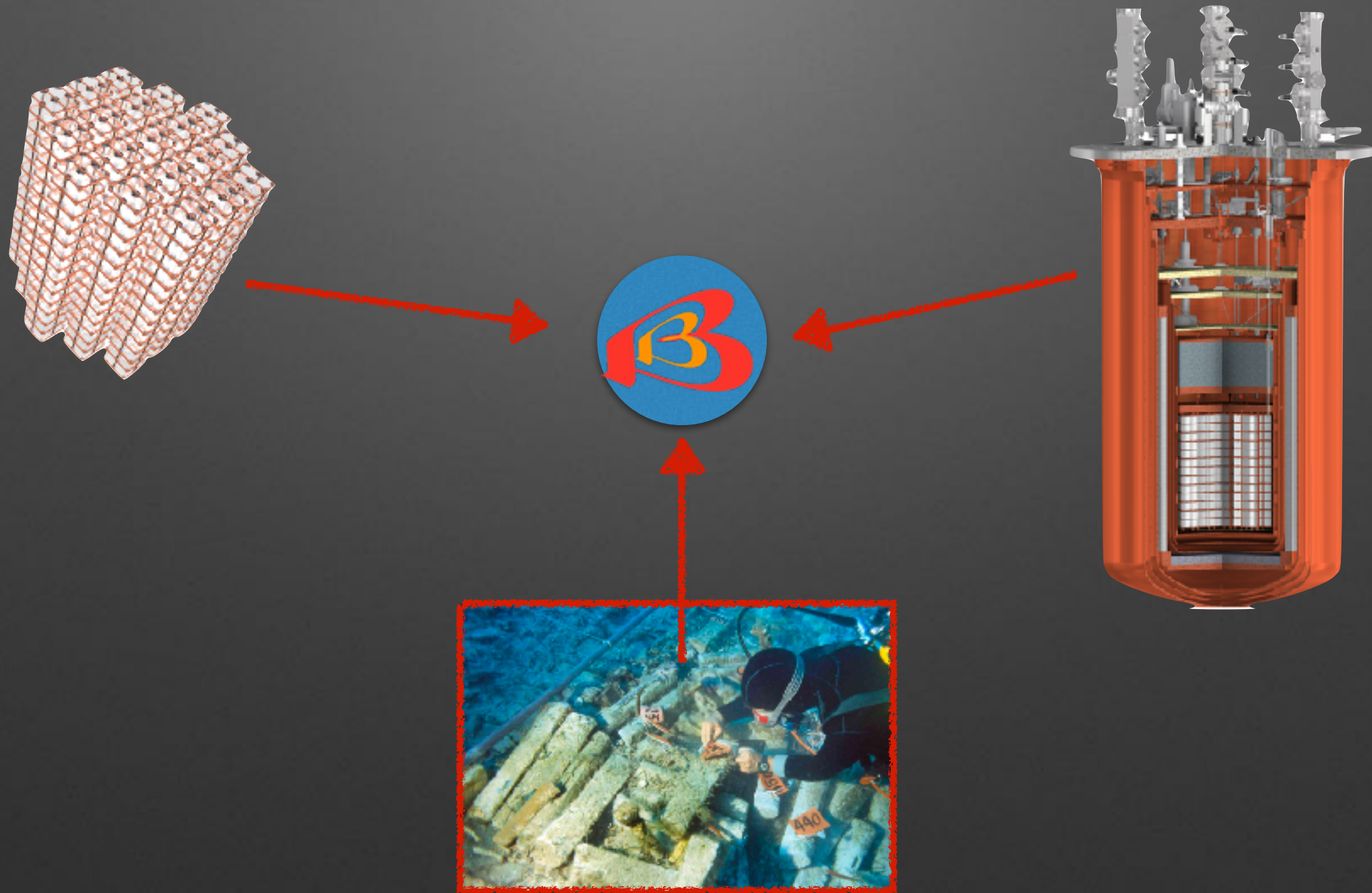



SAPIENZA
UNIVERSITÀ DI ROMA

Yale



UNIVERSITY OF
SOUTH CAROLINA





Foto pre-Covid

CUORE @ LNGS

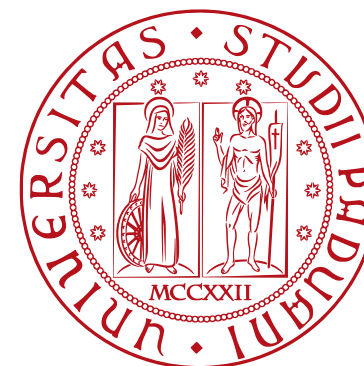
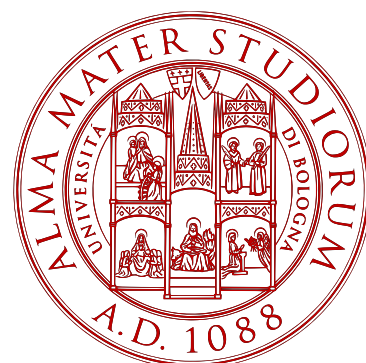
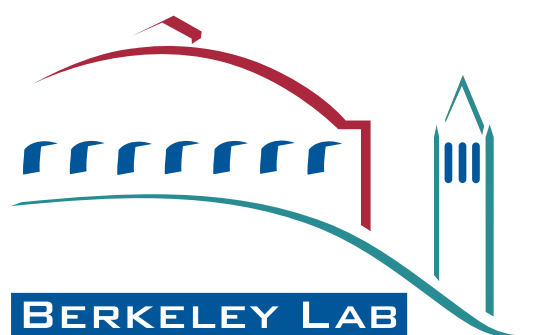

CUORE @ LNGS

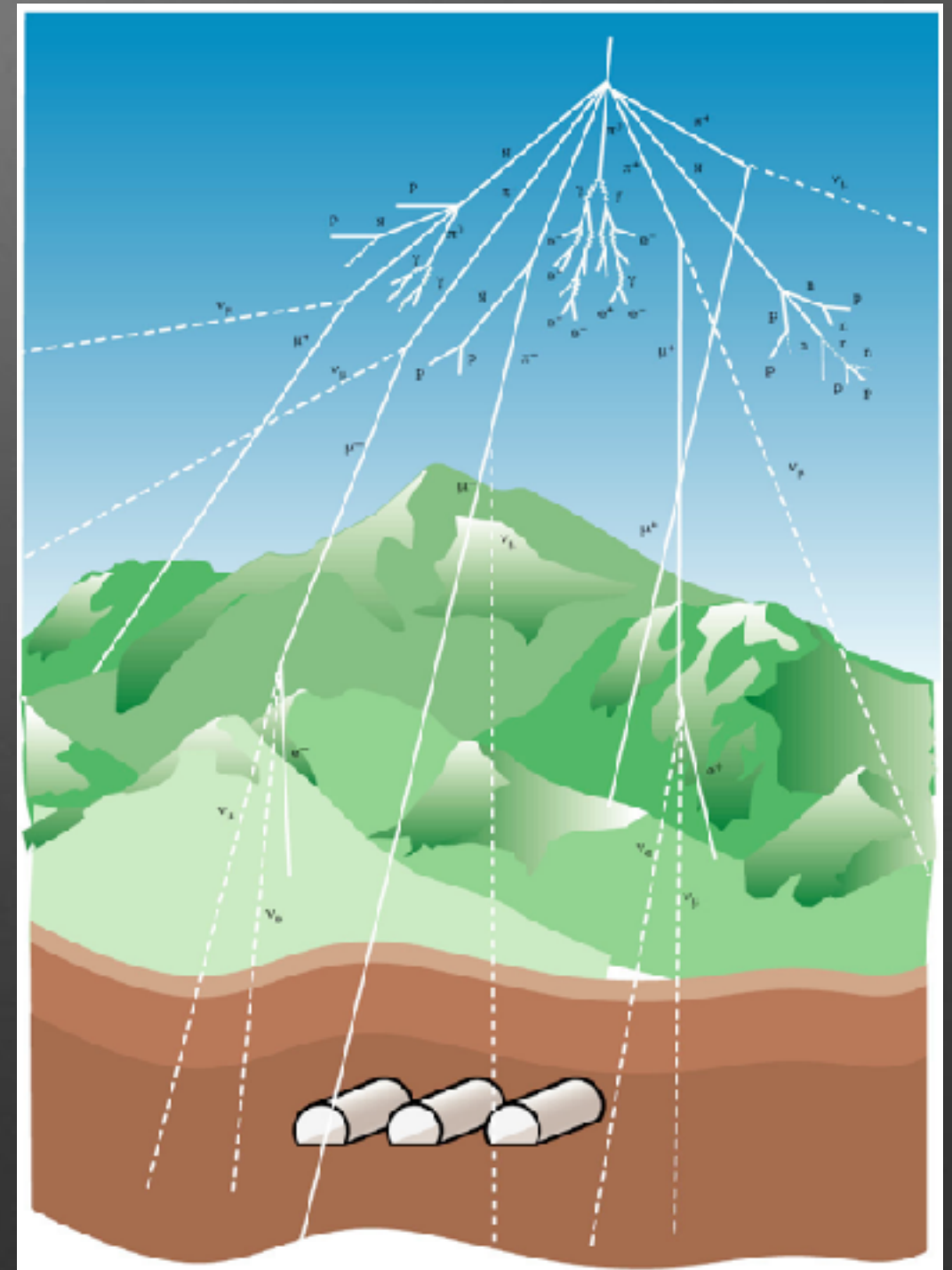
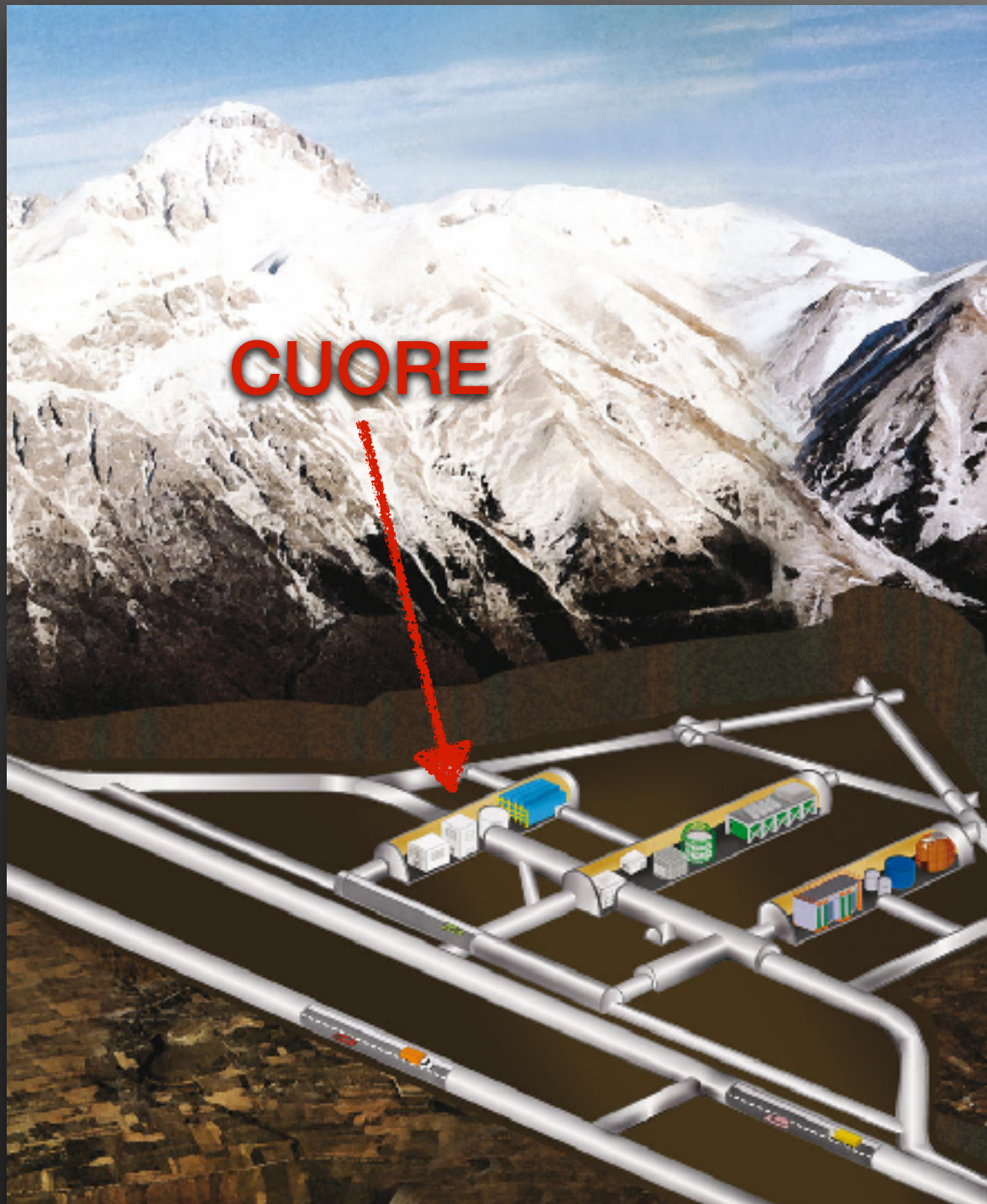

CUORE @ LNGS

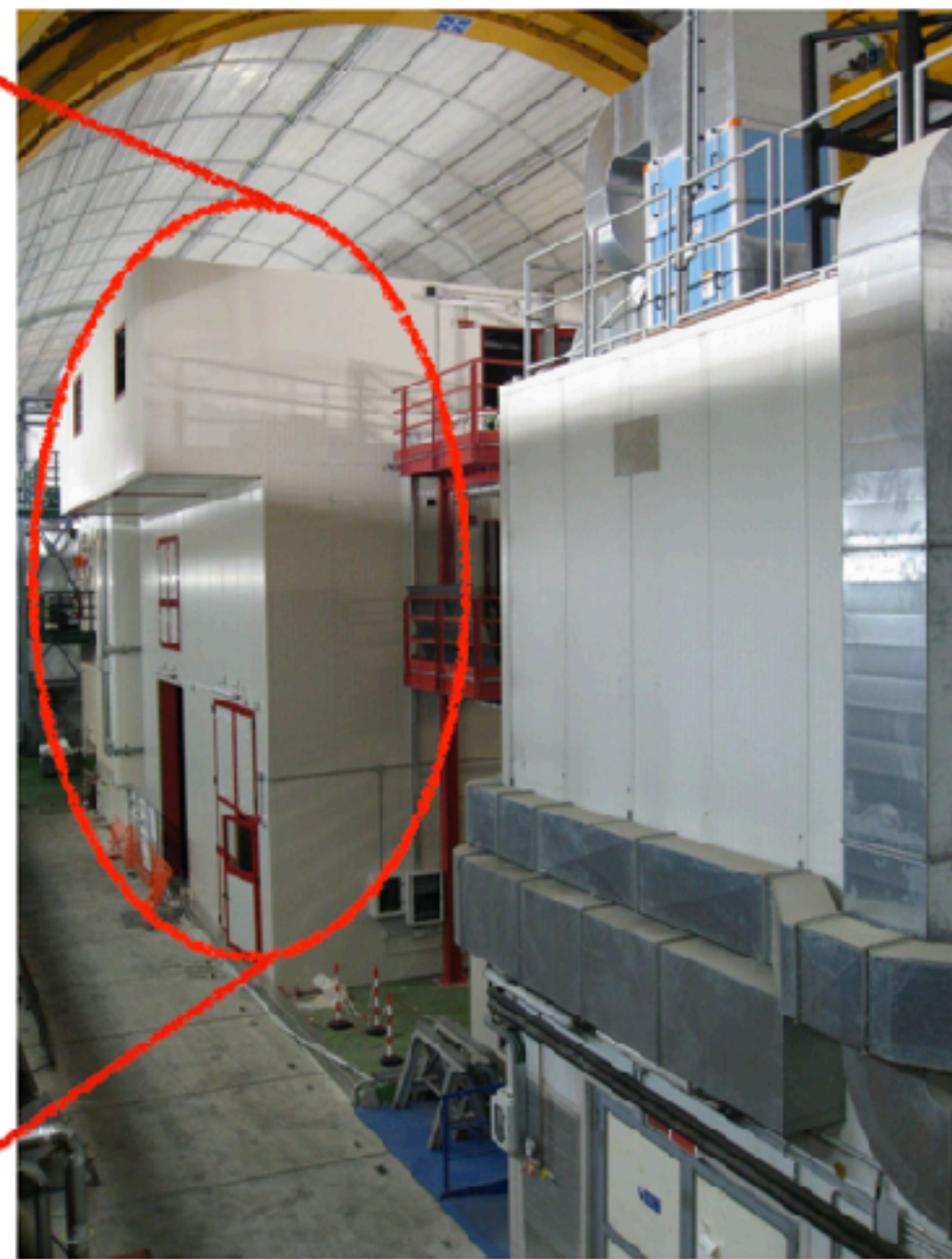
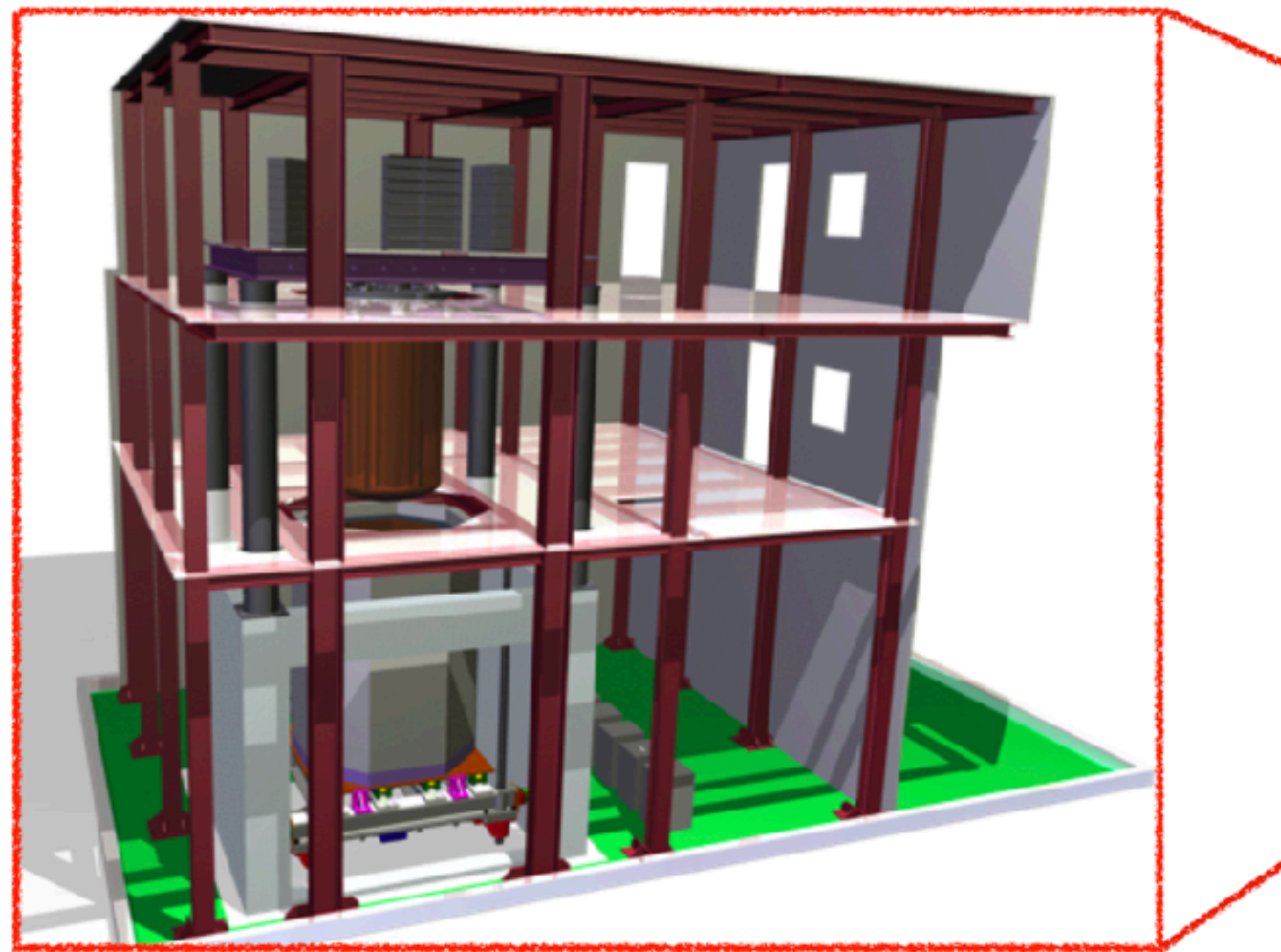

Alla ricerca del $0\nu\beta\beta$ con l'esperimento CUORE

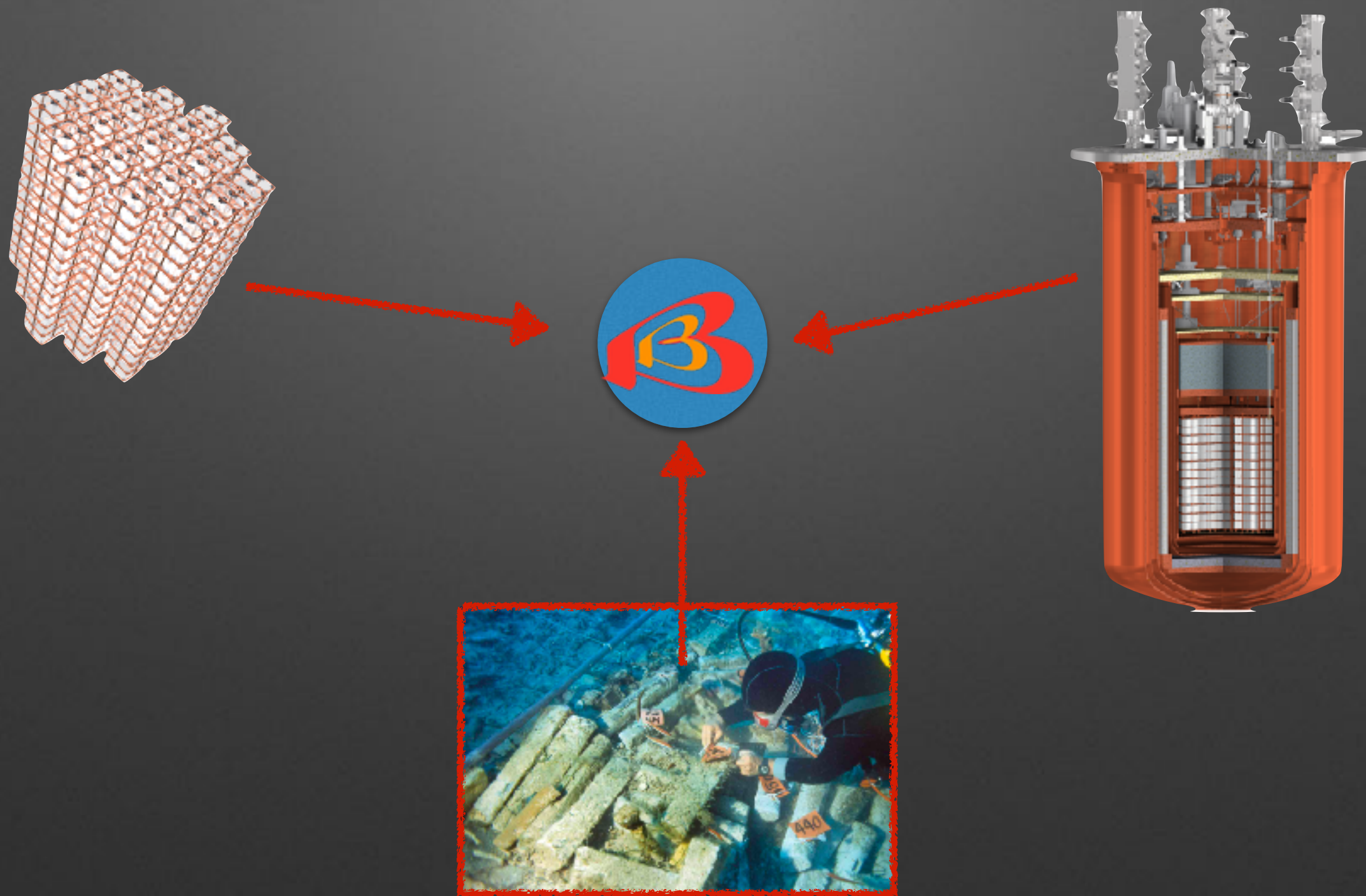

La tecnica bolometrica

❄️ 10 mK = -273,14 °C

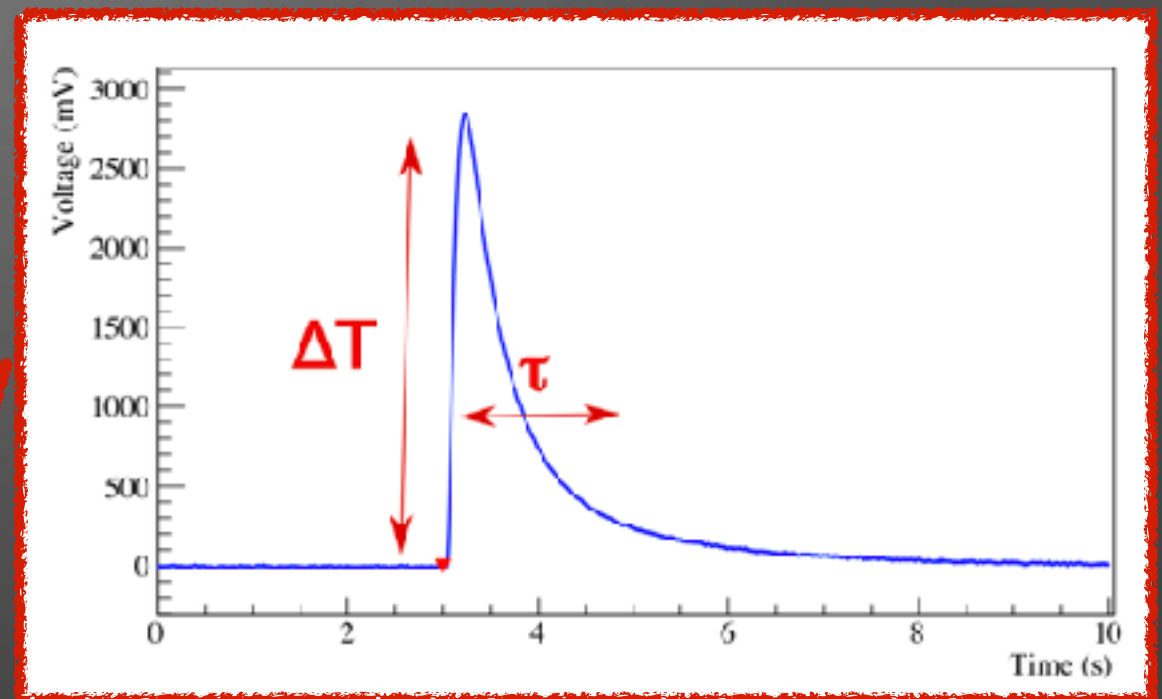
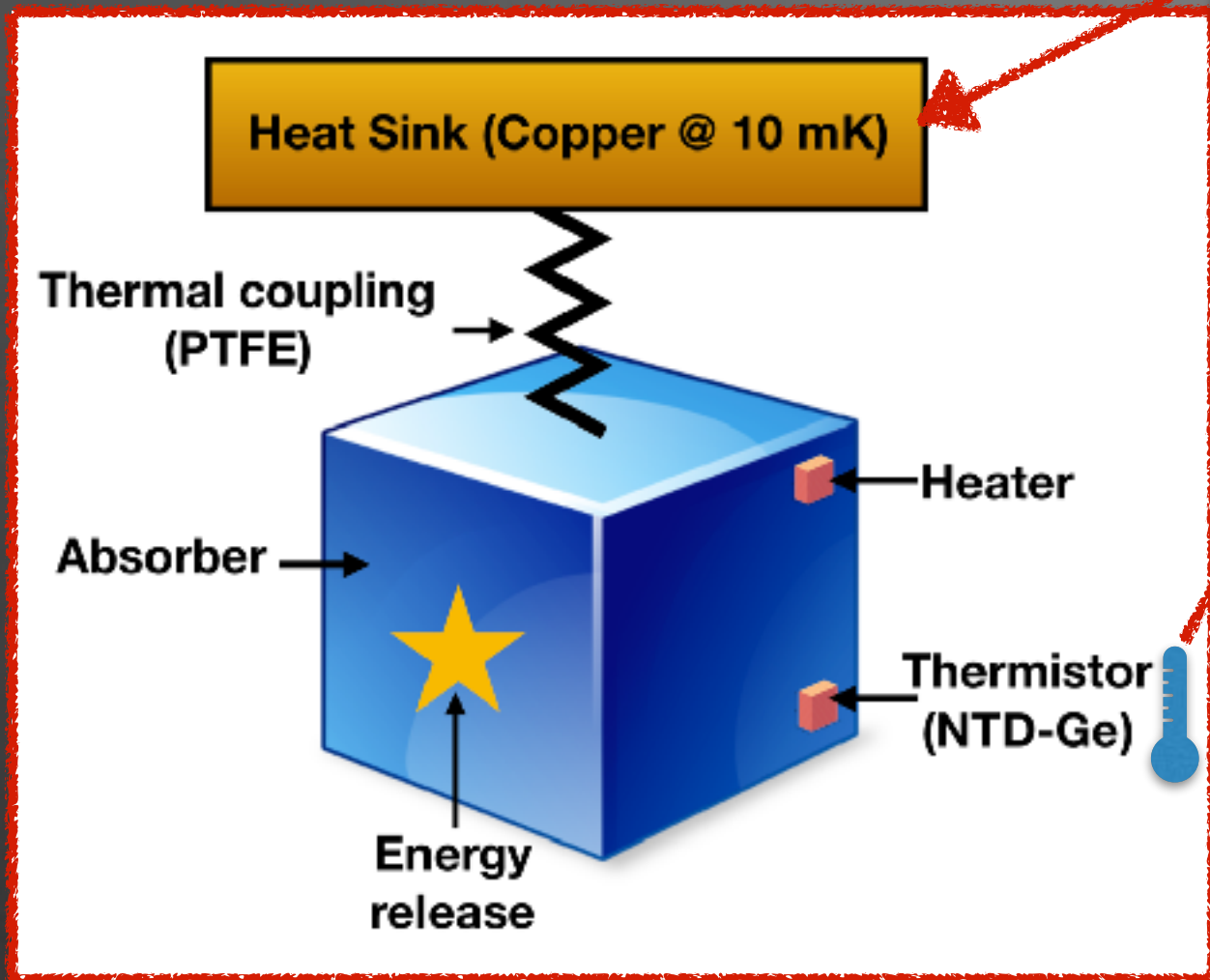

- Il decadimento dentro il cristallo causa un aumento di temperatura, che viene rivelata da un termometro

I cristalli

- Cristalli di TeO_2
(^{130}Te candidato $0\nu\beta\beta$)
- $5 \times 5 \times 5 \text{ cm}^3$
(750 g)
- Termometro:
 $10\text{-}20 \mu\text{K/MeV}$

Tanta massa



988 cristalli

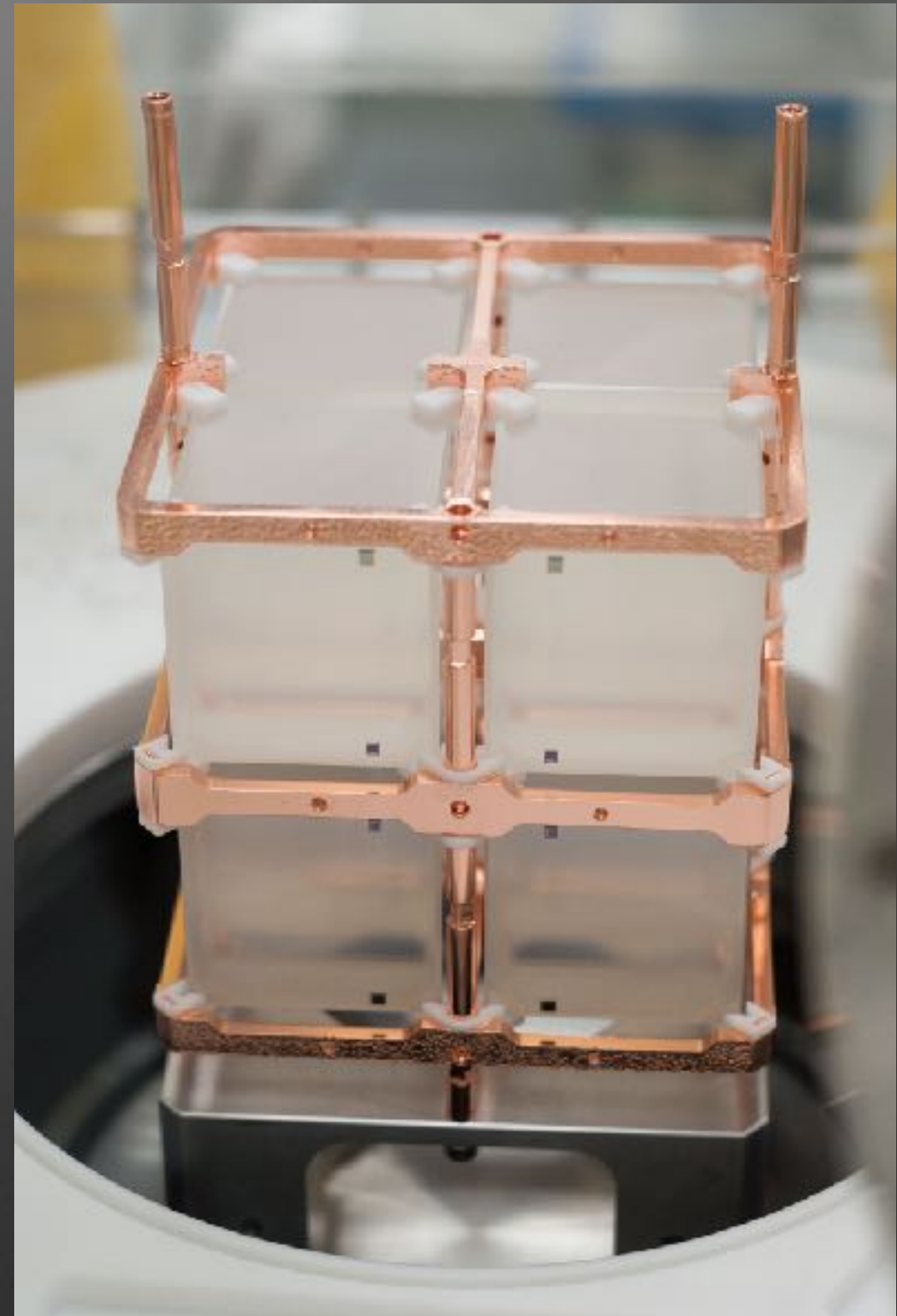

La costruzione della torre

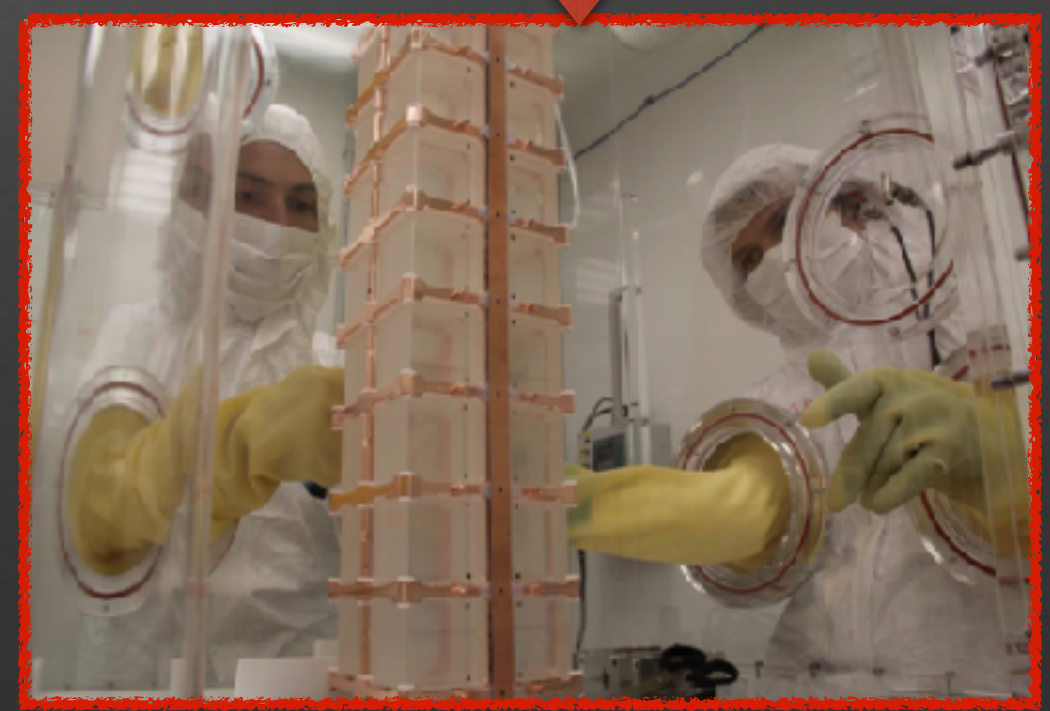
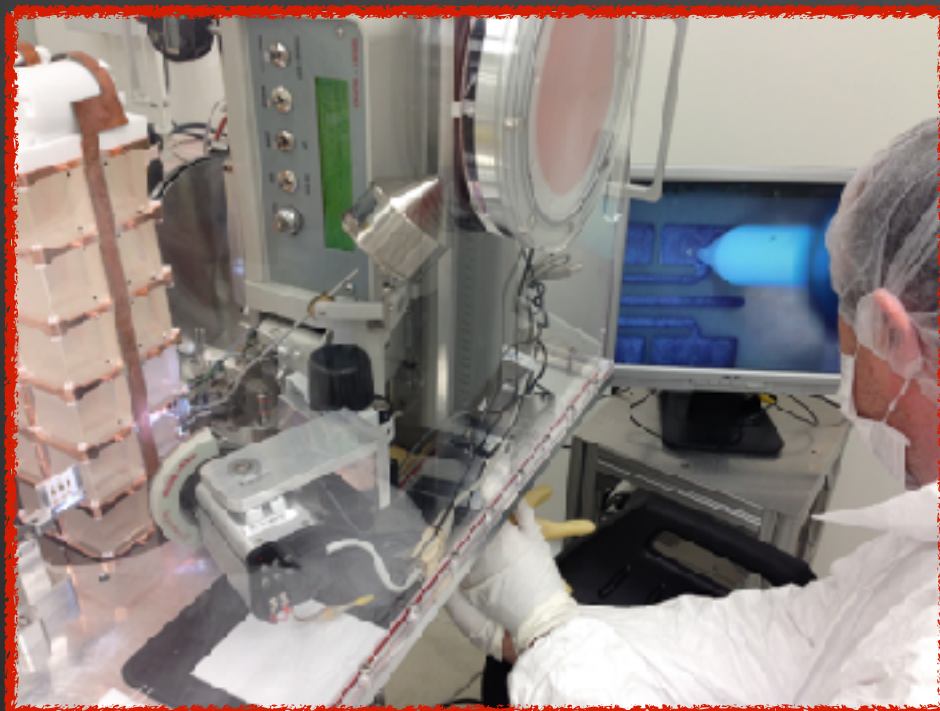
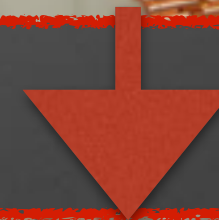
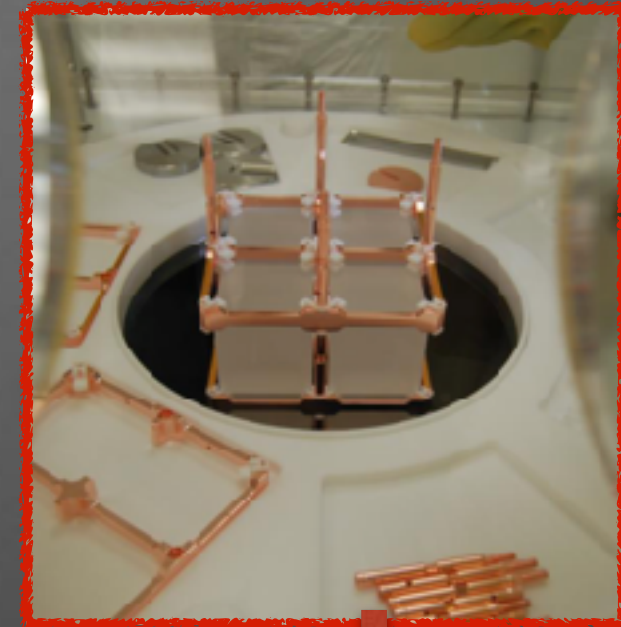

L'installazione delle torri

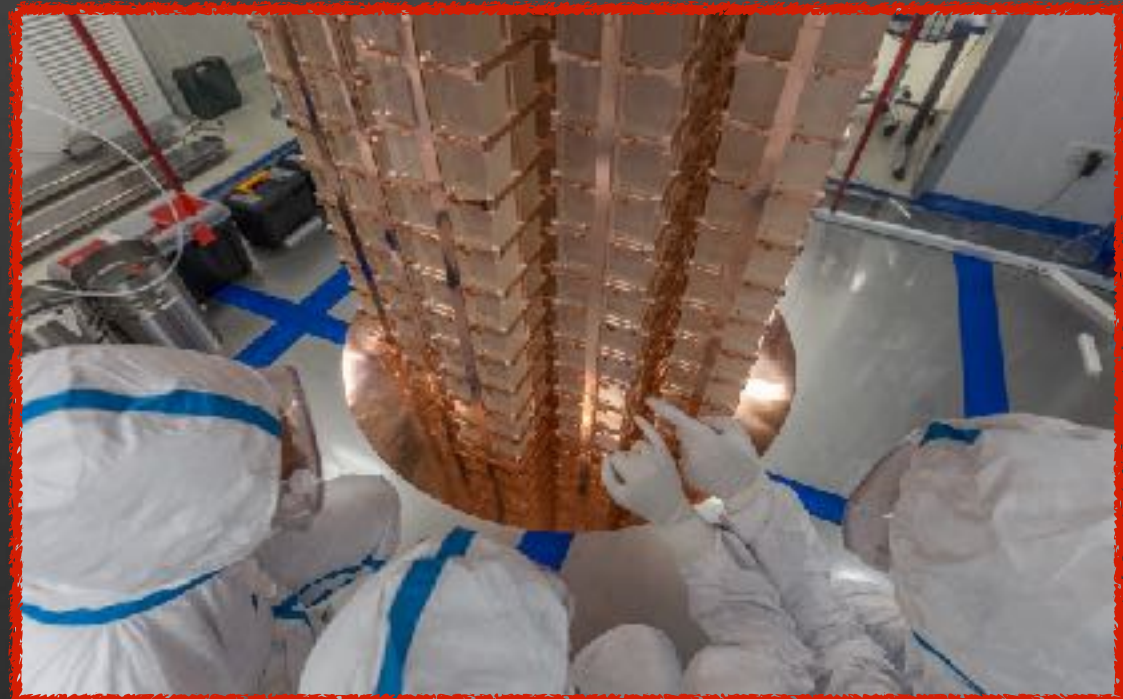
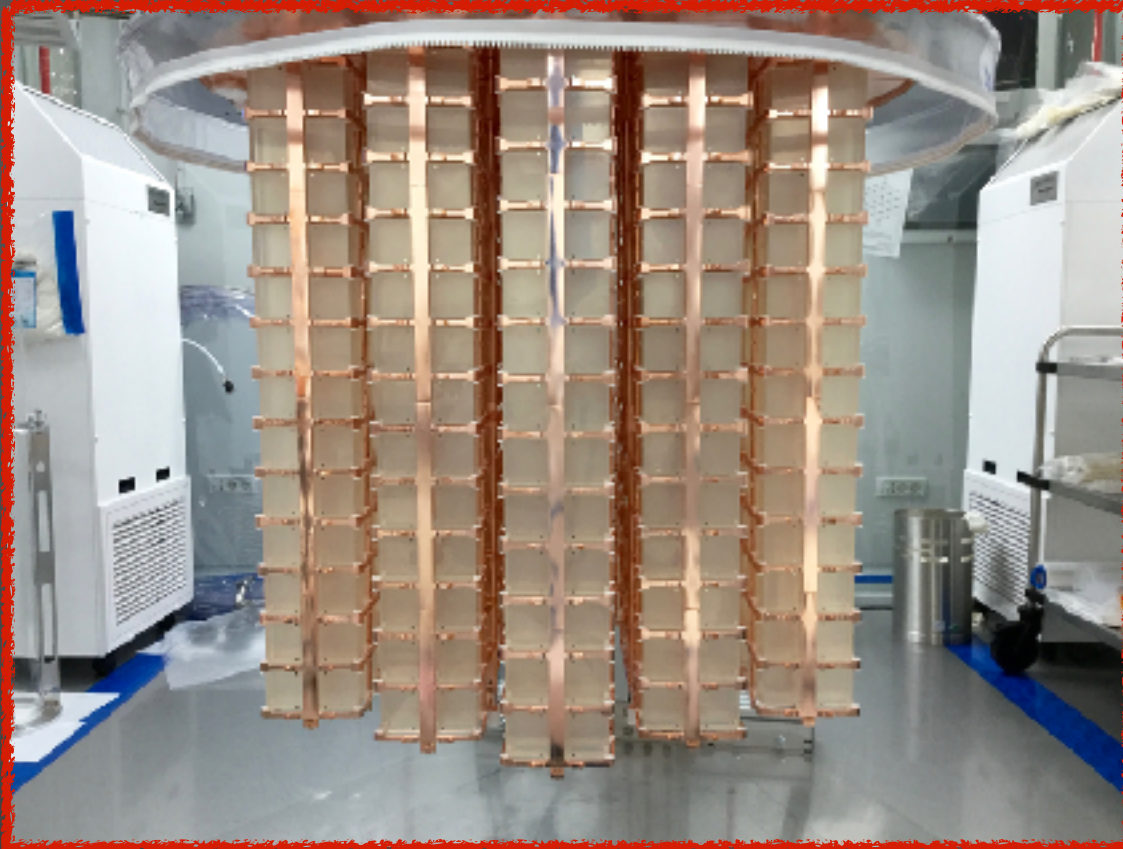

**Costruzione completata
26/08/2016**

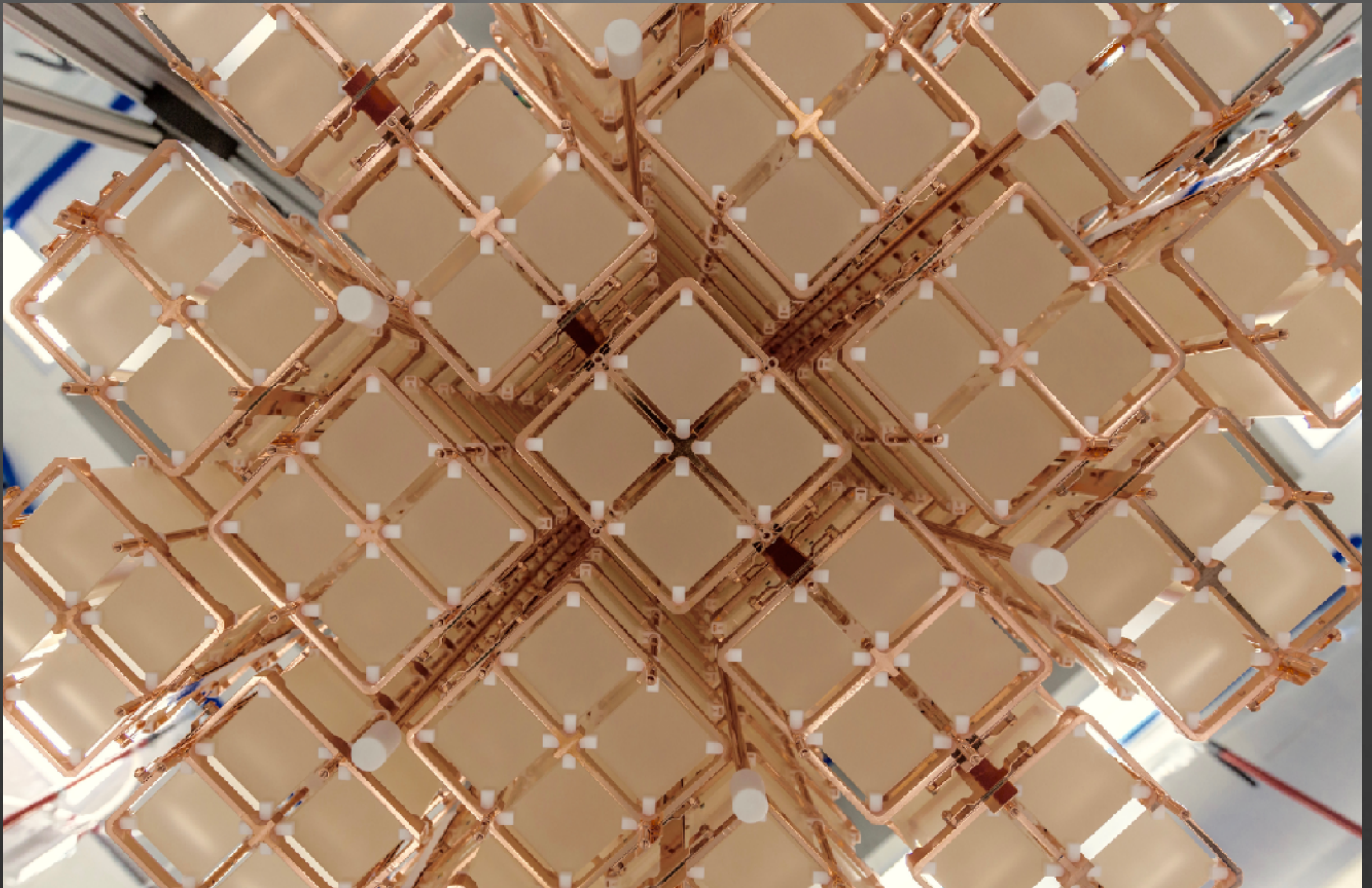

Il criostato

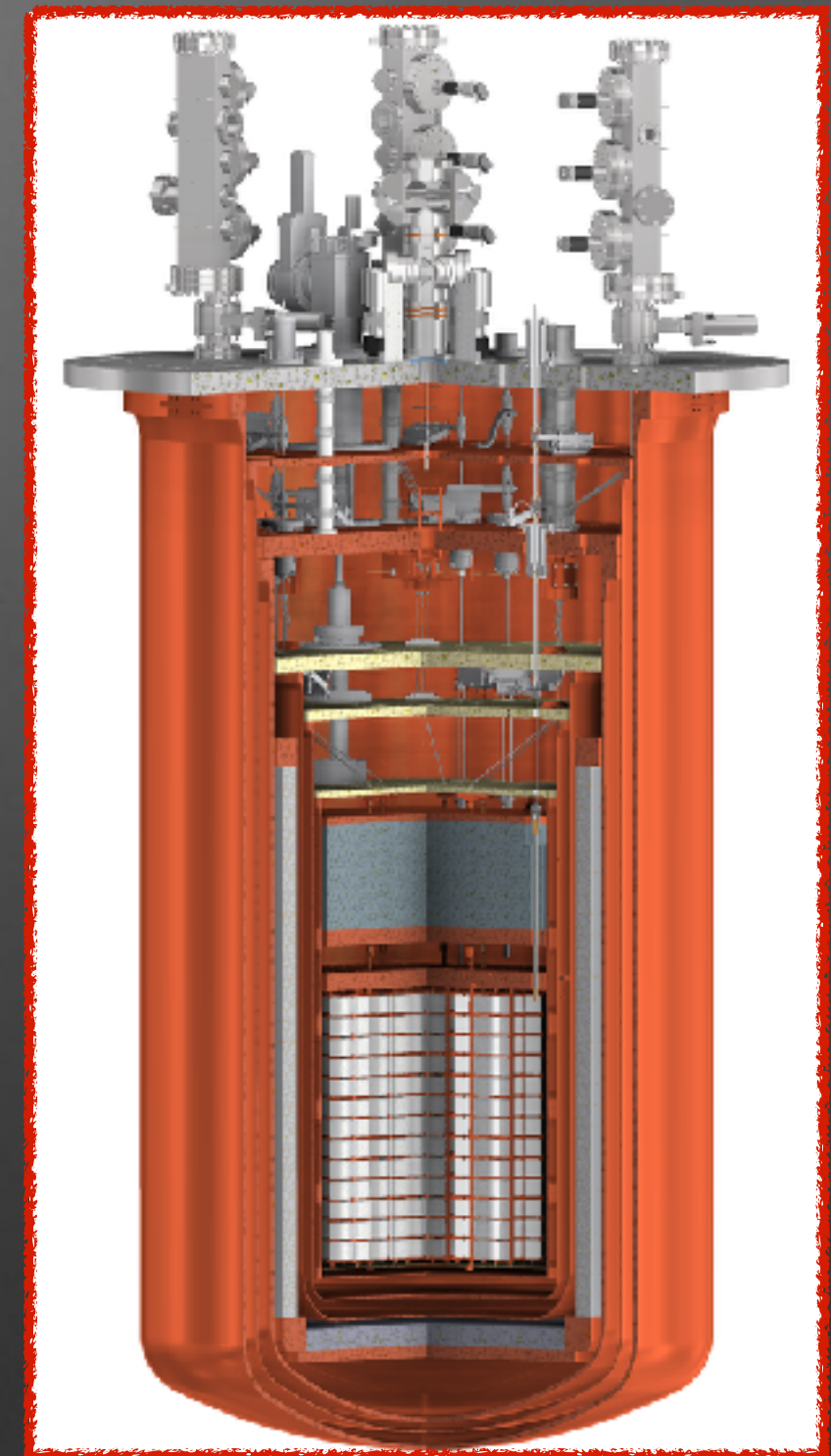
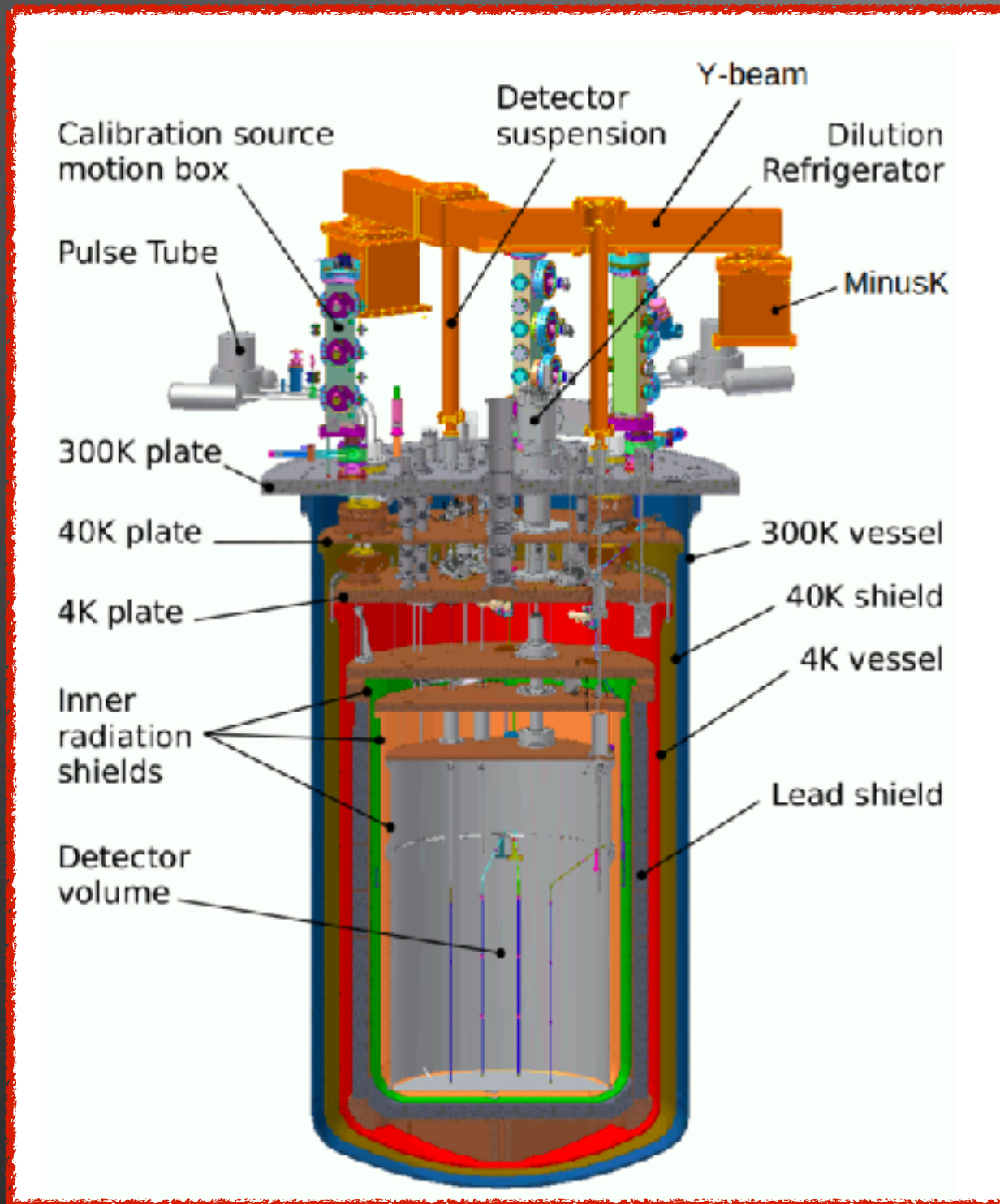

Isolamento termico

Conduzione



Convezione



Isolamento
termico

Irraggiamento



Il criostato

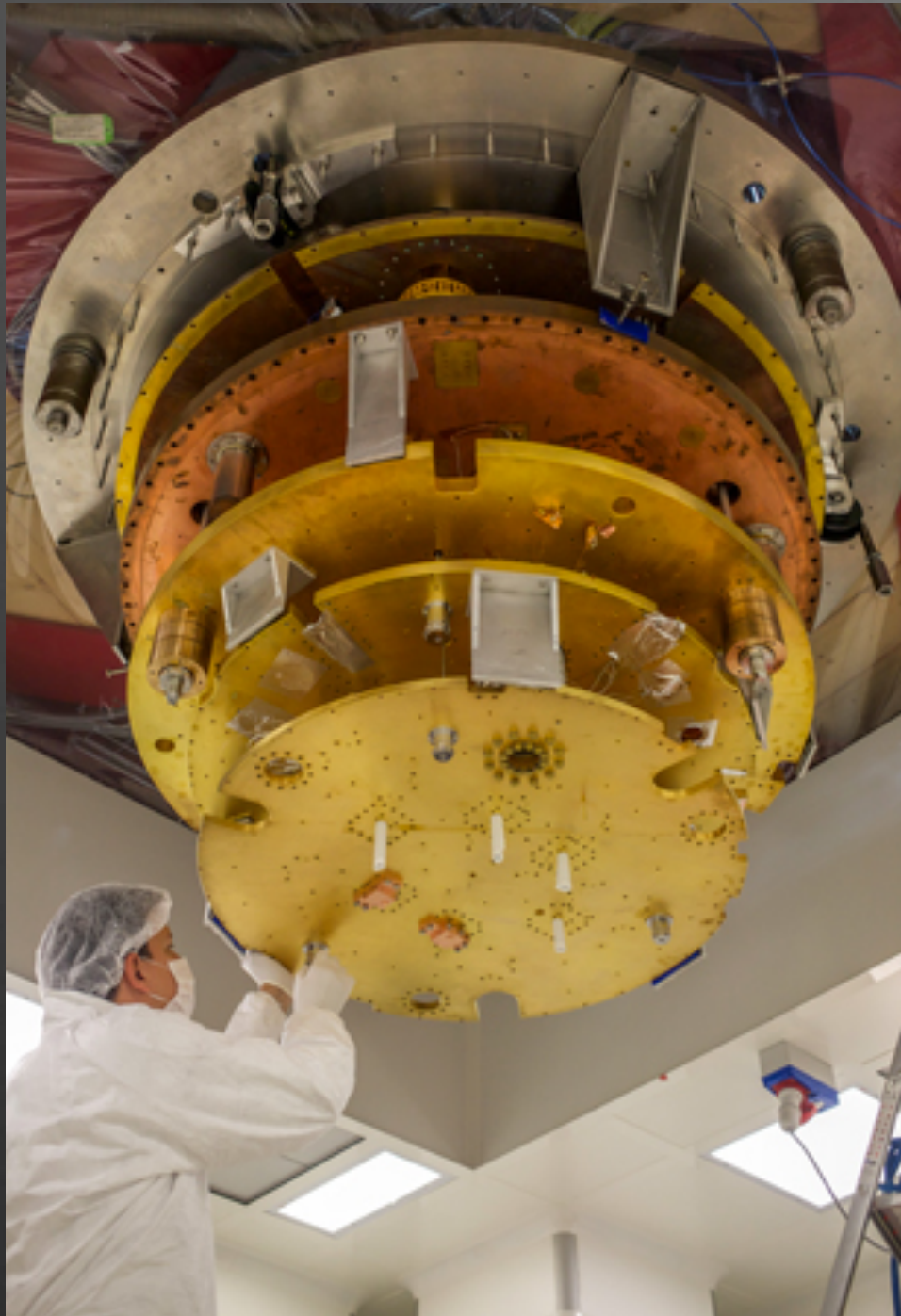

Il criostato

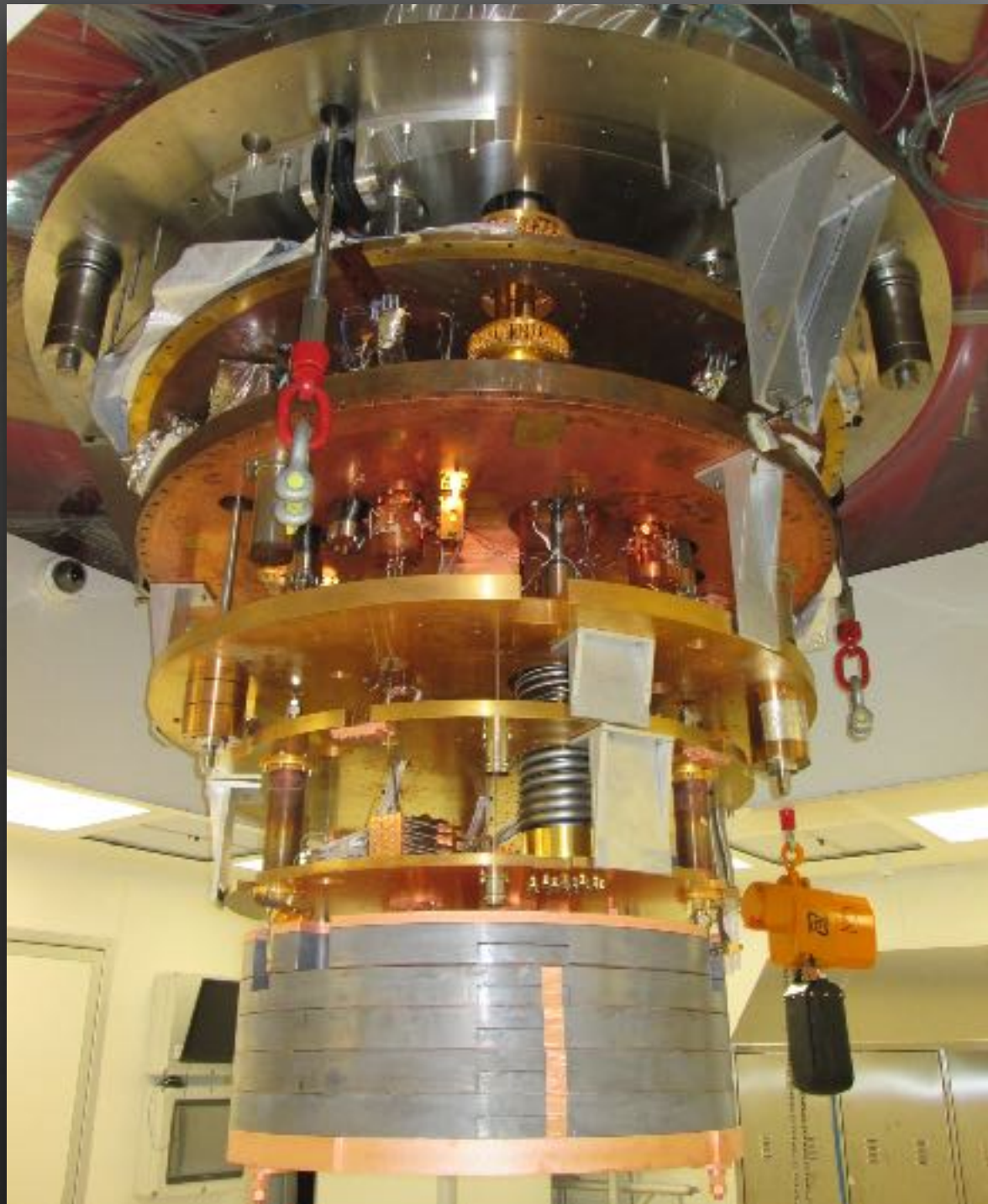

Piombo romano

- Collaborazione INFN-Sovrintendenza ai Beni Culturali di Cagliari
- 80-50 a.C.
- Provenienti miniera Cartagena
- 46 cm 33 kg
- Il piombo è stato protetto dai raggi cosmici negli ultimi 2000 anni -> no ^{210}Pb

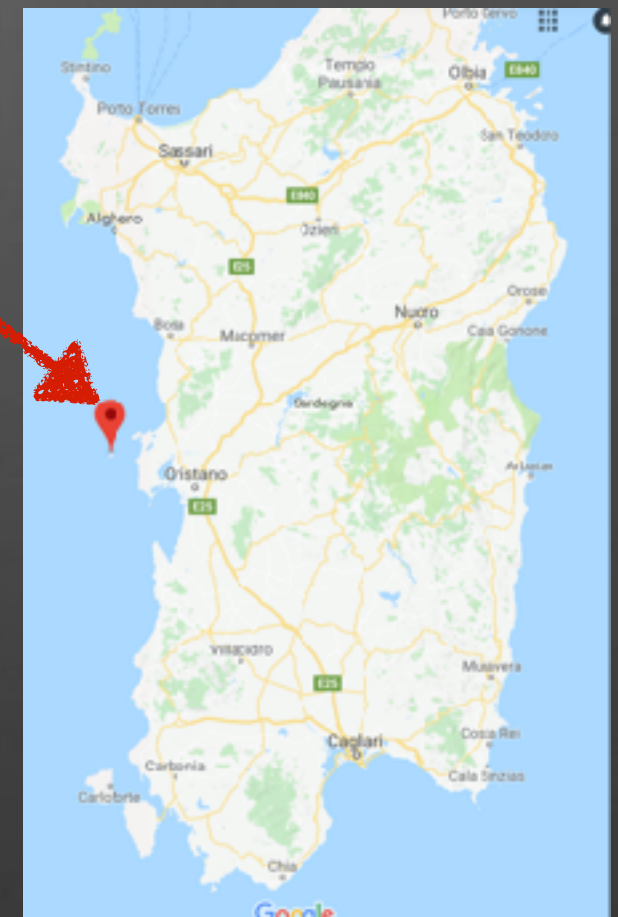

Piombo romano



Piombo romano

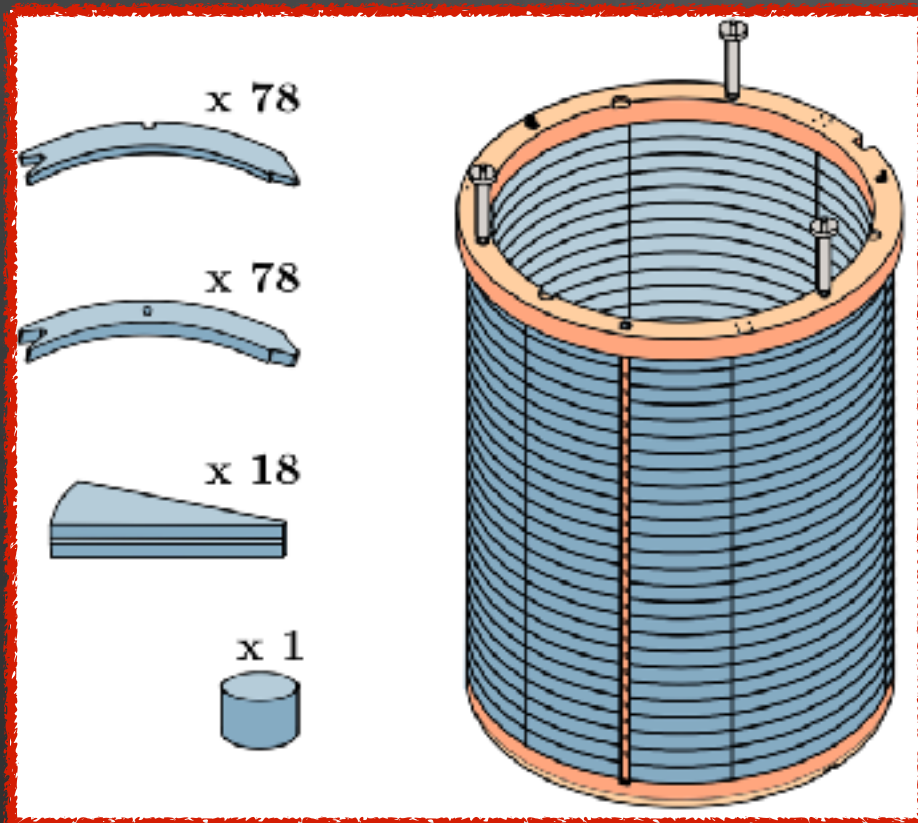

La fine della costruzione e i primi dati

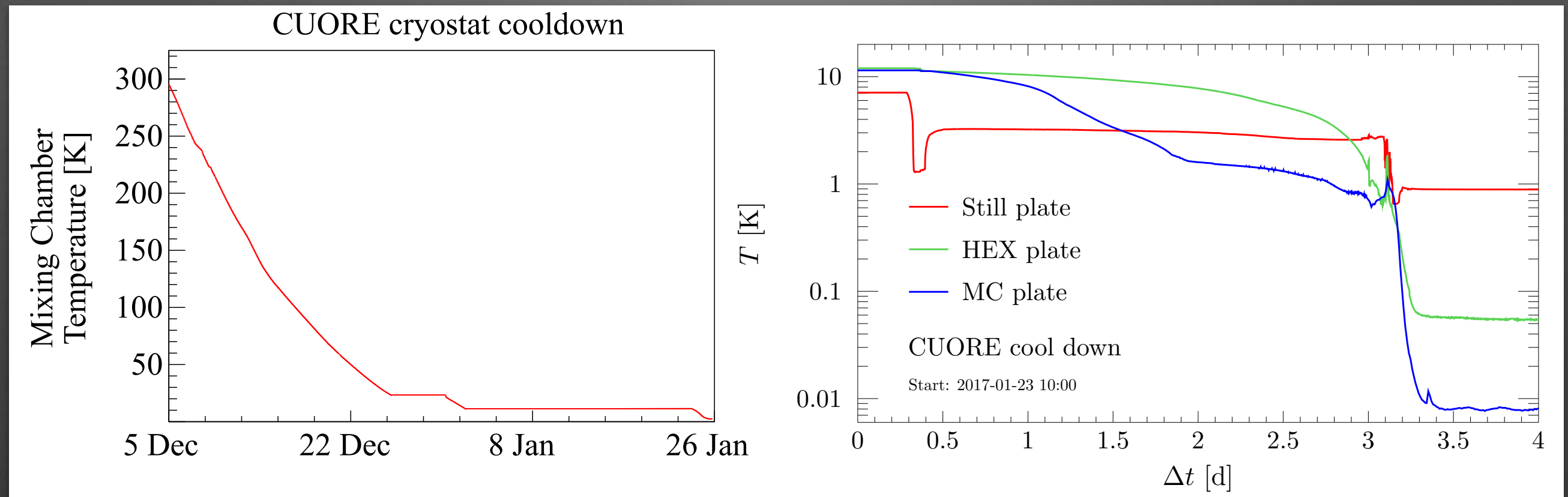

- Sono stati necessari un paio di mesi a fine 2016 inizio 2017 per il raffreddamento del criostato e per test di funzionamento del sistema

La fine della costruzione e i primi dati

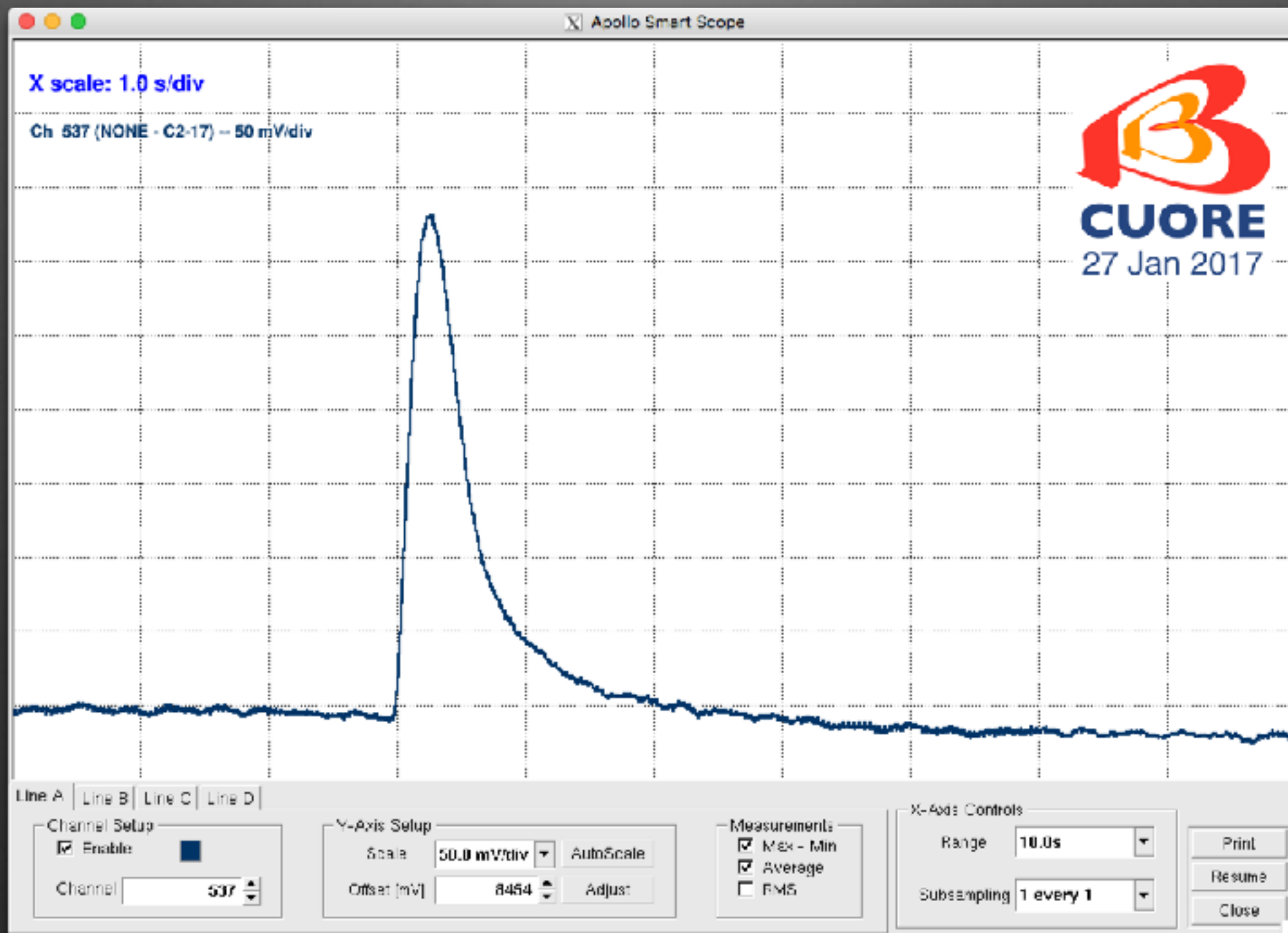

La fine della costruzione e i primi dati

Maggio 2017, inizio del run scientifico



Prima di mostrarvi gli ultimi risultati....

un piccolo excursus sulla mia esperienza all'interno della
collaborazione

La mia esperienza all'interno dell'esperimento

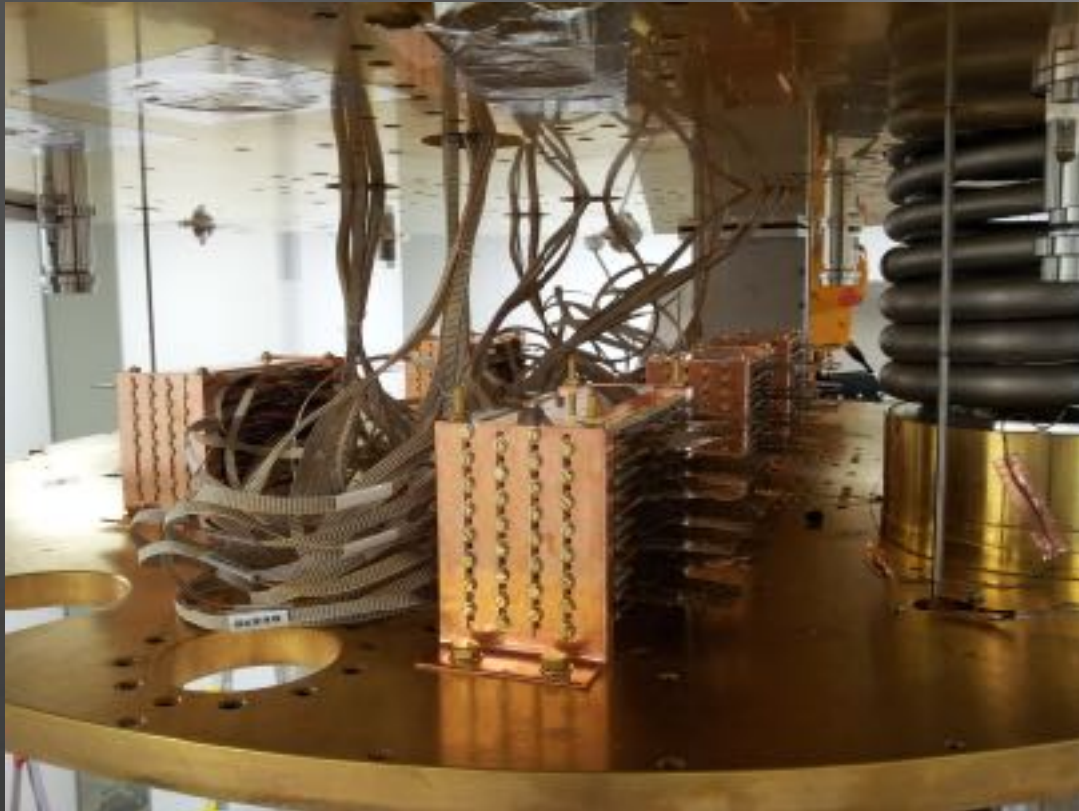

La mia esperienza all'interno dell'esperimento

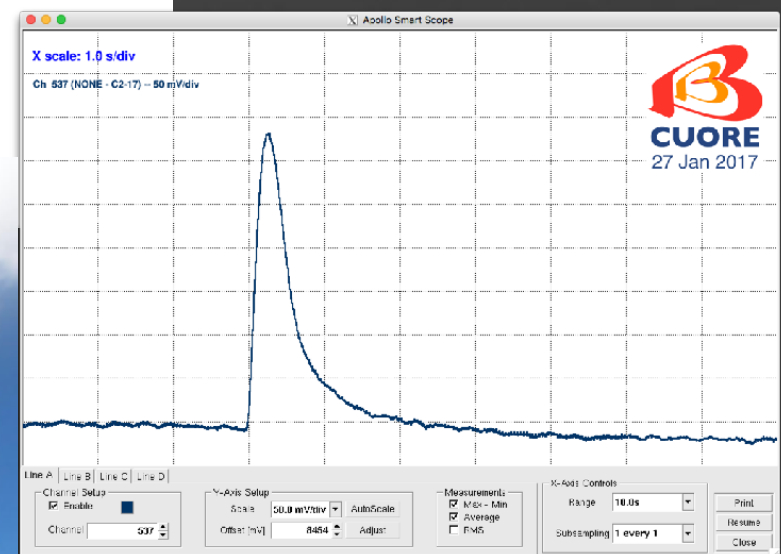

L'analisi dati

Dalla teoria alla realtà...

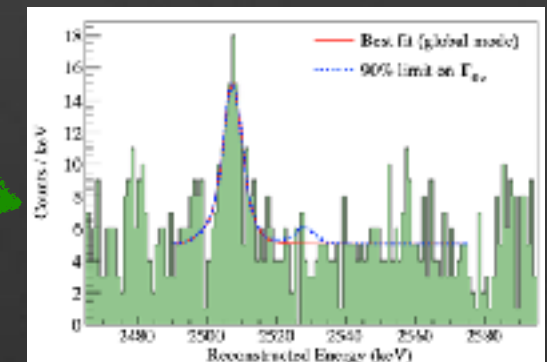
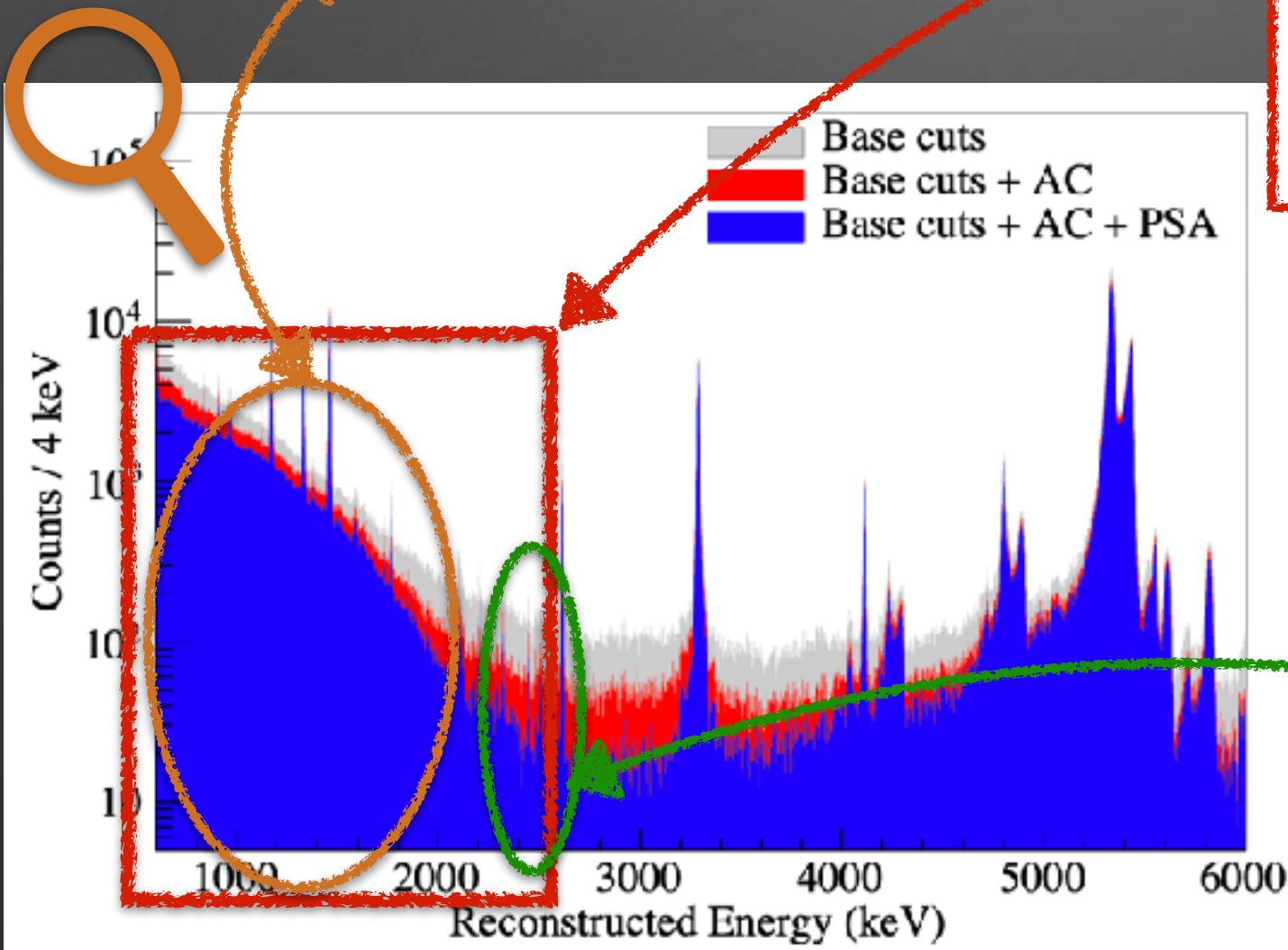
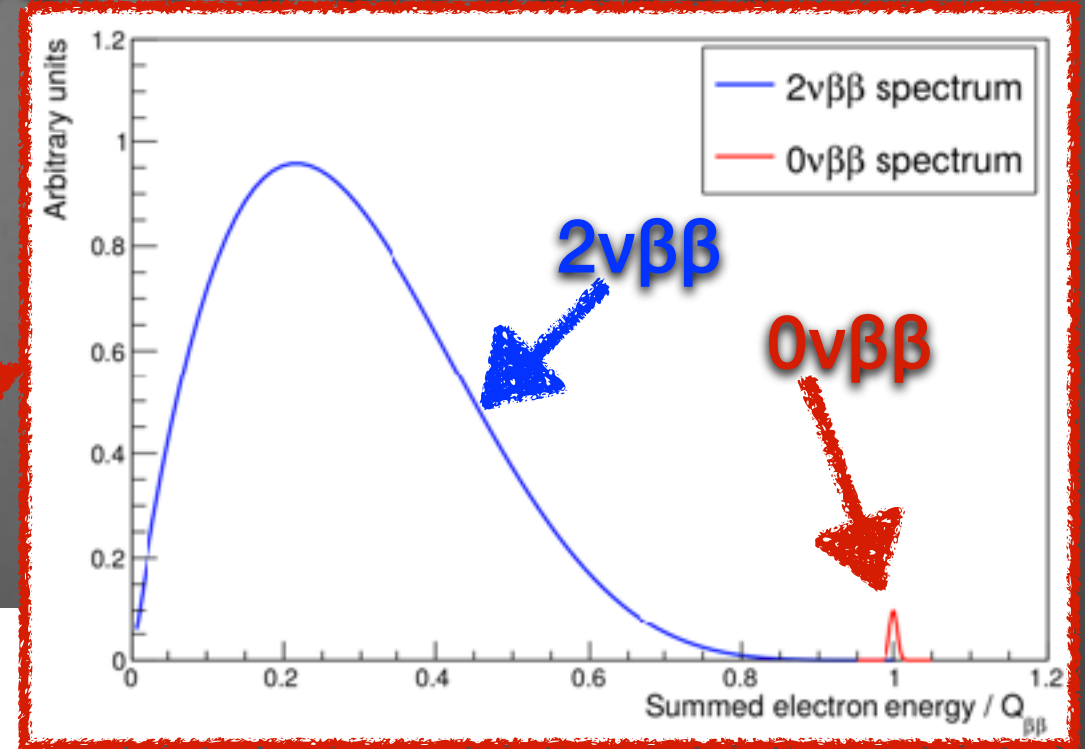
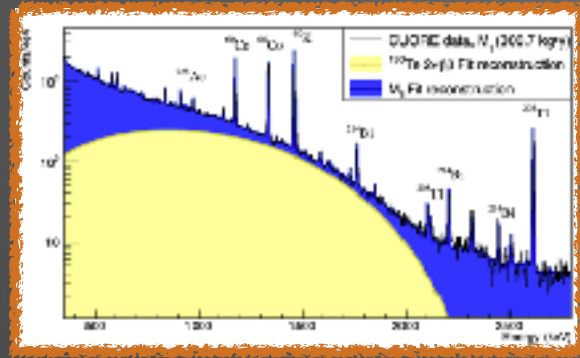

I risultati

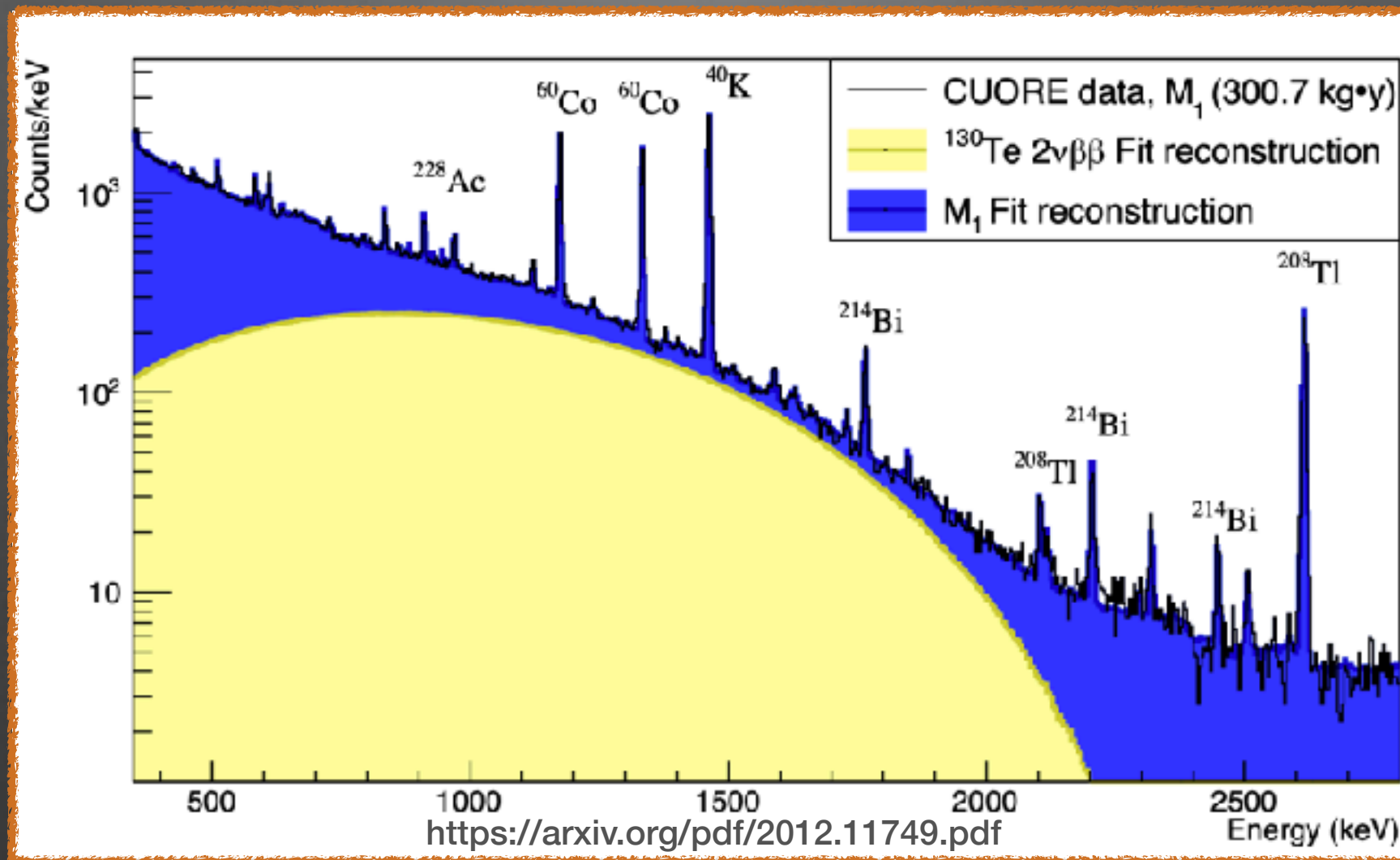

- $T_{1/2} = 7.71^{+0.08}_{-0.06}(\text{stat.})^{+0.12}_{-0.15}(\text{syst.}) \times 10^{20} \text{ yr}$

I risultati

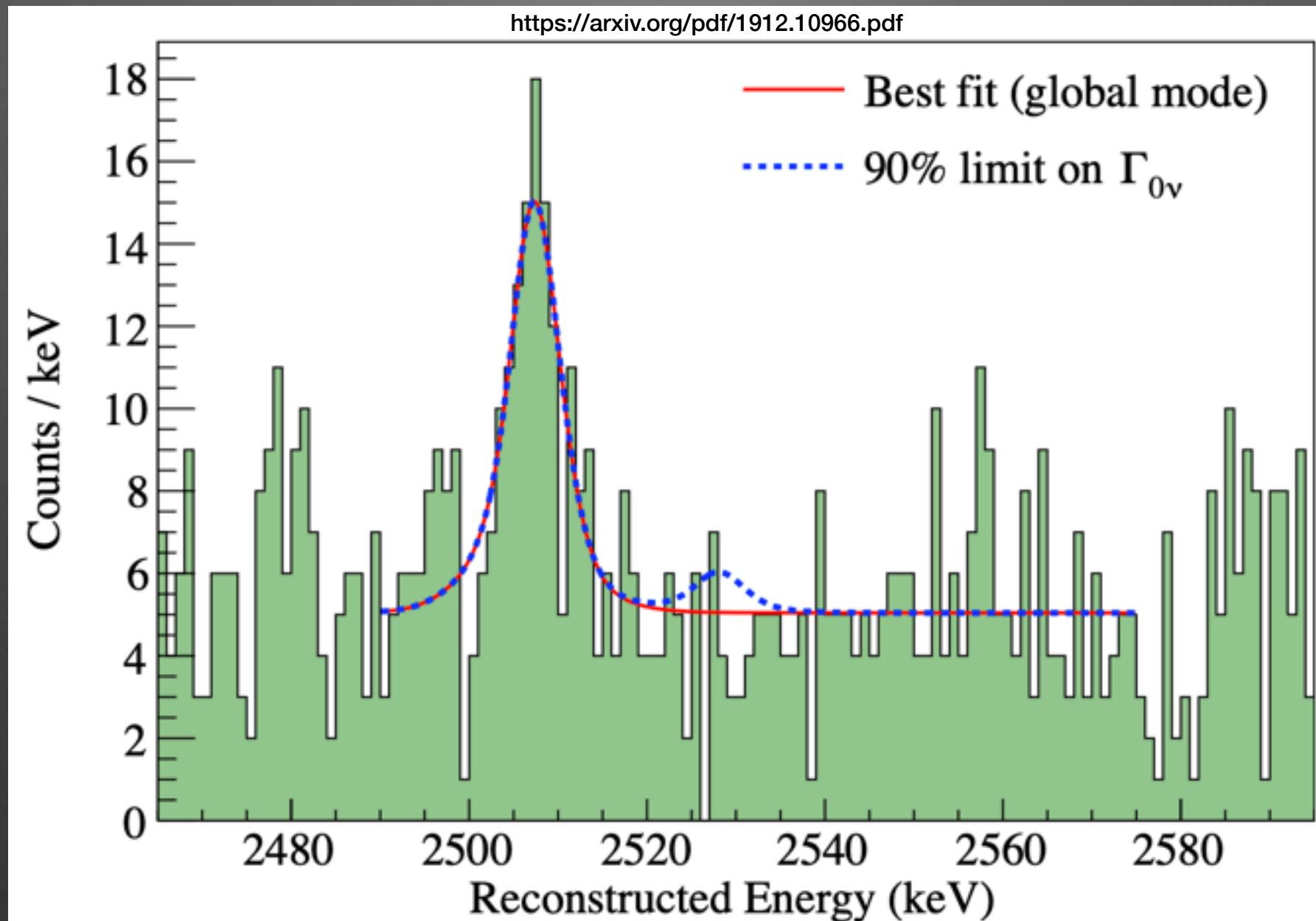

- $T_{1/2}^{0\nu} > 3.2 \times 10^{25} \text{ yr}$

Una lunga storia di ricerche e sviluppo tecnologico

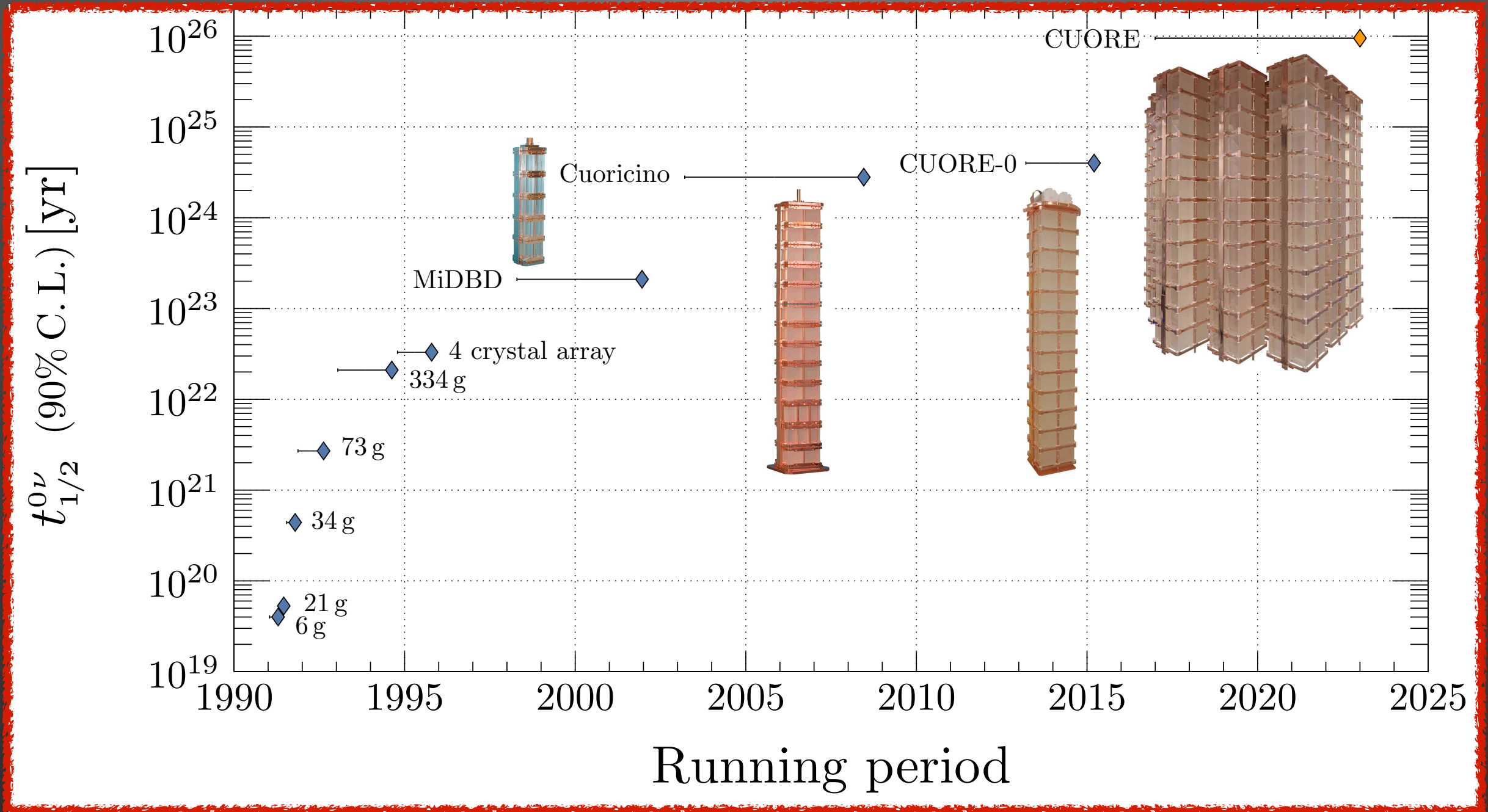

Conclusioni

- CUORE sta dando importanti informazioni sull'esistenza del $0\nu\beta\beta$
- Se il decadimento venisse rivelato darà:
 - Indicazioni fondamentali sulla massa del neutrino
 - Prova che il neutrino è una particella di Majorana
 - Evidenza di non conservazione del numero leptonico



Still much to
discover...

Grazie per l'attenzione