

# Noise Test oL1

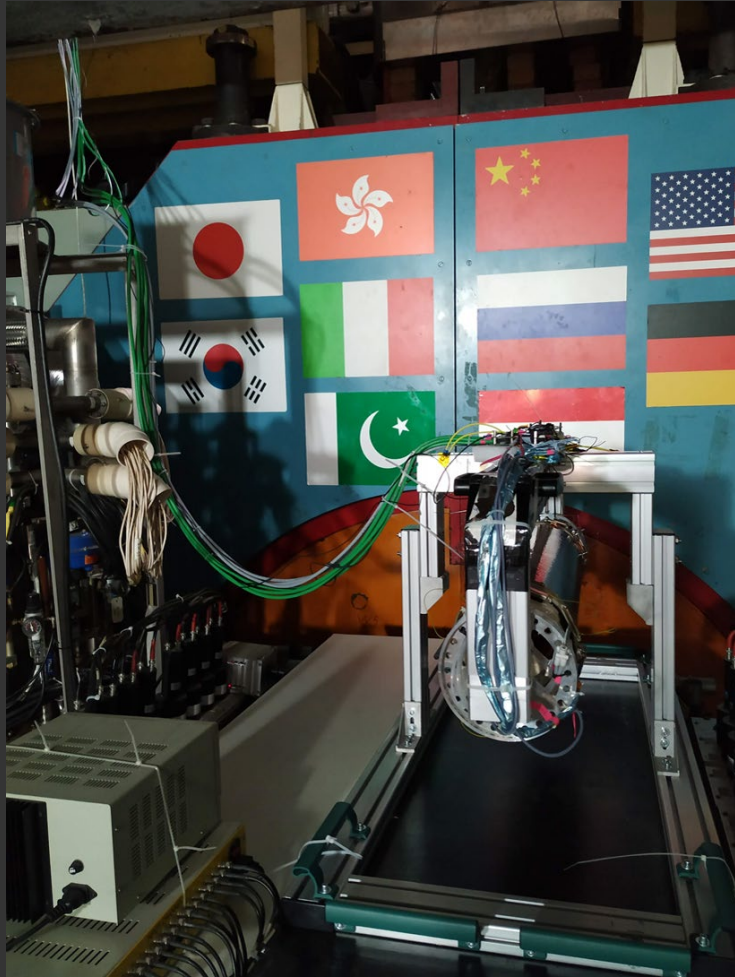

# Outline



## Introduction

Aims of the test

Timeline

Setup and grounding

## Measurement

Threshold scan

noise distribution

T and E branches

External factors

## Data and operations

Regrounding operations

Shielding operations

Beam stability issues

## Conclusion

Summary and roadmap

Outlook



---

# Introduction

# Aims of the test

**Assessment of the noise induced by:**

- Accelerator
- Beam
- Experiment

**Grounding Studies**

# Timeline

-  Maintenance shutdown
-  Synchrotron radiation production
-  Data taking

## October



## November



## December

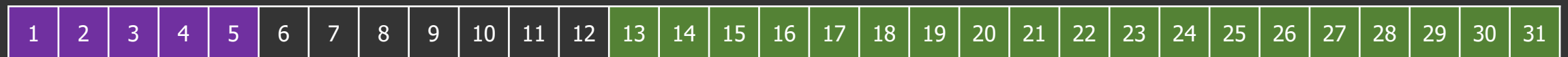

# Setup

- Power
- Power + Signal
- Ground
- Ethernet

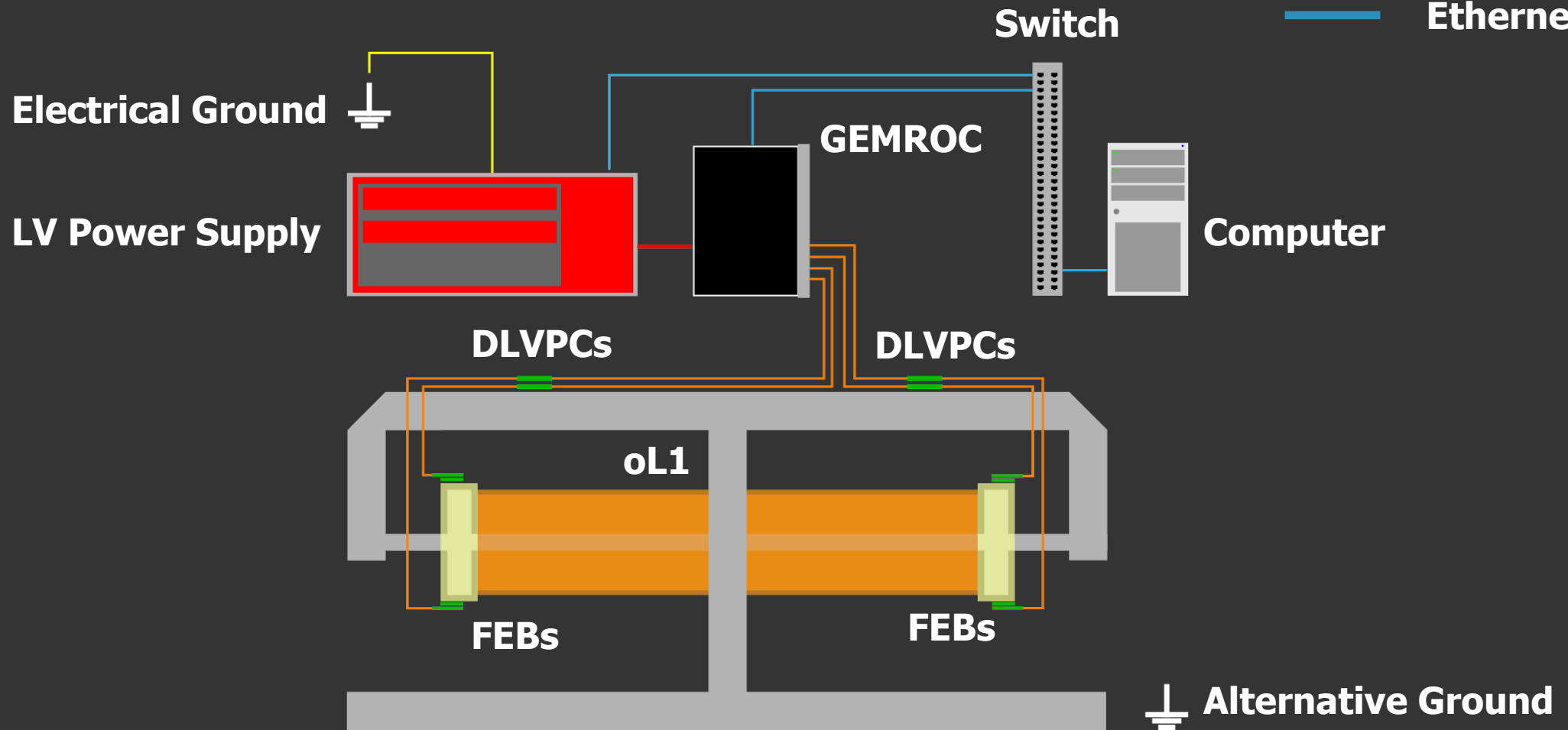

# Grounding

- Power
- Power + Signal
- Ground
- Ethernet

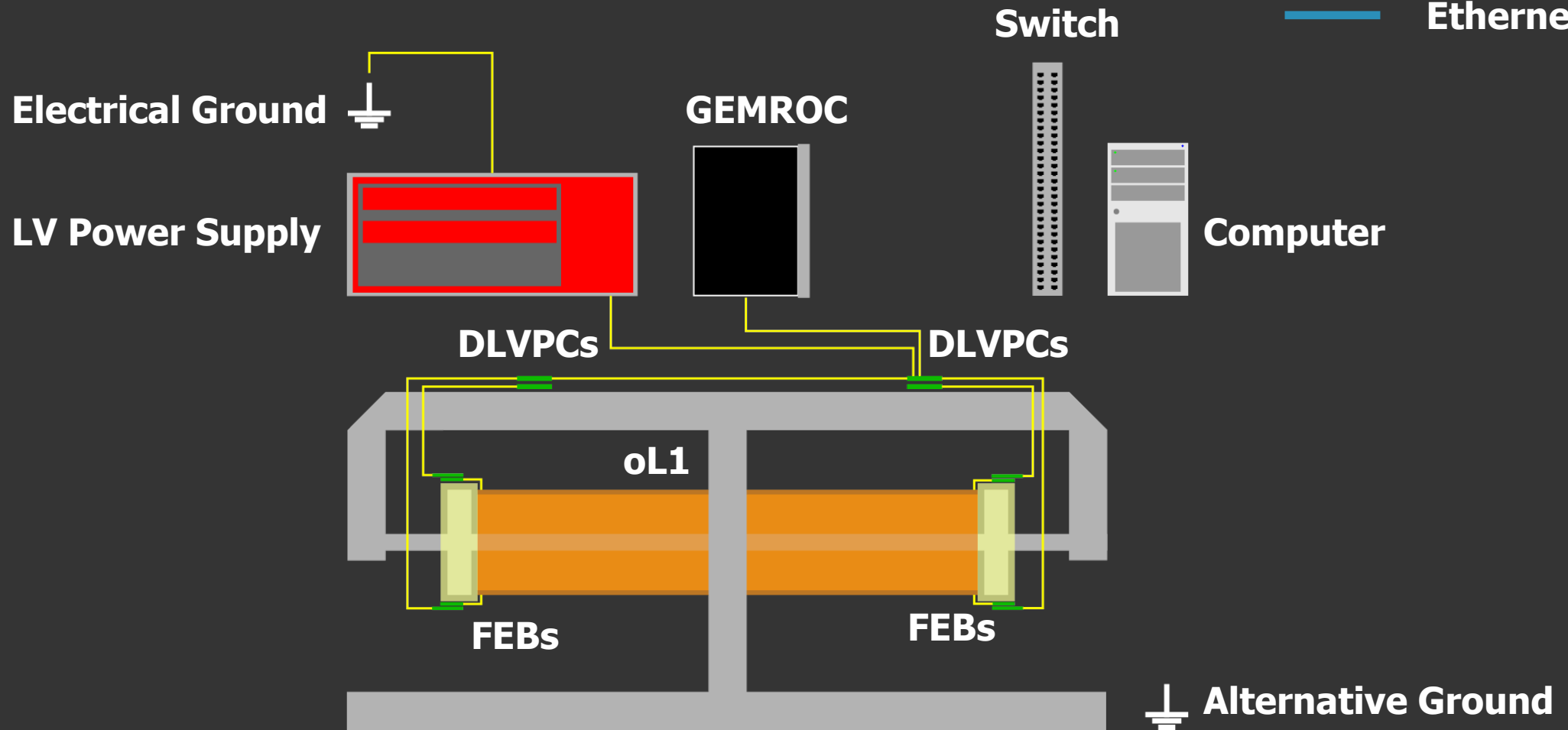



# Measurement



# Threshold Scan

Each threshold step is 0.5 fC

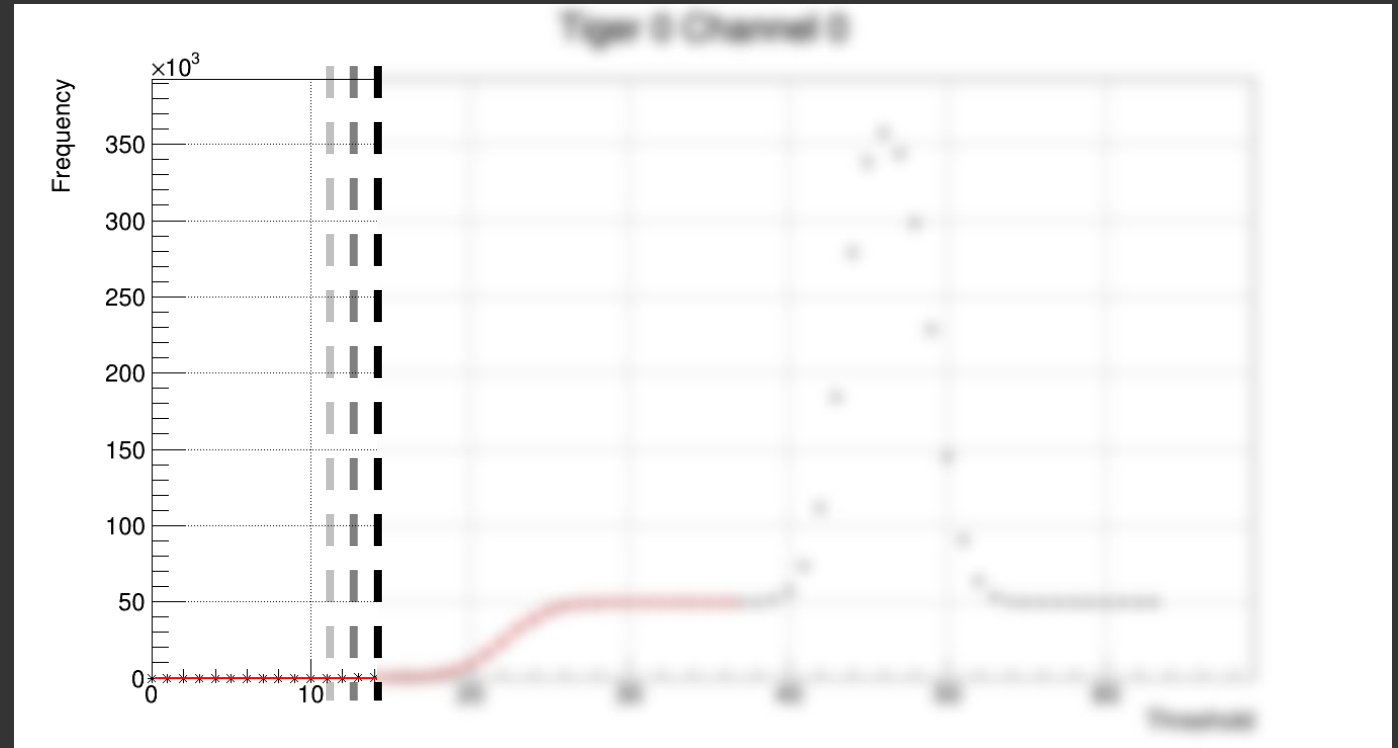
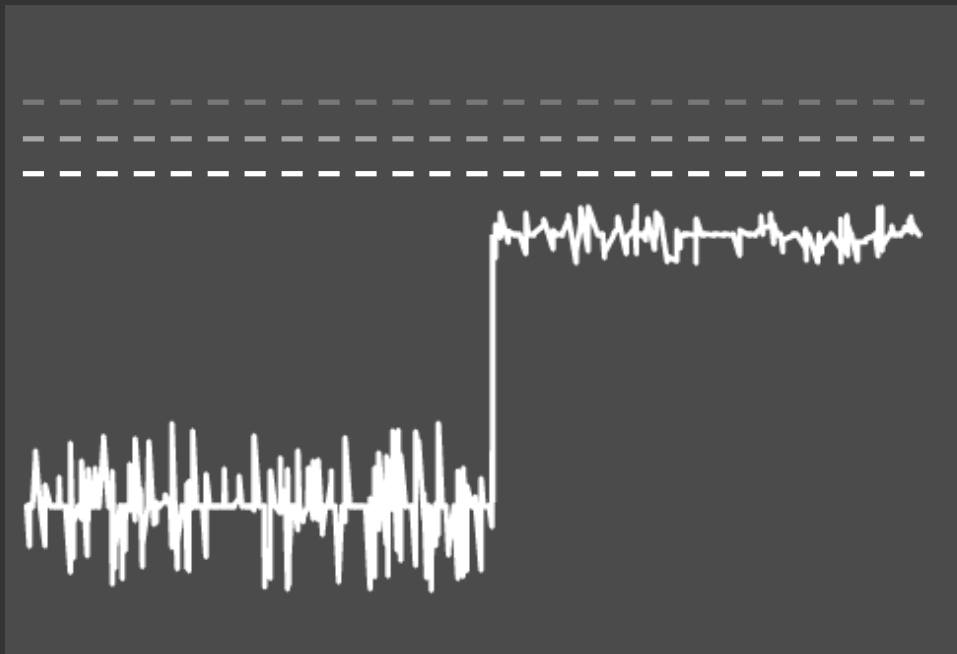

The number of threshold crossings in 1/10 of a second is registered

# Threshold Scan

Each threshold step is 0.5 fC

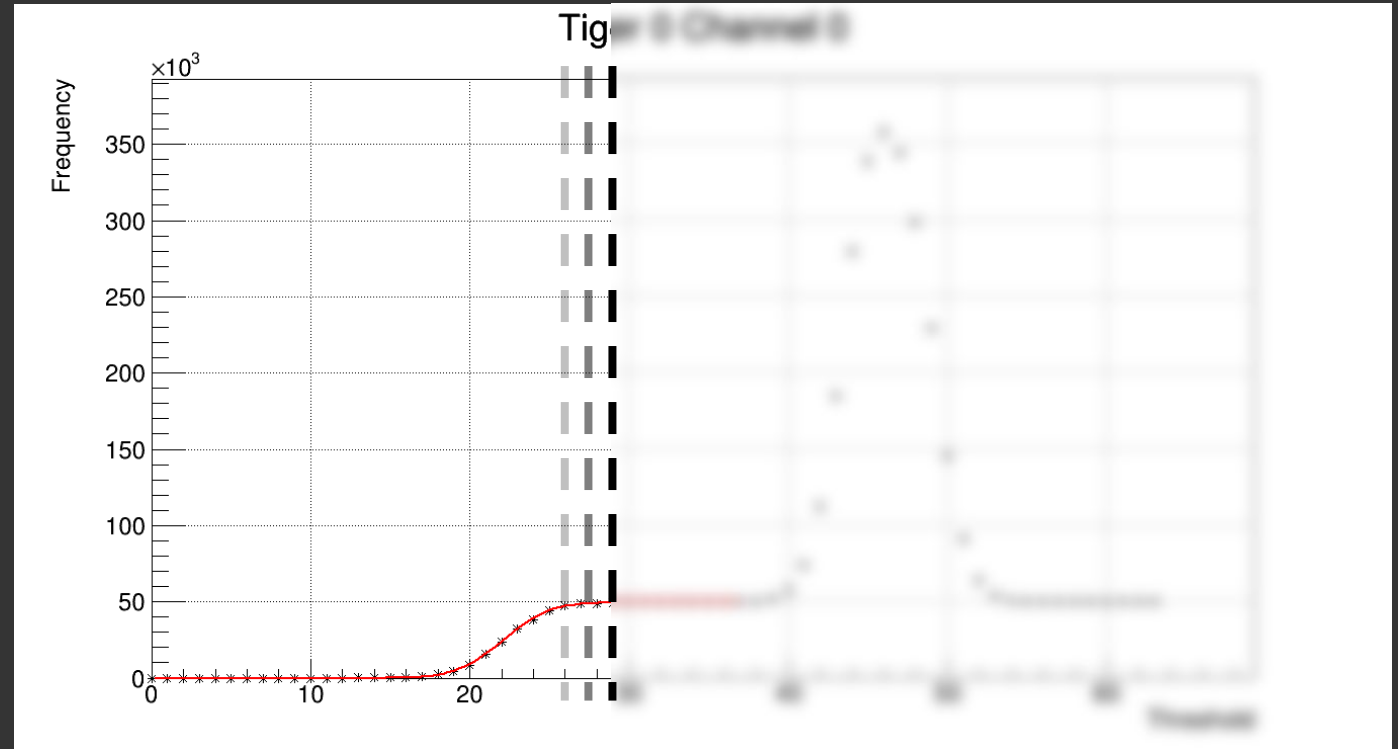
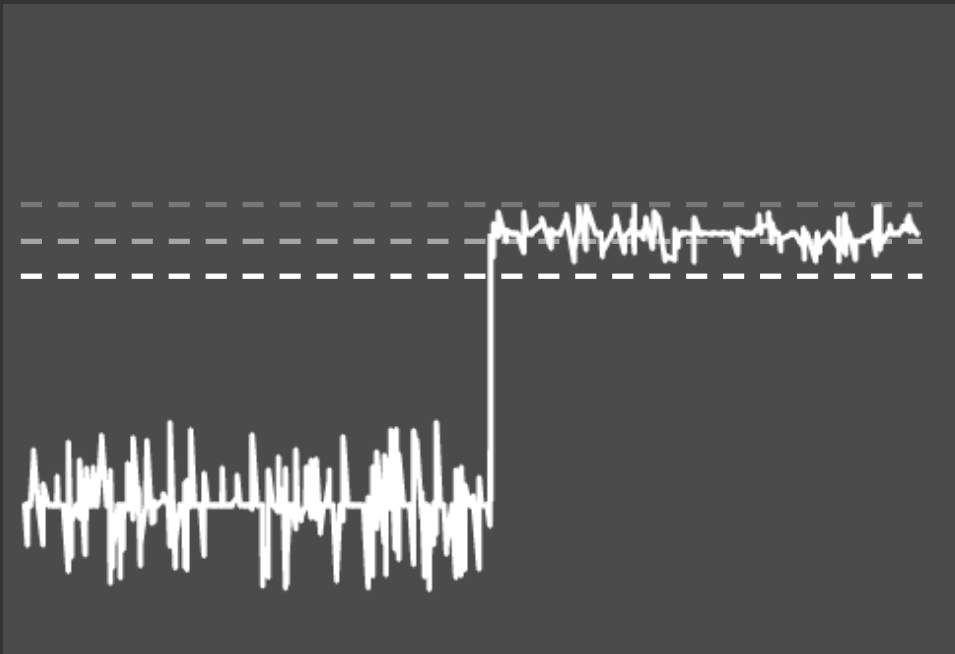

The number of threshold crossings in 1/10 of a second is registered

# Threshold Scan

Each threshold step is 0.5 fC

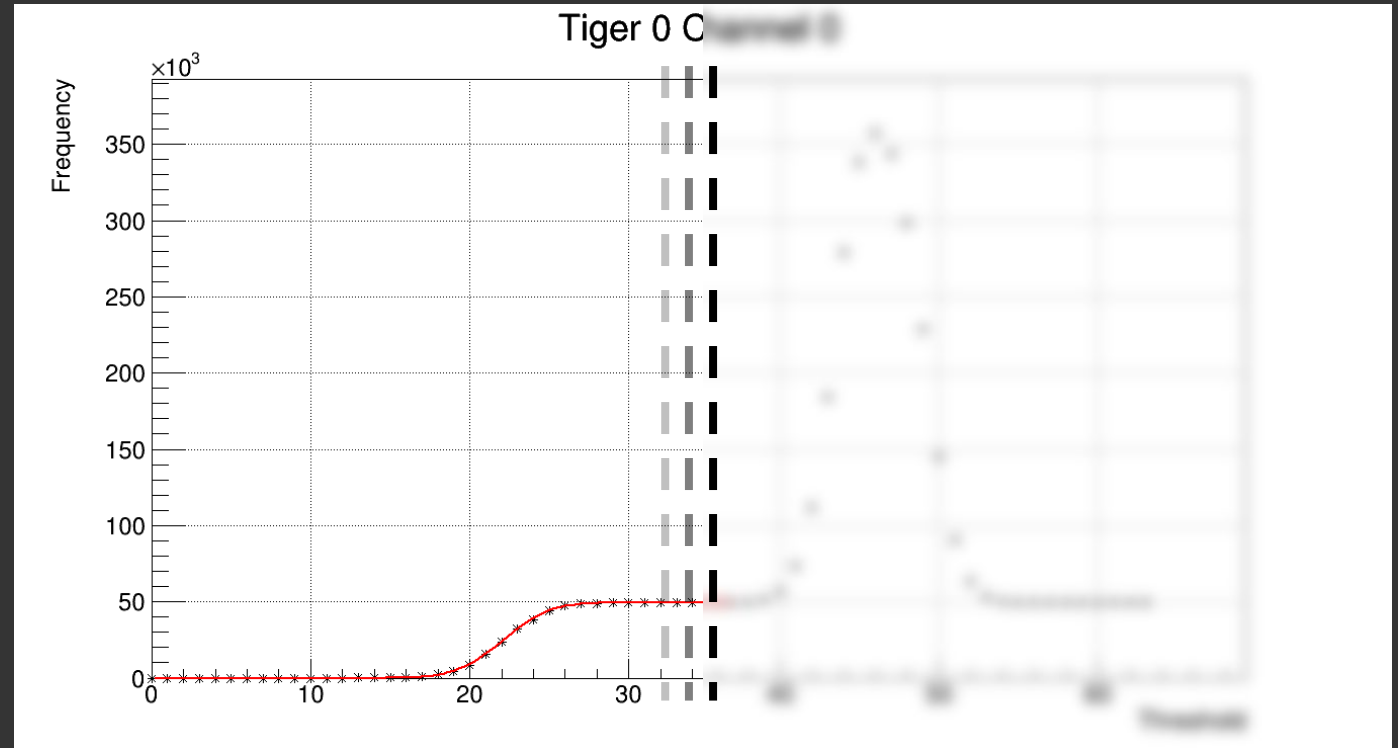
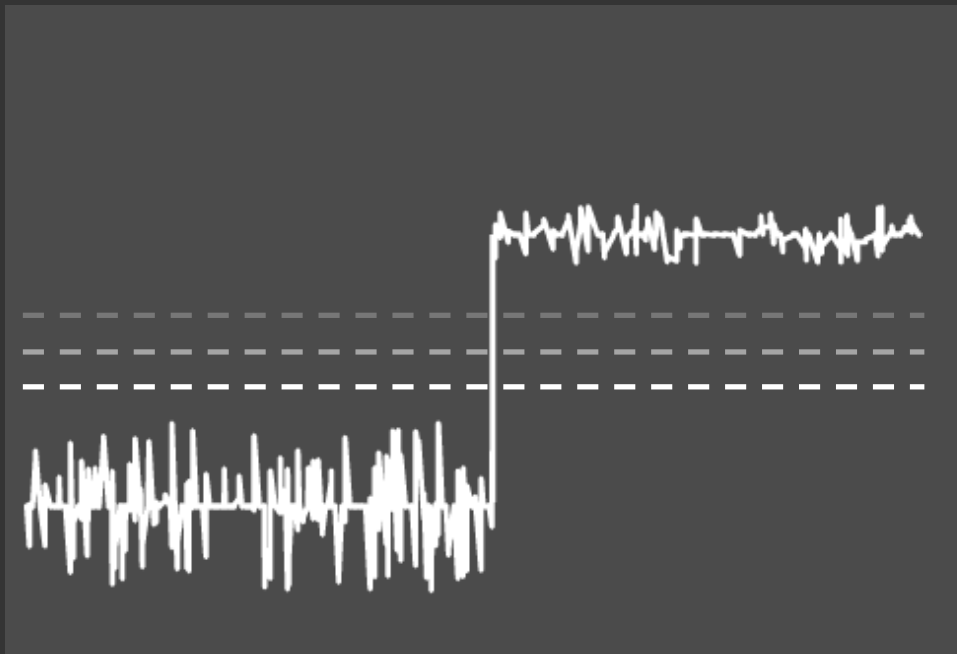

The number of threshold crossings in 1/10 of a second is registered

# Threshold Scan

Each threshold step is 0.5 fC

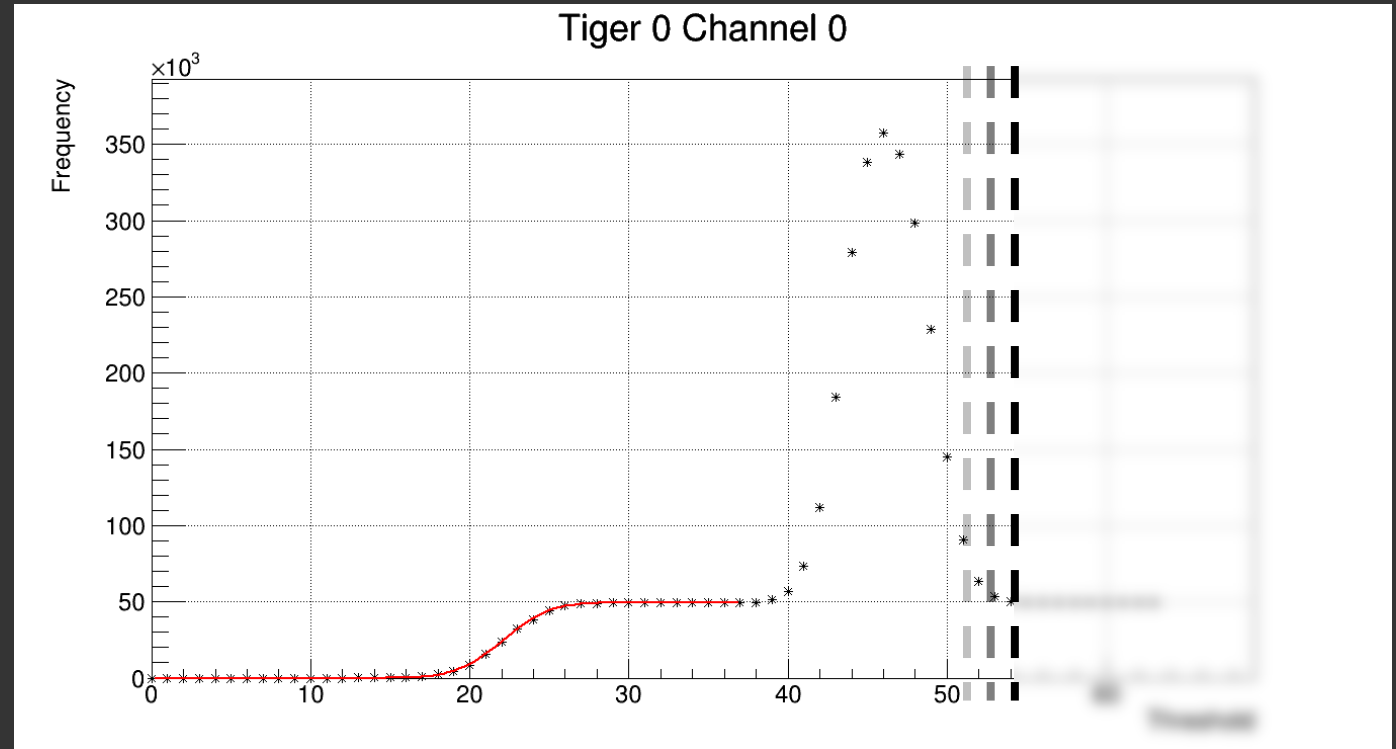
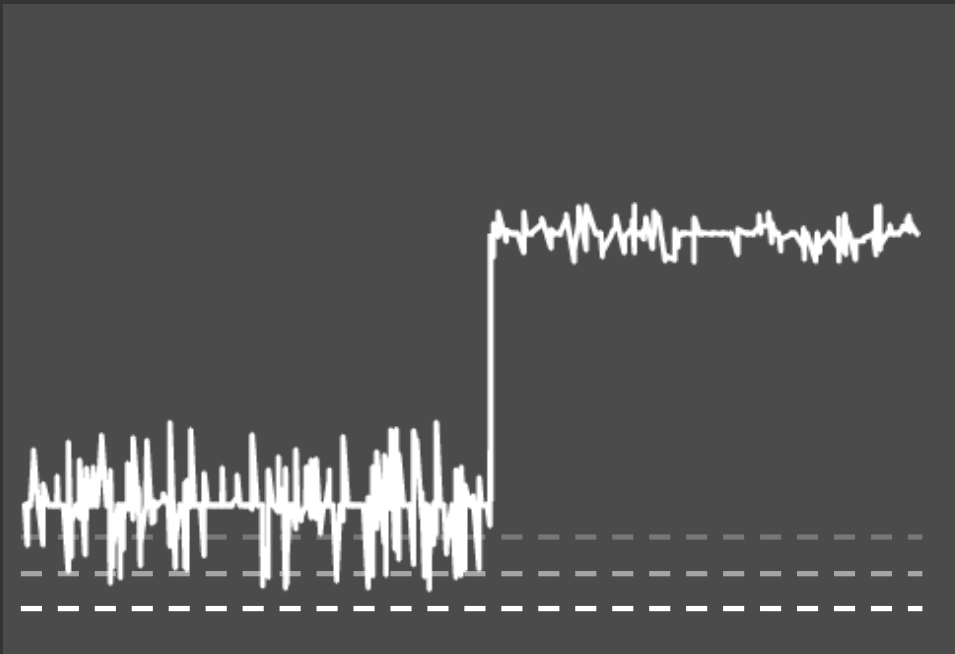

The number of threshold crossings  
in 1/10 of a second is registered

# Threshold Scan

Each threshold step is 0.5 fC

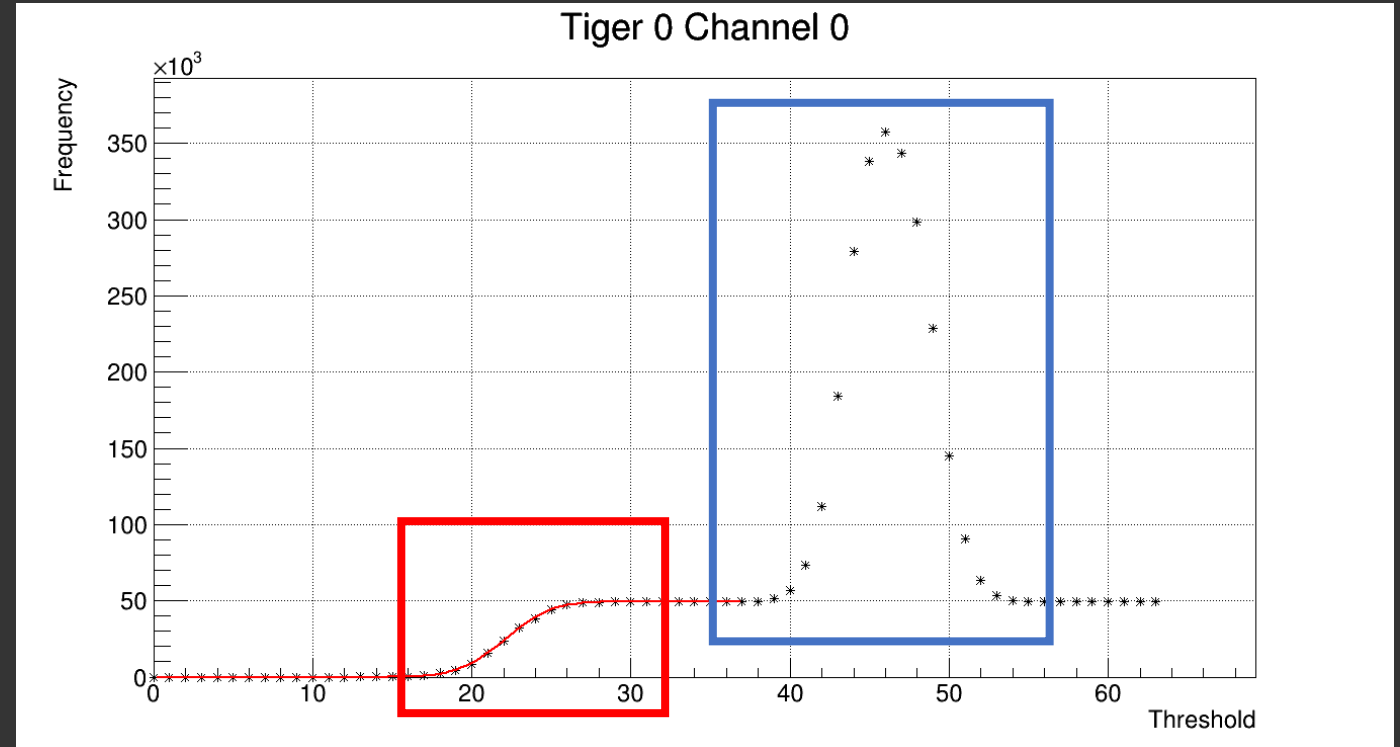
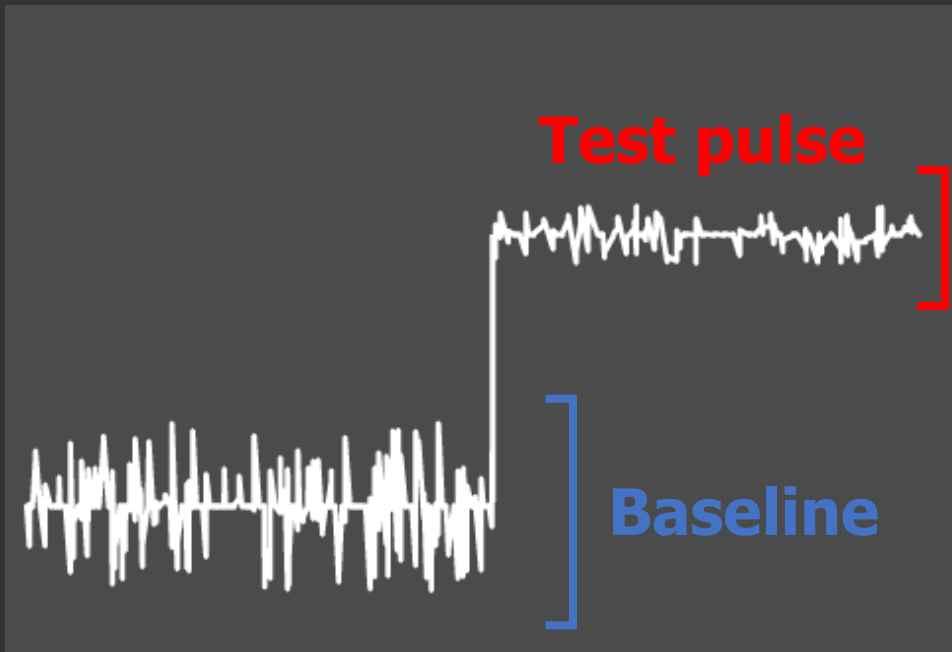

The number of threshold crossings in 1/10 of a second is registered

# Noise Level distribution

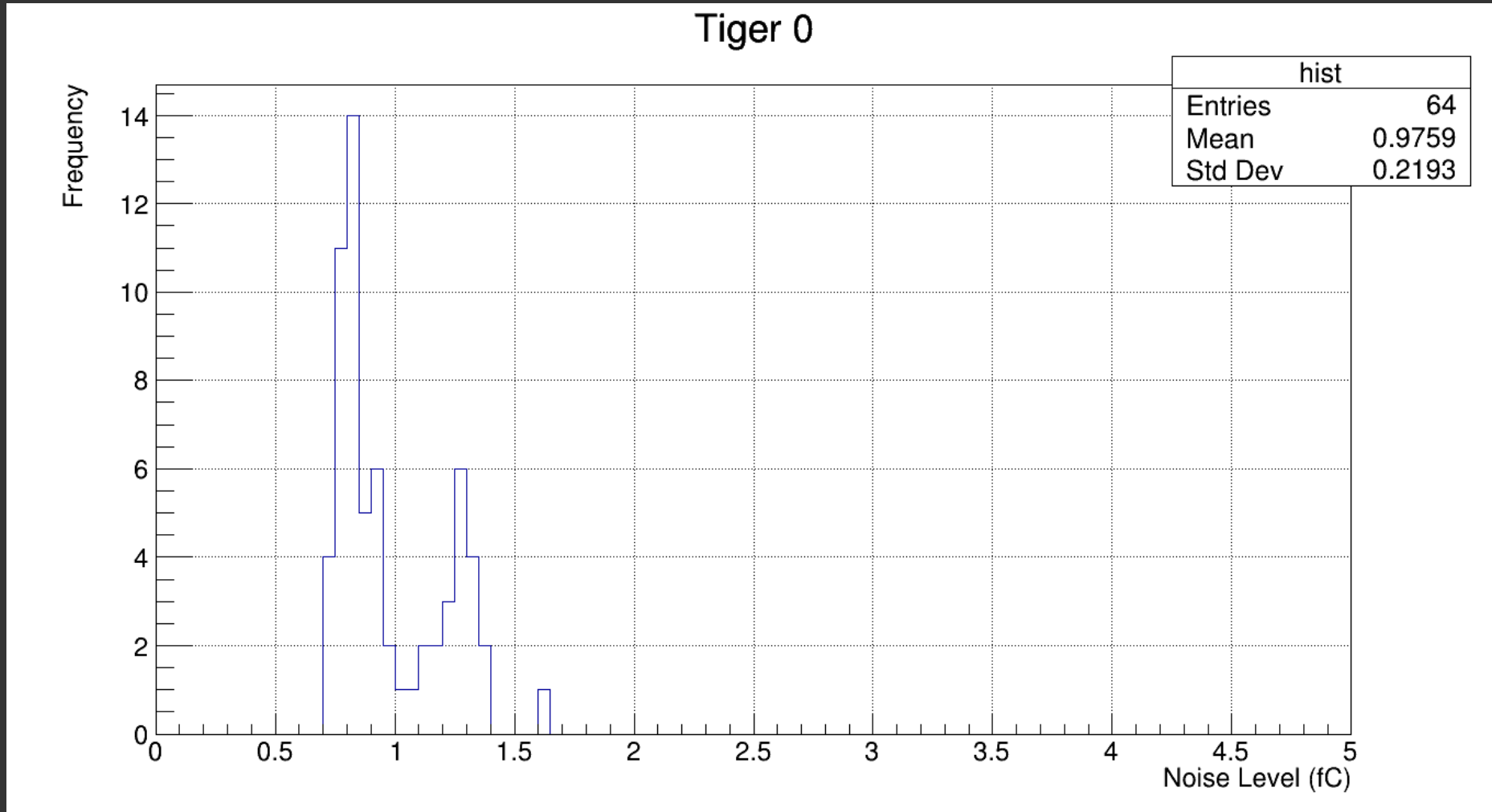

# T and E Branches

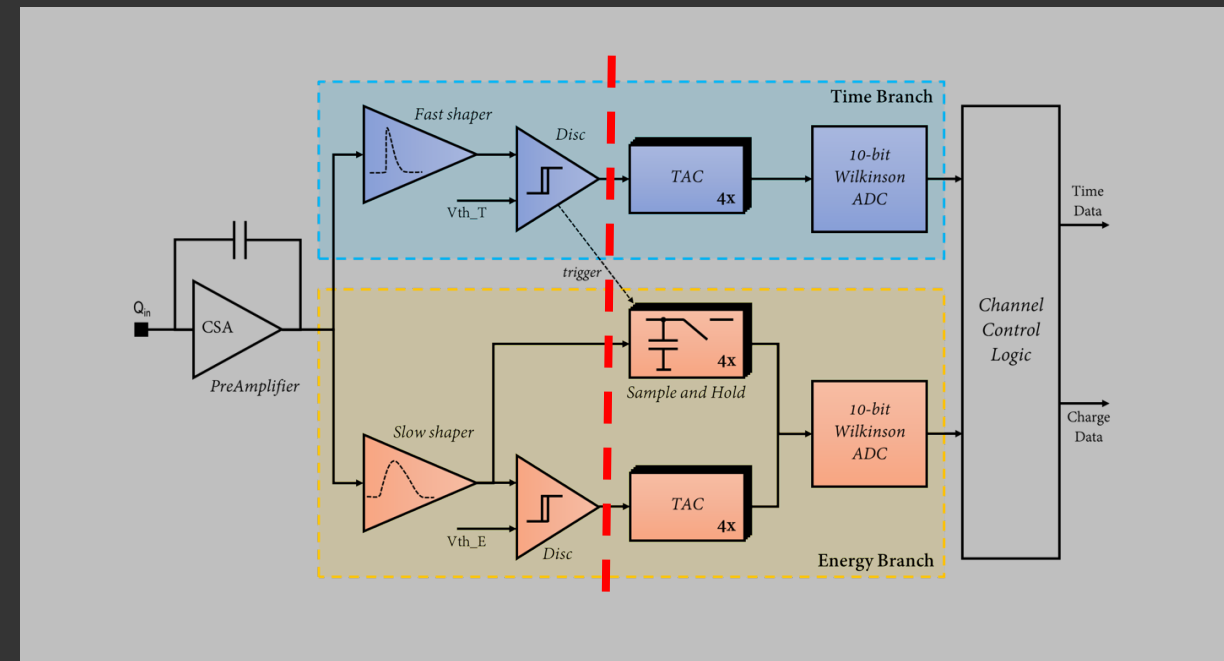
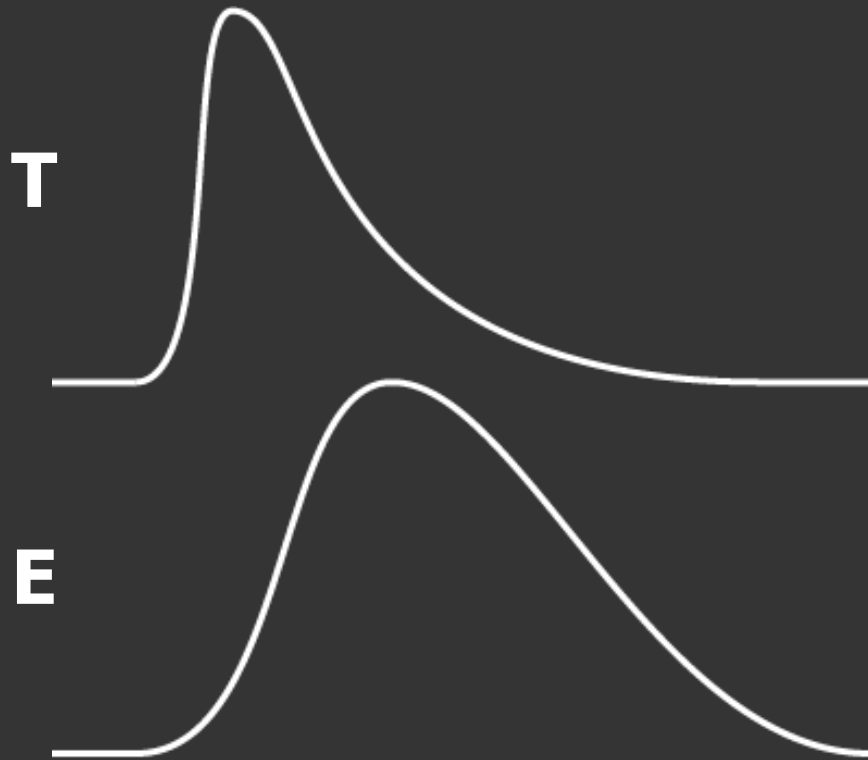

**T Shaper -> Faster rise and fall**

**E Shaper -> Slower rise and fall**

# External Factors

The temperature of each chip is logged before and after each scan

Beam Parameters are made available through the online monitor

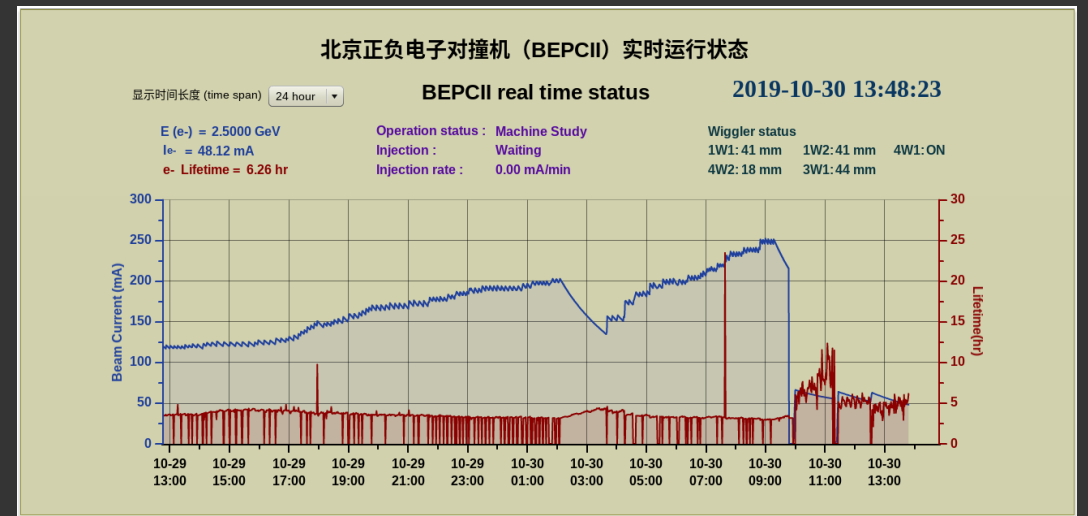
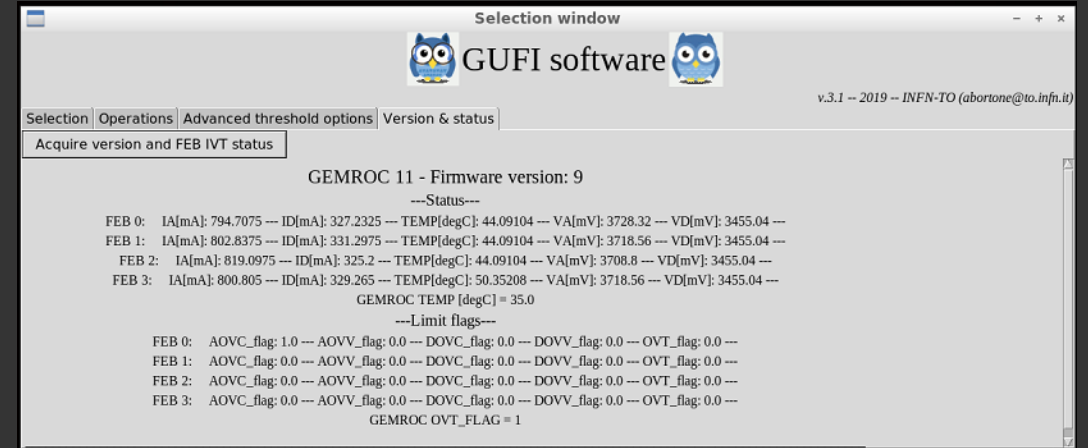





# Data and operations

t\_branch

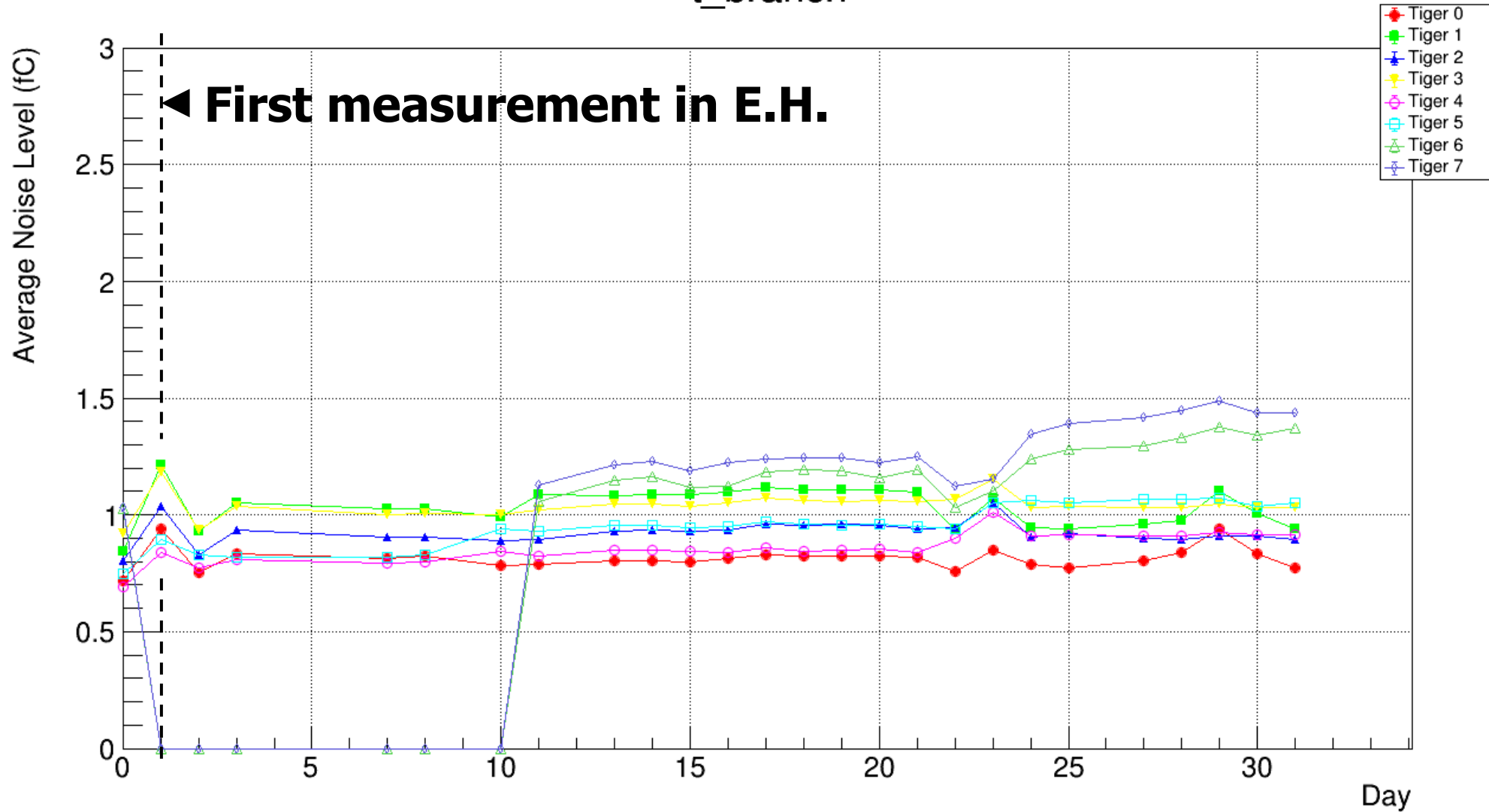

# e\_branch

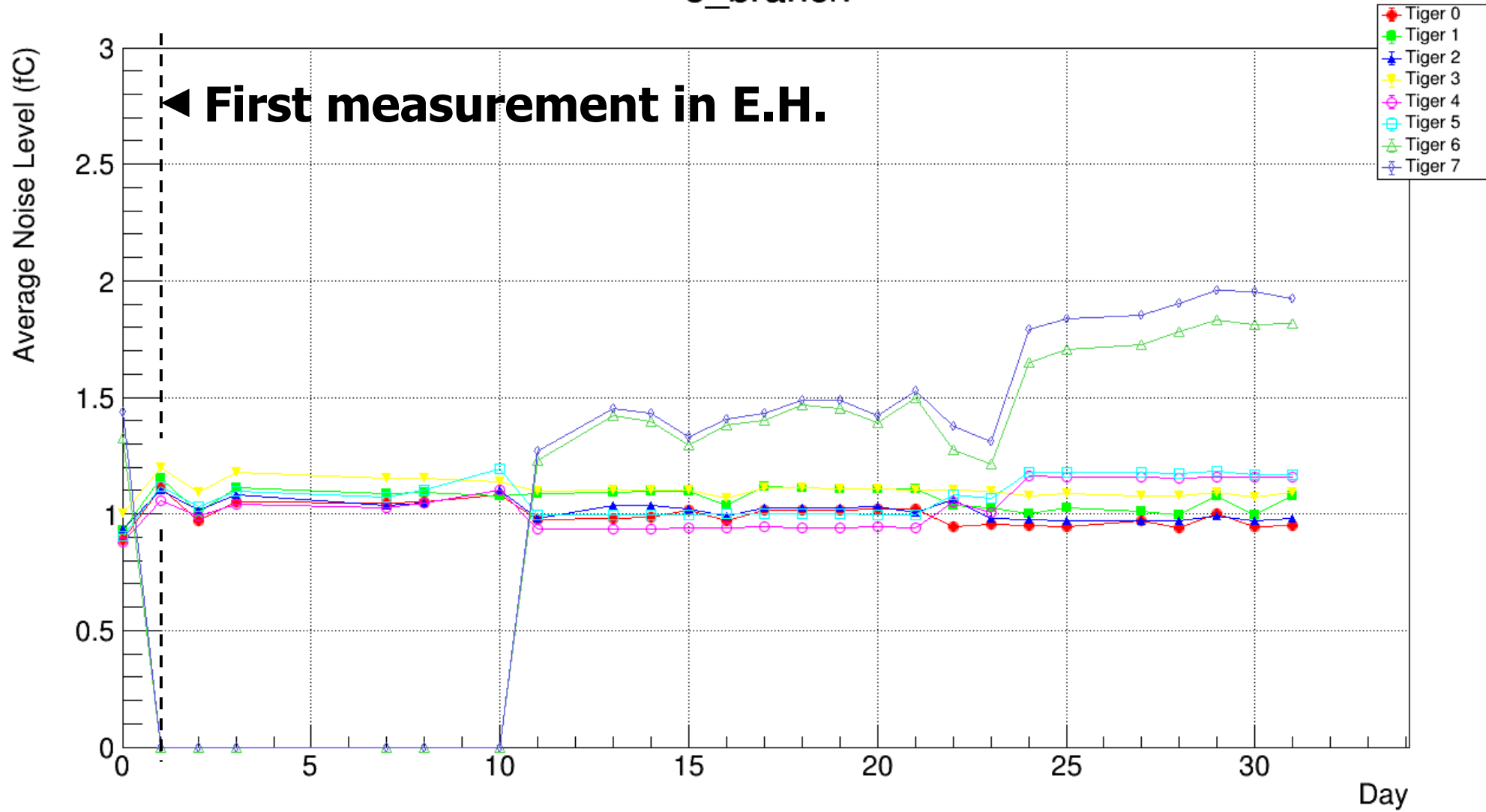

# Regrounding Operations

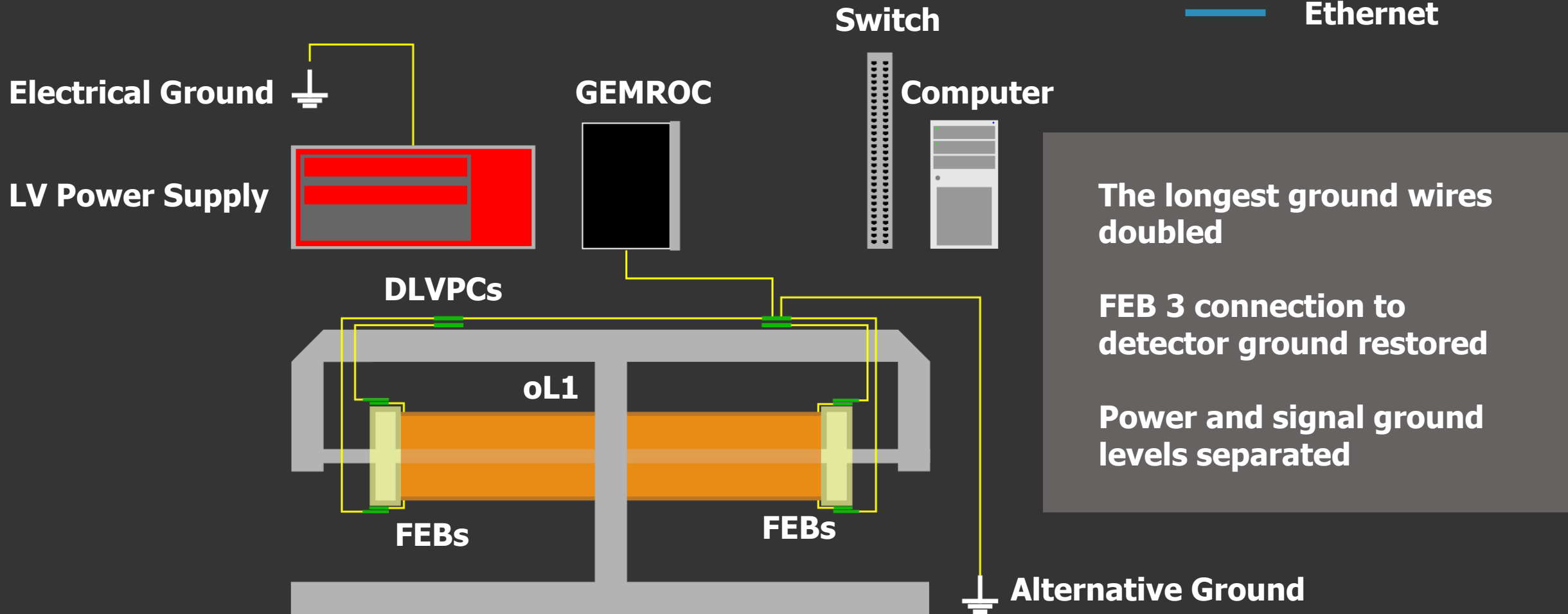

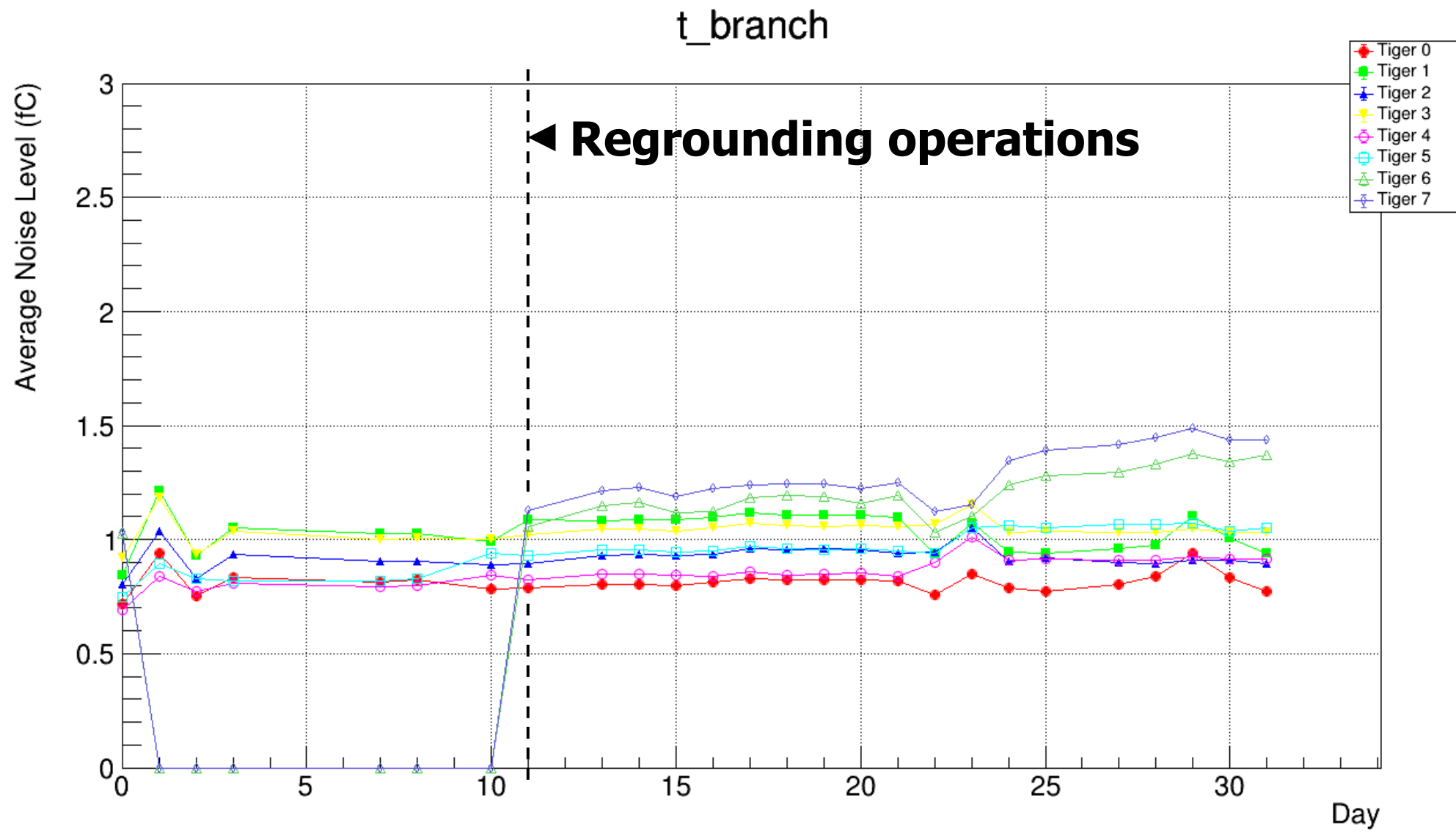

# e\_branch

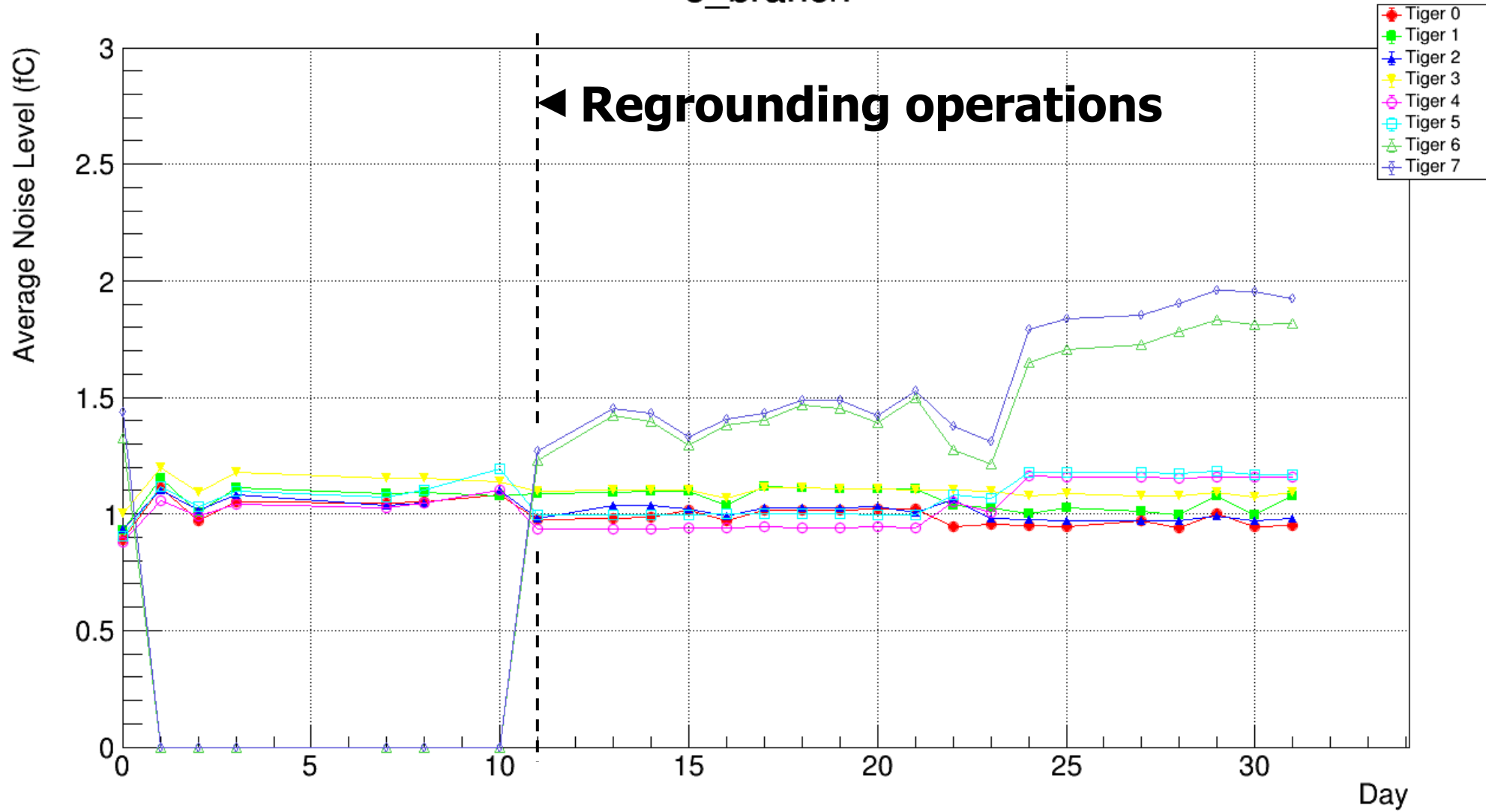

# Shielding Operations

Faraday cage built from a repurposed L2 Cathode

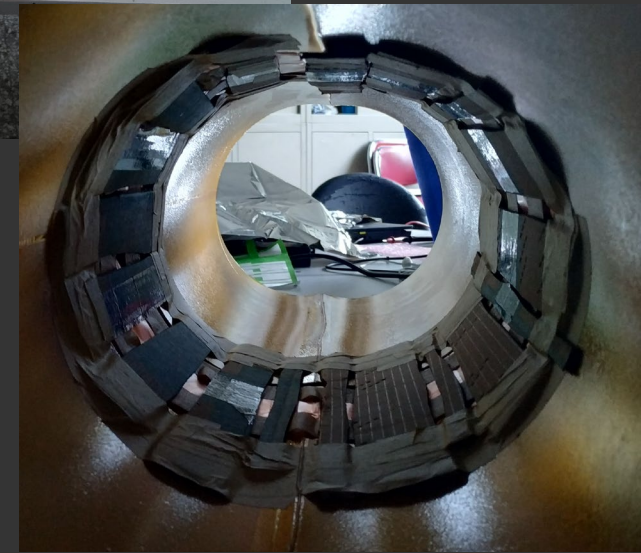
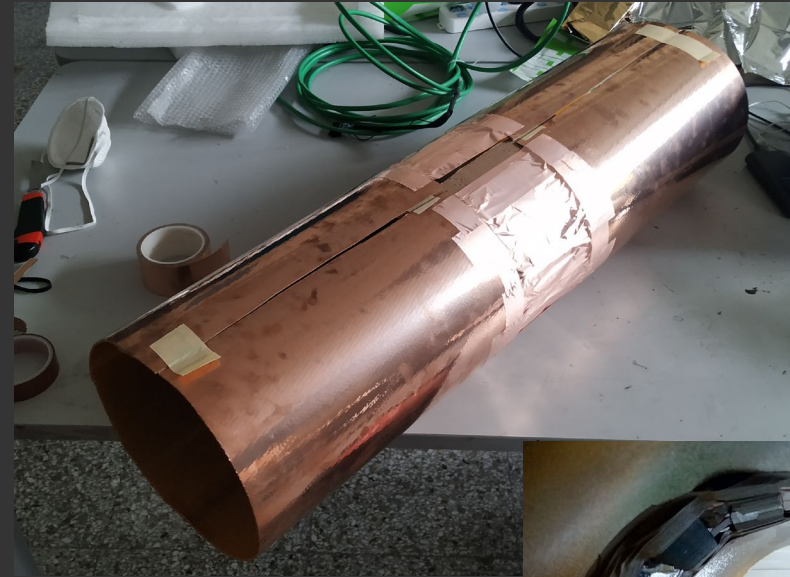

Cable Shielding Scheme



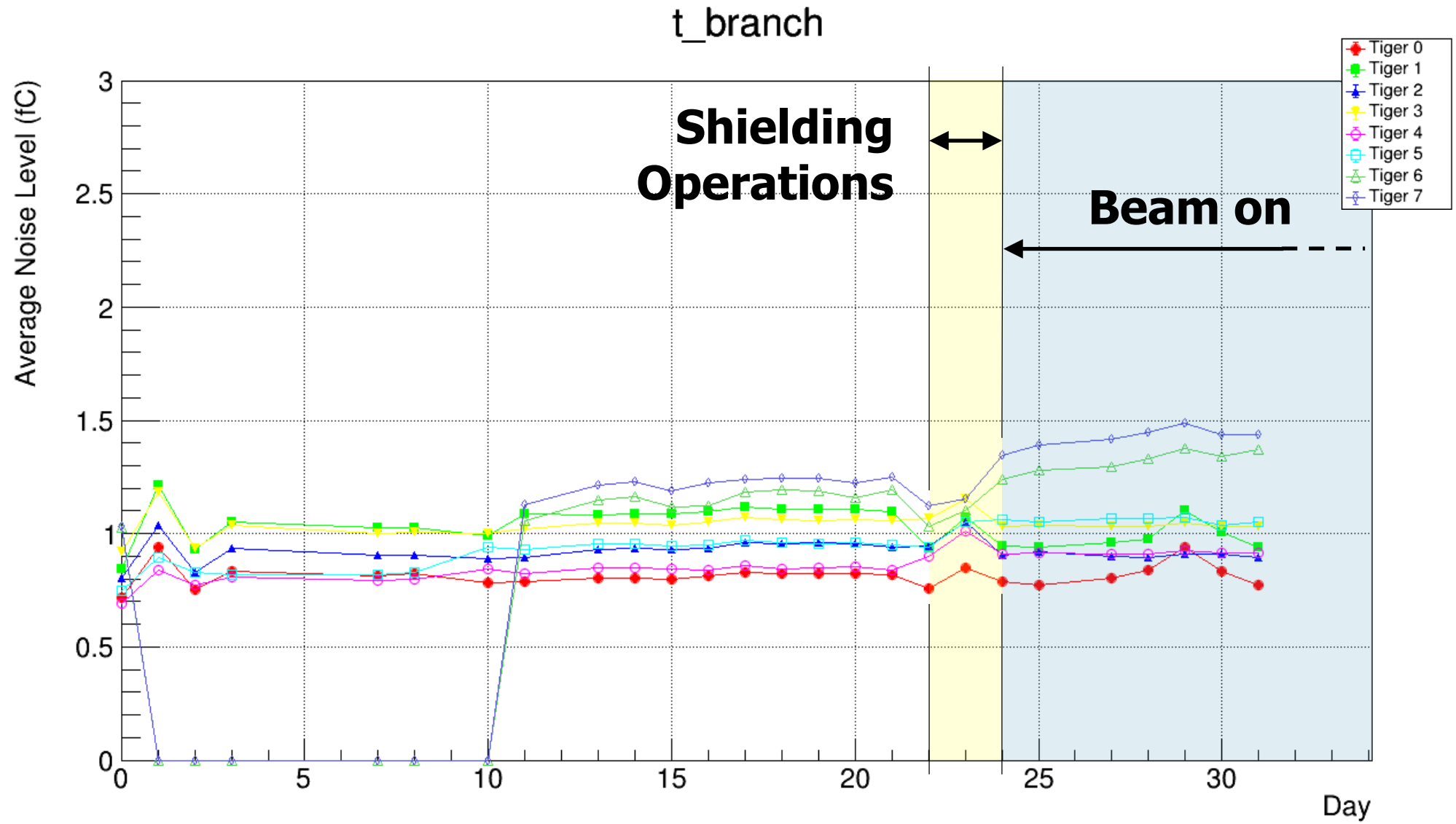



# e\_branch

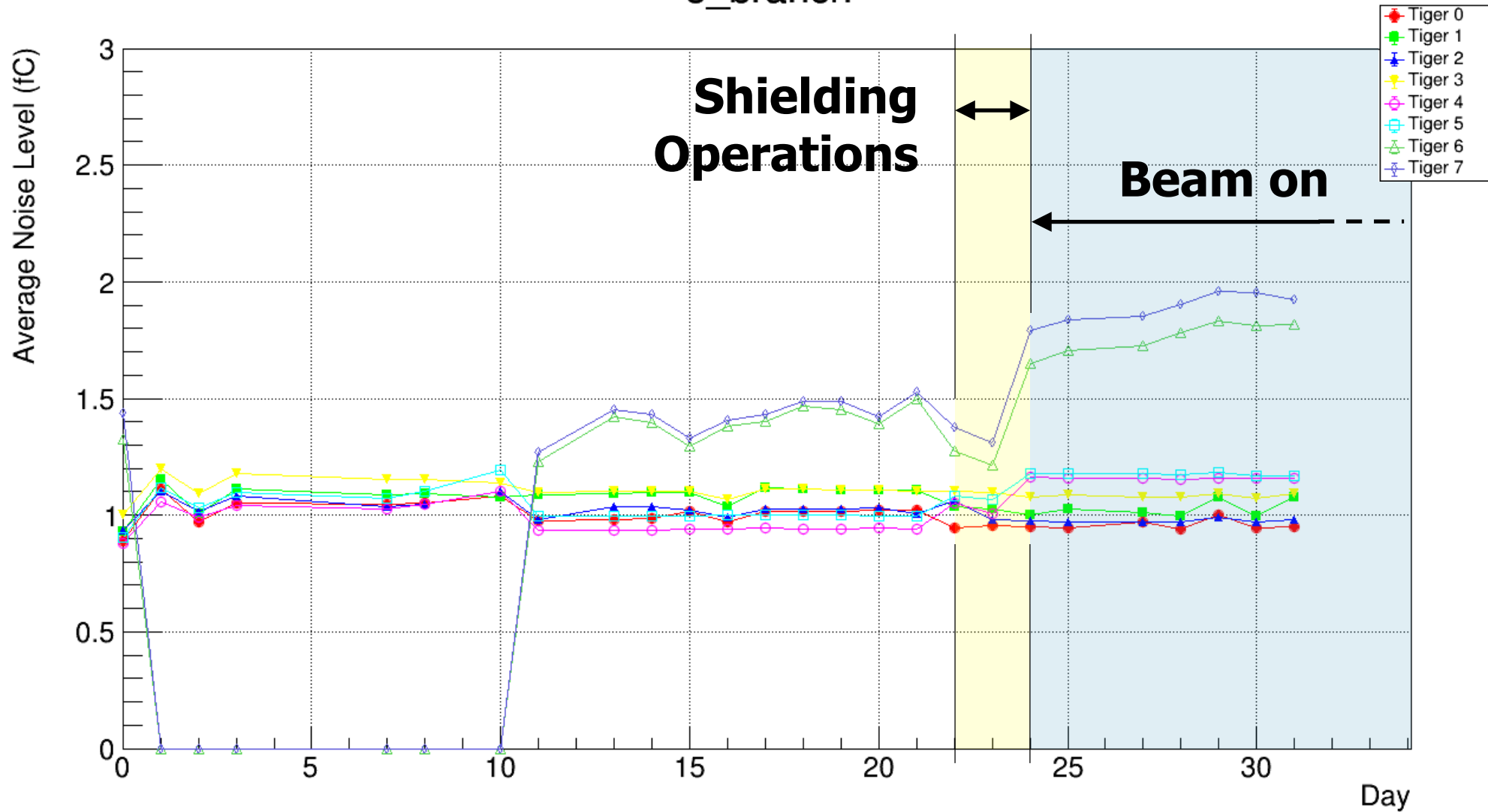

# Beam Stability Issues



**24-25 Oct**

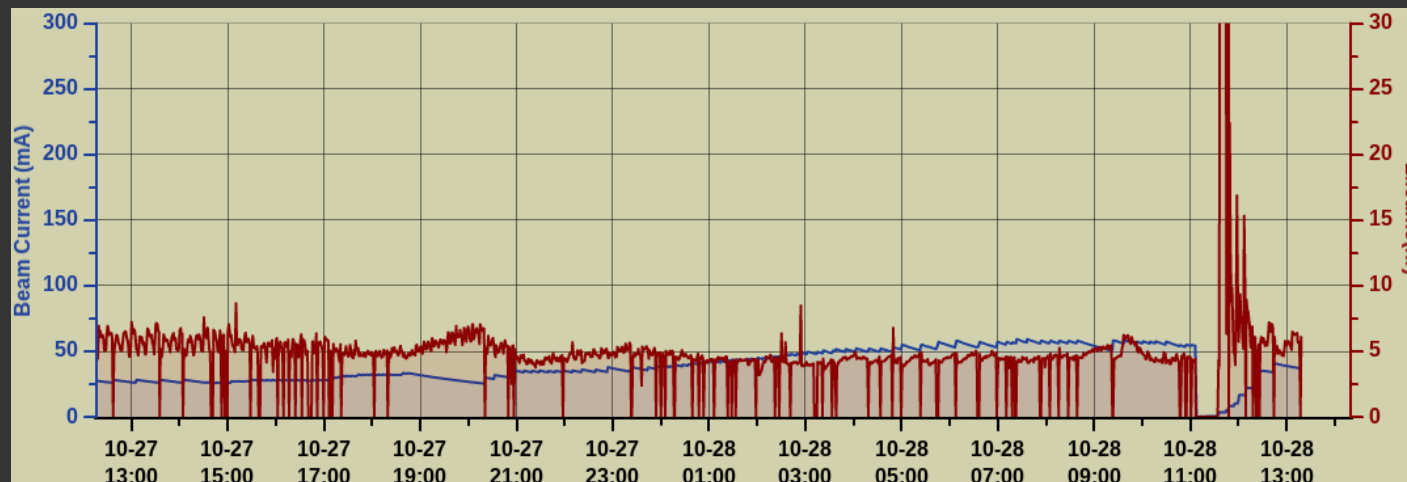

**27-28 Oct**



# Conclusion

# Summary and roadmap

**ONGOING**      **Synchrotron radiation phase**  
Study of the machine and beam contributions

**ON HOLD**      **Shutdown phase**  
Zero point acquisitions  
Study of alternative grounding and shielding configurations

**TO DO**      **BESIII data taking Phase**  
Study of the detector's contribution

# Outlook

**The setup can work as a test bench to try new grounding solutions**

**Any input is welcome!**

**The setup is available for anyone willing to try out new ideas**

*Thanks for your attention*

# Backup Slides

# tgr\_0\_t\_branch

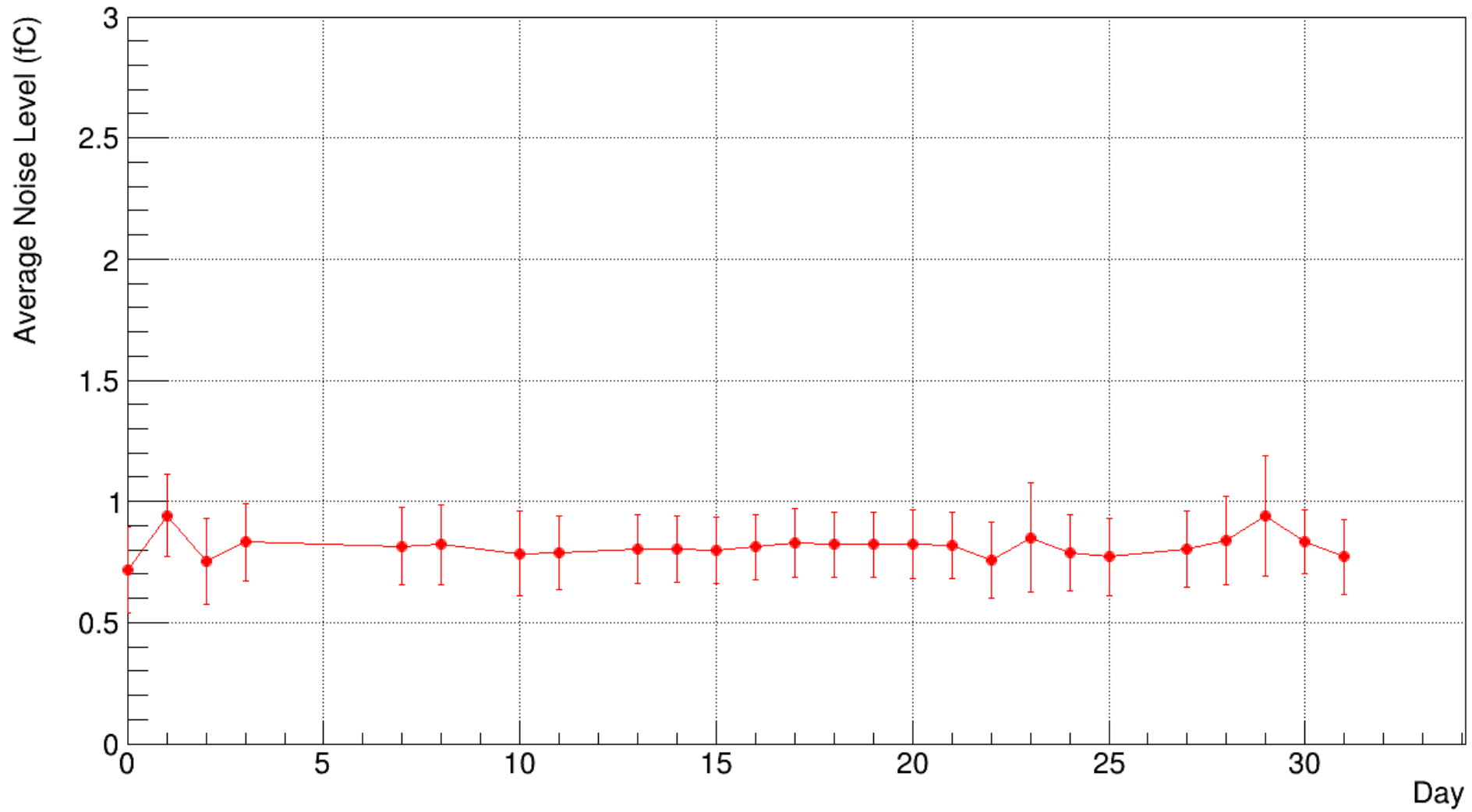



# tgr\_0\_e\_branch

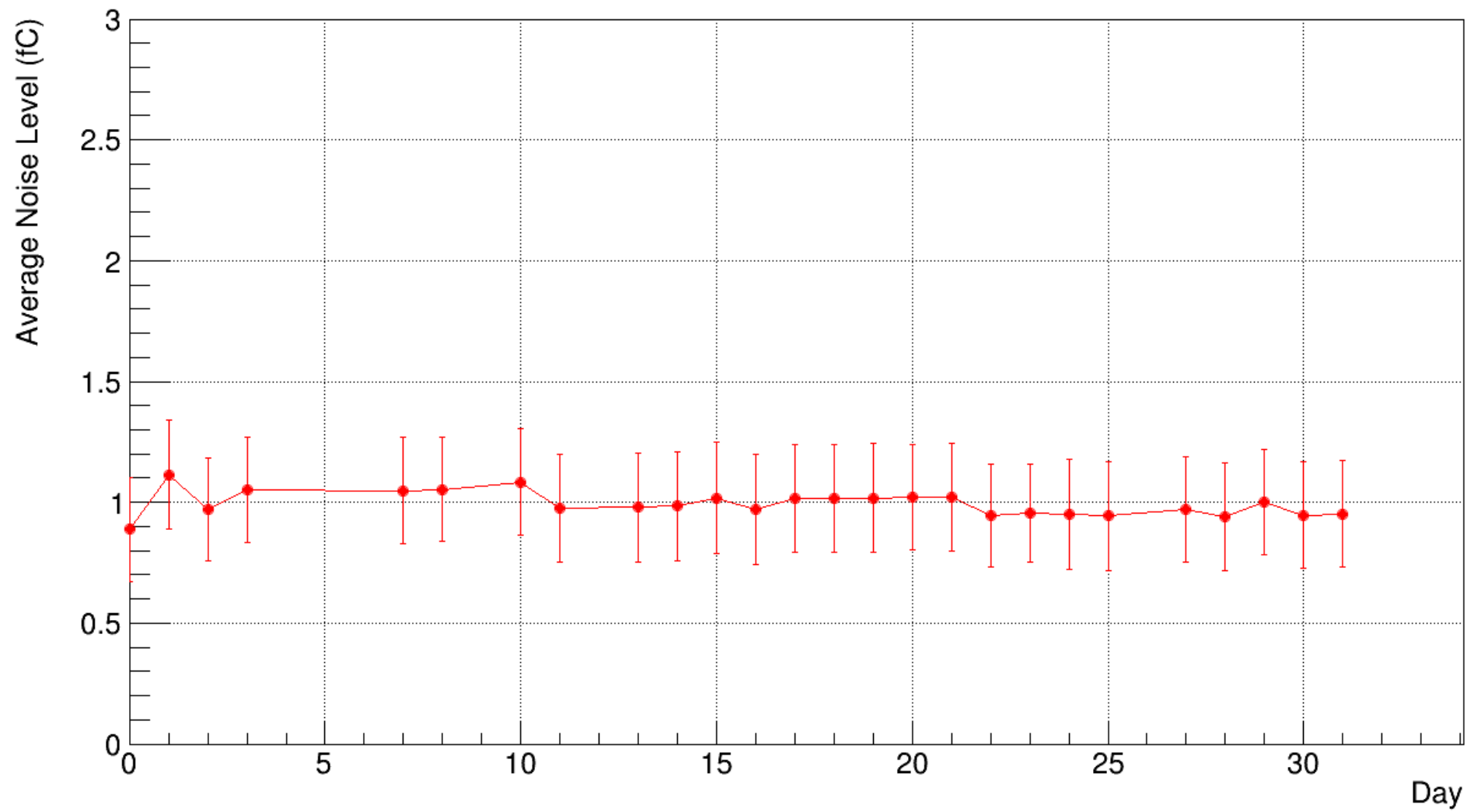

# tgr\_1\_e\_branch

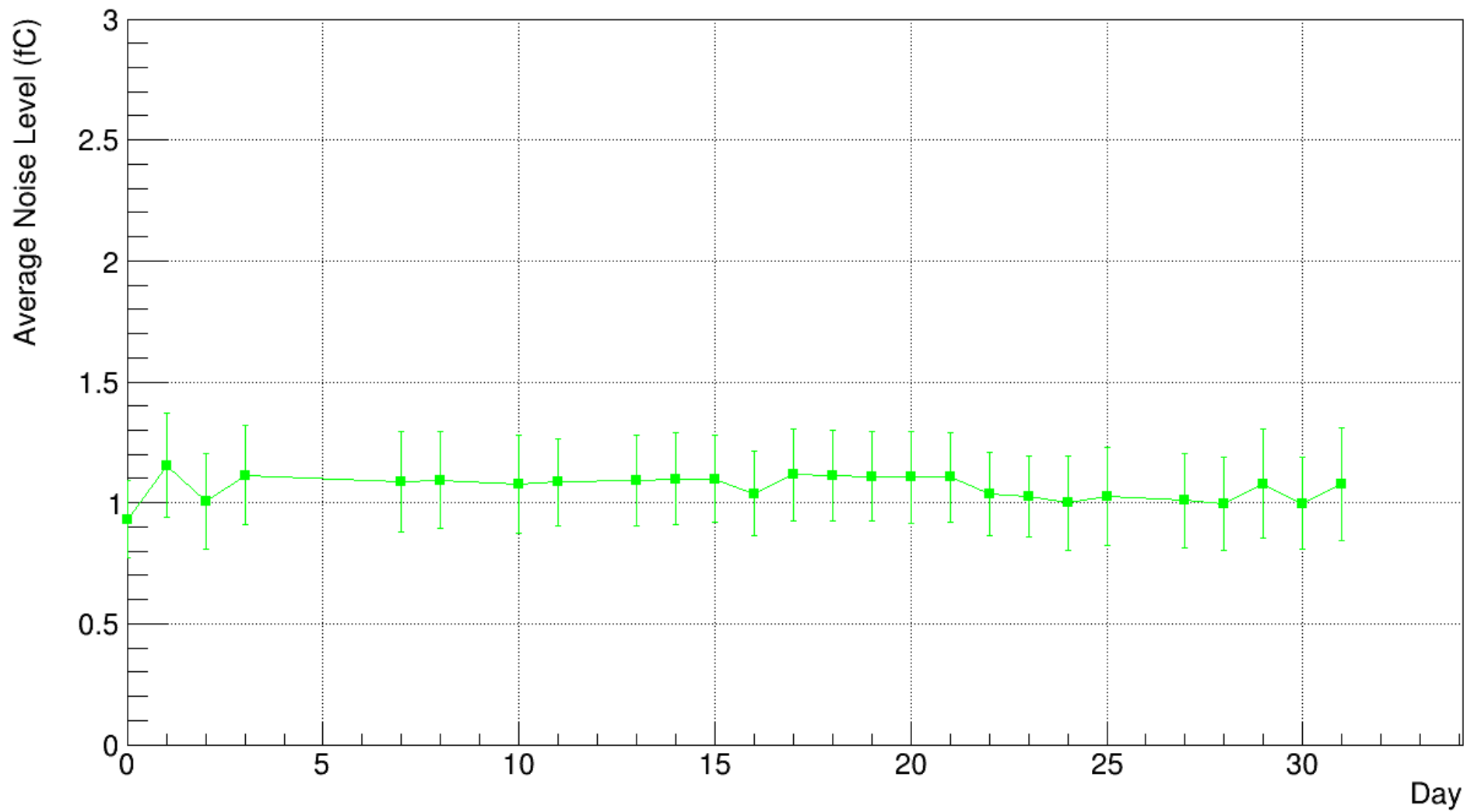

# tgr\_1\_t\_branch

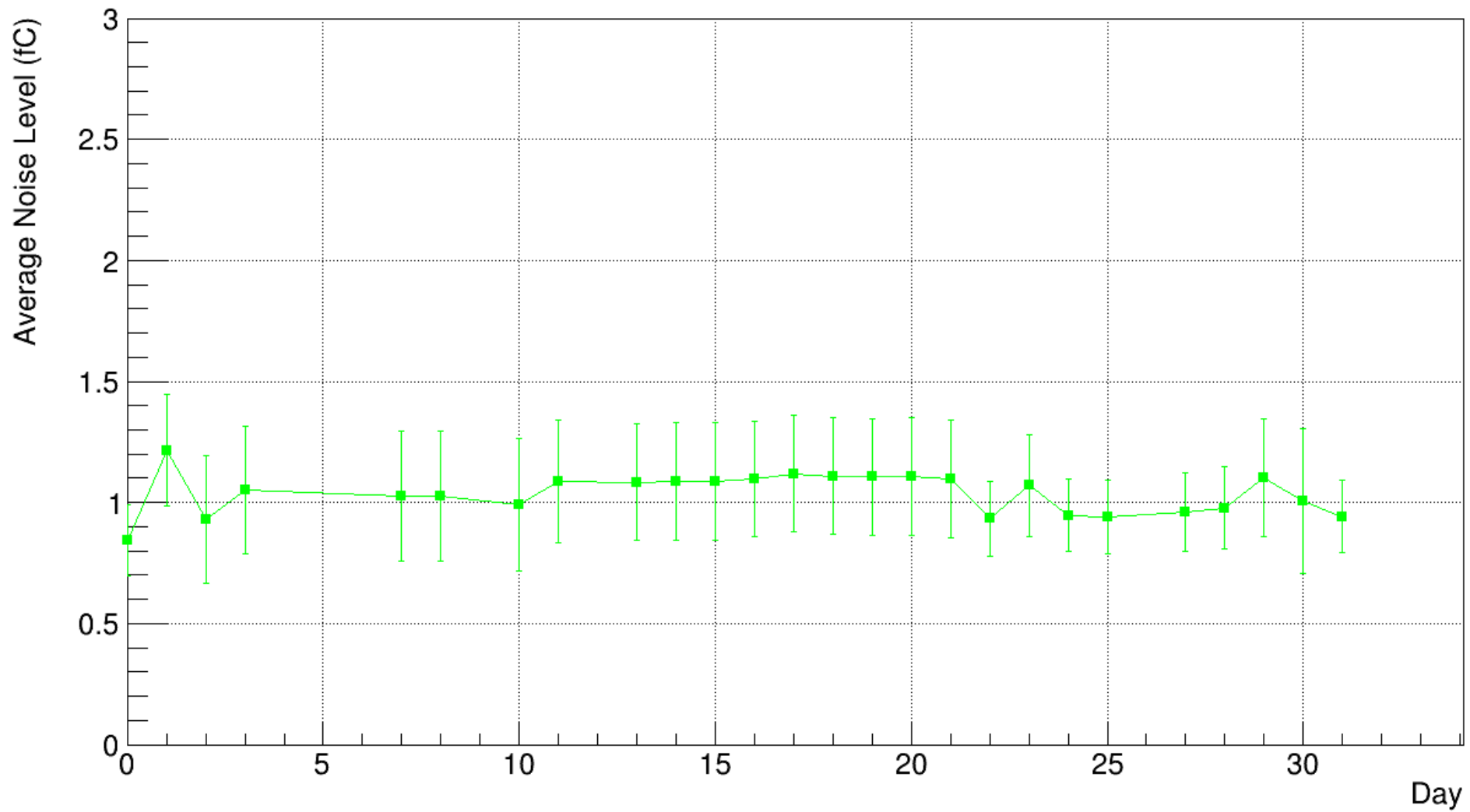

# tgr\_2\_e\_branch

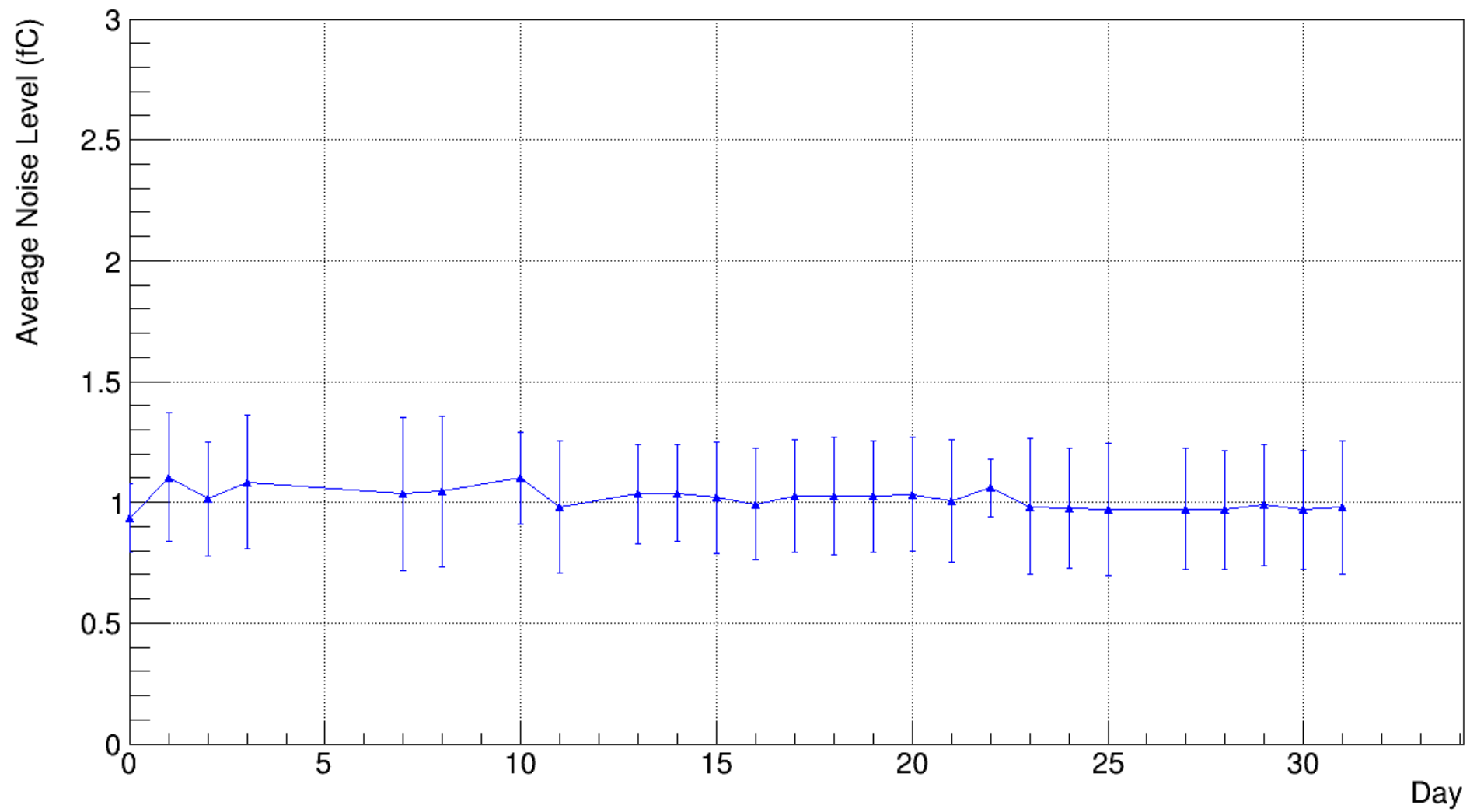

# tgr\_2\_t\_branch

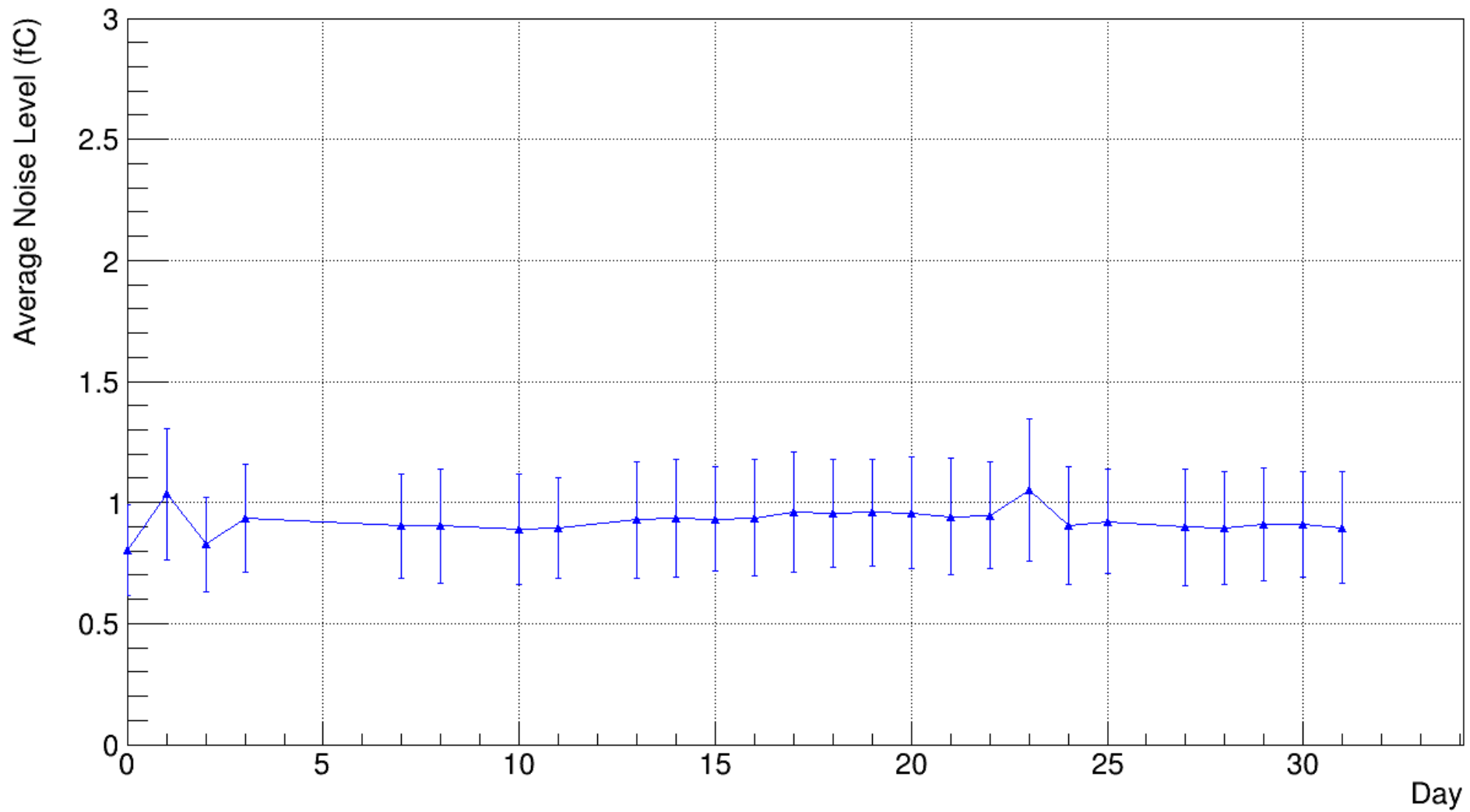

# tgr\_3\_e\_branch

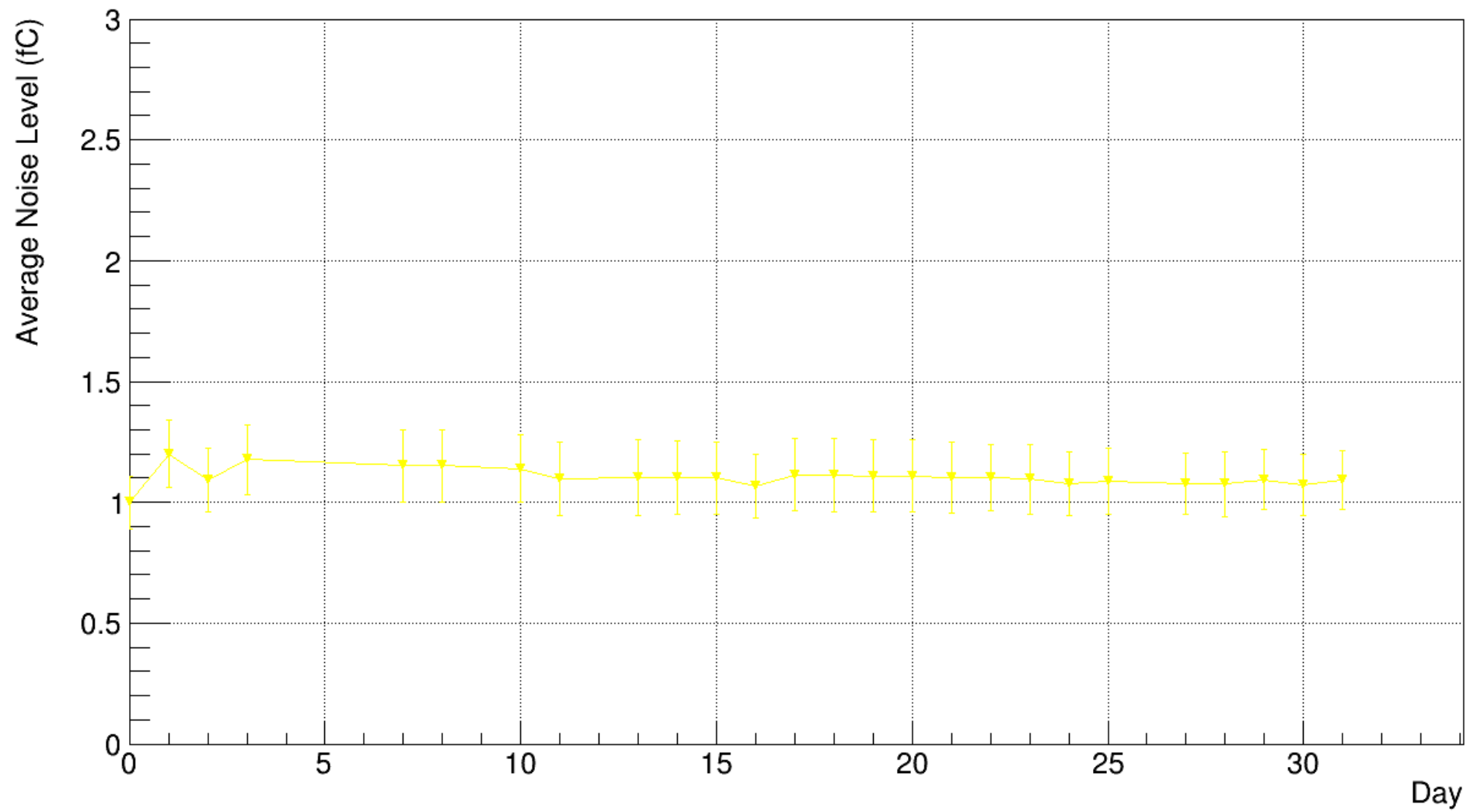

# tgr\_3\_t\_branch

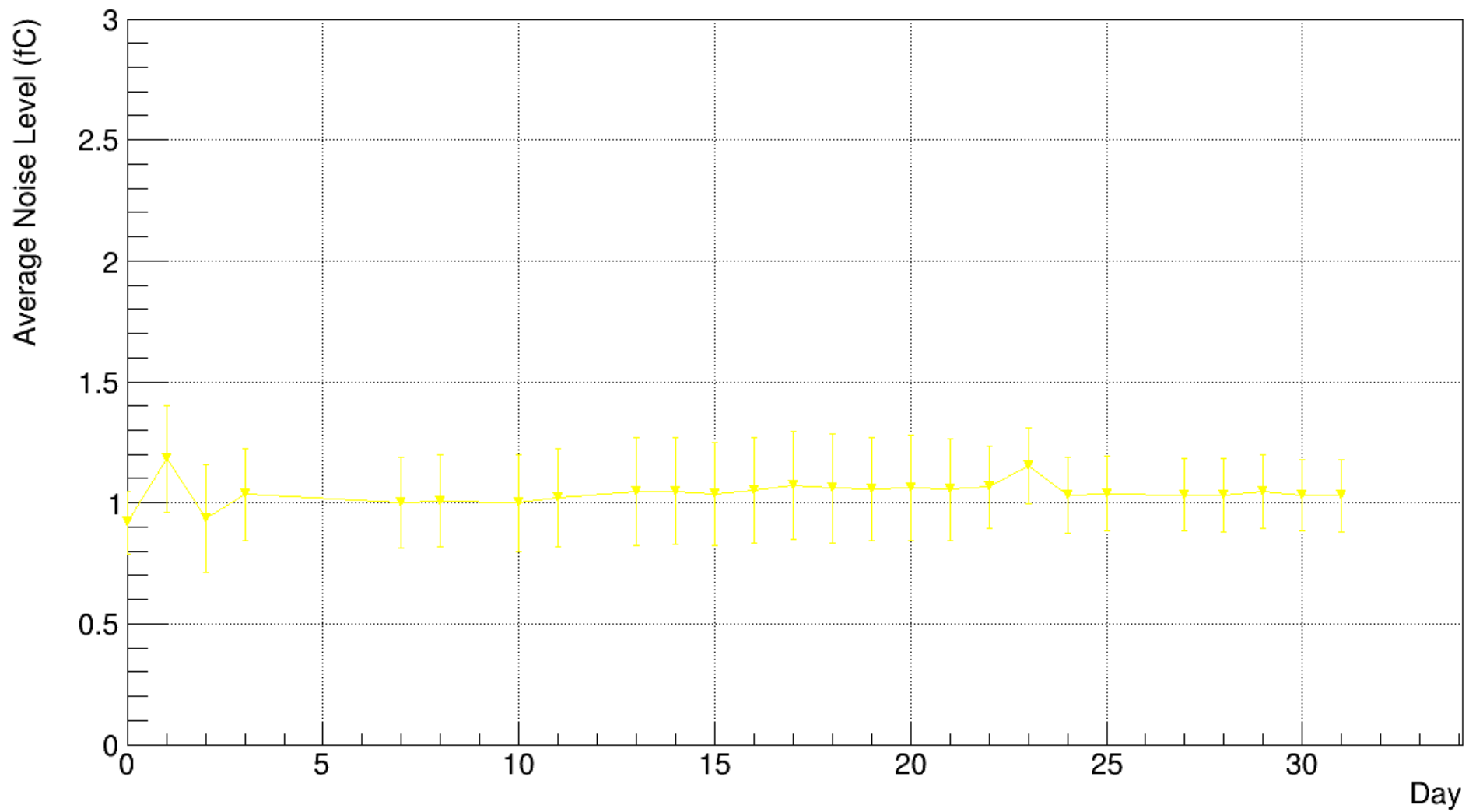

# tgr\_4\_e\_branch

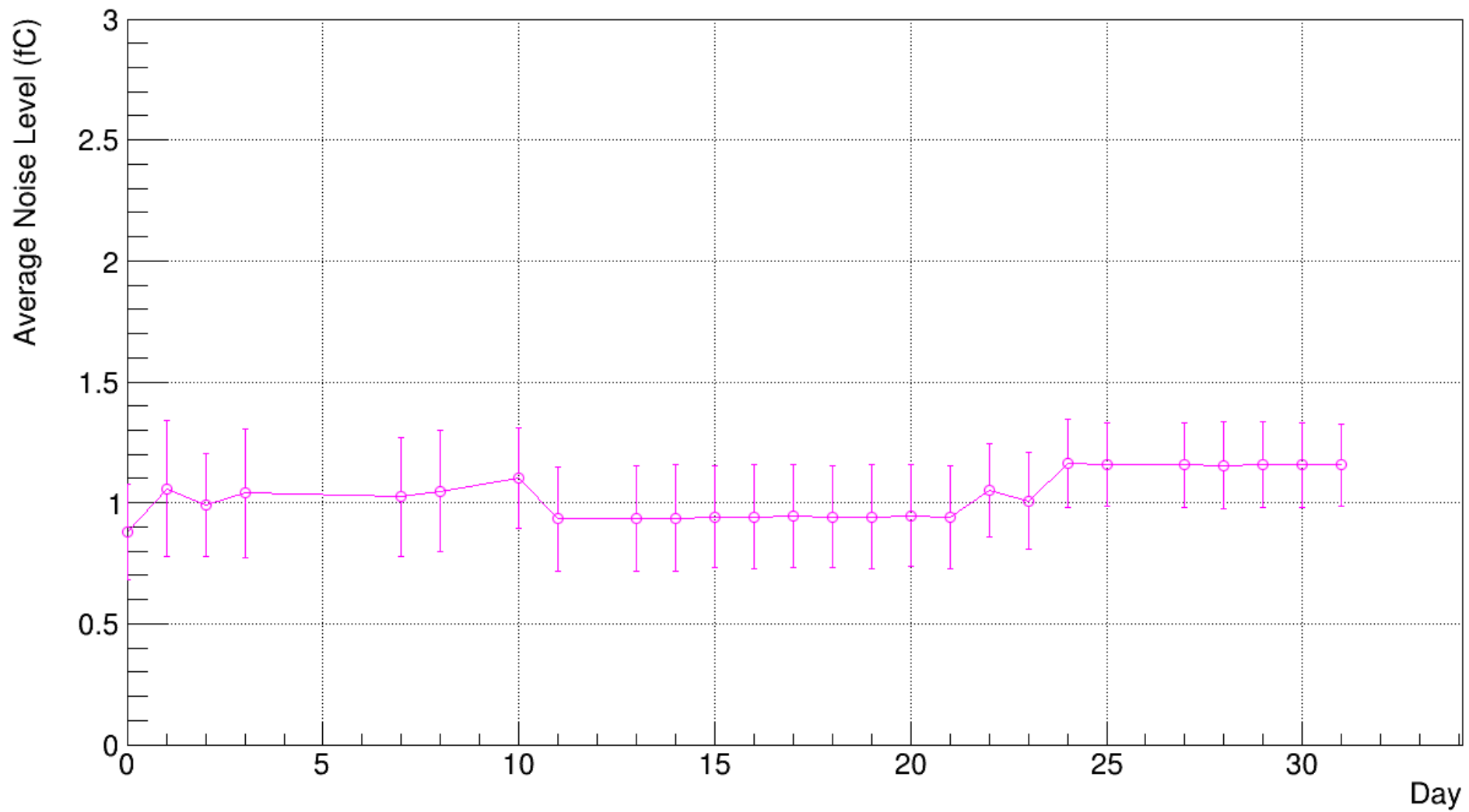



# tgr\_4\_t\_branch

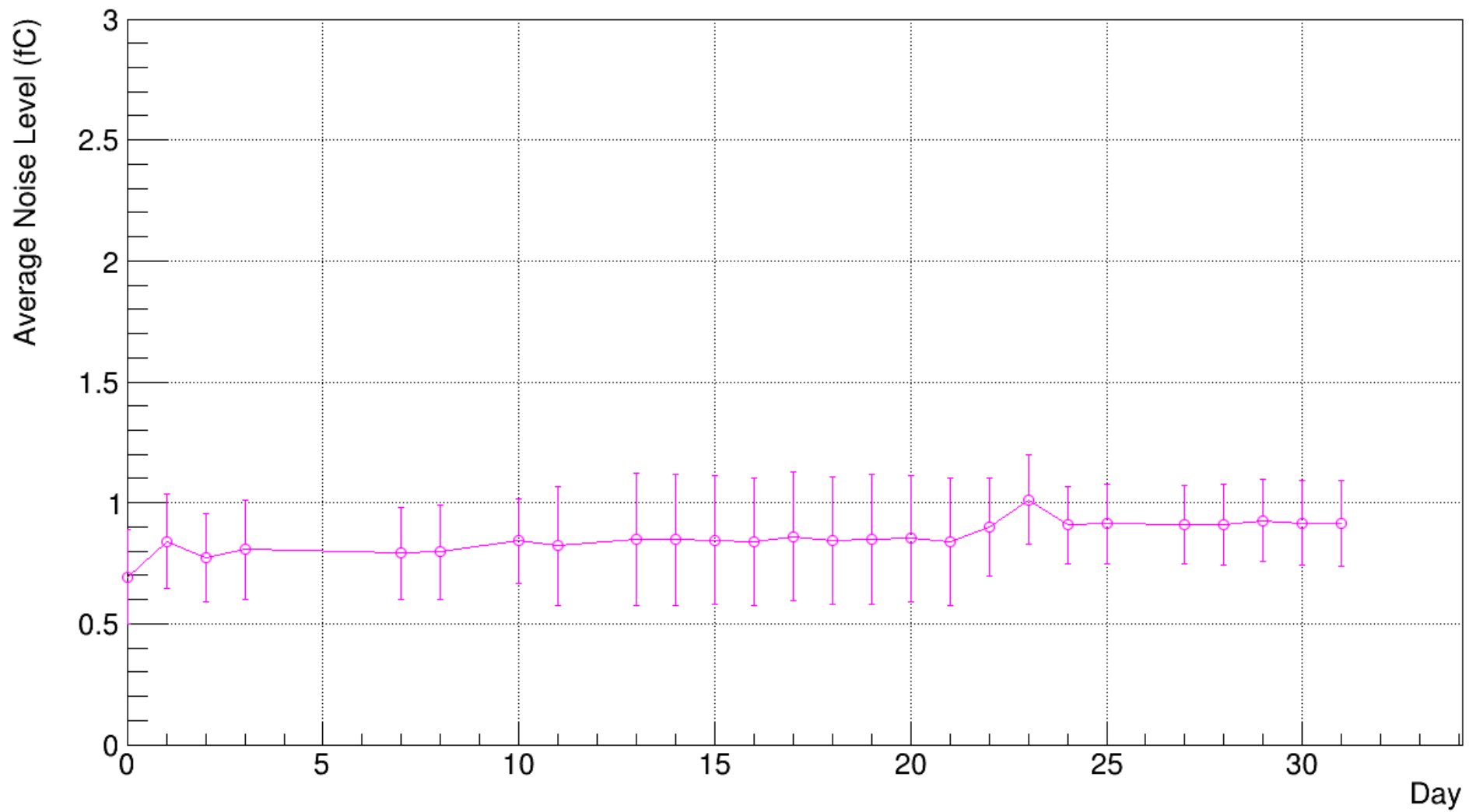

# tgr\_5\_e\_branch

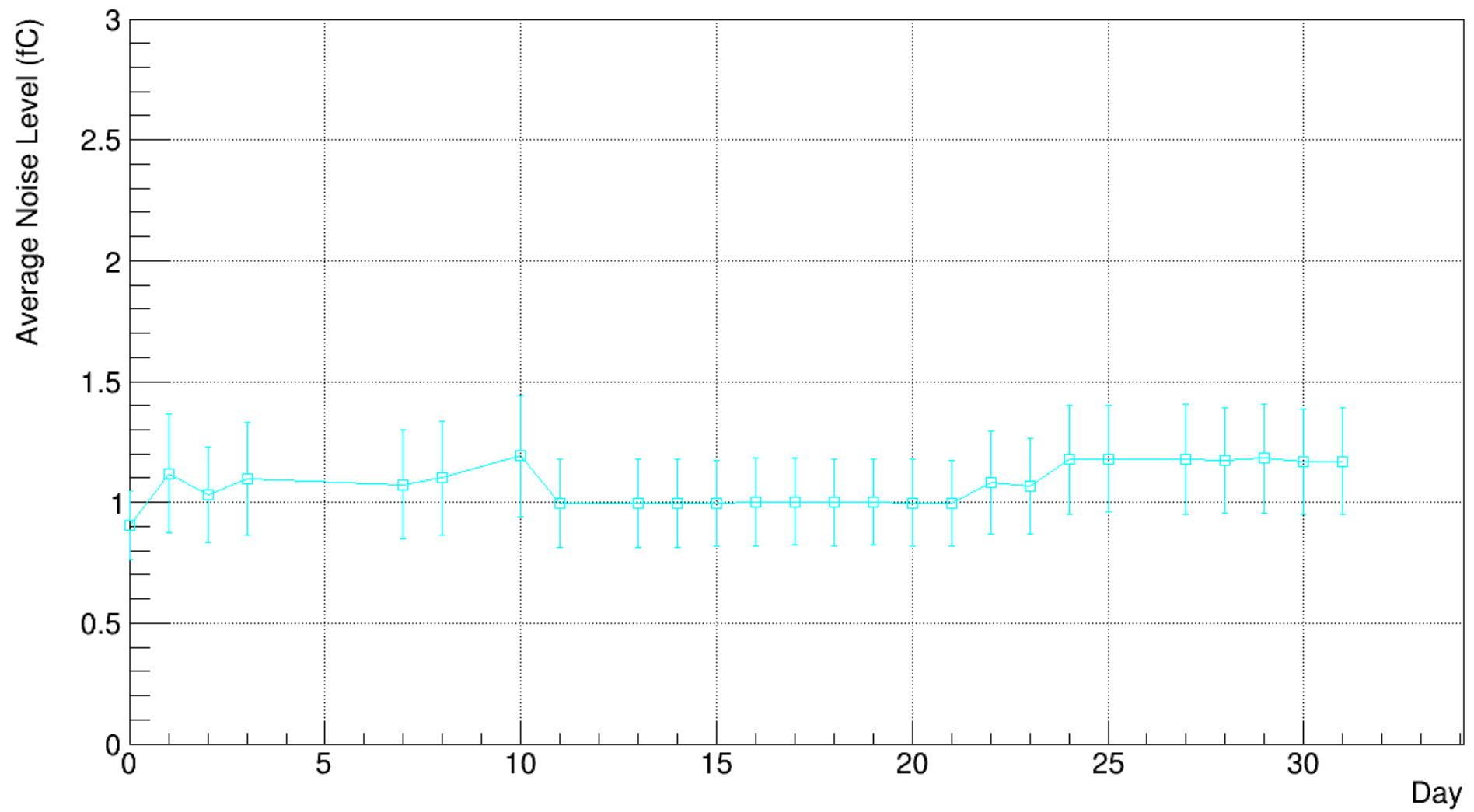

# tgr\_5\_t\_branch

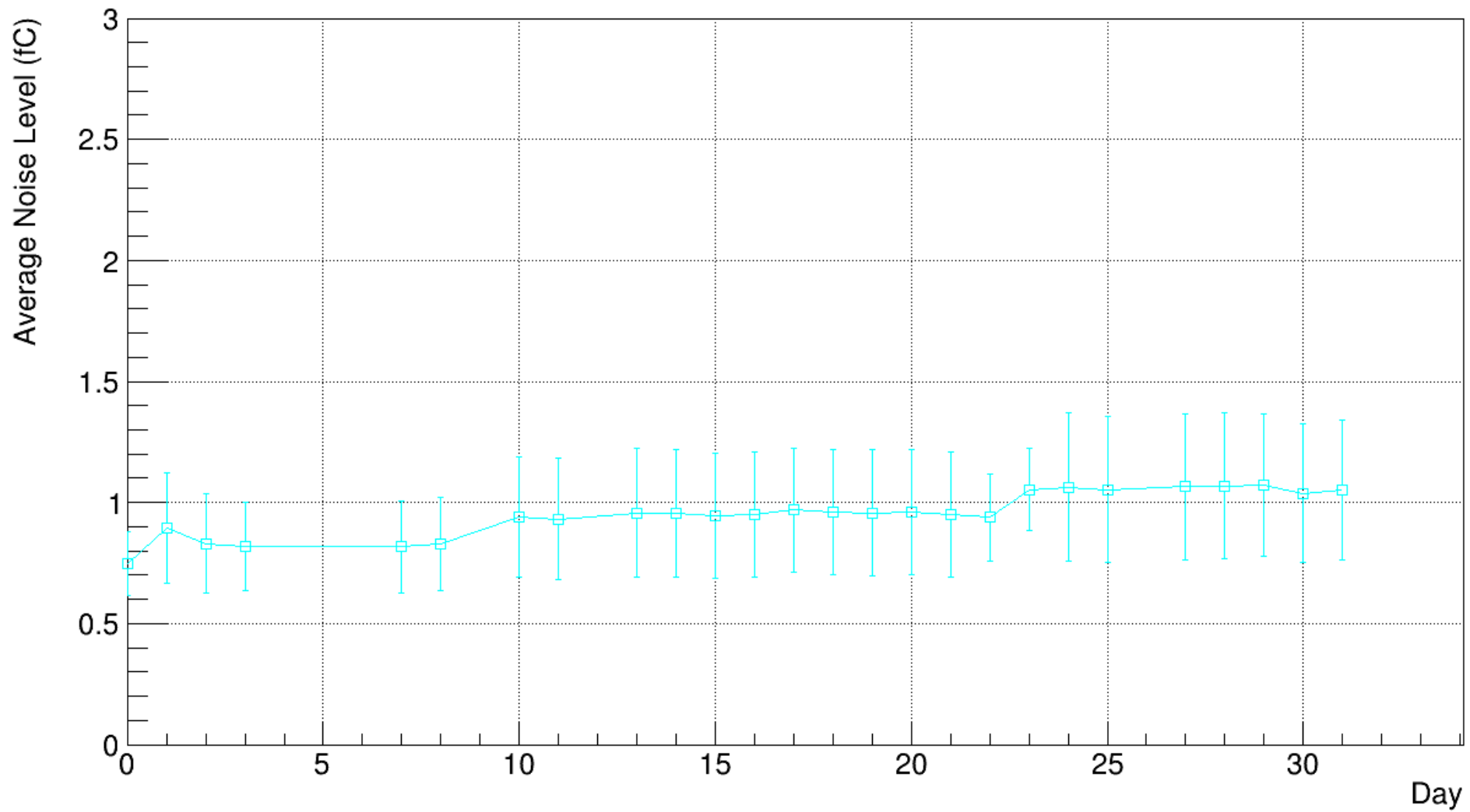

# tgr\_6\_e\_branch

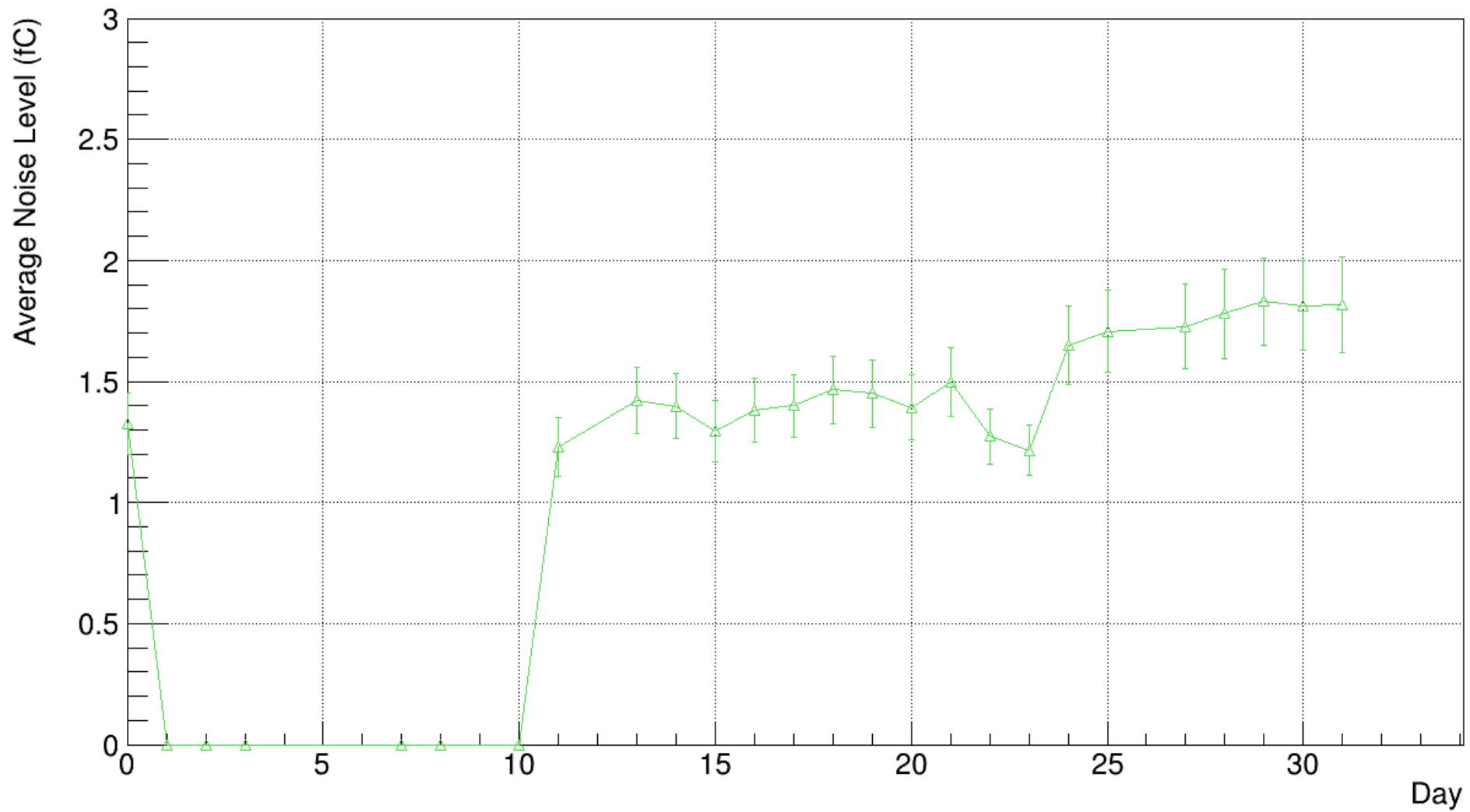

# tgr\_6\_t\_branch

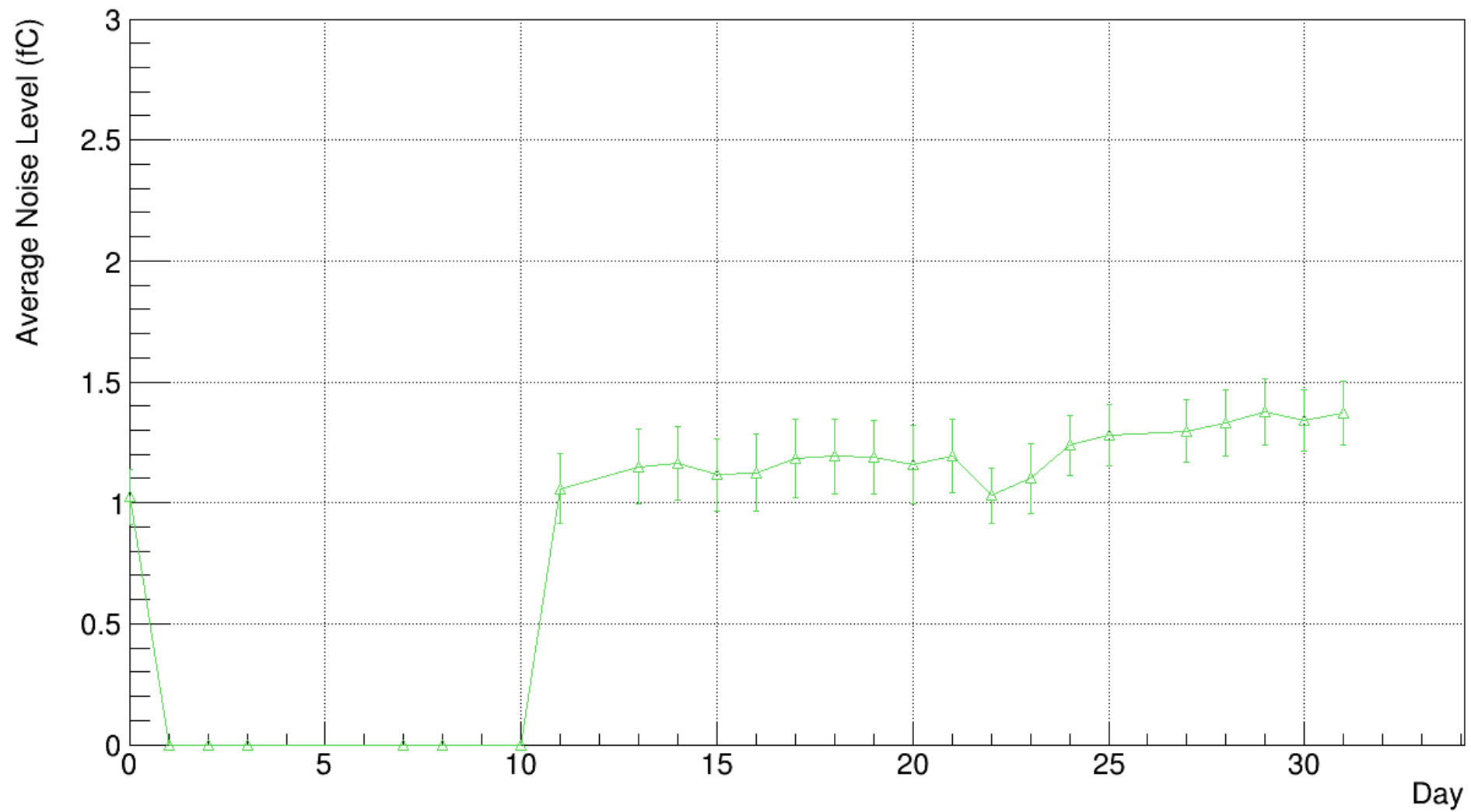

# tgr\_7\_e\_branch

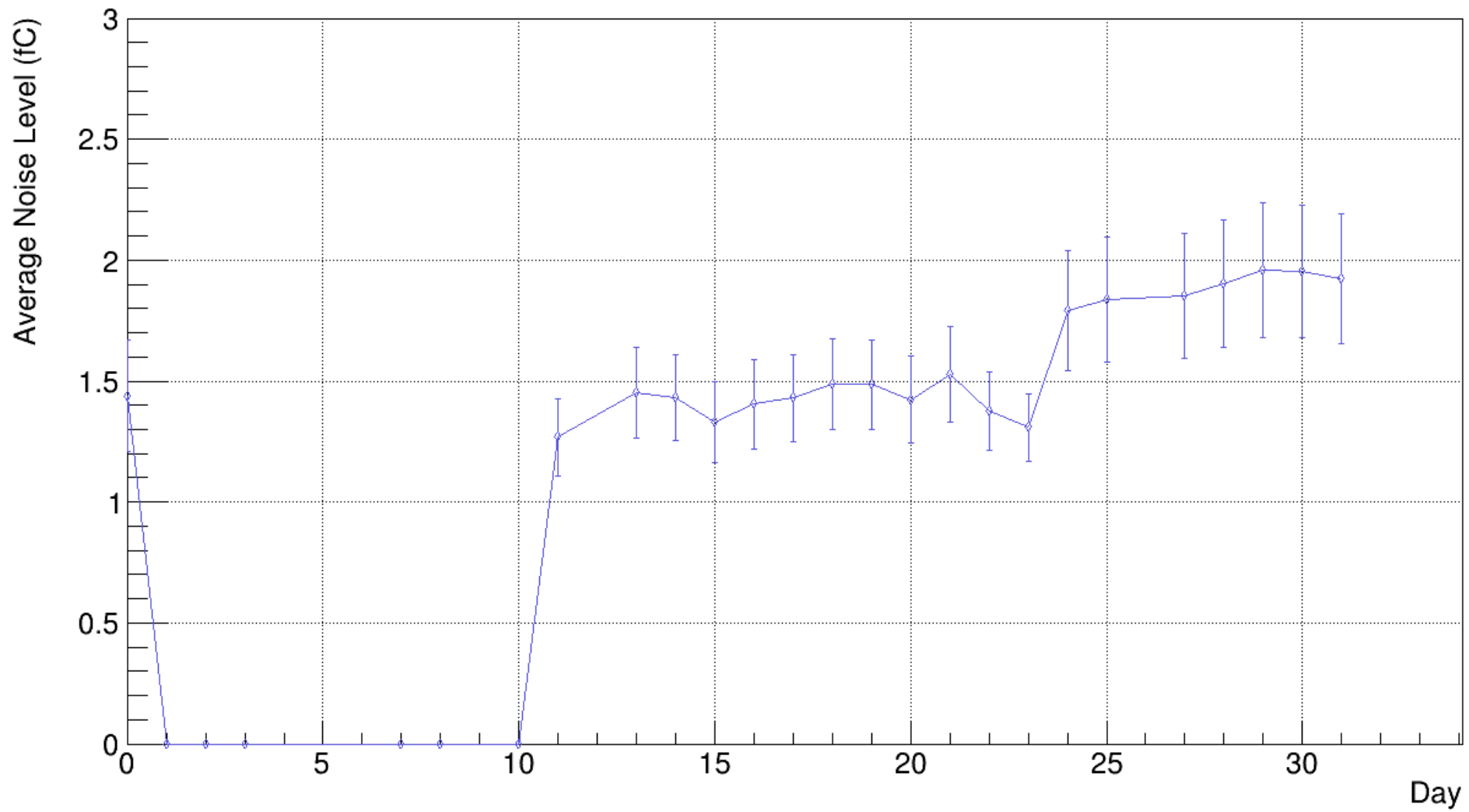

# tgr\_7\_t\_branch

