



Muon collider (feasibility studies)

**Materiale da Donatella
Lucchesi, Barbara Mele**

Muon Collider Proposals and ideas

- ❑ Muon produced from hadrons, mainly π decay, full and detailed study performed by MAP, [Muon Accelerator Program](#) for the Higgs factory and for the 1.5 and 6 TeV center of mass energy collider.
- ❑ Main difficulty is the muon cooling in particular at high energy, see MICE activities
- ❑ Recent similar proposal by Carlo Rubbia for the ESS facility



New ideas

- I. γ -p collision at LHC or FCC, with from an X-ray Free Electron Laser and multi-TeV proton. The boosted π are produced with low emittance and decay immediately to μ .
[L. Serafini et al. arXiv:1507.06626](#)
- II. γ -PSI (Partially Stripped Ions) collisions at LHC or FCC –“Gamma Factory”. Here e^\pm and μ^\pm produced directly. [W. Krasny arXiv:1511.07794](#)
- III. Use the high flux of positrons from II as beam for IV
- IV. e^+ annihilation on target, Low Emittance Muon Source, LEMMA.

For a summary [Muon Collider Workshop @Padova](#)

Low Emittance Muon Source Idea

3

Exploit $e^+ e^- \rightarrow \mu^+ \mu^-$ at \sqrt{s} around the $\mu^+ \mu^-$ threshold, $\sqrt{s} \sim 0.212$ GeV, in asymmetric collisions to generate beams of μ^+ and μ^-

Pro's

1. **Low emittance:** muon emission angle respect to the beam, θ_μ , is tunable with \sqrt{s} , it can be very small around the $\mu^+ \mu^-$ production energy threshold
2. **Energy spread:** muon energy spread small at threshold, it gets larger as \sqrt{s} increases, but not small enough for Higgs factory
3. **Low background:**
 - muon can be produced with a relatively high boost in asymmetric collisions reducing losses from decay
 - low emittance allows high luminosity with modest muon fluxes \Rightarrow low background and low ν radiation therefore we can reach high energy

Con's

Low Rate: $\sigma(e^+ e^- \rightarrow \mu^+ \mu^-) \approx 1\text{mb}$ (at most), to be compared to $\sigma(\text{ph} \rightarrow \mu^+ \mu^-) \approx \text{mb}$

The possibility to use low energy $e^+ e^-$ beams is not viable, it requires luminosity $\approx 10^{40} \text{ cm}^{-2} \text{ s}^{-1}$
Positron on target are considered

Three groups are working on three different items:

- I. Assess physics possibilities for an high energy muon collider. Muon collider allows to reach tens of TeV.
- II. Determine the detector performances under the effect of the high level of background and study the hazard due to neutrino interaction with the environment
- III. Produce a design concept machine that goes from high positron beam production up to muon beam injection the the colliding ring

Physics Possibilities

"equivalent" reach in pp after rescaling for pdf's

6

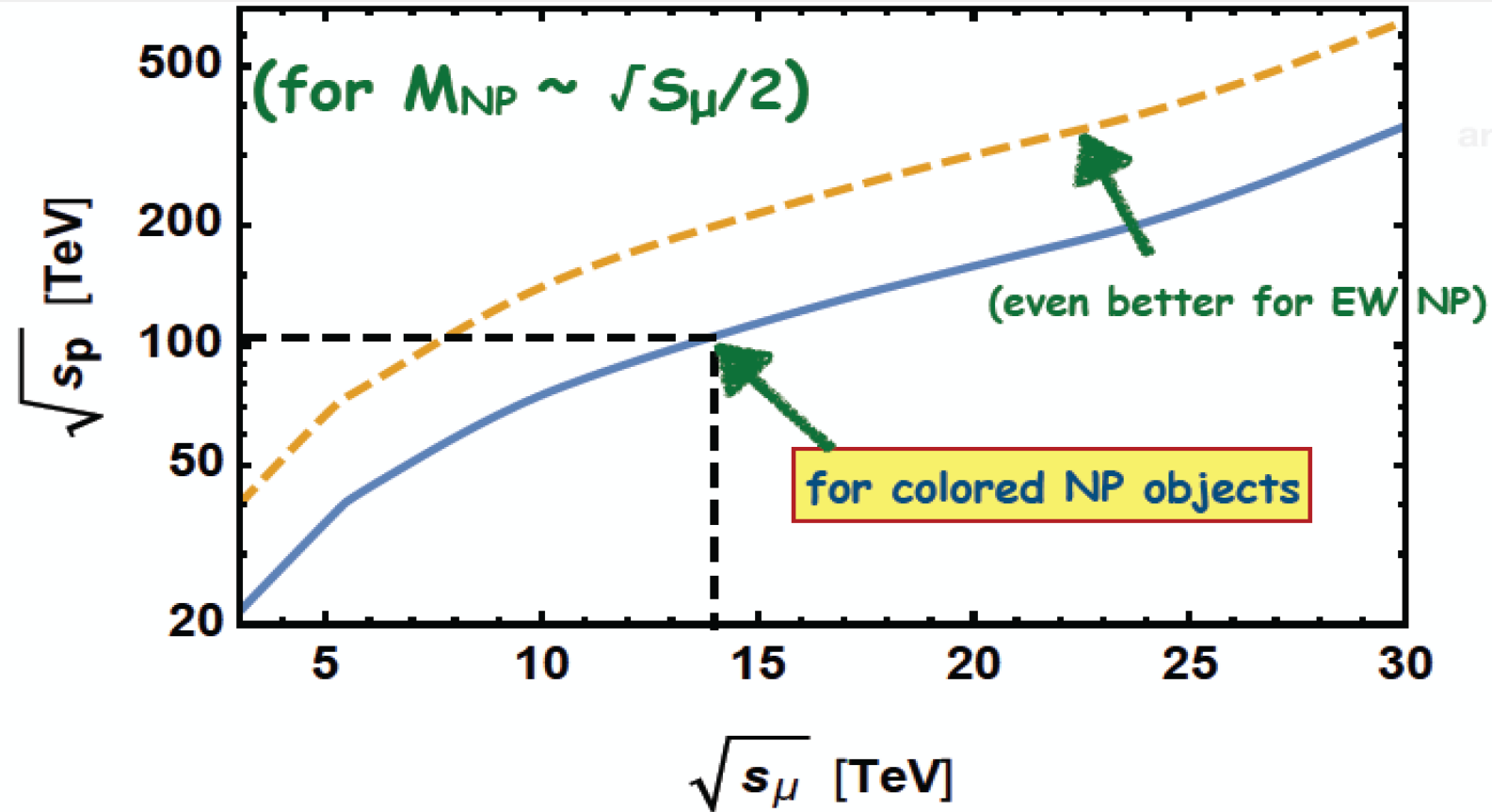

- * $\mu\mu$ collisions at 14 TeV \sim pp at 100 (200)_{EW} TeV !
- * at 30 TeV \sim pp at 350 (600)_{EW} TeV !!

New Studies of Multi TeV Muon Collider Physics Possibilities

B. Mele, F. Maltoni, F. Piccini, M. Chiesa et al. are studying really brand new physics possibilities for high energy muon collider.

plenty of Higgs's with $L \sim 10 \text{ ab}^{-1}$

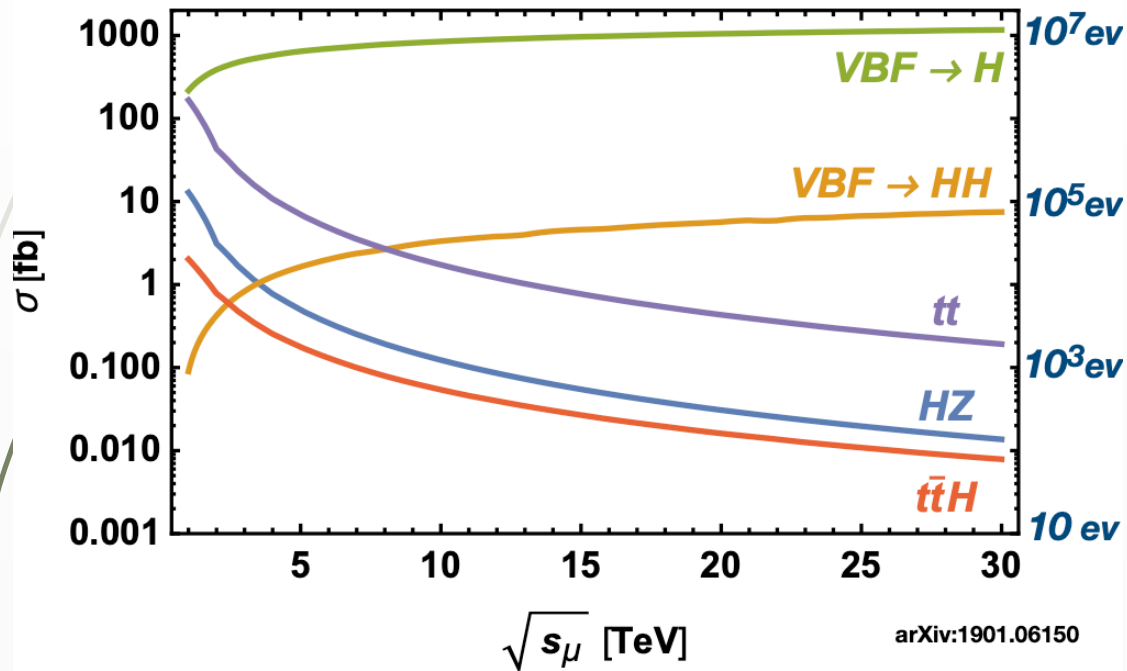

quadrilinear Higgs coupling in $\ell^+\ell^-$

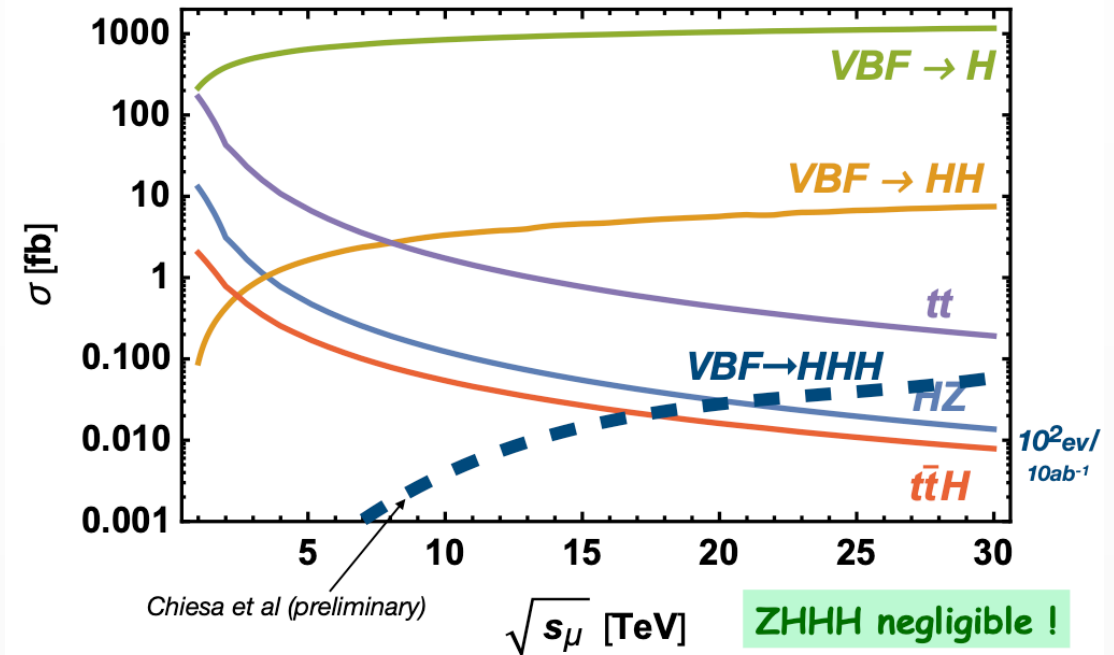

Machine Background and Detector Performances

MAP Studies: Neutrino Radiation Hazard

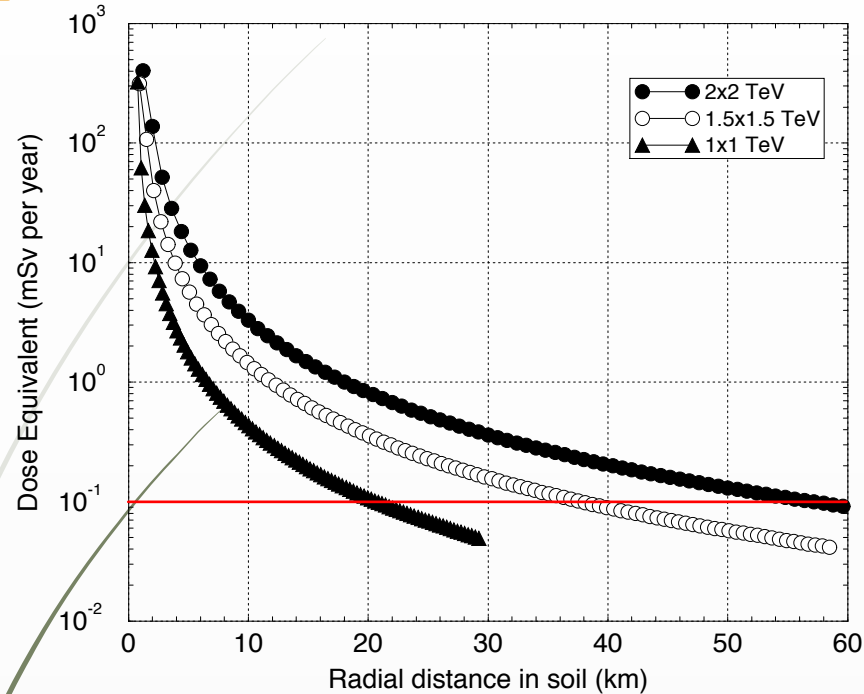

Figure 8: Maximum dose equivalent in TEP embedded in soil in high-energy muon collider orbit plane with 1.2×10^{21} decays per year vs distance from ring center.

TEP= tissue-equivalent phantom

- Intense highly collimated neutrino beams, as those created from muon decays at high-energy muon colliders, cause significant radiation problems even at very large distances from the machine
- Detailed simulation performed with MARS assuming the machine optics

Nikolai Mokhov et al.
 Published Proceedings of ICRS-9 International Conference on Radiation Shielding, Tsukuba, Ibaraki, Japan, October 17-22, 1999

MAP Studies: Interaction region and detector

Full study performed on 1.5 TeV machine

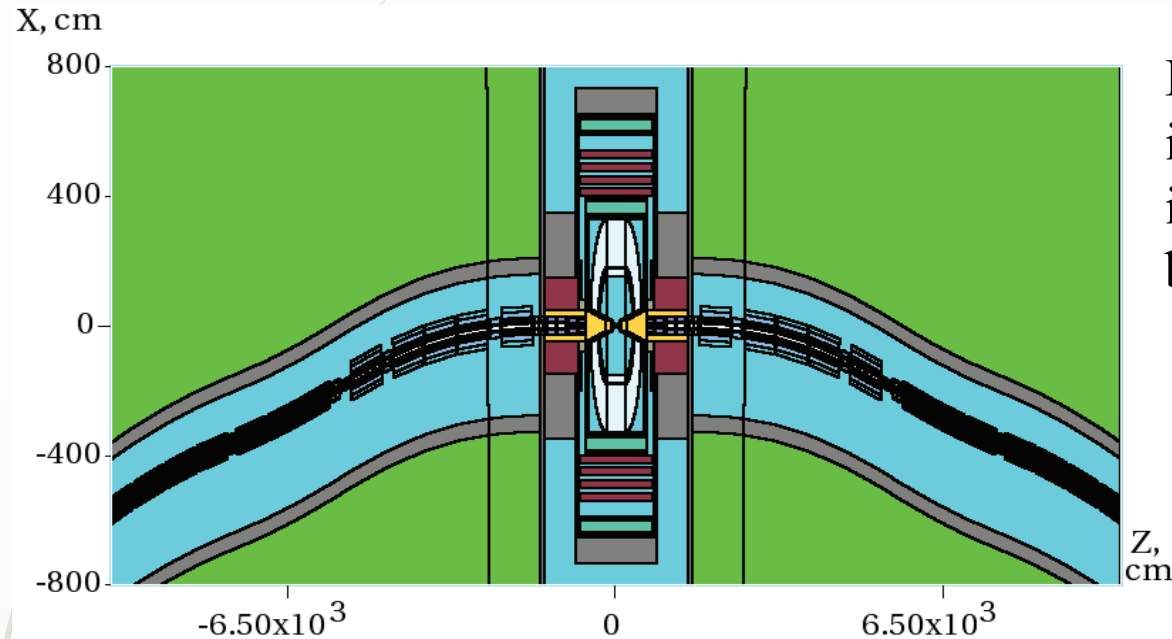

Tungsten Nozzles with proper angles are needed to reduce the background, they are part of the detector

TIPP 2011, Physics Procedia 37
(2012) 2015 – 2022

Interaction region High-field SC dipoles, interlaced with quadrupoles and tungsten shields implemented to reduce background, dominated by is muon decays

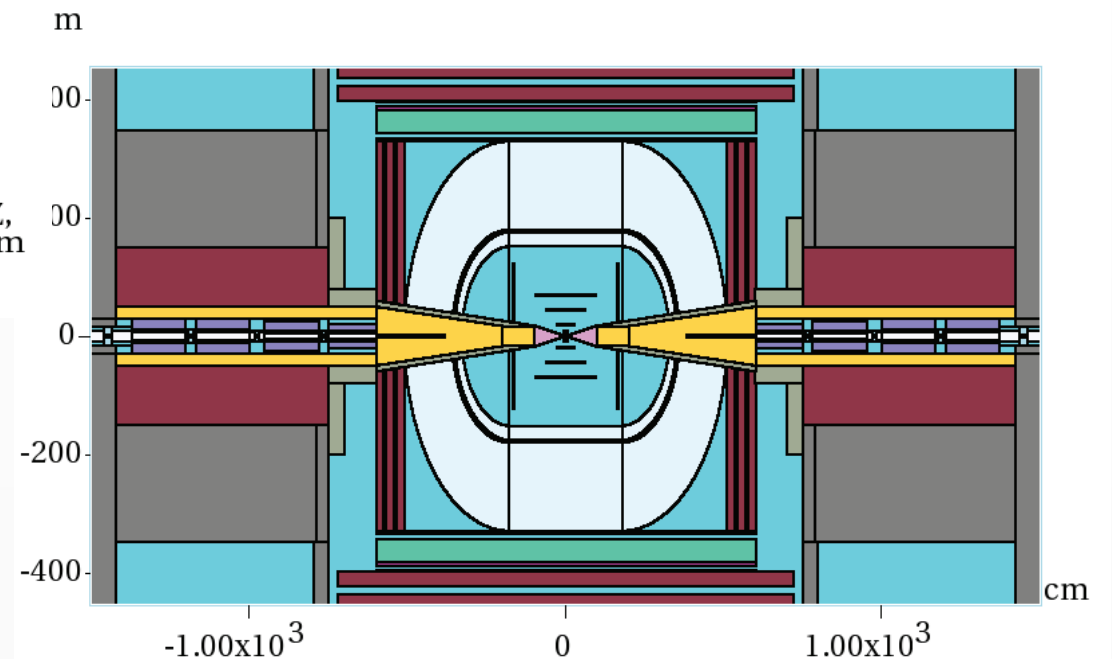

- Beam-induced background in the detector:
 - ▶ e^\pm from μ^\pm decays radiate synchrotron photons;
 - ▶ e^\pm and γ interact with machine components producing hadrons, secondary muons, e^\pm and γ .
- Currently we have a bkg sample for a 62.5-GeV beam, produced by N.V. Mokhov with MARS15 (<https://mars.fnal.gov/>) in the range $-10 \text{ m} < Z_{\mu \text{ decay}} < 30 \text{ m}$.

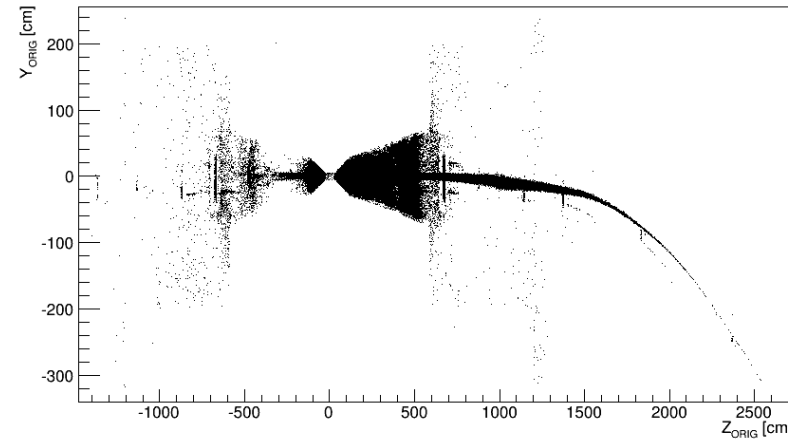
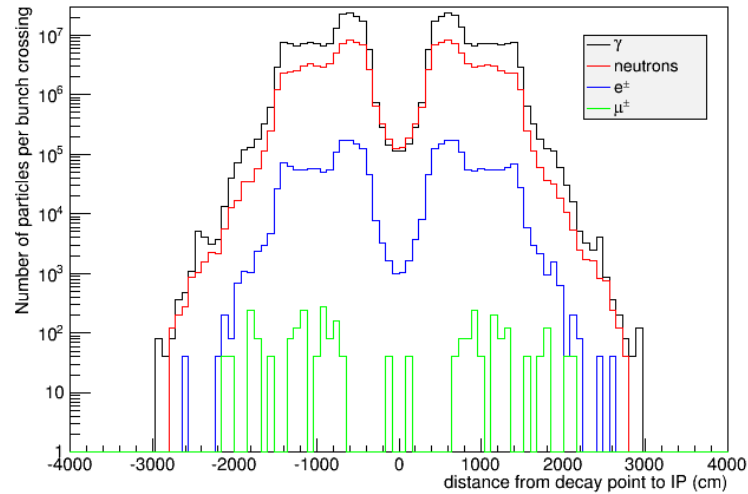
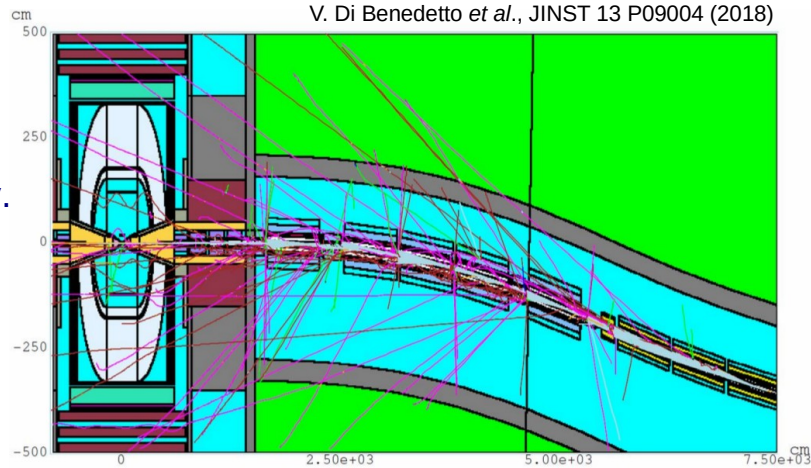

- Modelled in the ILCroot framework, response simulated with GEANT:

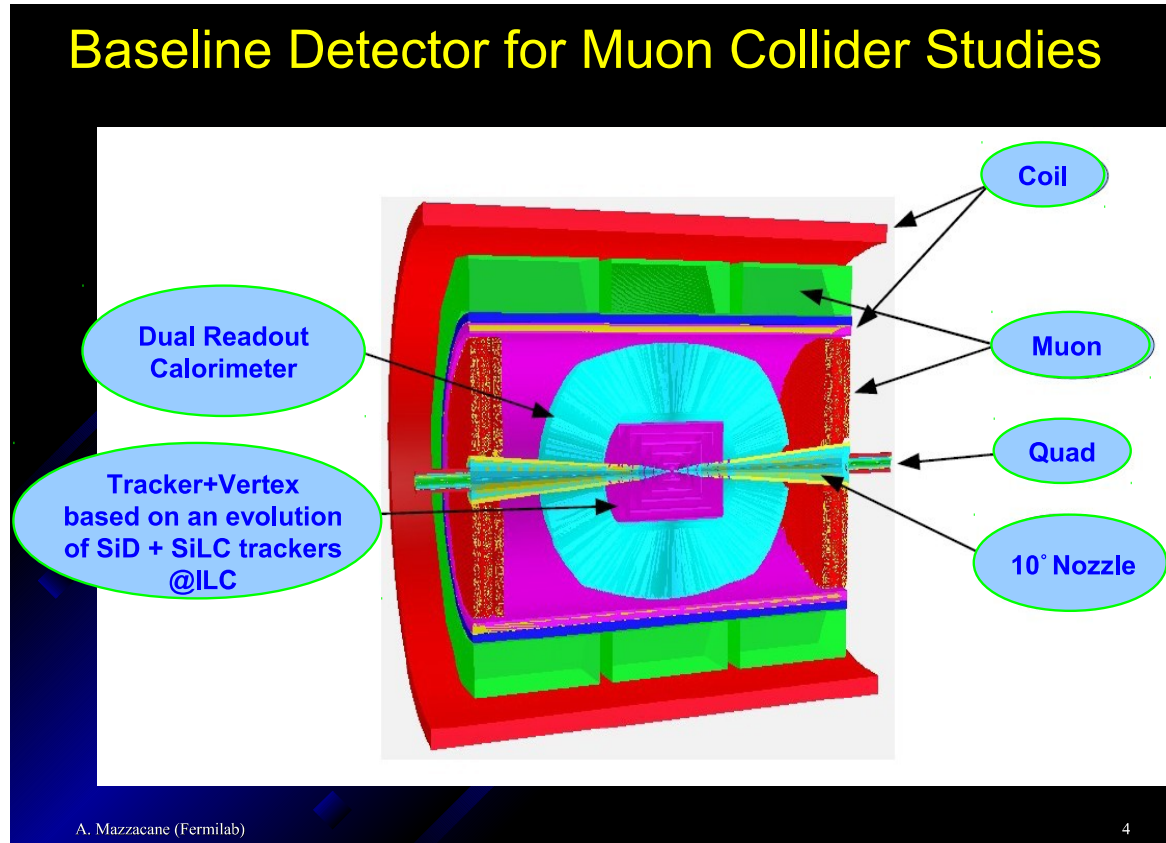

- ▶ Vertex detector:
 - ◆ 20x20 μm^2 Si pixels;
 - ◆ 5 barrel layers at $5.4 \text{ cm} < r < 15.4 \text{ cm}$;
 - ◆ 4 + 4 endcap disks, $|z| < 42 \text{ cm}$.
- ▶ Si tracker:
 - ◆ 50x50 μm^2 Si pixels;
 - ◆ 5 barrel layers at $19.5 \text{ cm} < r < 121.5 \text{ cm}$;
 - ◆ (4+2) + (4+2) endcap disks at $|z| < 165 \text{ cm}$.
- ▶ Dual readout calorimeter:
 - ◆ lead glass + scintillating fibers;
 - ◆ fully projective geometry with $\sim 1.4^\circ$ tower aperture angle;
 - ◆ depth: $>100 X_0$ and $\sim 7.5 \lambda_{\text{int}}$.
- ▶ Muon spectrometer:
 - ◆ precision drift tubes.
- ▶ Shielding nozzle:
 - ◆ tungsten core with a borated polyethylene coat.

$\mu^- \mu^+ \rightarrow H \rightarrow b\bar{b}$ reconstruction

- Reconstructed jets (tracks only) in a sample of 100 $H \rightarrow b\bar{b}$ events with no background.

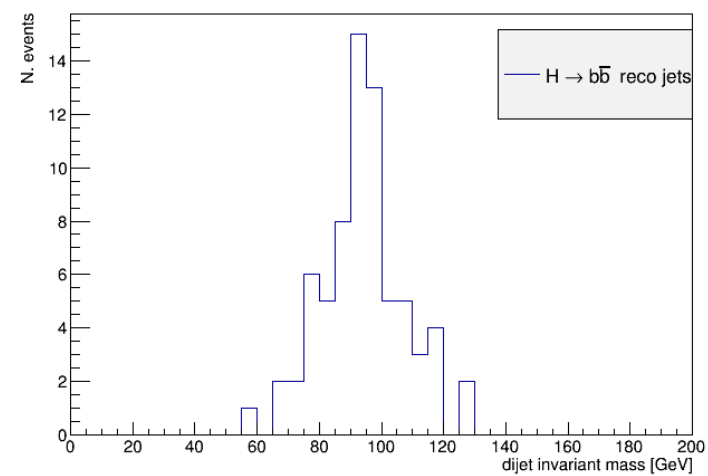
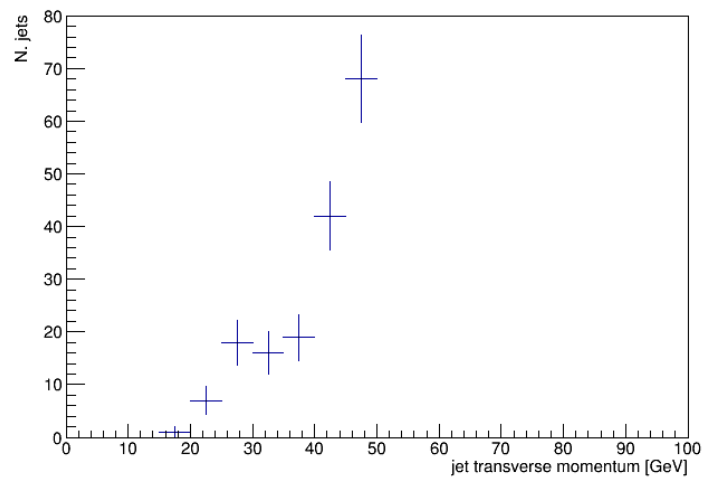
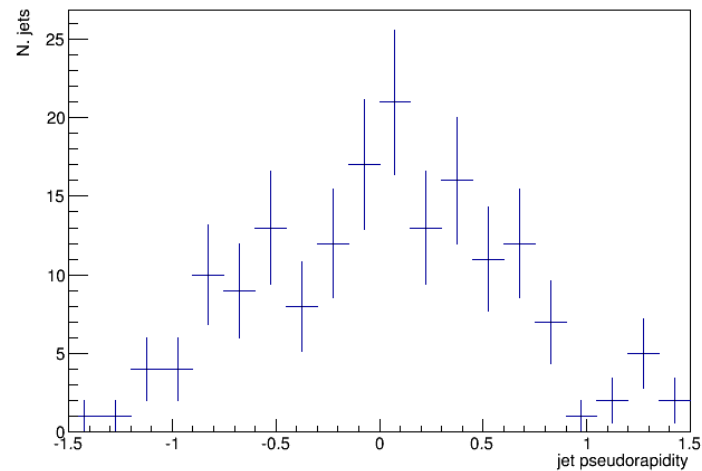

Accelerator Complex Design Concept

Low EMittance Muon Accelerator

Original proposal

Snowmass 2013 - M. Antonelli e P. Raimondi

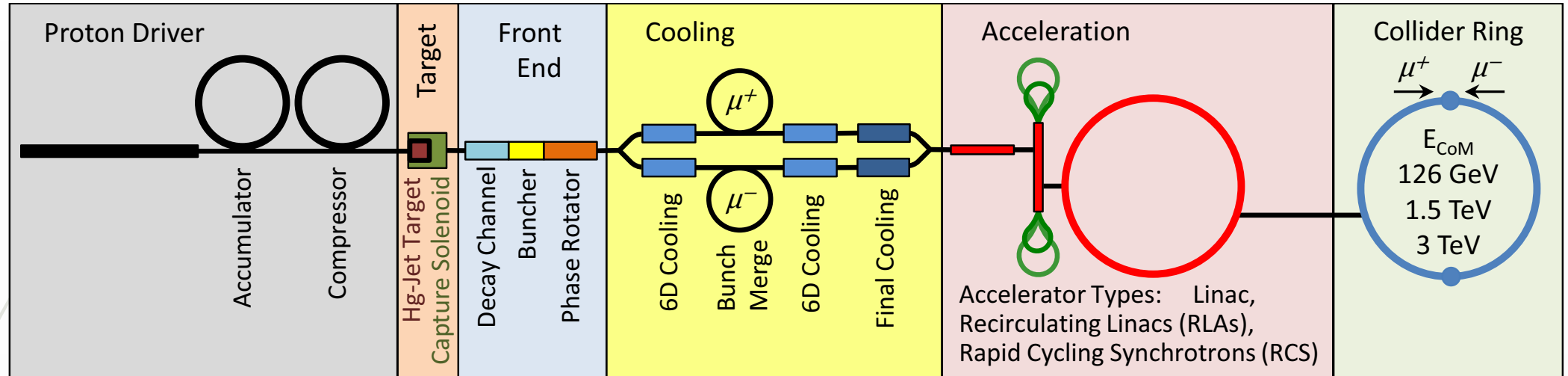

becomes

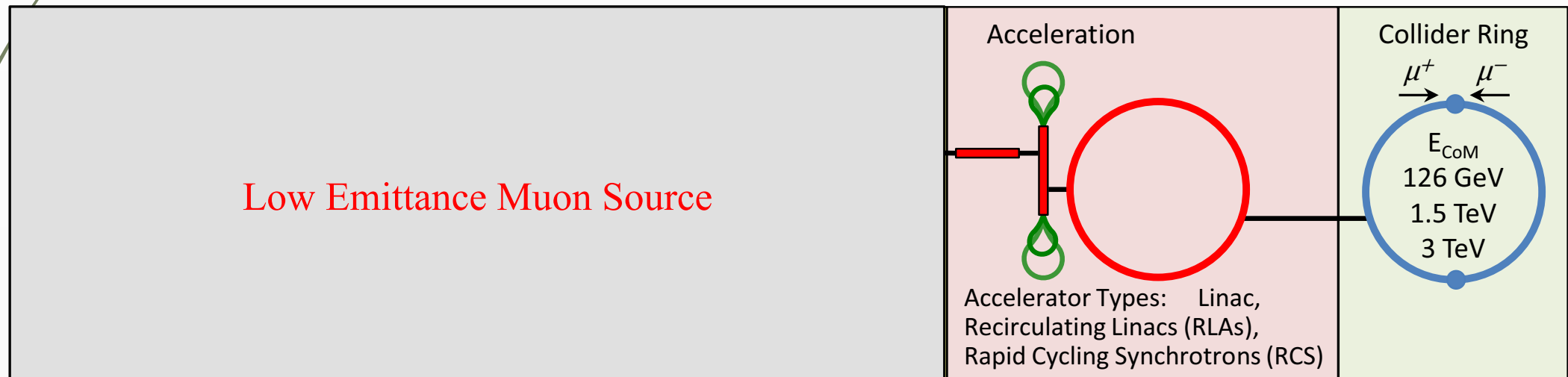

Possible Schema for Low Emittance Muon Source

16

Max n of bunches,
 $3 \cdot 10^{11}$ e⁺ / bunch,
 average current 0.5 Amps

Extendible to 3000
 bunches
 or more.. Sync Power

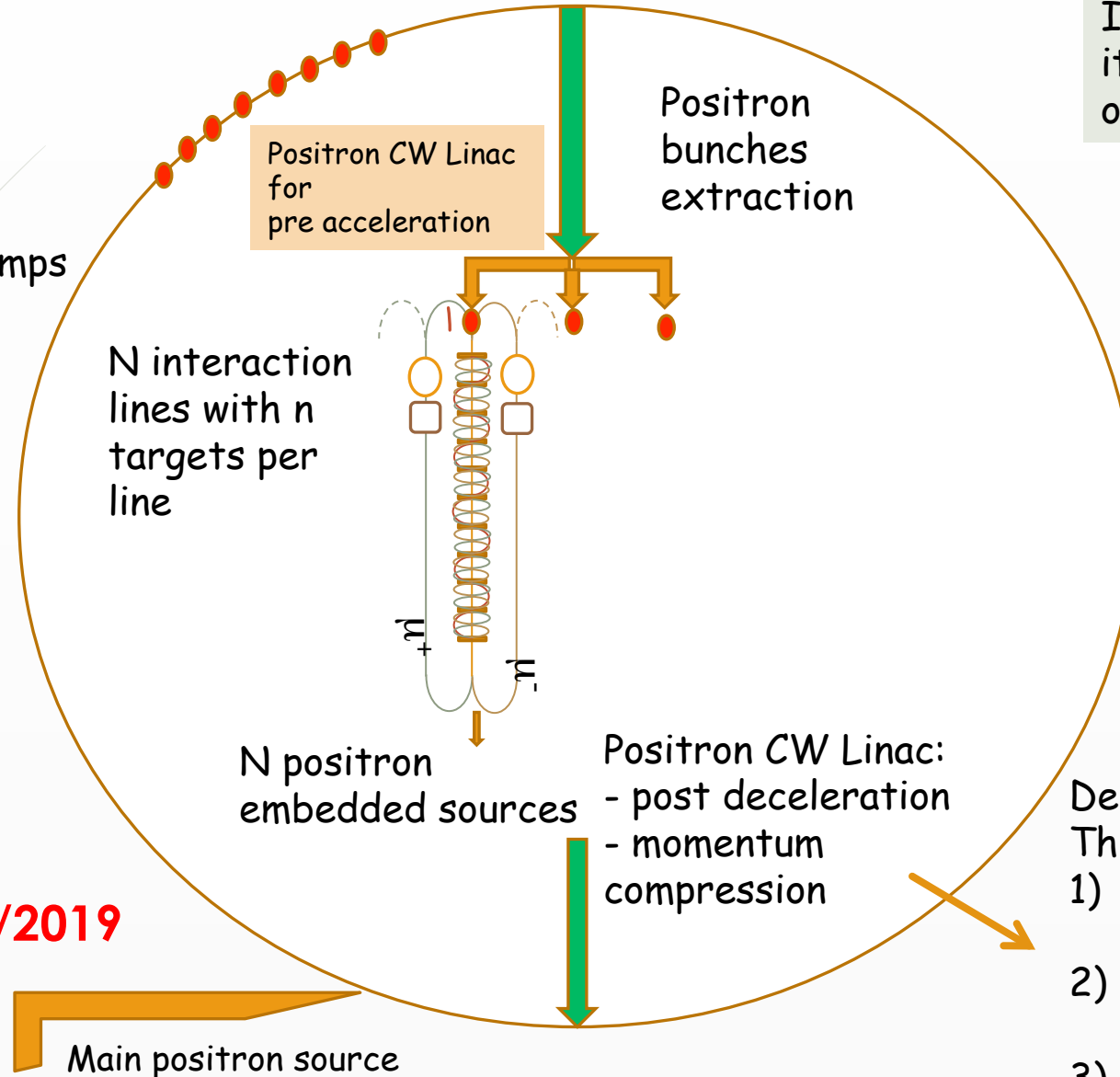

If with high average current
 it is mandatory to lower the energy
 of the main ring for the sync power

27 / 100 km ring
 LHC / FCC

Constraint for Be ->
 $T/2 (3 \cdot 10^{10} \text{ exp}^4 / \text{thick (in \%X0)})$
 $< 200 \mu\text{s}$

- Depending on the Linac energy
 This can be used for:
- 1) Positron recuperation and momentum compression
 - 2) Embedded sources positrons post acceleration and injection
 - 3) Muon beam fast post acceleration (ERL config.) for lifetime increasing

A. Variola
CSN1 31/01/2019

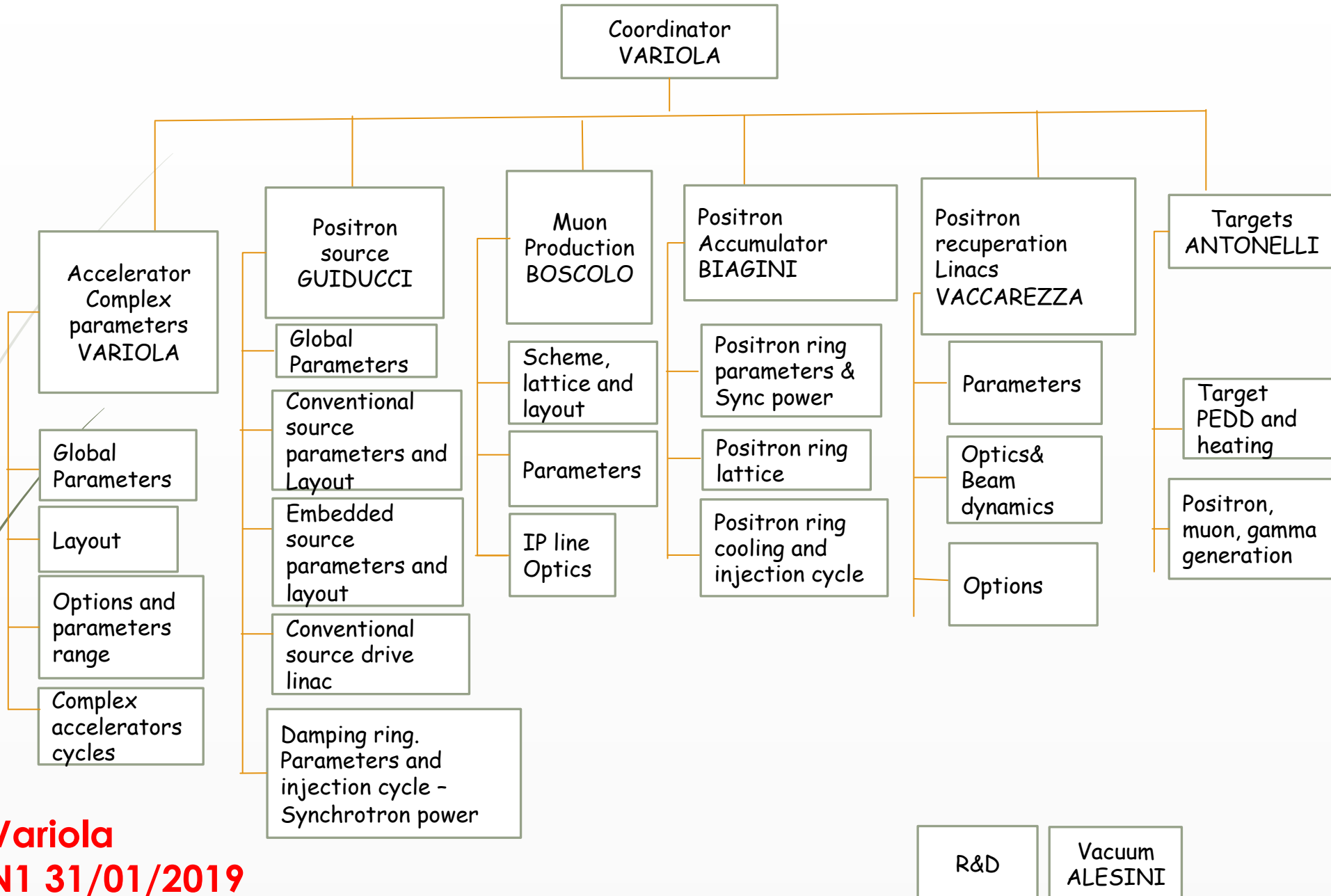

Comparison and Costs

Muon Colliders extend leptons high energy frontier with potential of considerable power savings

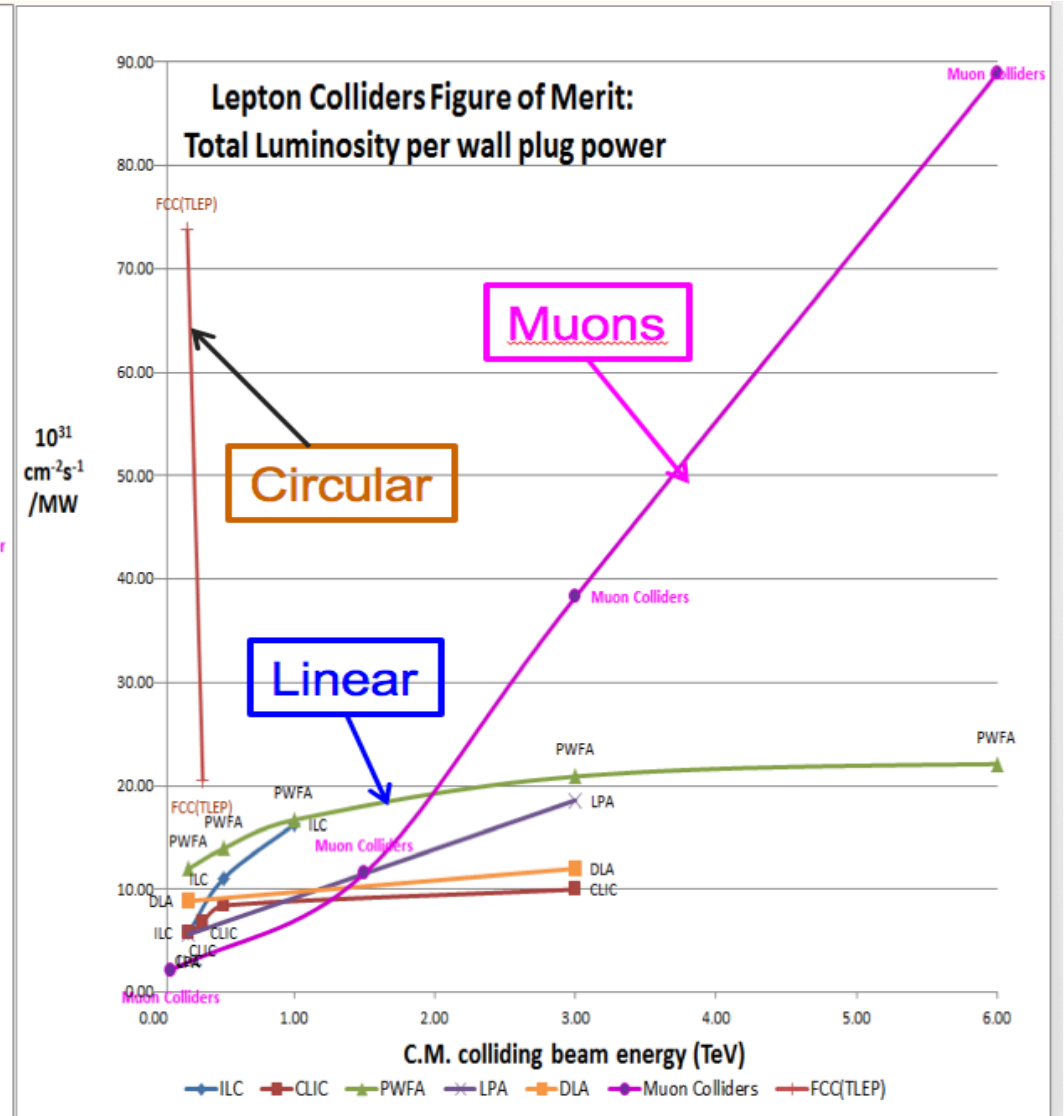
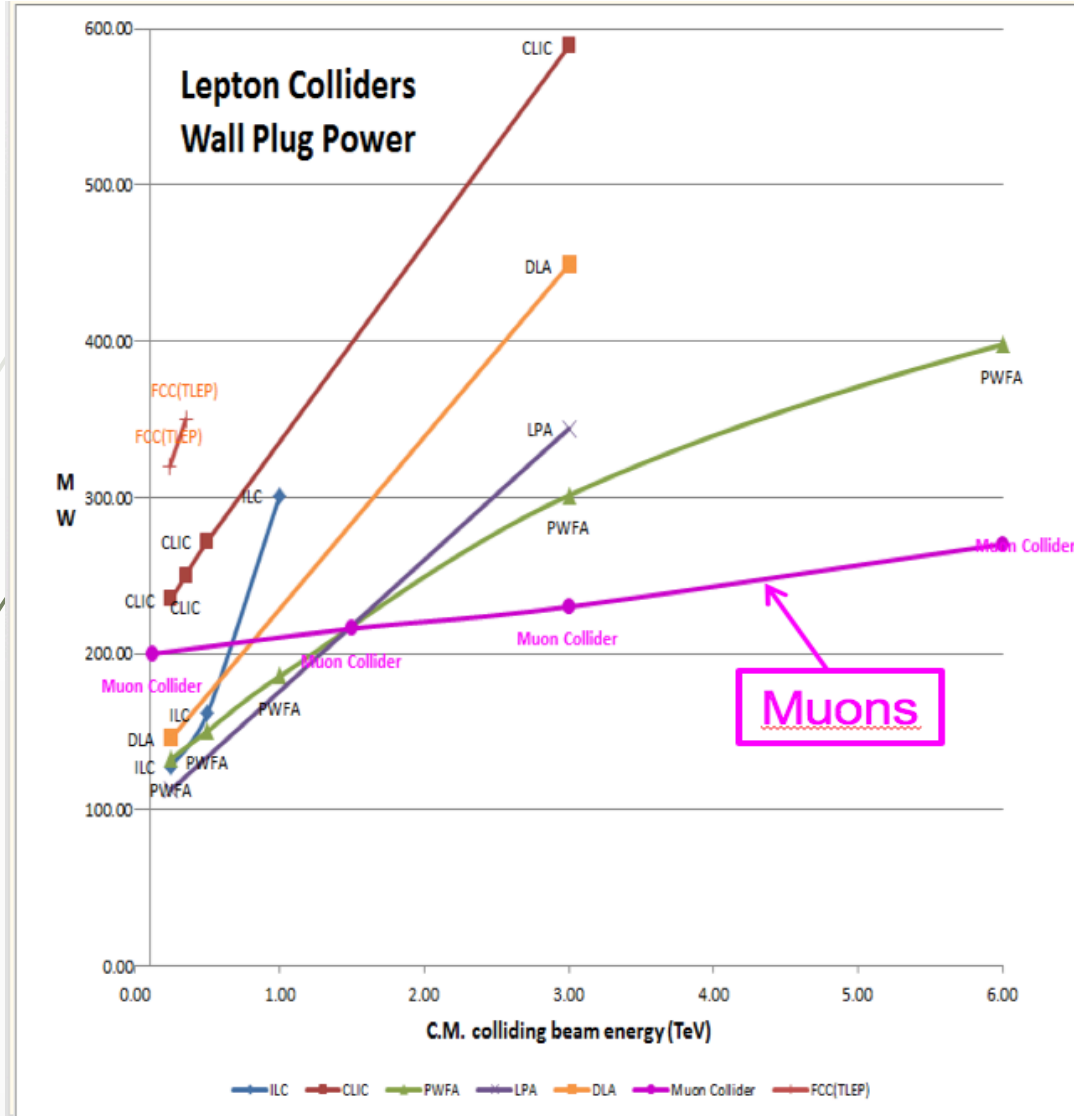

The comparison – a challenge

20

SIZE ISN'T EVERYTHING

In particle physics, bigger colliders generally achieve higher-energy collisions — and have higher costs. But a muon collider could reach high energies with a small footprint, and relatively low costs. It would also be much less complex than proposed alternatives, according to Fermilab physicist Vladimir Shiltsev, who has estimated the number of major technological components in four of the five machines illustrated here.

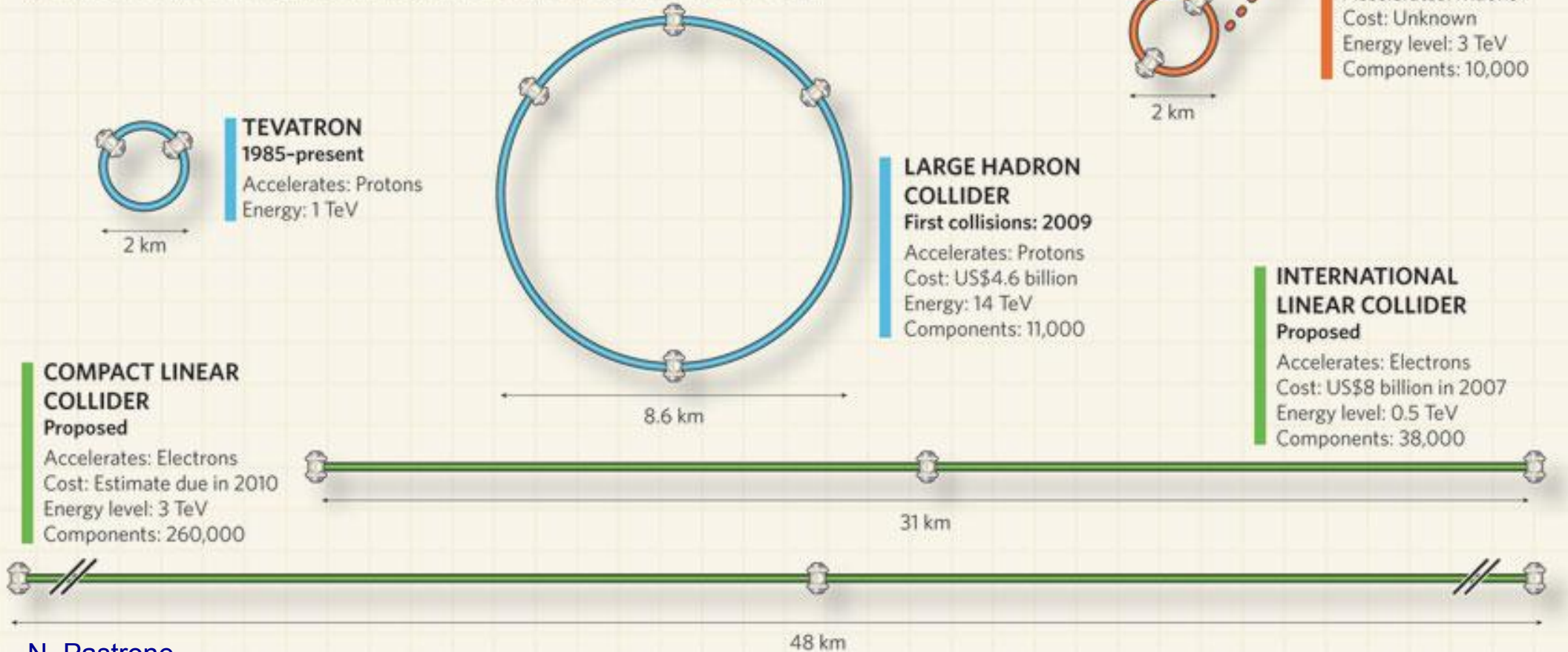

Nature - 2009

N. Pastrone
Vulcano 2018

Cost estimate

NB: all \$\$ - "US Accounting" (divide by 2-2.4 at CERN)

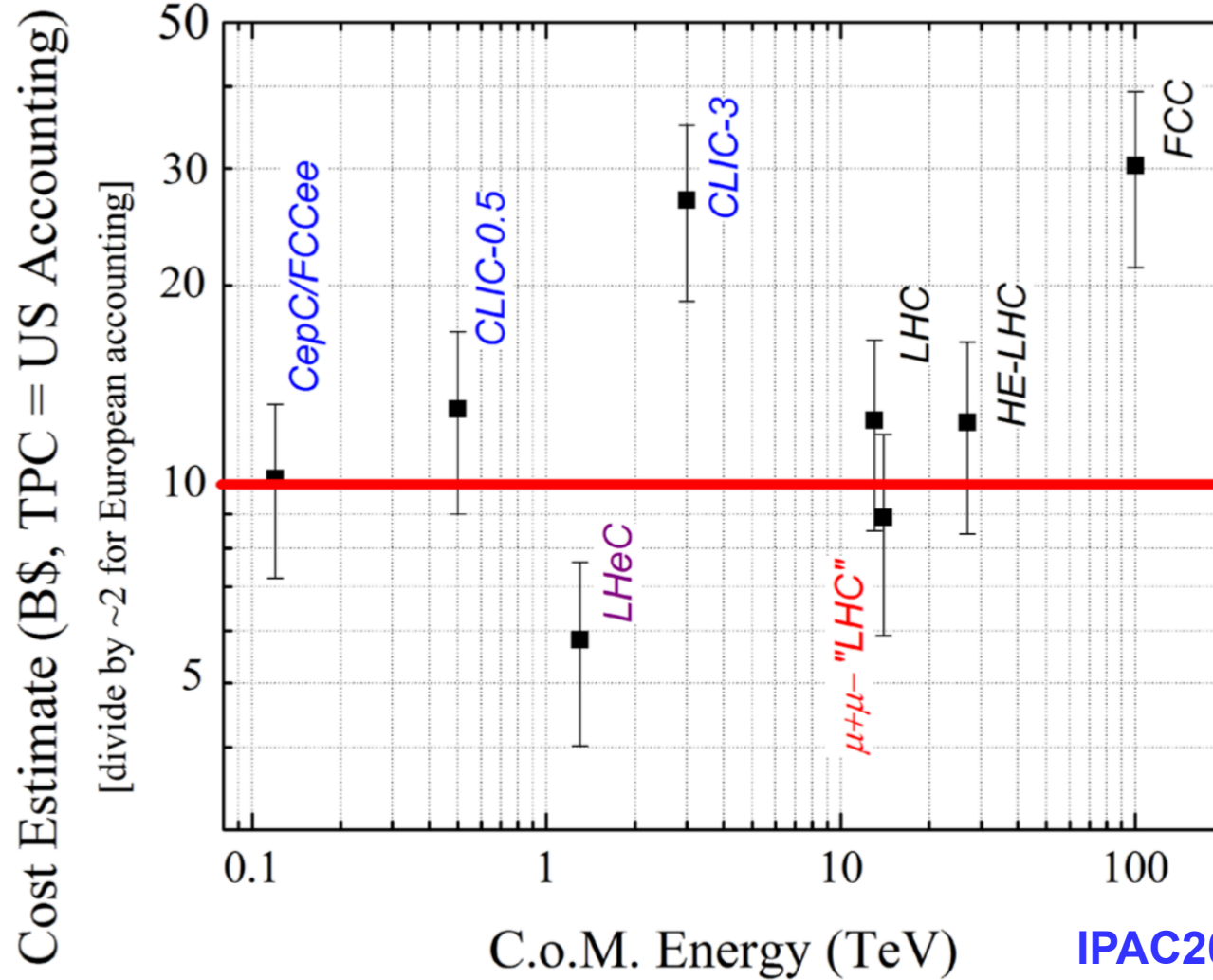

Vladimir SHILTSEV,
David NEUFFER (Fermilab)

IPAC2018 - MOPMF072

Summary

For the first time in several years the high energy physics path is not obvious.
A great occasion to make a big step forward!

The European Strategy update study started.

The discussion on the future collider machine will have to take into account everything:

- ✓ Physics reaches
- ✓ Costs
- ✓ Time from construction to physics results

Muon Collider is back on the table:

- several new ideas have been proposed among which the lepton muon production
- unique Higgs and new Physics measurements well within reaches
- novel accelerator technique, interesting by itself in addition technological developments can inspire new spin-offs
- great challenge at international level and fantastic opportunity for young people

Gruppi italiani in LEMMA

- Sedi coinvolte: FE, **LNF**, MI, PI, **PD**, RM1, **TO**, TS
- In totale ~8 FTE
- Percentuali basse per singolo (da 5%? A 30%)