

DANAE - a new experiment for direct dark matter detection using RNDR DEPFET detectors

Hexi Shi
HEPHY ÖAW

Workshop organized within the project :

*“Hunt for the ‘impossible atoms’:
the quest for a tiny violation of the Pauli Exclusion
Principle. Implications for physics, cosmology
and philosophy,”*

**ID 58158, funded by the John Templeton
Foundation**



DANAE (DANAË)

Direct dArk matter search using DEPFET with repetitive- Non-destructive-readout Application Experiment

OeAW funding for detector technology



“Danae” by G. Klimt

Collaboration



Austria

A. Bähr ^A, J. Ninkovic ^A, J. Treis ^A,
H. Kluck ^{B,C}, J. Schieck ^{B,C}, H. Shi ^B,



Germany

Max-Planck-Gesellschaft Halbleiterlabor, Germany ^A,

Institut für Hochenergiephysik der Österreichischen Akademie der Wissenschaften, Vienna, Austria ^B,

Atominstytut, Technische Universität Wien, Vienna, Austria ^C

The project overview

Direct Dark Matter Detection with DEPFET

- minimal reach for nuclear recoil experiments about few 100 MeV
- dark matter electron scattering offers **reach towards MeV dark matter**
- measurement of **low noise** ionisation signal in **low background** environment
- RNDR* DEPFET sensors developed by semiconductor laboratory of MPG
- setup for **proof-of-principle measurement** currently prepared
- expect first results early 2019**

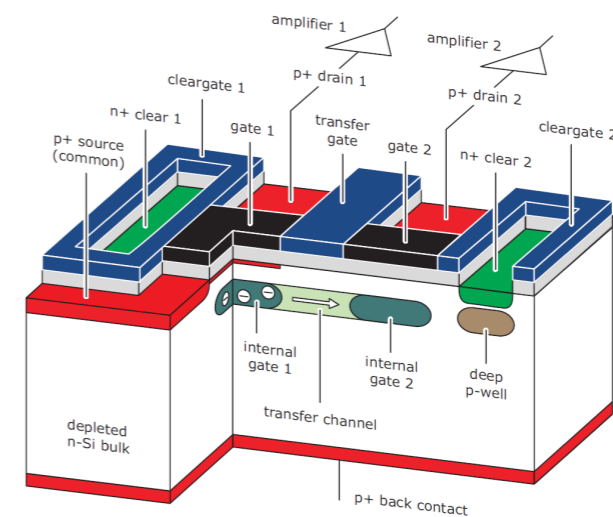
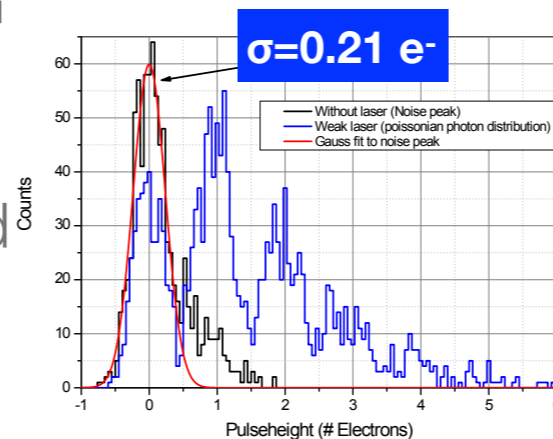
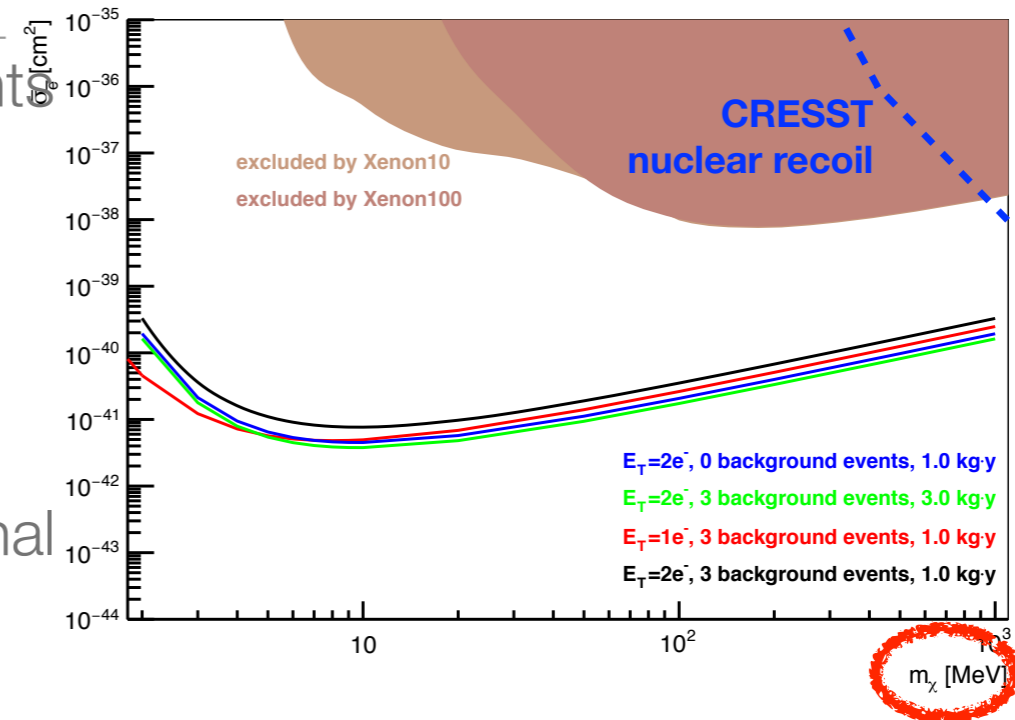

EPJ C, 77(12), 279 (2017)

*Repetitive Non-Destructive Readout

Dark matter landscape - partly

Over 80% of the mass in the universe is invisible dark matter

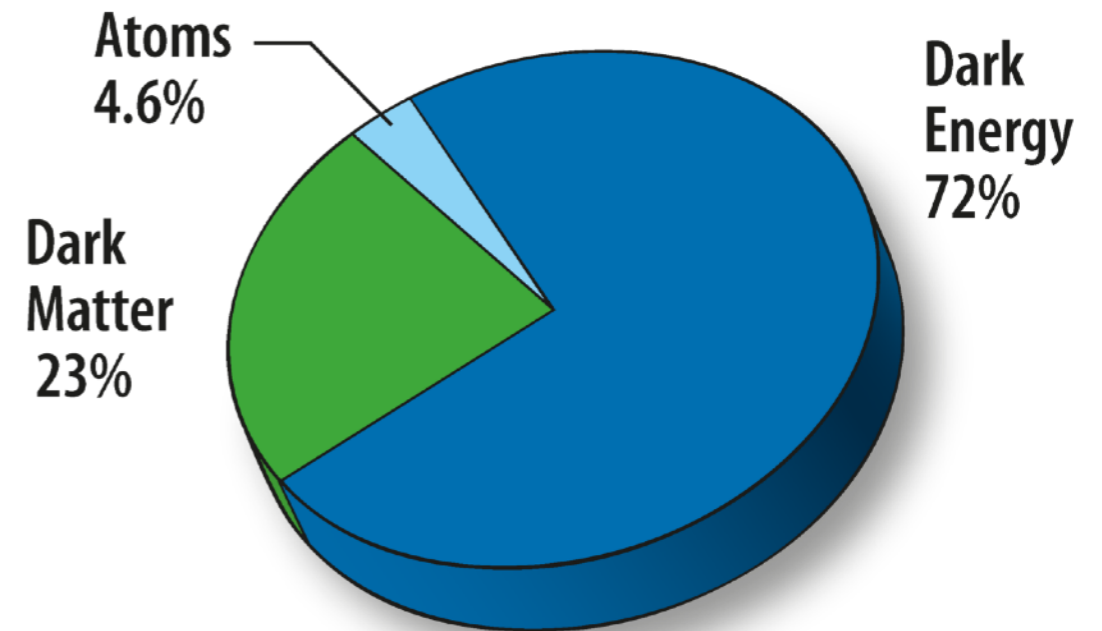

TODAY

Credit: NASA / WMAP Science Team

“WIMP” as a dark matter candidate :

- weakly interacting with matter

$$\langle \sigma_{\text{WIMP}} \cdot v \rangle \sim G_F^2 \cdot m_X^2 \sim 1/\Omega_X$$

- fits the Hubble constant and “relic” density of dark matter

predicts dark matter WIMP mass between 2 GeV and 120 TeV



WIMPs

dominated the direct detection experiments until recently

WIMP direct detection method

look for nuclear recoils from
WIMP-nucleus scattering

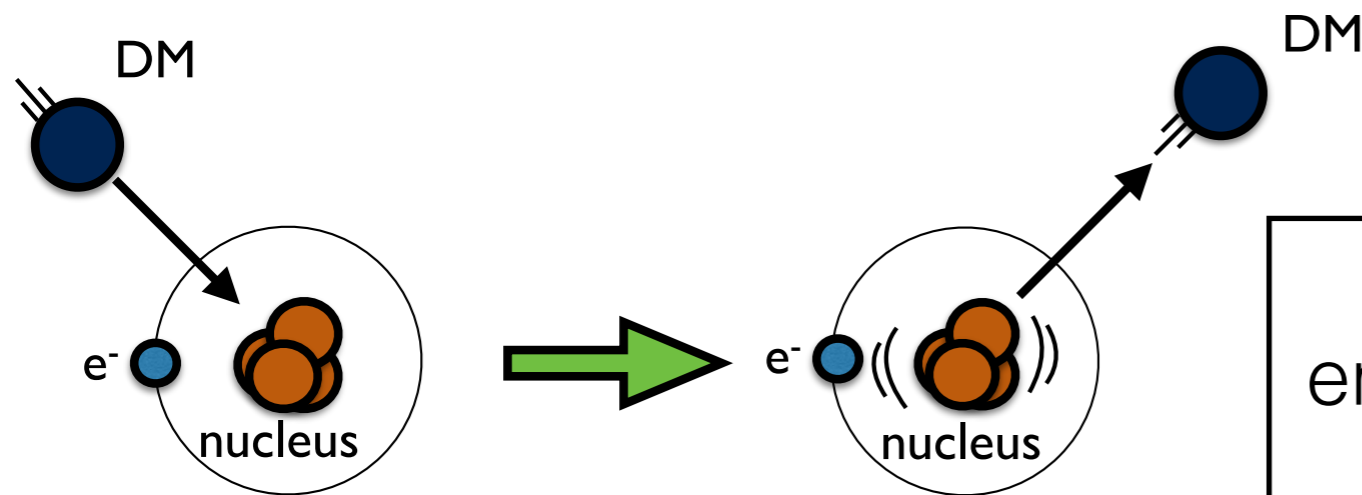

image credit R. Essig

Energy deposit in target
material in forms of :

- light
- phonon
- electric charge

Detection limitation :
energy deposit from nucleus recoil
 $E_{NR} \sim 2\mu_{\chi,N}^2 \cdot v_{\chi}/m_N$

-> for 100 MeV m_{χ} , $E_{NR} \sim 1$ eV *

plus quenching factors and
noise level of the detectors

typical DM velocity $v_{\chi} \lesssim 800$ km/s

*for silicon

DM-nucleus scattering direct search status

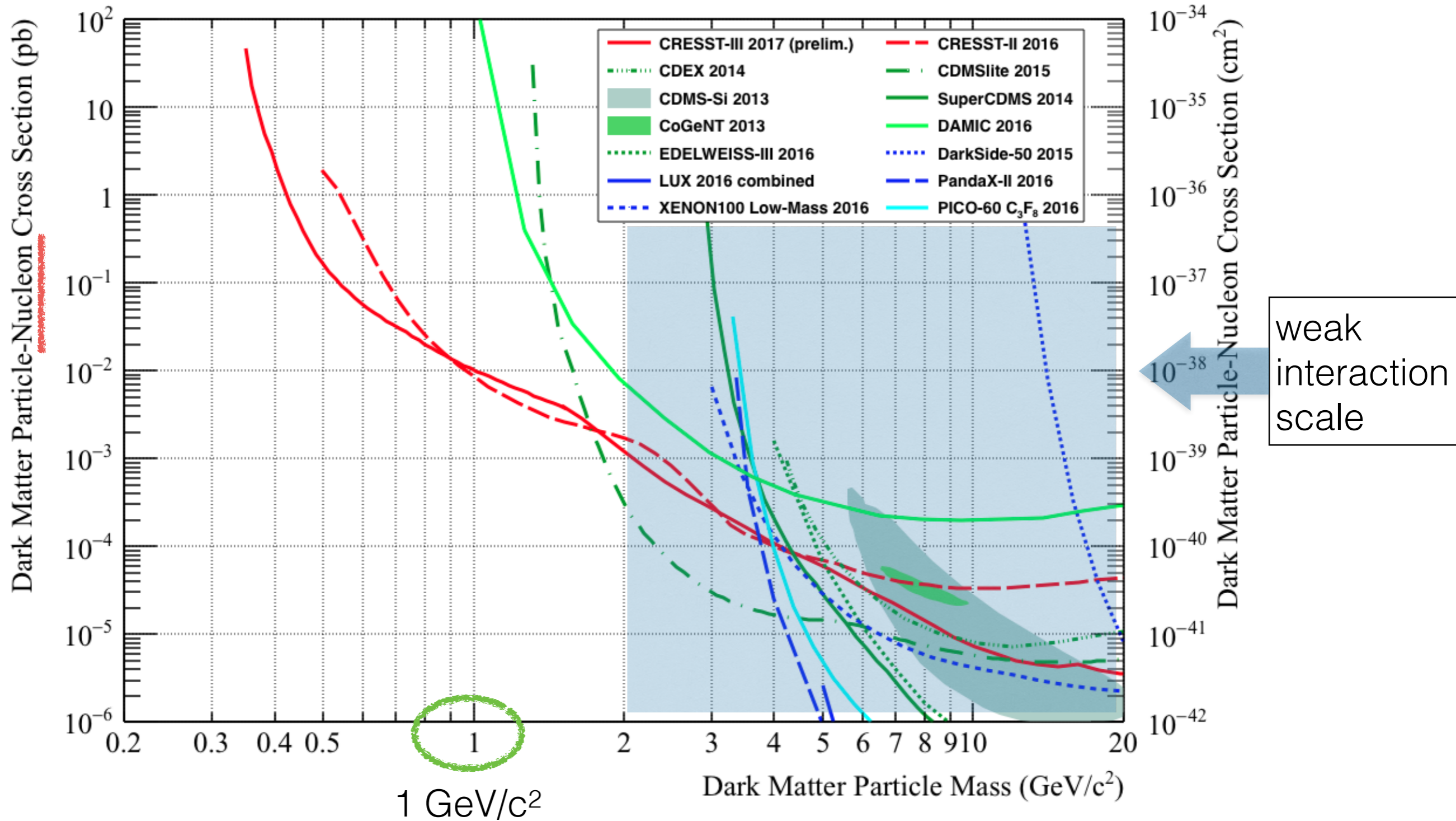

DM-nucleus scattering direct search status

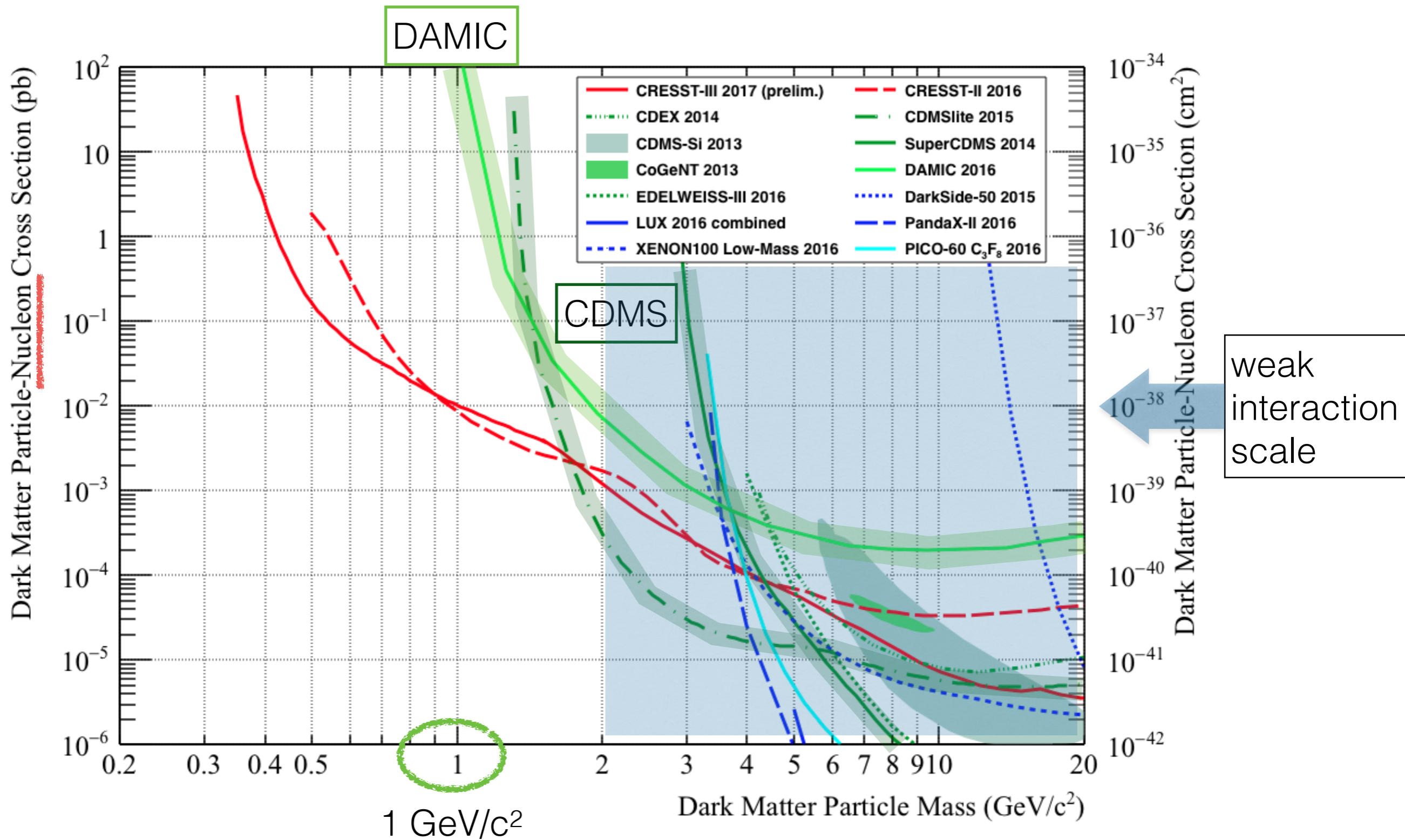

Dark Sector and Light Dark Matter



Dark sectors
(DM + new mediators)

WIMPs

several sharp “theory” targets
(freeze-out, asymmetric, freeze-in, SIMP, ELDER)

Dark sector :
interaction between DM and standard model particle mediated by a dark photon
(one example of mediators)

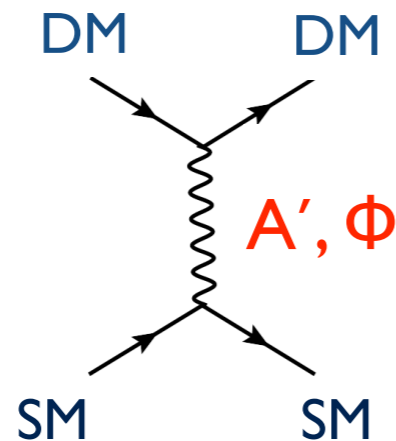

DM scattering

clear predictions from multiple models over wide DM mass region, including keV ~ GeV range
-> comparable observables in experiments

image credit R. Essig

DM-electron scattering

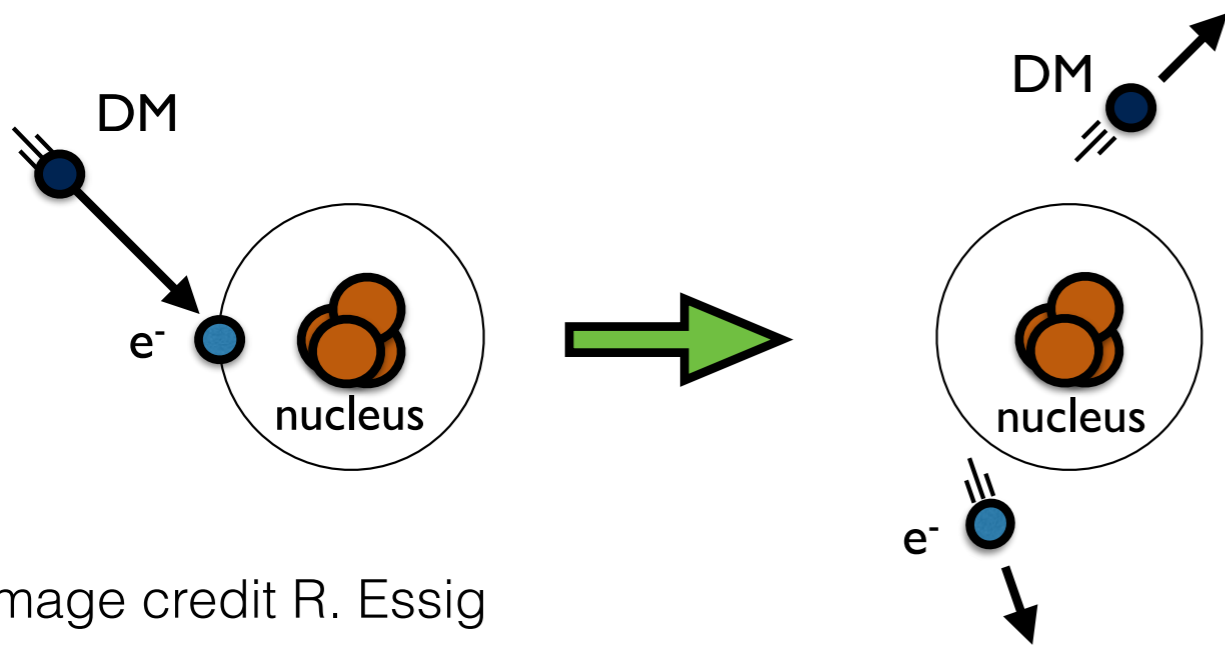

image credit R. Essig

kinematically

to overcome binding energy ΔE

need $E_{\text{DM}} \sim \frac{1}{2} m_{\text{DM}} v_{\text{DM}}^2 > \Delta E$

$$v_{\text{DM}} \lesssim 800 \text{ km/s} \implies m_{\text{DM}} \gtrsim 300 \text{ keV} \left(\frac{\Delta E}{1 \text{ eV}} \right)$$

O(100 keV)

DM-electron scattering

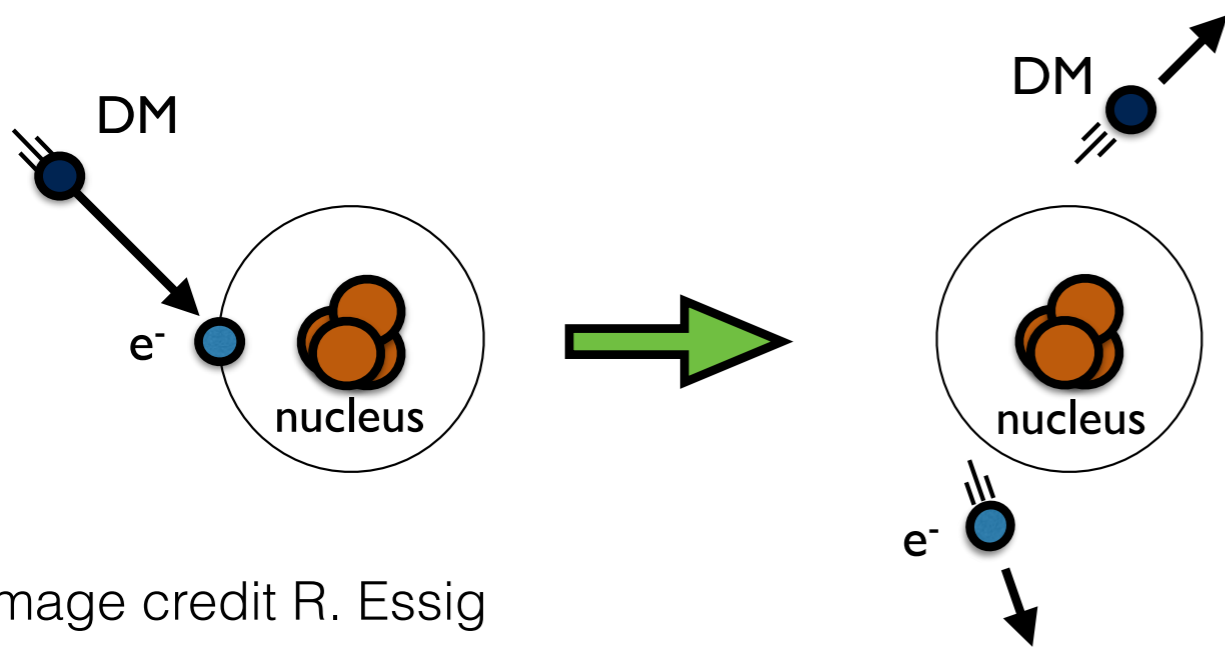

image credit R. Essig

kinematically

to overcome binding energy ΔE

need $E_{\text{DM}} \sim \frac{1}{2} m_{\text{DM}} v_{\text{DM}}^2 > \Delta E$

$v_{\text{DM}} \lesssim 800 \text{ km/s} \implies$

$$m_{\text{DM}} \gtrsim 300 \text{ keV} \left(\frac{\Delta E}{1 \text{ eV}} \right)$$

O(100 keV)

bound e^- does not have definite momentum,
typical momentum transfer is set by e^- not by DM.

$q_{\text{typ}} \sim \alpha m_e \sim 4 \text{ keV}$

(for outer shell electron)

transferred energy: $\Delta E_e \sim \vec{q} \cdot \vec{v}_{\text{DM}}$

$$\Delta E_e \sim 4 \text{ eV}$$

typical
recoil energy

Target materials for electron recoils

Target Type	Examples	E_{th}	m_χ threshold	Status	Timescale
Noble liquids	Xe, Ar, He	~ 10 eV	~ 5 MeV	Done w data; improvements possible	existing
Semi-conductors	Ge, Si	~ 1 eV	~ 200 keV	($E_{\text{th}} \sim 40$ eV SuperCDMS, DAMIC) $E_{\text{th}} \sim 1$ eV SENSEI , DEPFET R&D	~ 1 -2 years
Scintillators	GaAs, NaI, CsI, ...	~ 1 eV	~ 200 keV	R&D required	$\lesssim 5$ years
Superfluid	He	~ 1 eV	~ 1 MeV	R&D required unknown background	$\lesssim 5$ years
Super-conductor	Al	~ 1 meV	~ 1 keV	R&D required unknown background	$\sim 10 - 15$ years

arXiv:1608.08632

Application of Silicon detector

DAMIC

nucleus recoil CCD, with physics results

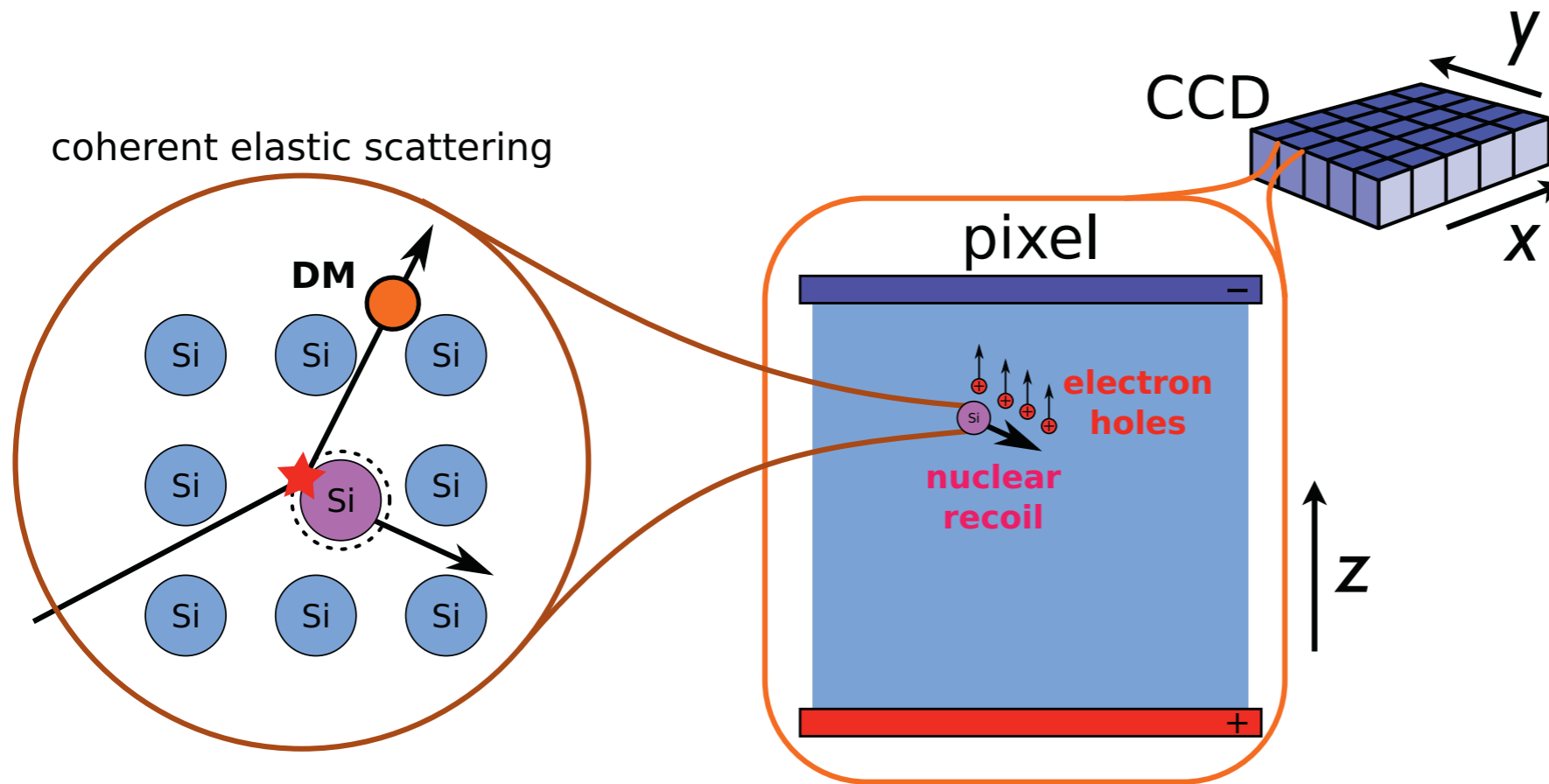

Physics Procedia 61 (2015) 21 – 33

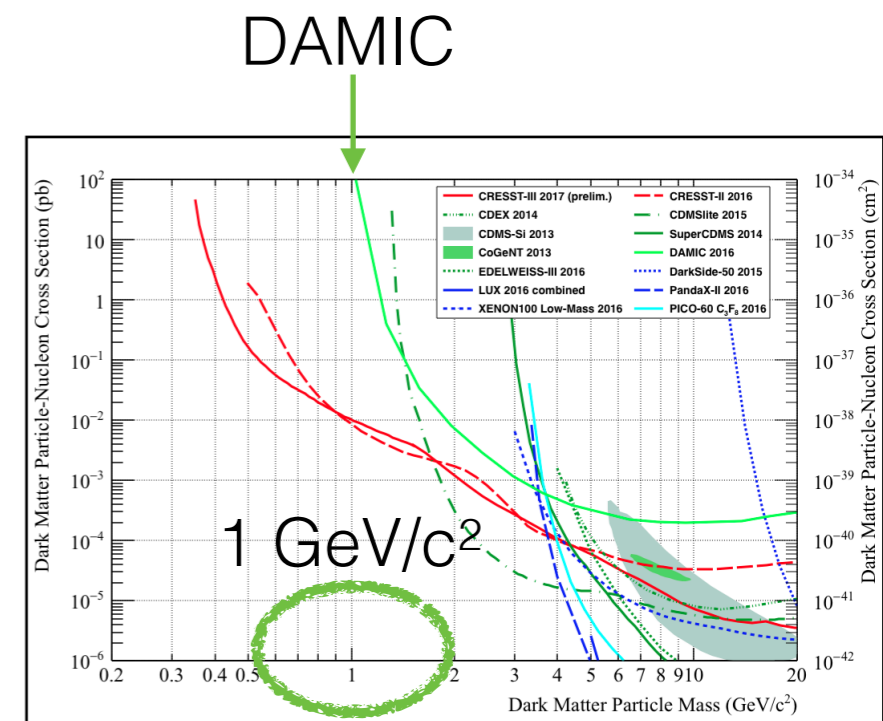

Readout noise determines threshold of $\sim 11 e^-$
(or $\sim 40 eV$)

For $O(\text{MeV})$ DM-electron scattering, required threshold : $O(e^-)$
Sub-electron noise level necessary

Skipper CCD for SENSEI

DAMIC CCD with repetitive readout

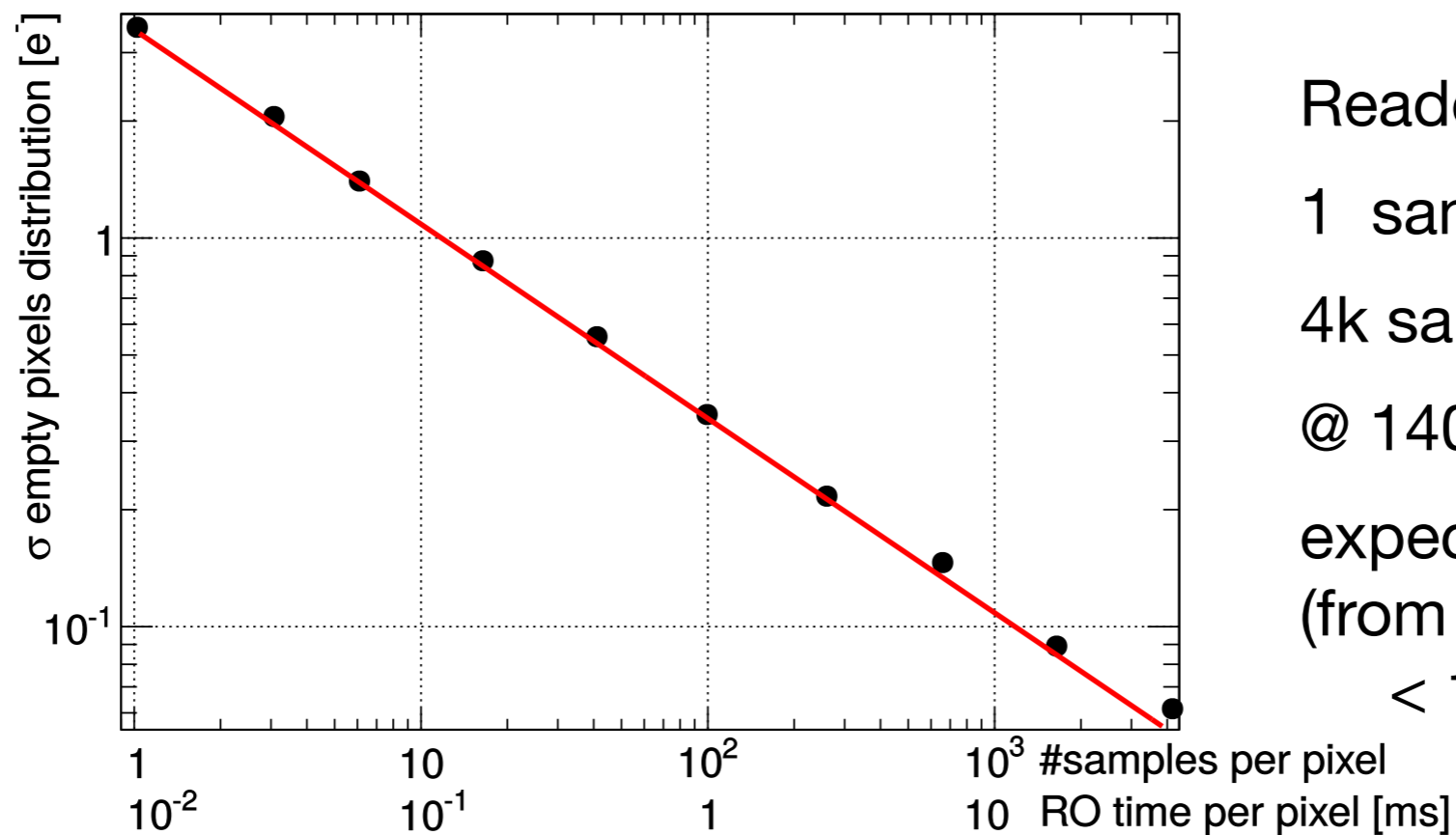
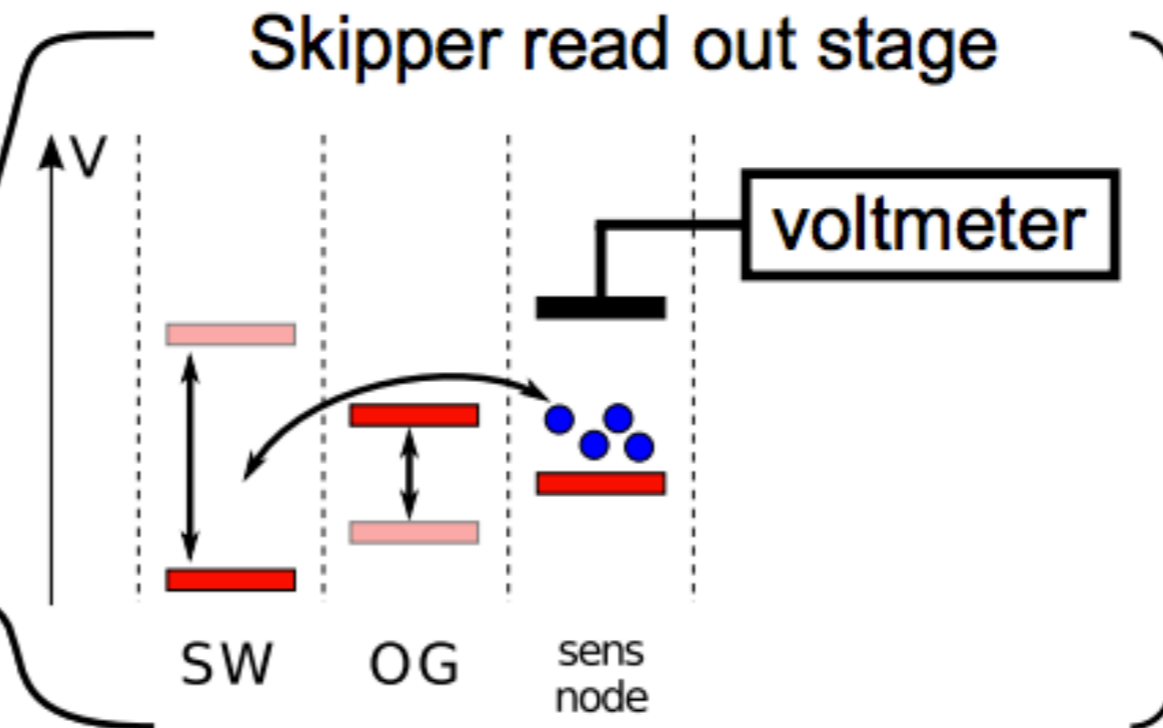
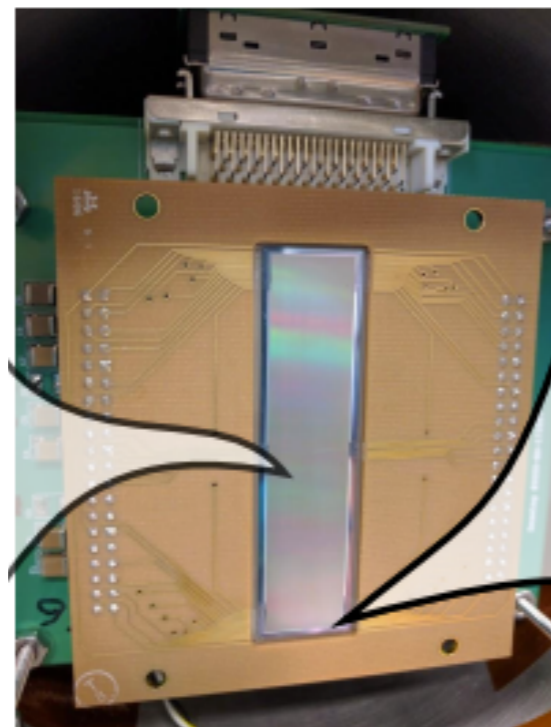

Readout noise :

1 sample : 3.55 e⁻ rms

4k samples : 0.068 e⁻ rms

@ 140 K

expected dark current
(from DAMIC CCD) :

< 10⁻³ e⁻/pix/day

SENSEI first result with “skipper” CCD

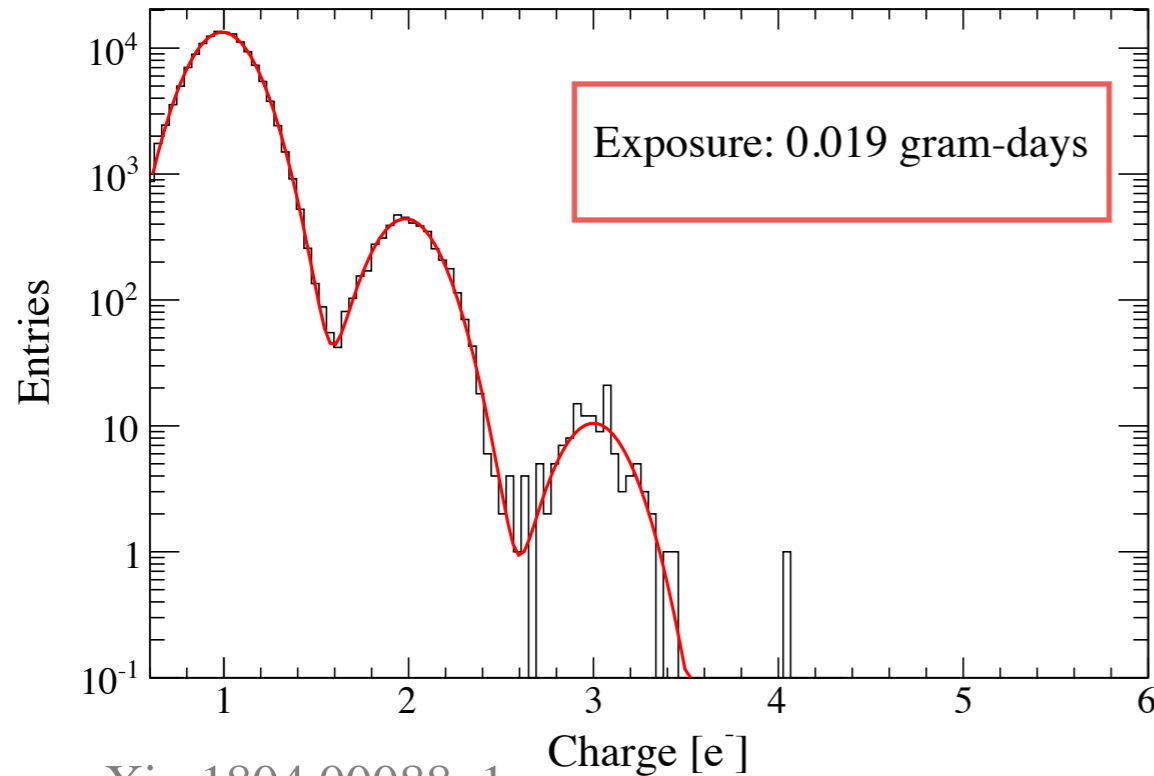

arXiv:1804.00088v1

Active mass : 0.071 grams
 427 minutes exposure (0.33 g-hr)
 above sea level 220 m
 single read noise : $\sim 4 e^-$
effective noise : $\sim 0.14 e^-$ (800 repetitions)
dark current : $\sim 1.14 e^-/\text{pixel}/\text{day}$
 assume all events DM induced
 -> conservative limit

ultralight dark photon mediator

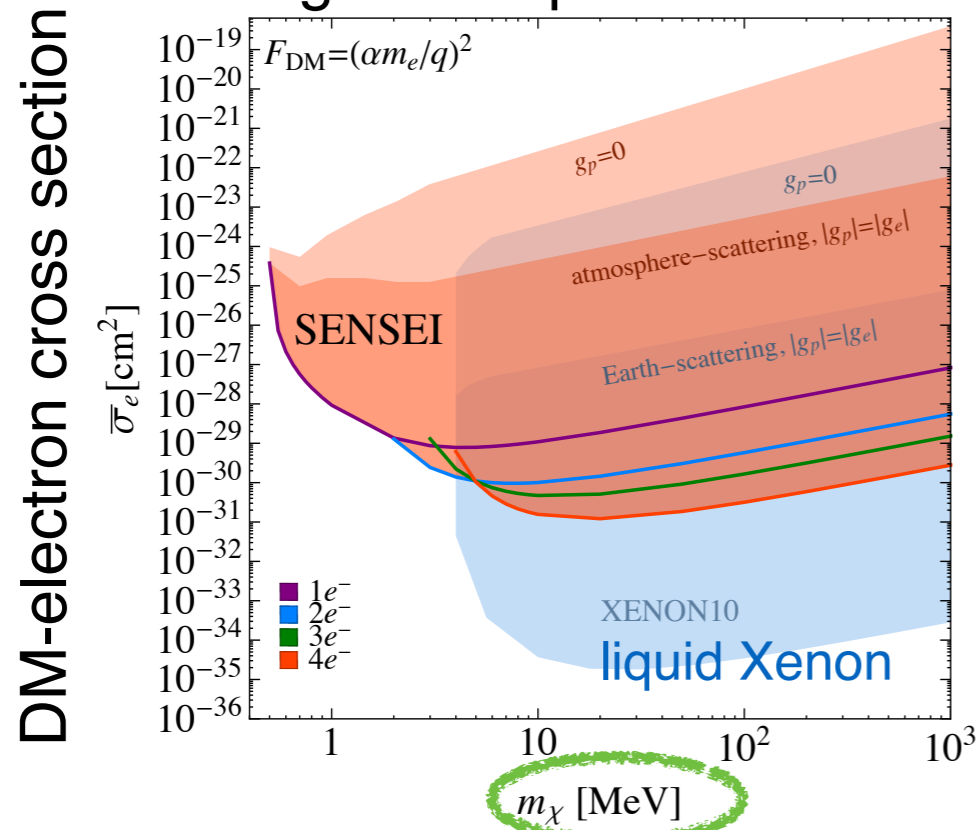

arXiv:1804.00088v1

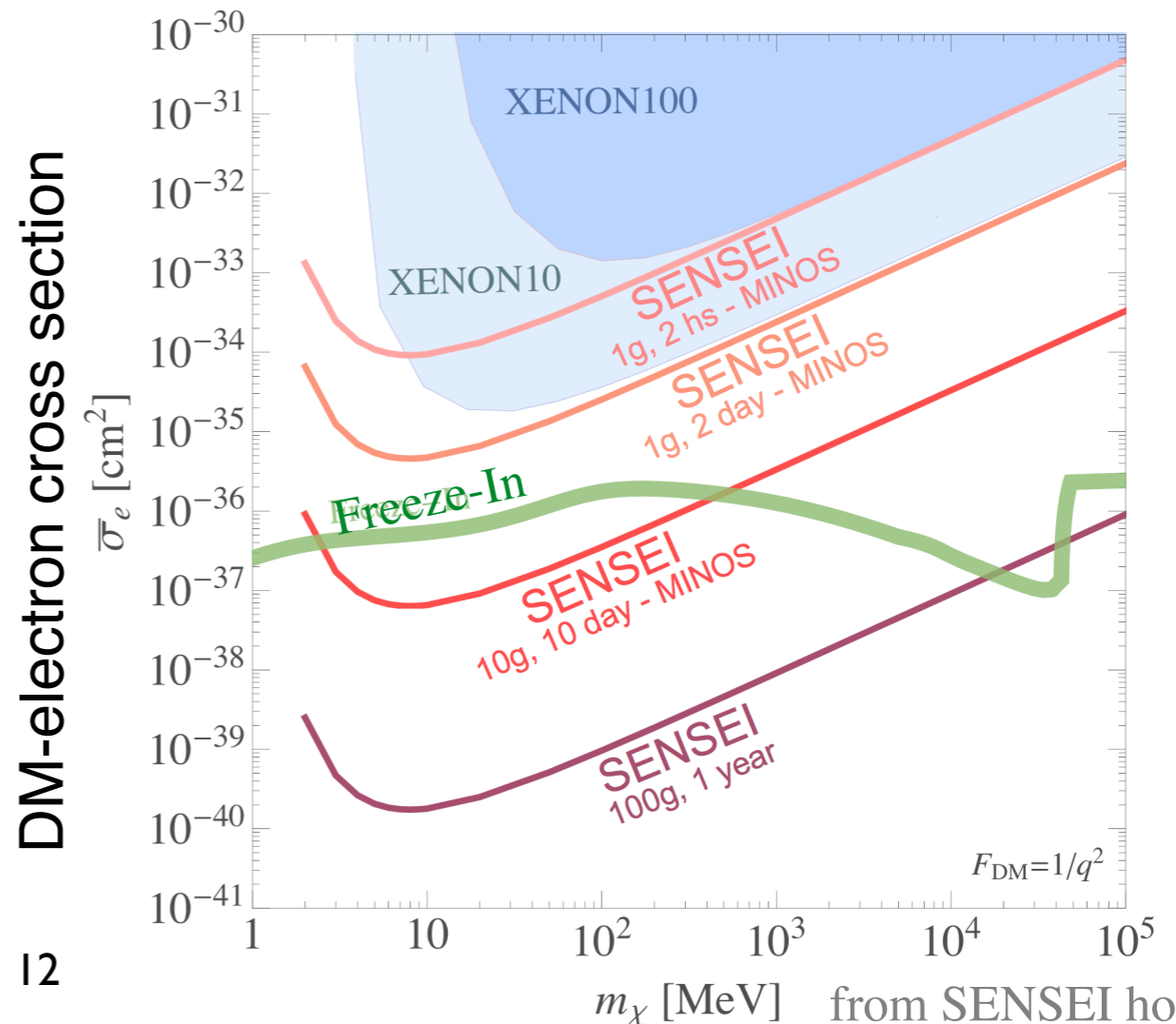

12

from SENSEI homepage

SENSEI first result with "skipper" CCD

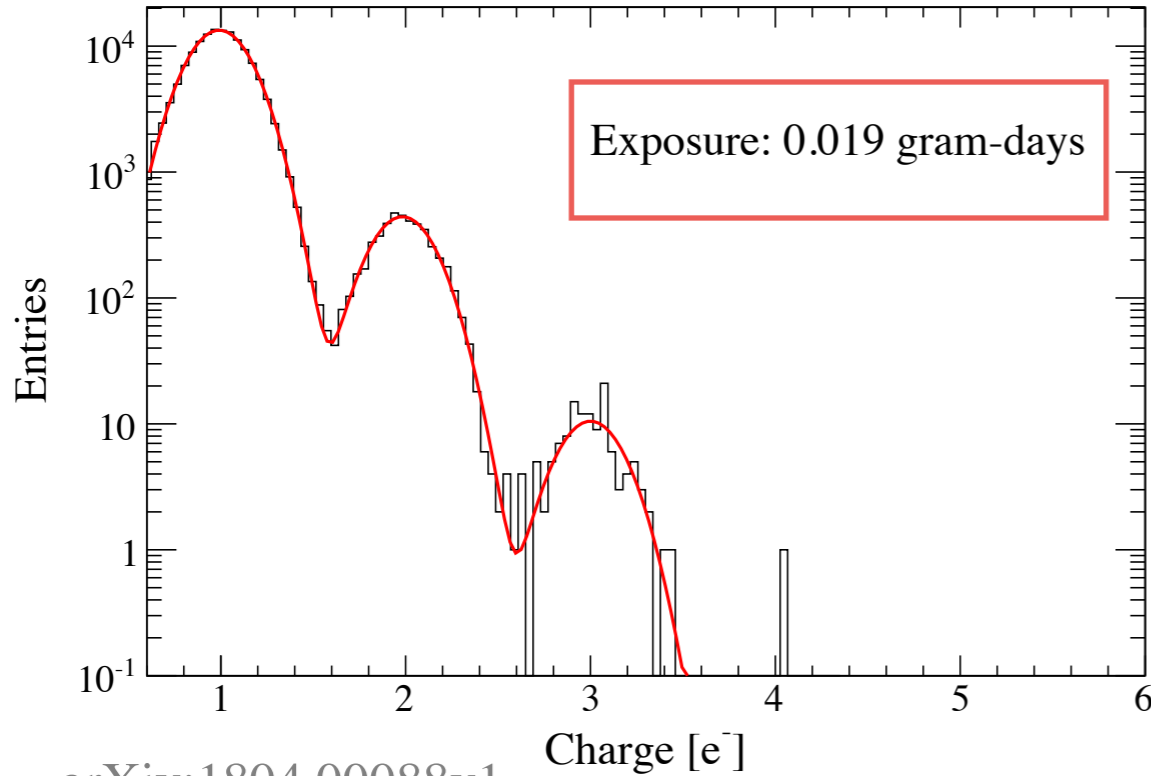

arXiv:1804.00088v1

Active mass : 0.071 grams
 427 minutes exposure (0.33 g-hr)
 above sea level 220 m
 single read noise : $\sim 4 e^-$
effective noise : $\sim 0.14 e^-$ (800 repetitions)
dark current : $\sim 1.14 e^-/\text{pixel}/\text{day}$
 assume all events DM induced

ultralight dark photon mediator

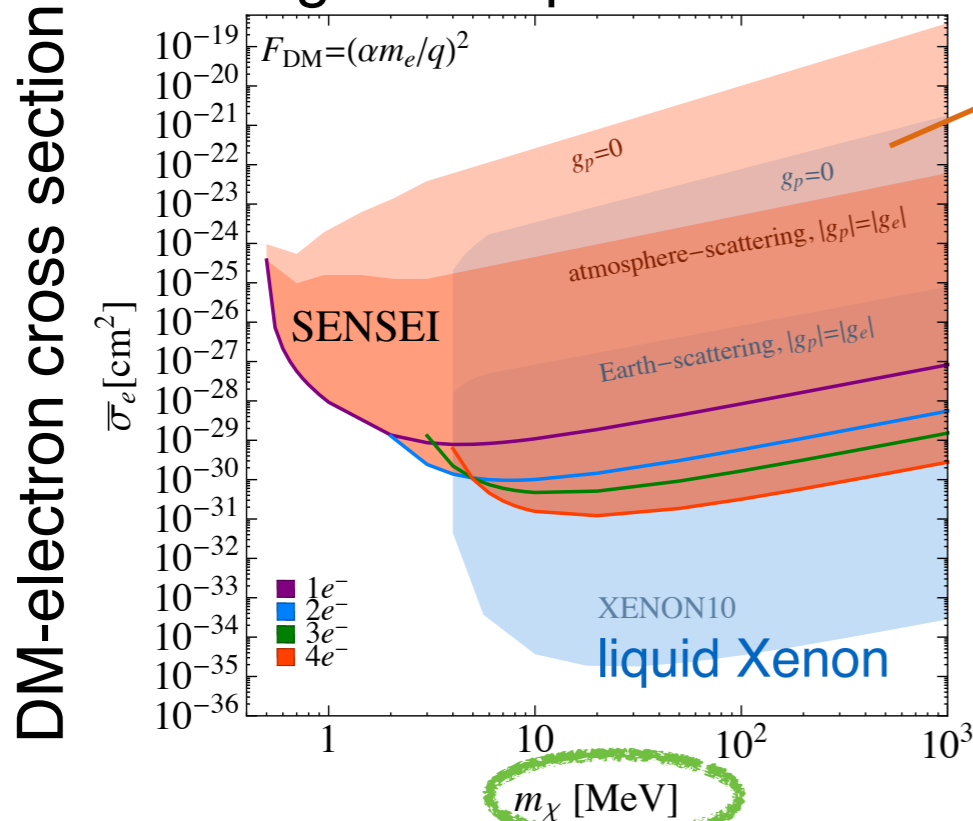

arXiv:1804.00088v1

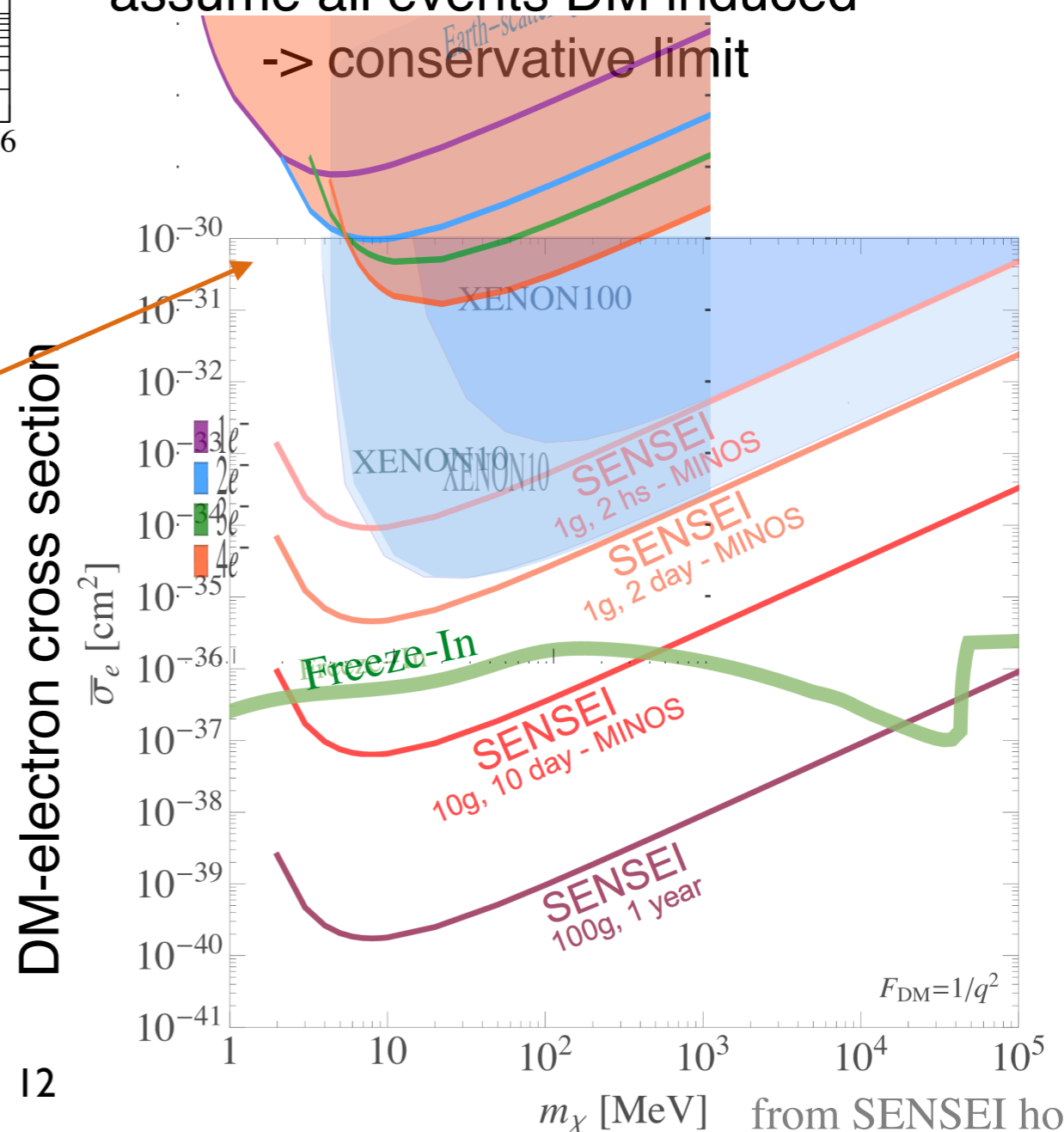

12

from SENSEI homepage

DEPFET with RNDR

RNDR : repetitive non-destructive readout

structure of a basic DEPFET cell :
a “subpixel”

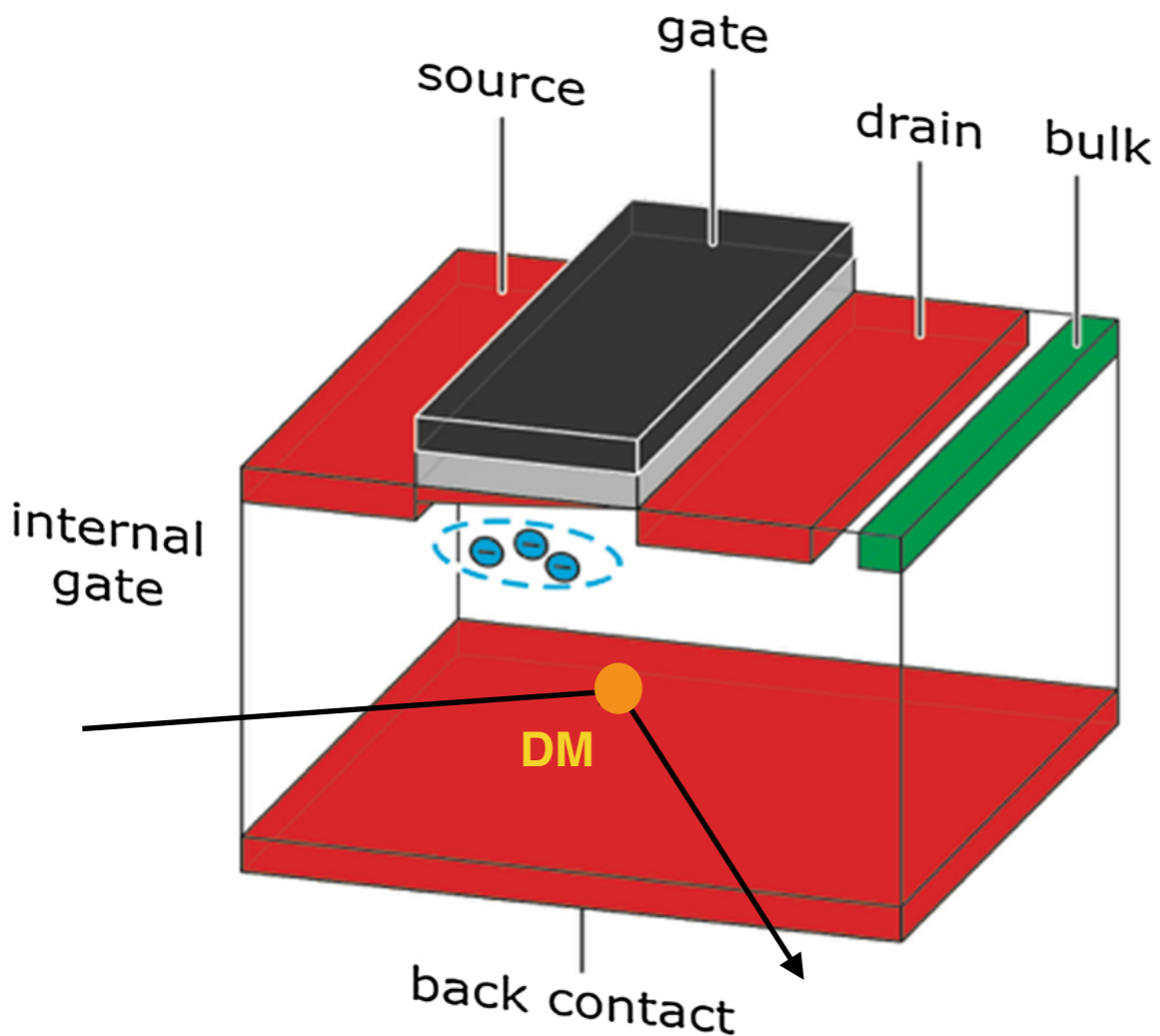

EPJ C, 77(12), 279 (2017)

fully-depleted n-Si

structure of RNDR DEPFET “super-pixel”

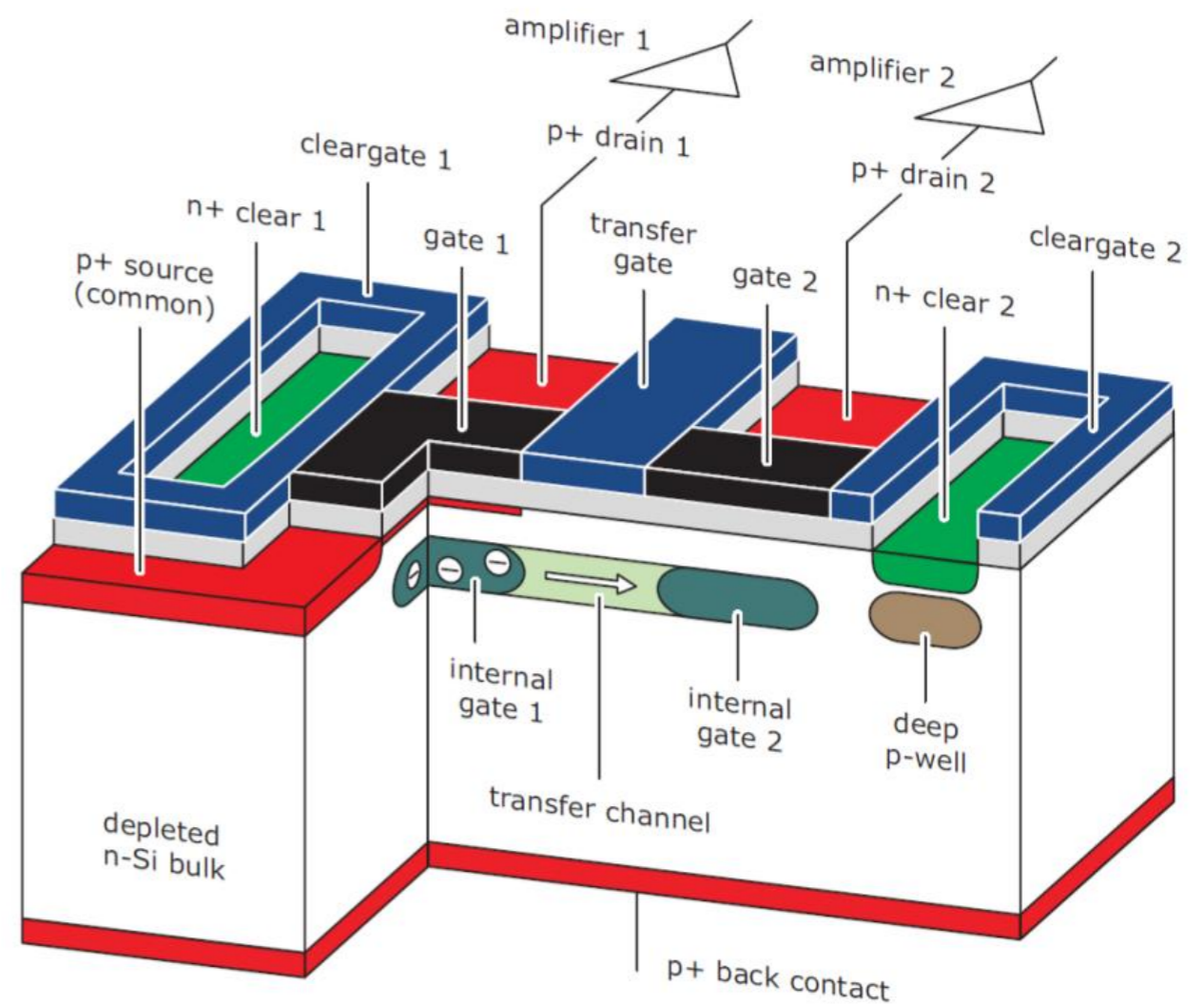

EPJ C, 77(12), 279 (2017)

RNDR

RNDR readout

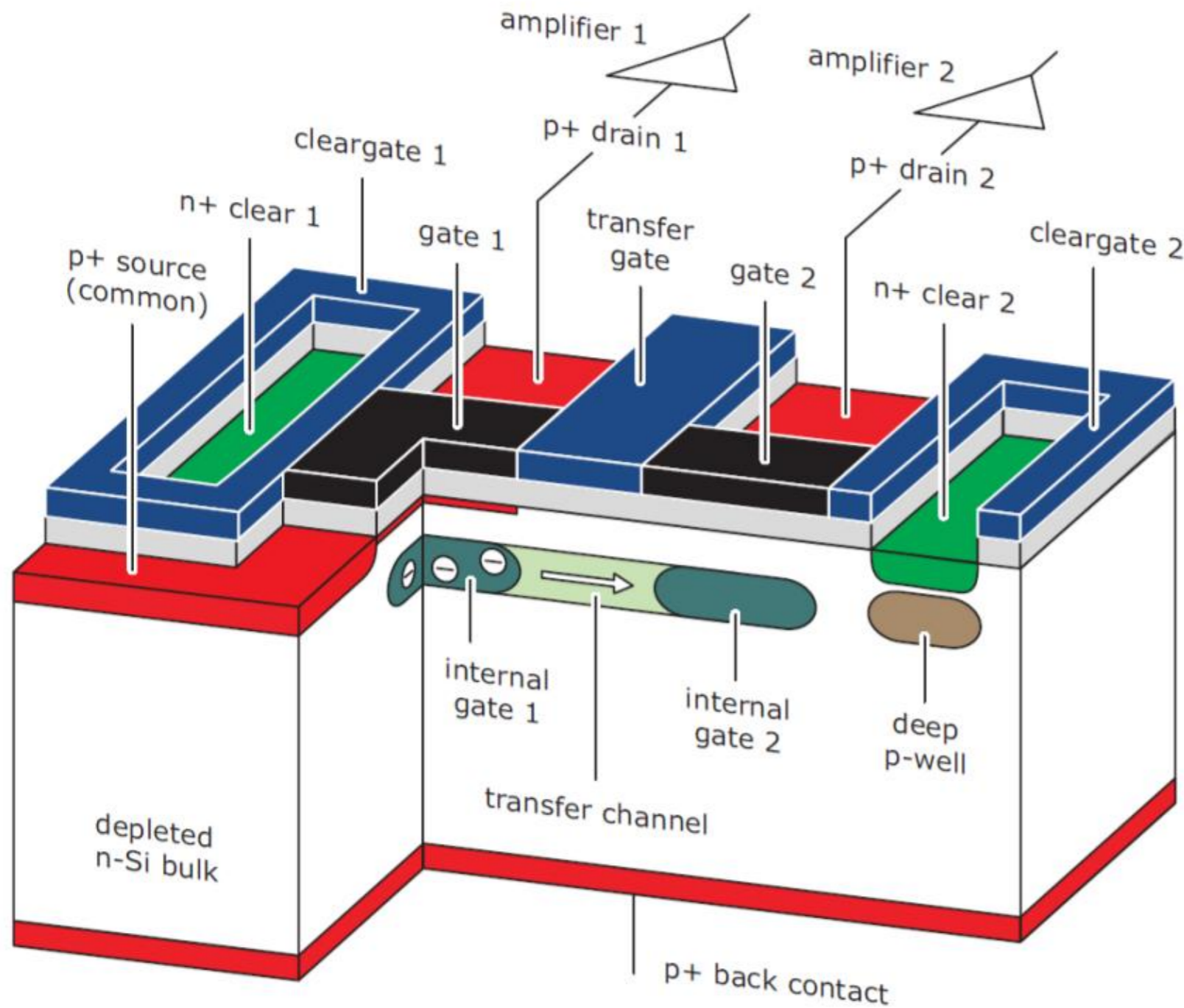

EPJ C, 77(12), 279 (2017)

read N times effective noise :

$$\sigma_{\text{eff}} = \sigma / (\sqrt{N})$$

RNDR

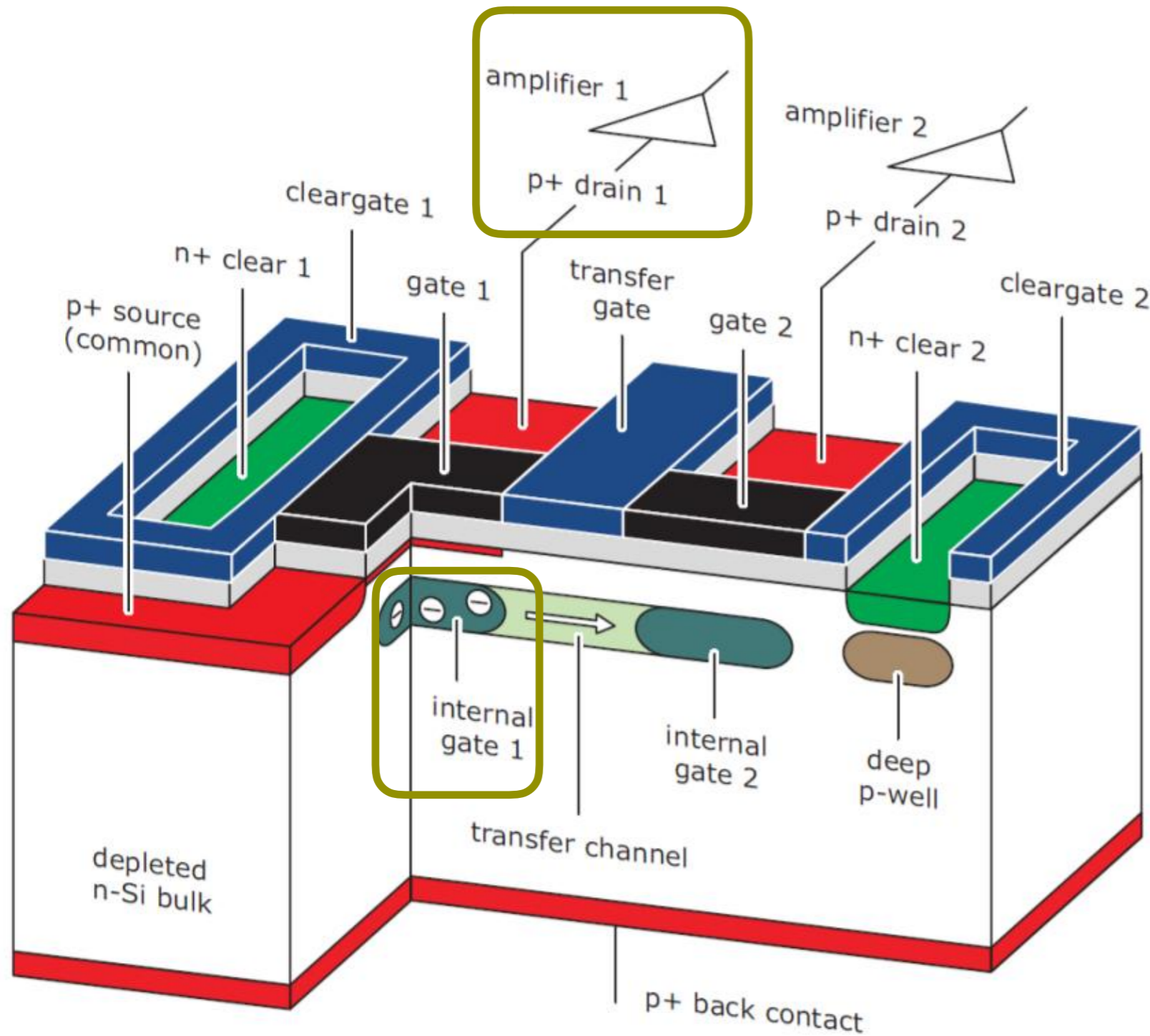

RNDR readout

read **1** : noise σ

EPJ C, 77(12), 279 (2017)

read N times effective noise :

$$\sigma_{\text{eff}} = \sigma / (\sqrt{N})$$

RNDR

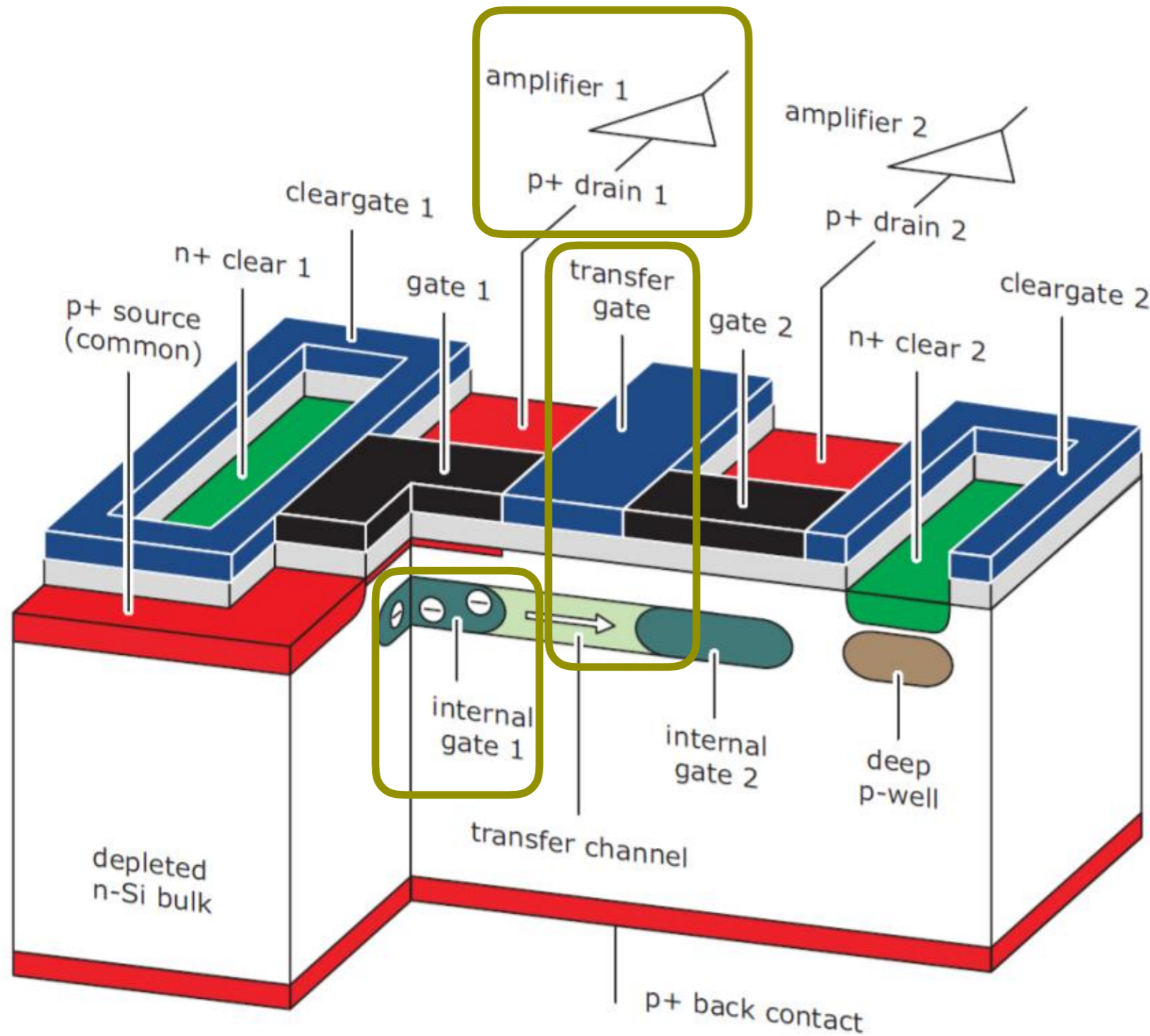

RNDR readout

read **1** : noise σ



transfer gate open

EPJ C, 77(12), 279 (2017)

read N times effective noise :

$$\sigma_{\text{eff}} = \sigma / (\sqrt{N})$$

RNDR

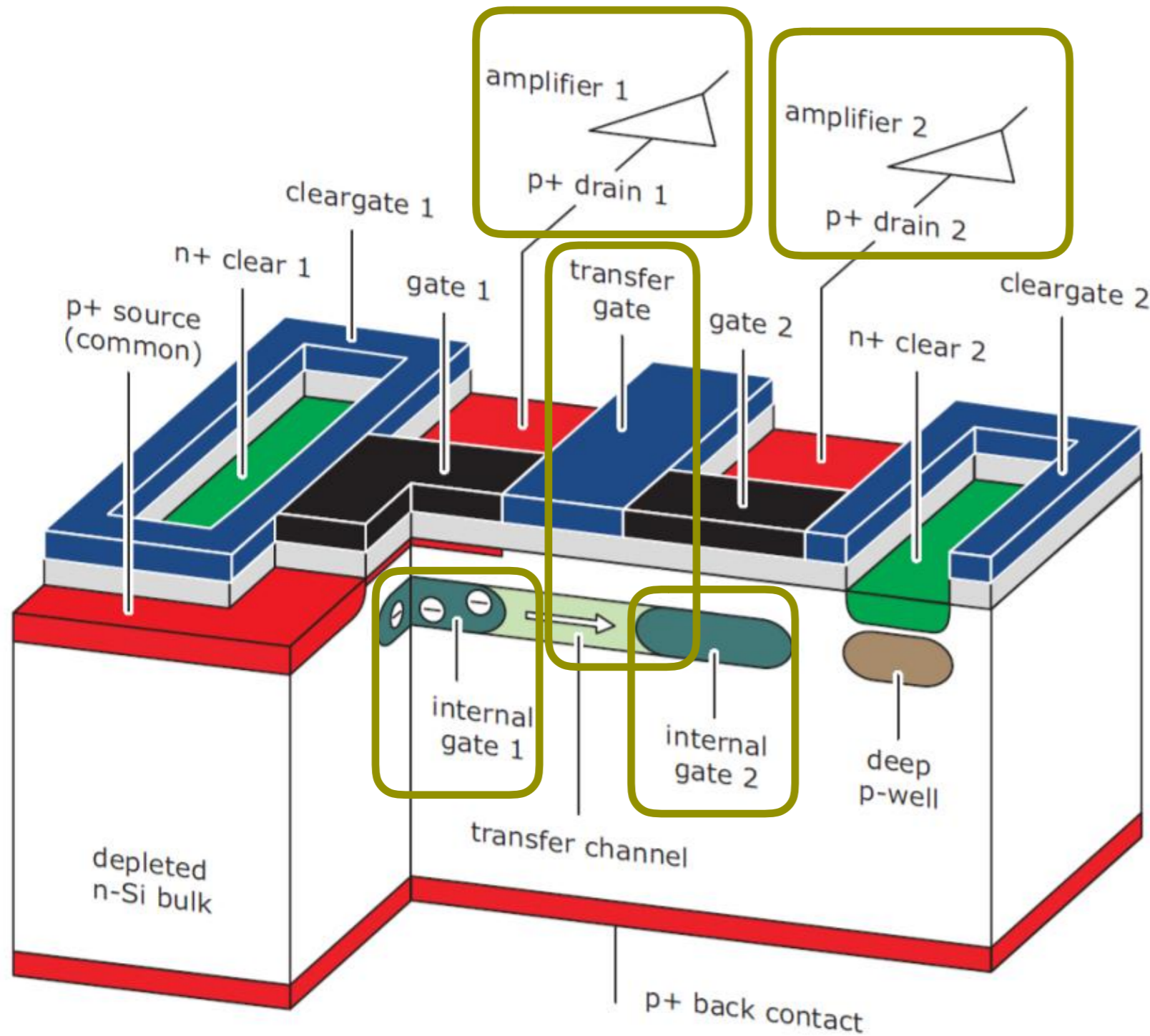

EPJ C, 77(12), 279 (2017)

RNDR readout

read **1** : noise σ



transfer gate open



read **2** : noise σ

read N times effective noise :

$$\sigma_{\text{eff}} = \sigma / (\sqrt{N})$$

RNDR

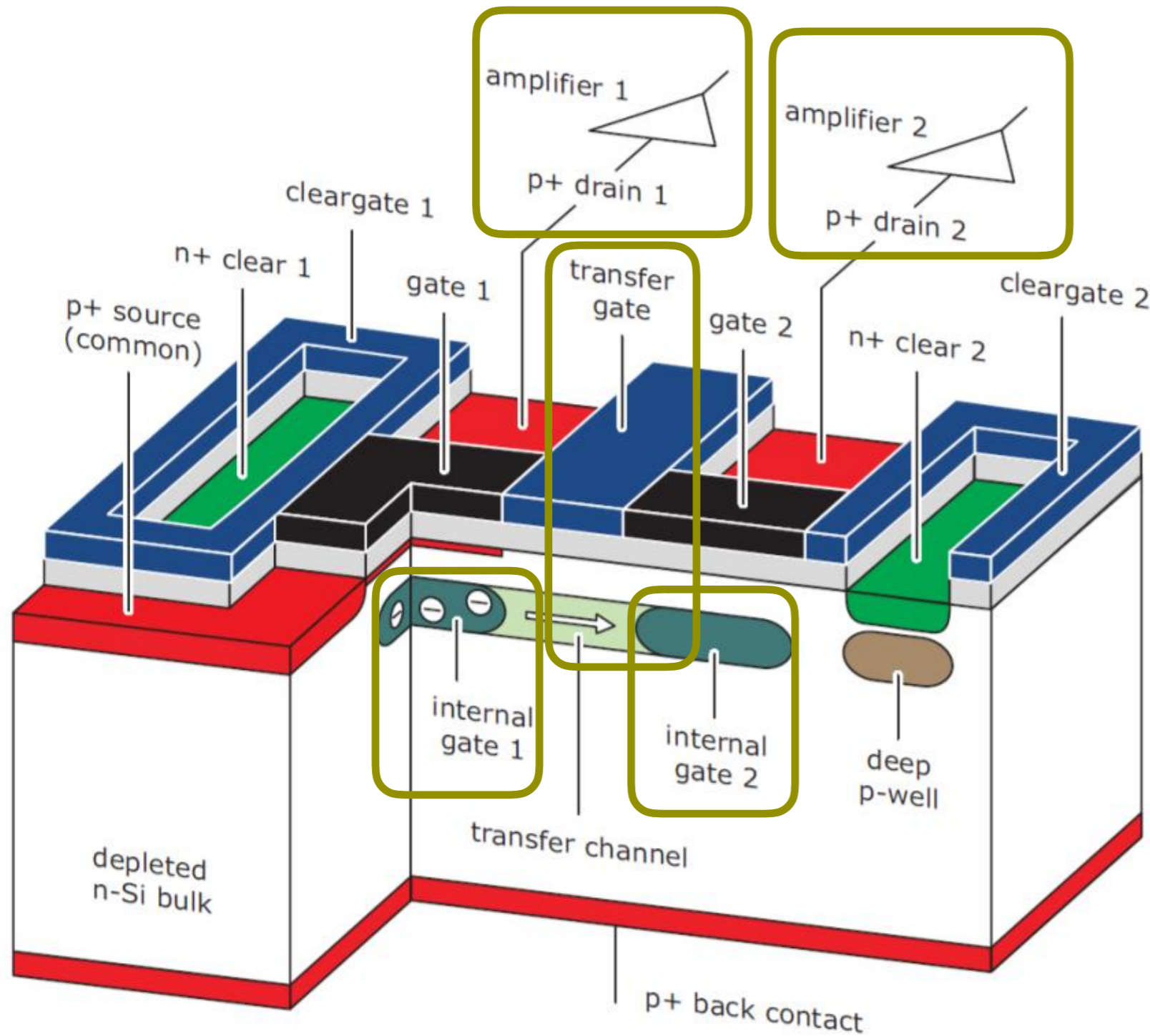

EPJ C, 77(12), 279 (2017)

RNDR readout

read **1** : noise σ



transfer gate open



read **2** : noise σ

: repeat **N** times
independent
measurements



clear charges

read N times *effective noise* :

$$\sigma_{\text{eff}} = \sigma / (\sqrt{N})$$

DEPFET RNDR single pixel performance

confirmed the $1/\sqrt{N}$ decrease of σ_{eff}

minimal noise level limited by leakage current at 230 K (-40 °C)

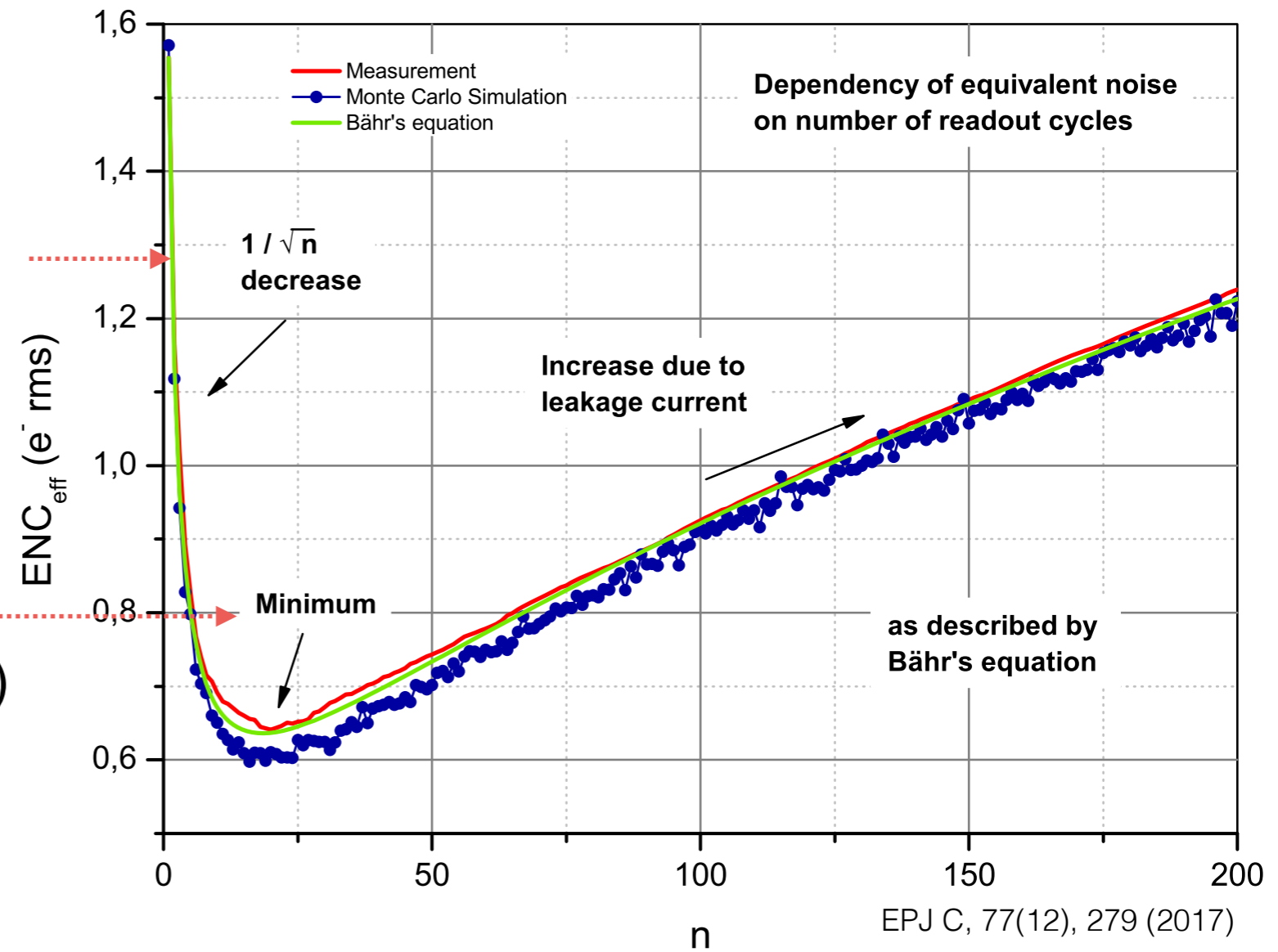

DEPFET RNDR single pixel performance

confirmed the $1/\sqrt{N}$ decrease of σ_{eff}

minimal noise level limited by leakage current at 230 K (-40 °C)

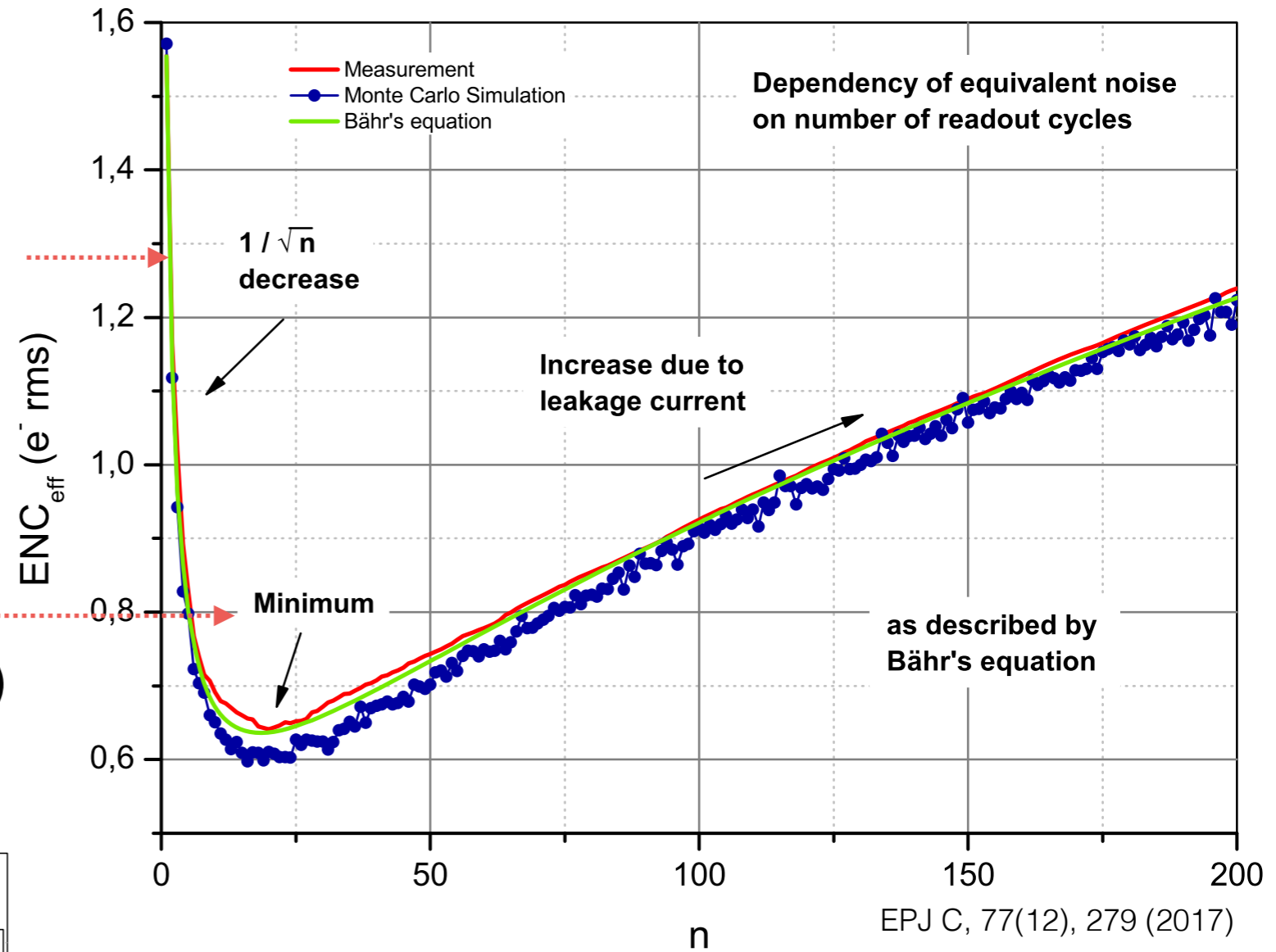

estimated temperature dependence (only DC from thermal excitation) to be testified in measurement

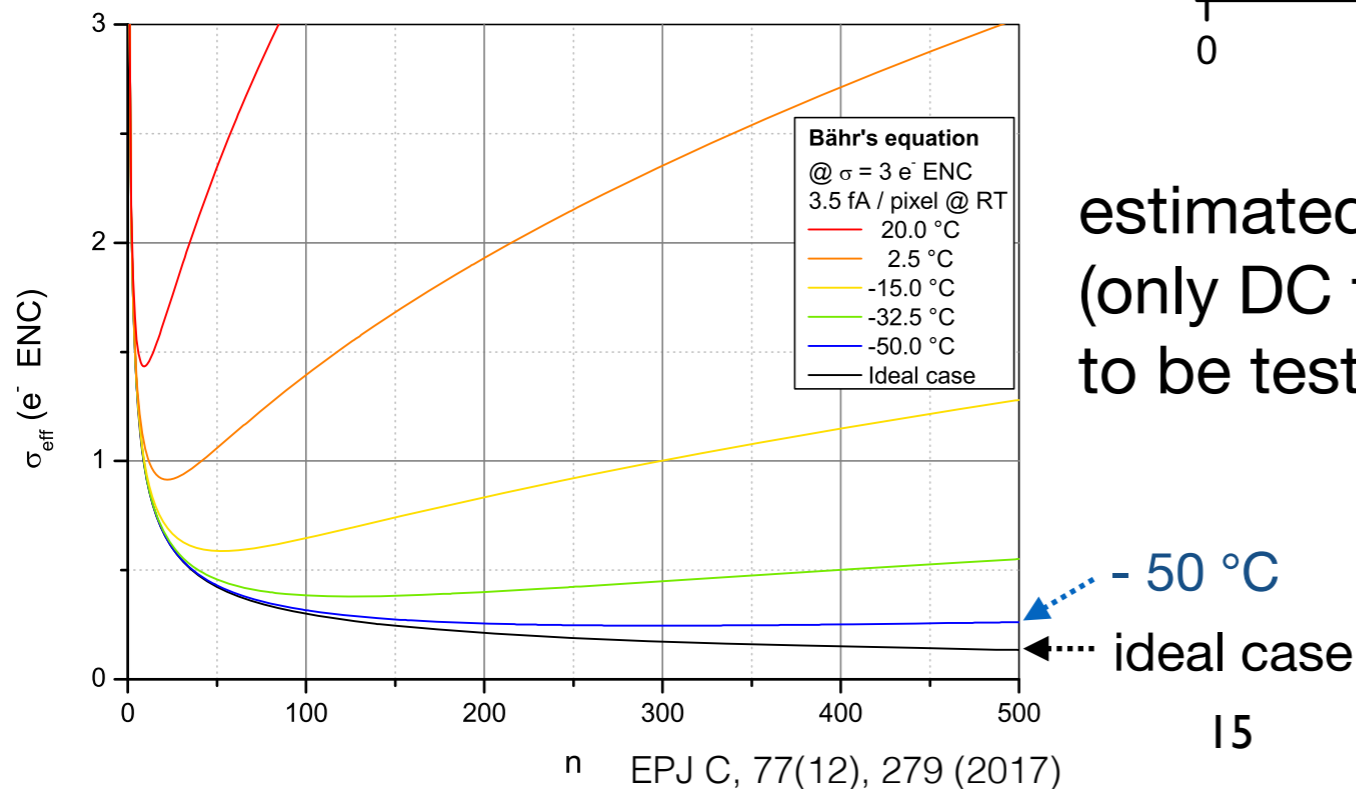

DEPFET RNDR single pixel performance

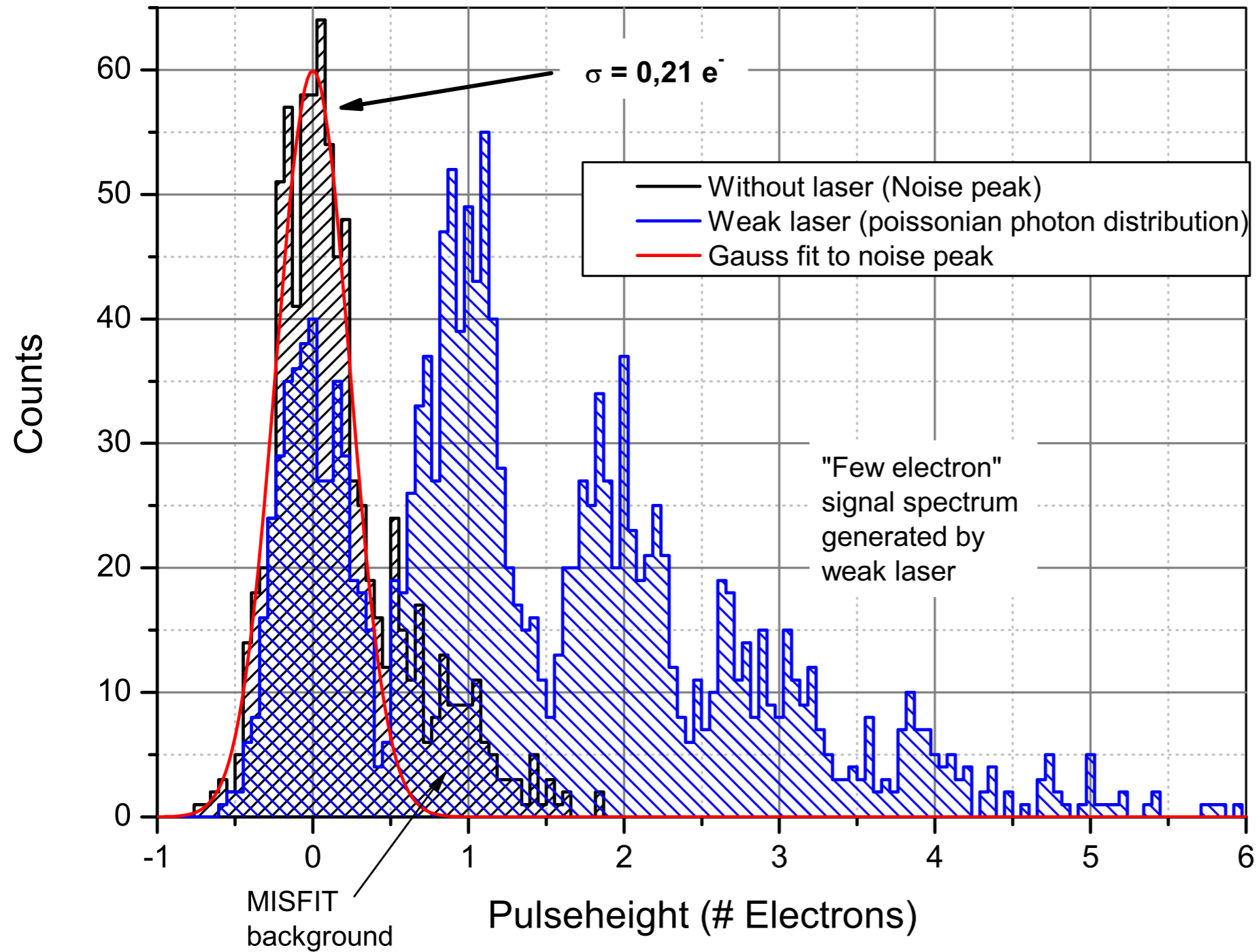

single pixel RNDR
DEPFET effective noise :
0.2 e^- RMS at 200 K

capable of distinguish
single electron charge

A comparison with skipper CCD

Type	Pixel format [μm]	prototype mass	operating temp	dark current	readout time (1 sample)	readout noise (optimal)
skipper CCD	15 x 15 x 200	0.071 g	140 K	$\leq \sim 1.14$ <u>e⁻/pix/day</u>	10 μs/pix/ amplifier	0.068 e-rms/pix
RNDR DEPFET	75 x 75 x 450	0.024 g	≈ 200 K	≤ 1 <u>e⁻/pix/day</u>	4 μs/ 64 pix	0.2 e-rms/pix

similar concepts of non-destructive readout, compatible performance;
different architecture, different systematics;
-> good complementary from experimental point of view

DANAЕ prototype test setup

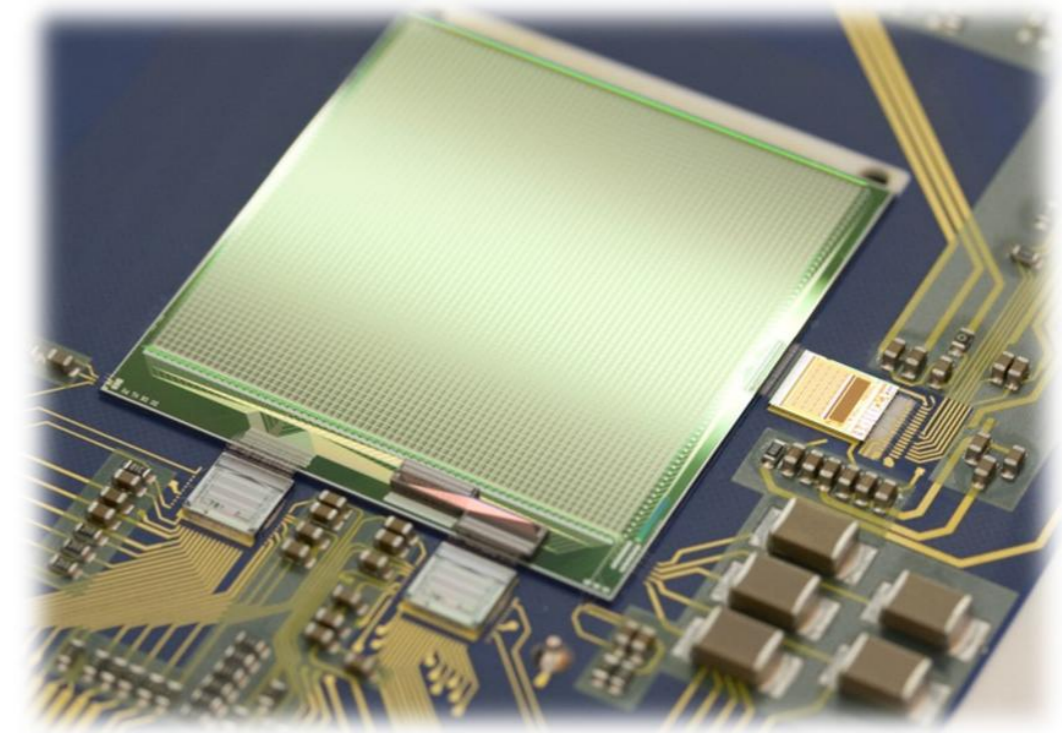
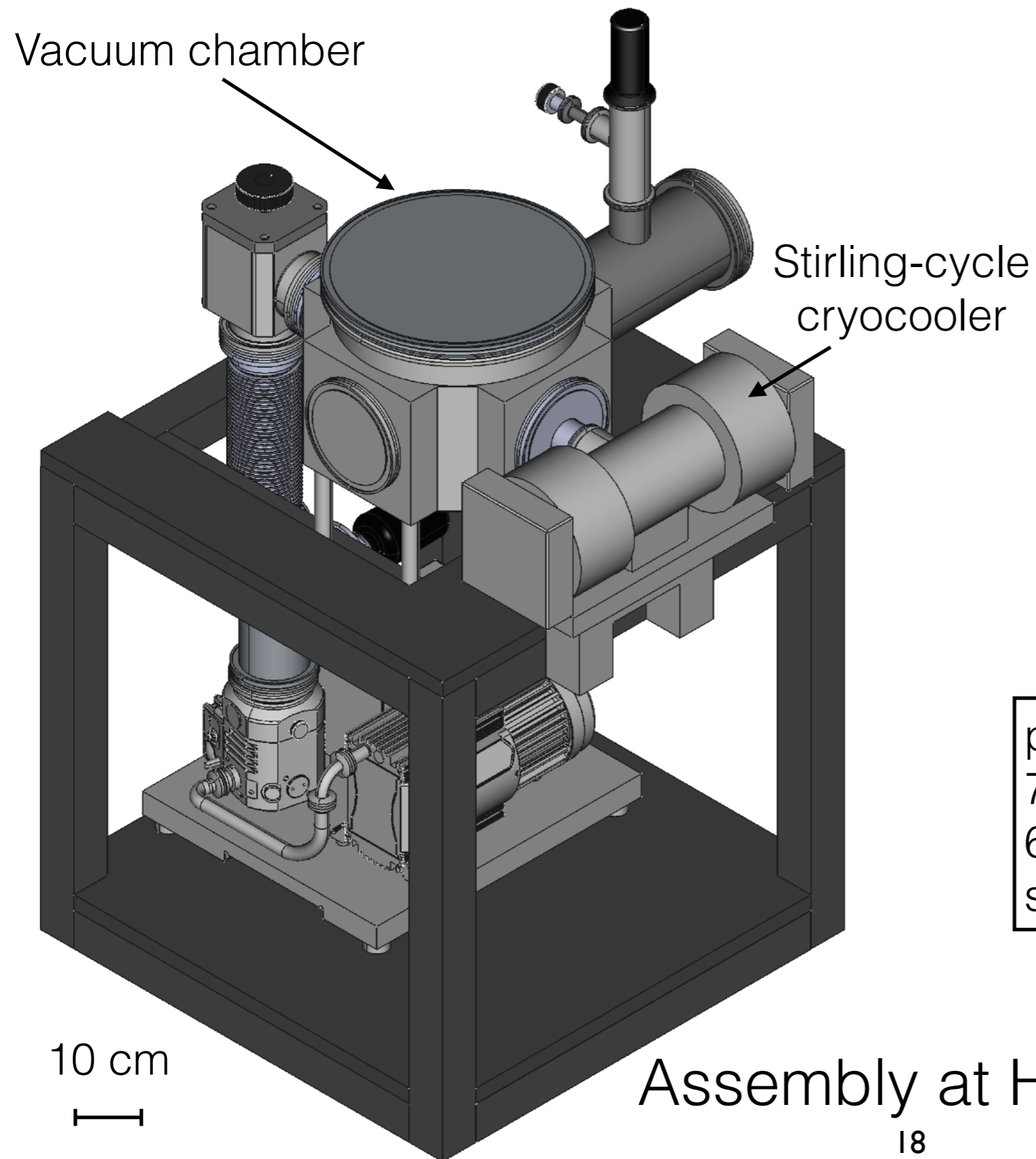

Detector prototype at HLL-MPG
courtesy of J. Treis

proto-type :
75 μm x 75 μm x 450 μm single pixel,
64 x 64 matrix
sensitive volume **0.024 g**

Setup at HLL

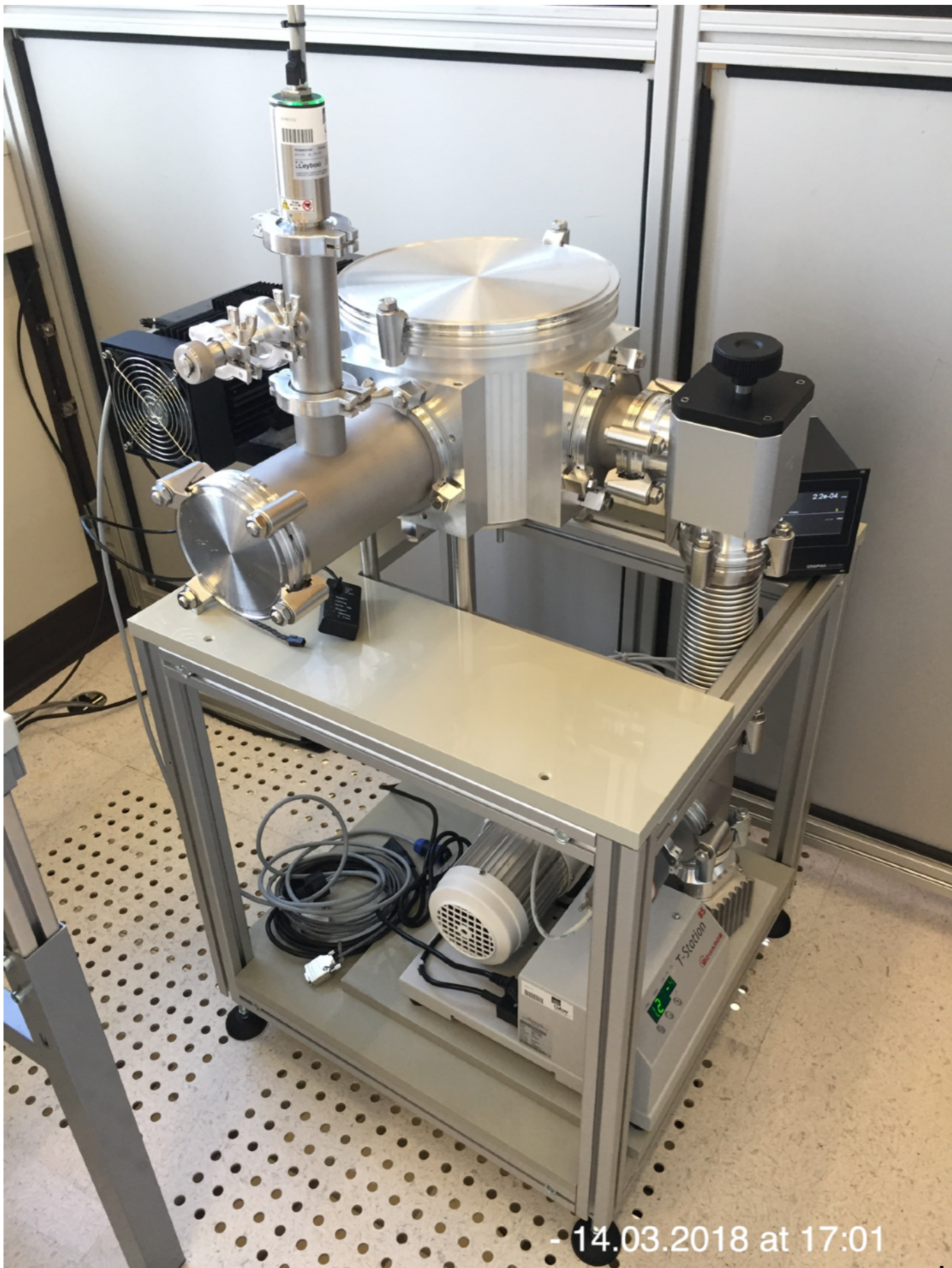

- 14.03.2018 at 17:01

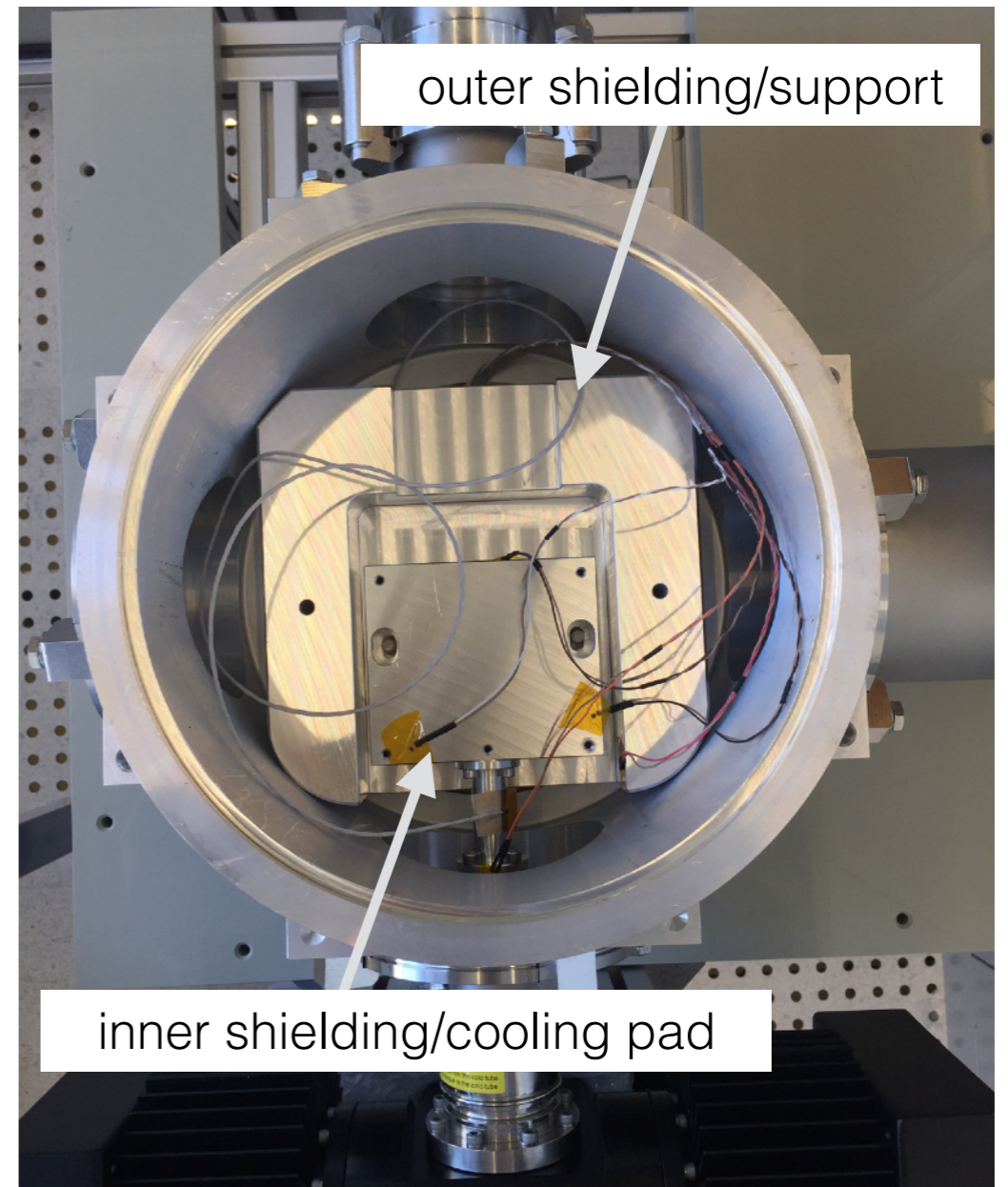

Vacuum and cooling test in March 2018
cooling pad reached 150 K

Detector control and readout electronics

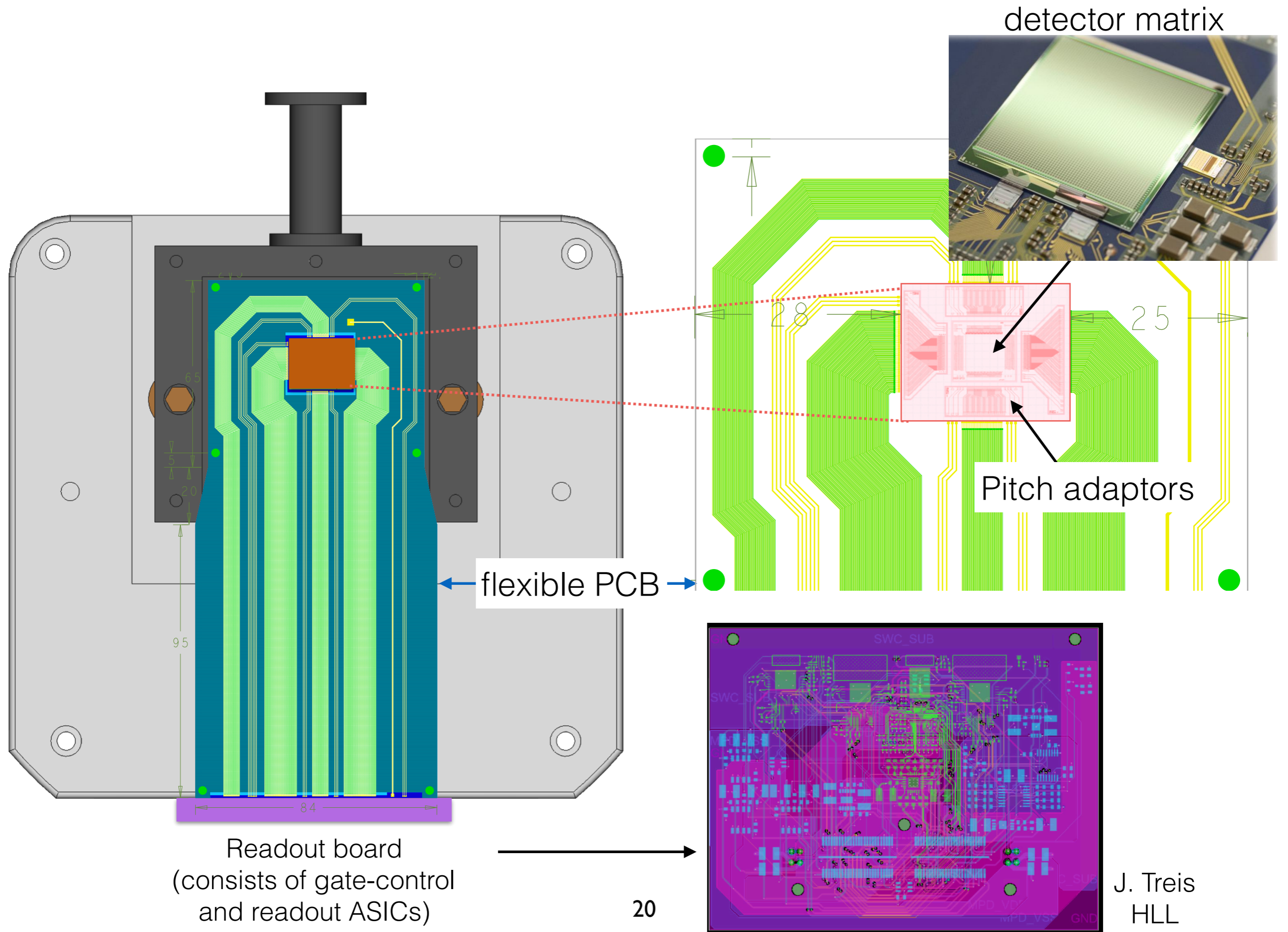

J. Treis
HLL

Image of the detector assembly

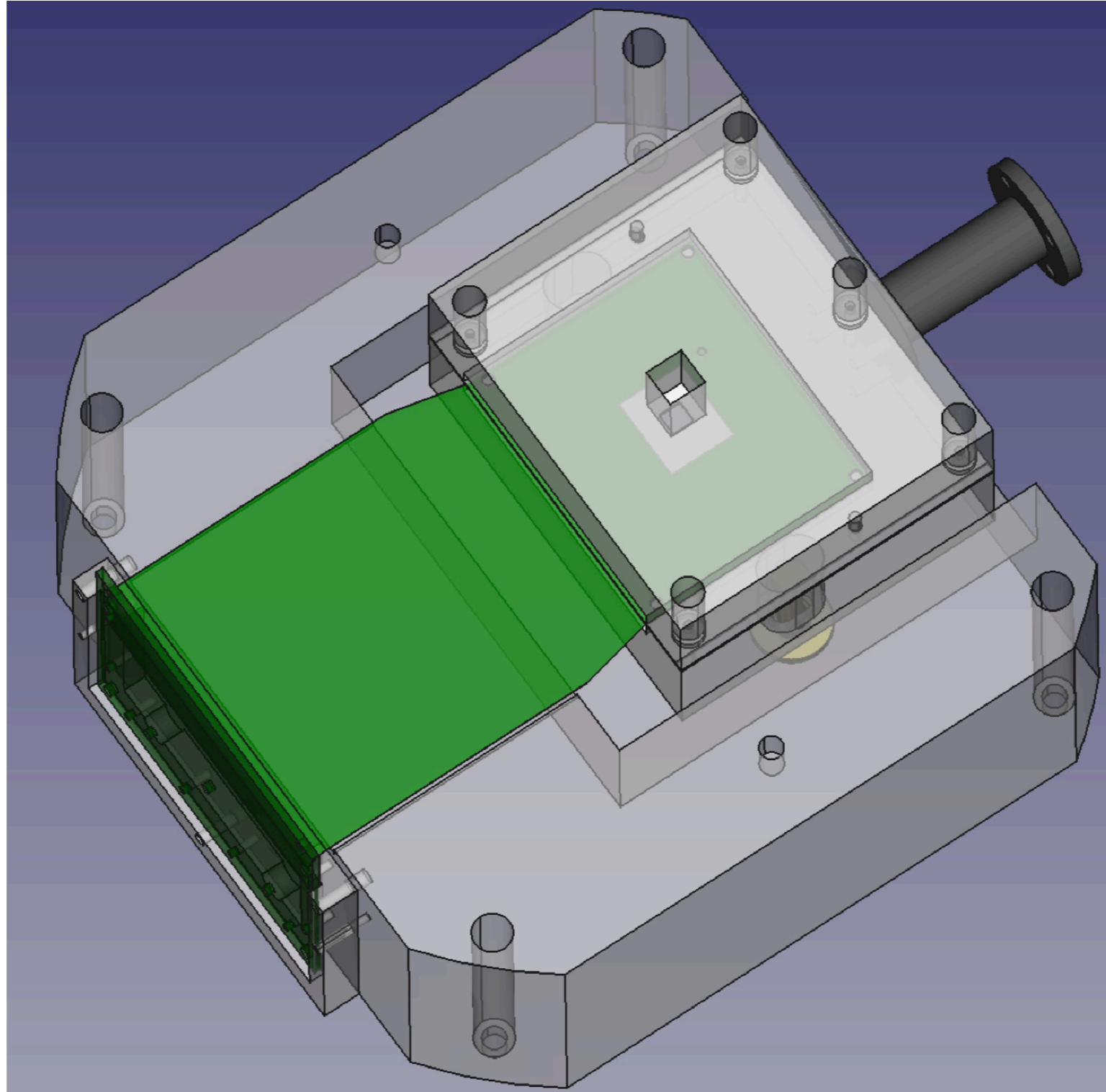

To be assembled in July-August 2018

Physics run perspective

- Expect preliminary results from the prototype setup (0.024 g sensitive volume) in late 2018
- physics run with significant result requires more matrices

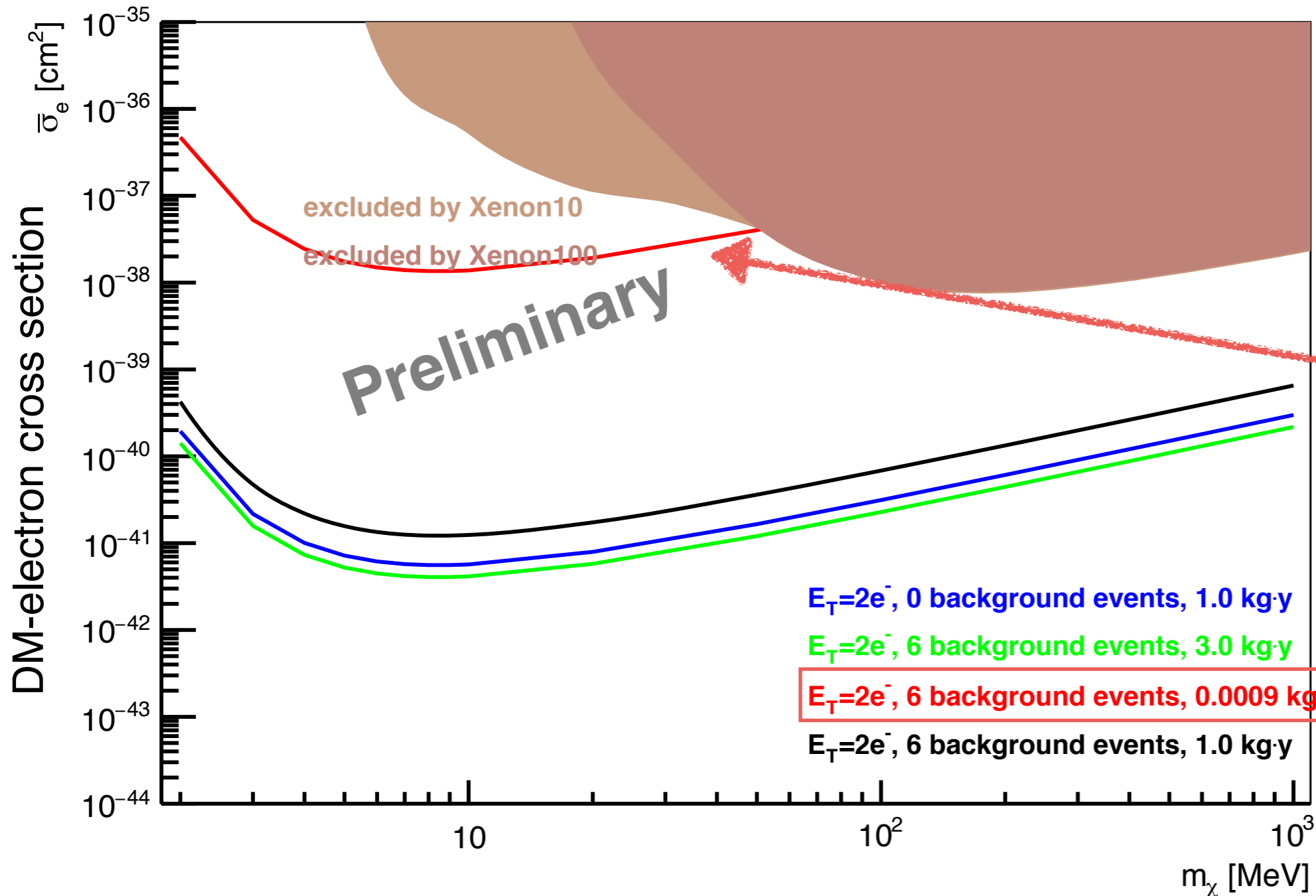

Summary

- sub e^- ENC low noise semiconductor detector capable of detecting the energy deposit from sub-GeV DM-electron recoil;
- DANAE prototype for test-of-principle measurement with 64 x 64 pixel matrix in preparation;
- one of the first generation experiments using non-destructive repetitive readout method.

DANAE (DANAË)

Direct dArk matter search using DEPFET with repetitive- Non-destructive-readout Application Experiment

OeAW funding for detector technology



“Danae” by G. Klimt

Collaboration

A. Bähr ^A, J. Ninkovic ^A, J. Treis ^A,
H. Kluck ^{B,C}, J. Schieck ^{B,C}, H. Shi ^B,



Max-Planck-Gesellschaft Halbleiterlabor, Germany ^A,

Institut für Hochenergiephysik der Österreichischen Akademie der Wissenschaften, Vienna, Austria ^B,

Atominstytut, Technische Universität Wien, Vienna, Austria ^C

Expected 1day exposure compared to SENSEI

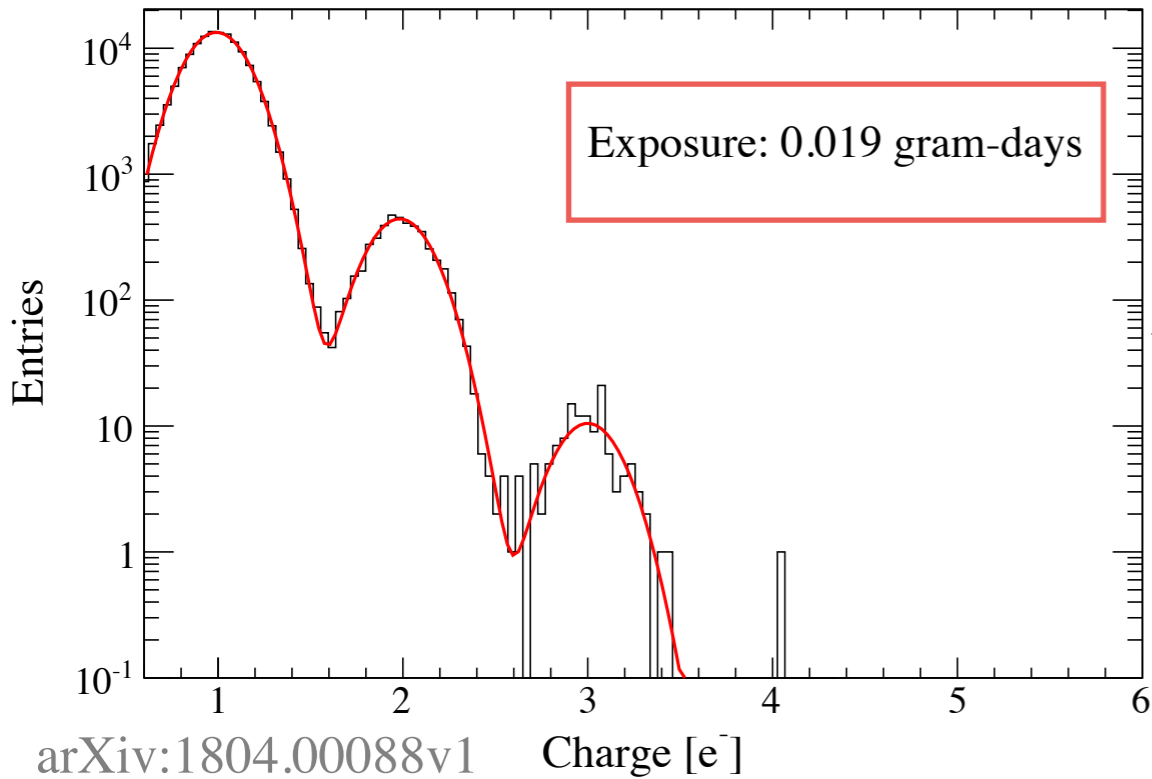

SENSEI prototype physics run

DANAЕ prototype 24 mg one-day exposure zero background expected reach (Preliminary)

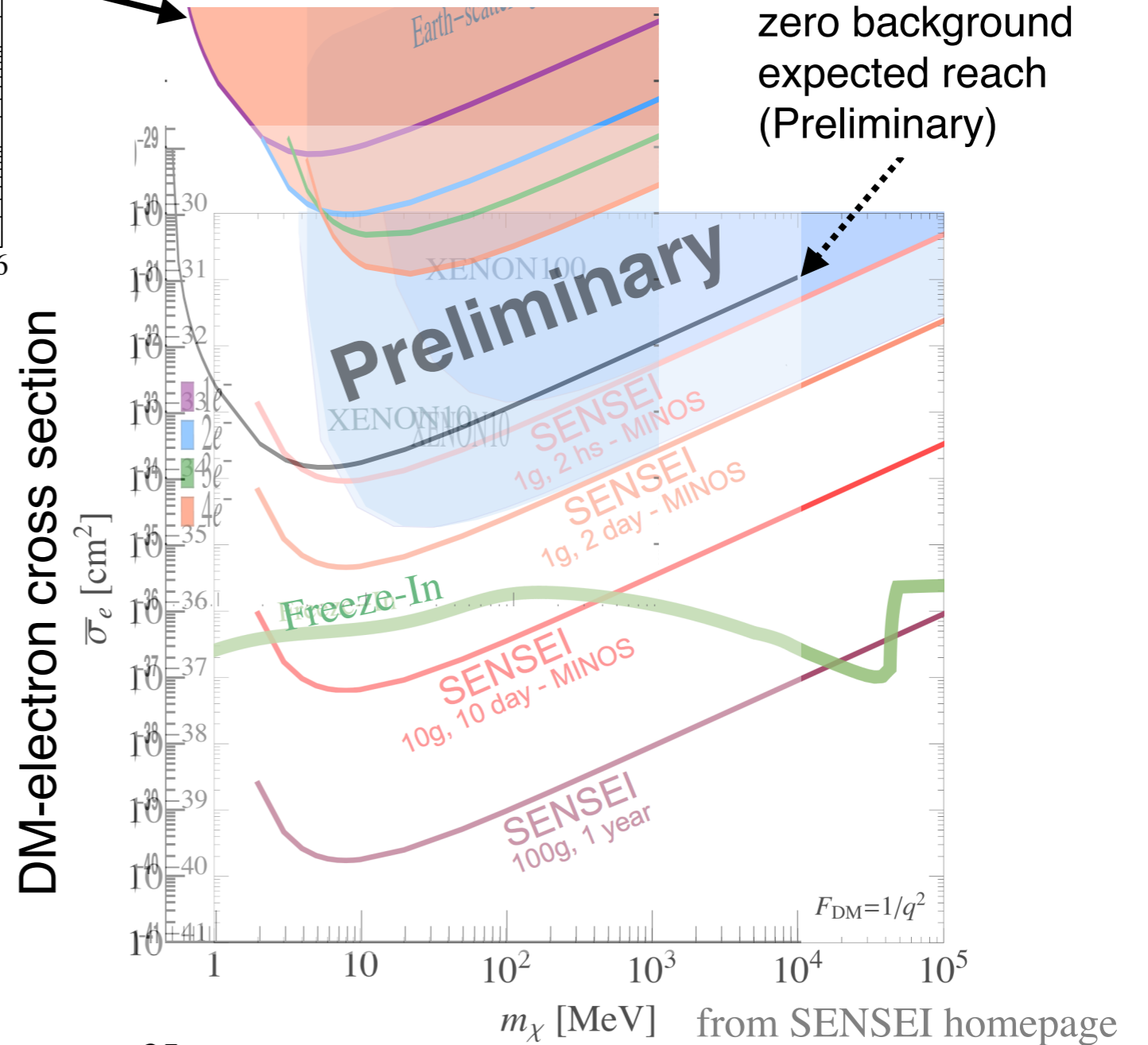

DEPFET matrix control & readout electronics

Detector matrix

Front-end ASICS for the 64x64 matrix
with interface to Switcher-S, VERITAS

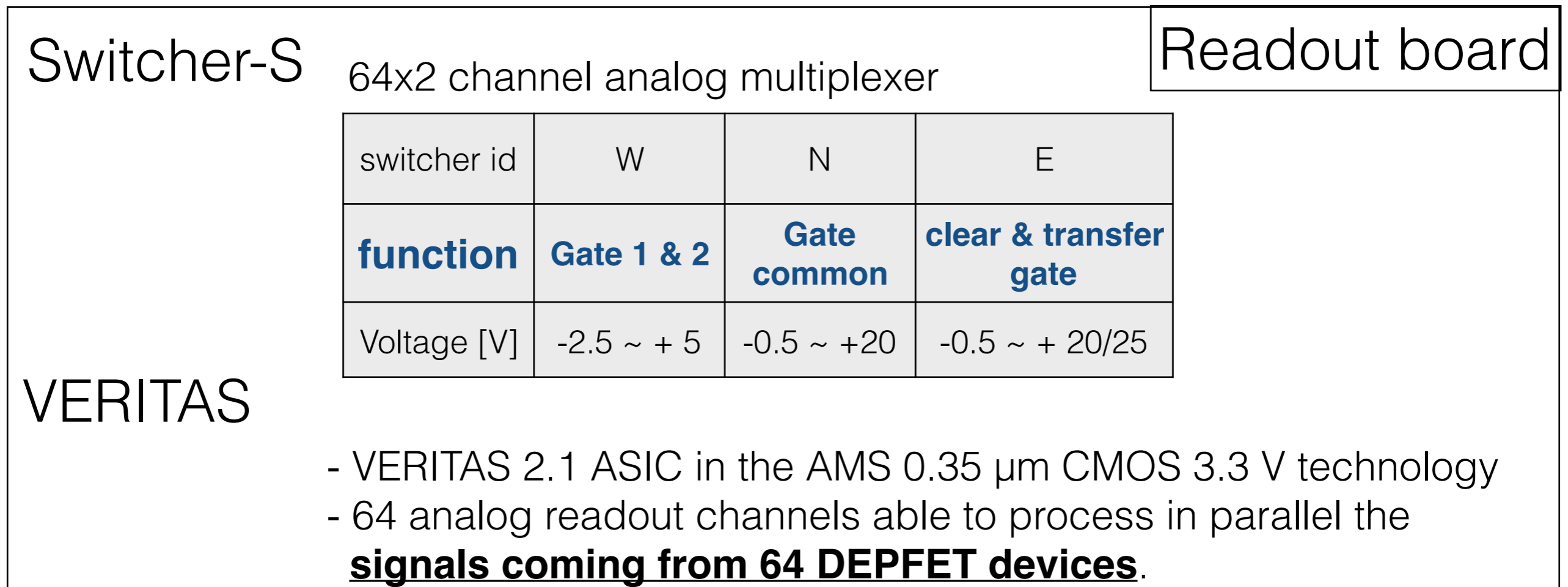

ADC

FADC type digitizer

DEPFET CDS circle



Detector Structures – Matrix Devices

readout sequence

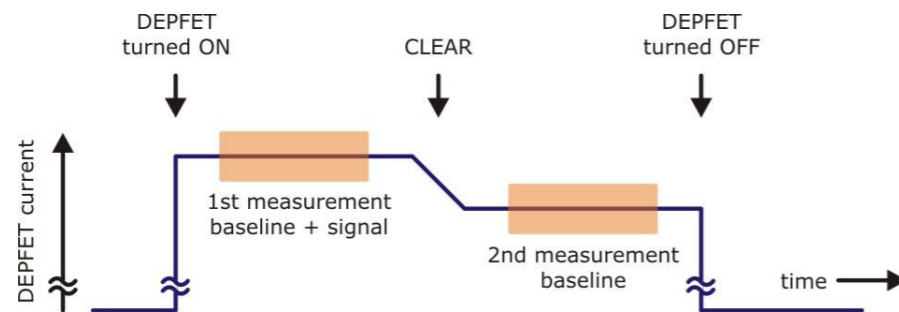

Correlated double sampling:

1st measurement: signal + baseline

clear: removal of signal charges

2nd measurement: baseline

difference = signal

complete clear is mandatory!

matrix operation

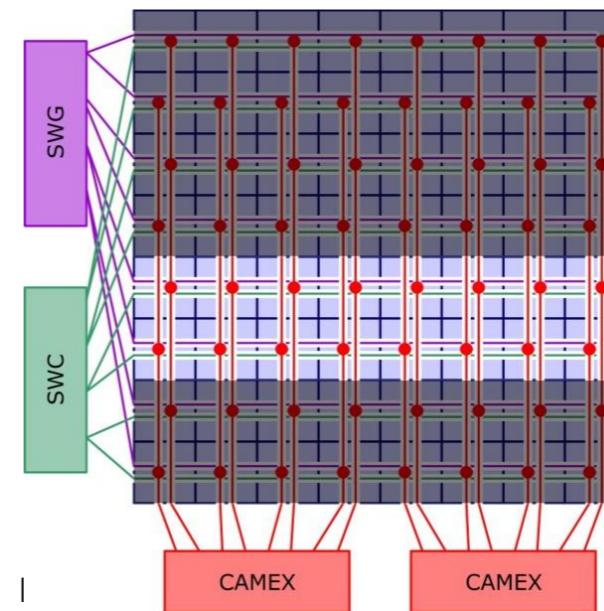

vertical signal lines

1 active row, other pixels integrating

option to speed up (1)

readout parallelisation

2 x readout channels, 2 active rows

CCD (skipper) readout

CCD: readout

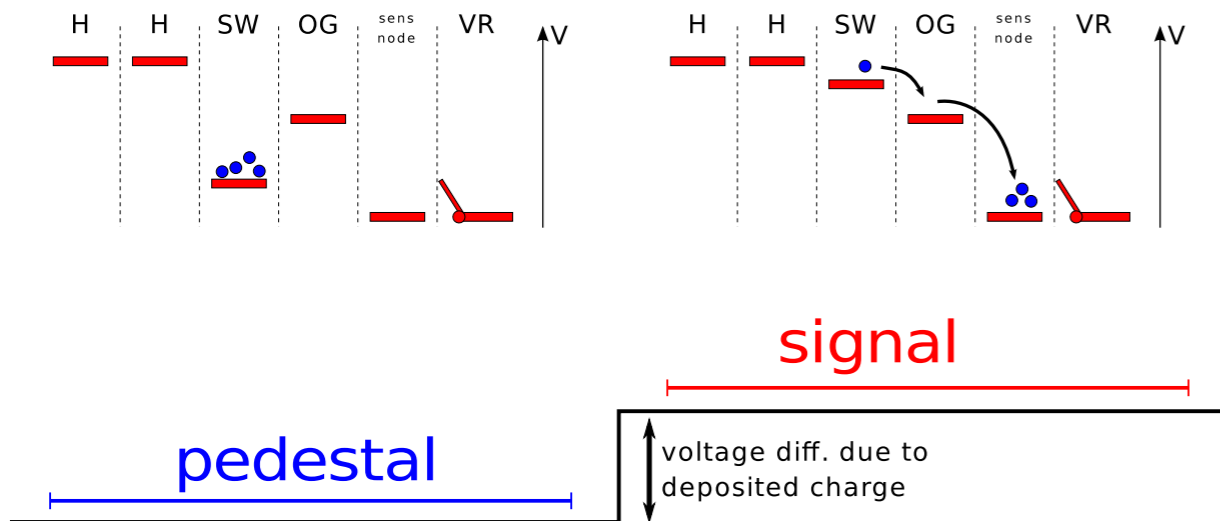

Lowering the noise: Skipper CCD

- **Main difference:** the Skipper CCD allows multiple sampling of the same pixel without corrupting the charge packet.
- The final pixel value is the average of the samples

$$\text{Pixel value} = \frac{1}{N} \sum_i^N (\text{pixel sample})_i$$

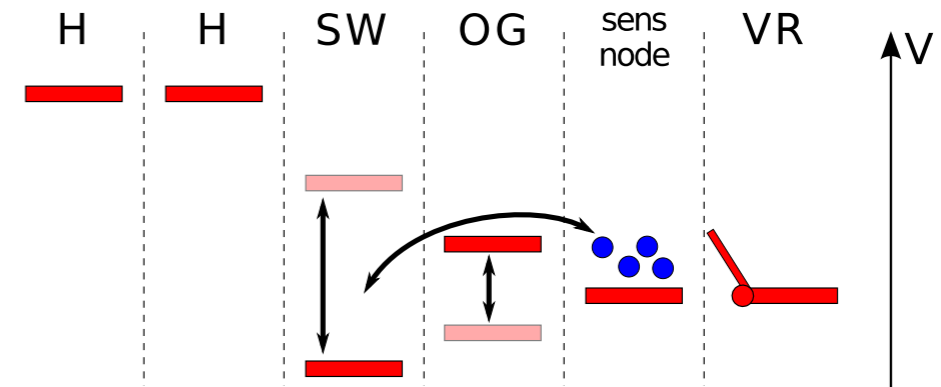

CCD: readout

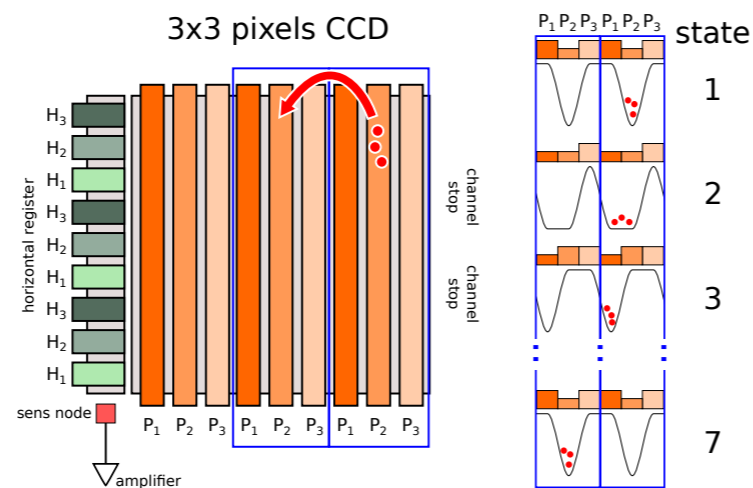

capacitance of the system is set by the SN: $C=0.05\text{pF} \rightarrow 3\mu\text{V}/e$

Lowering the noise: Skipper CCD

- **Main difference:** the Skipper CCD allows multiple sampling of the same pixel without corrupting the charge packet.
- The final pixel value is the average of the samples

$$\text{Pixel value} = \frac{1}{N} \sum_i^N (\text{pixel sample})_i$$

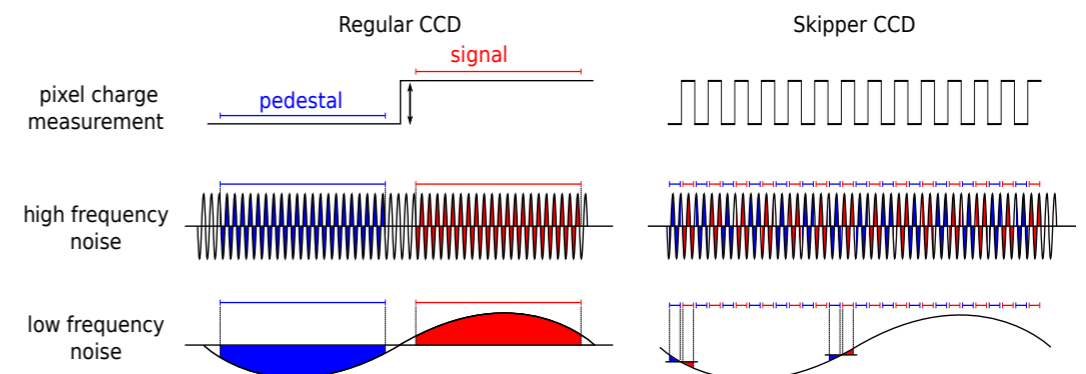

Skipper CCD

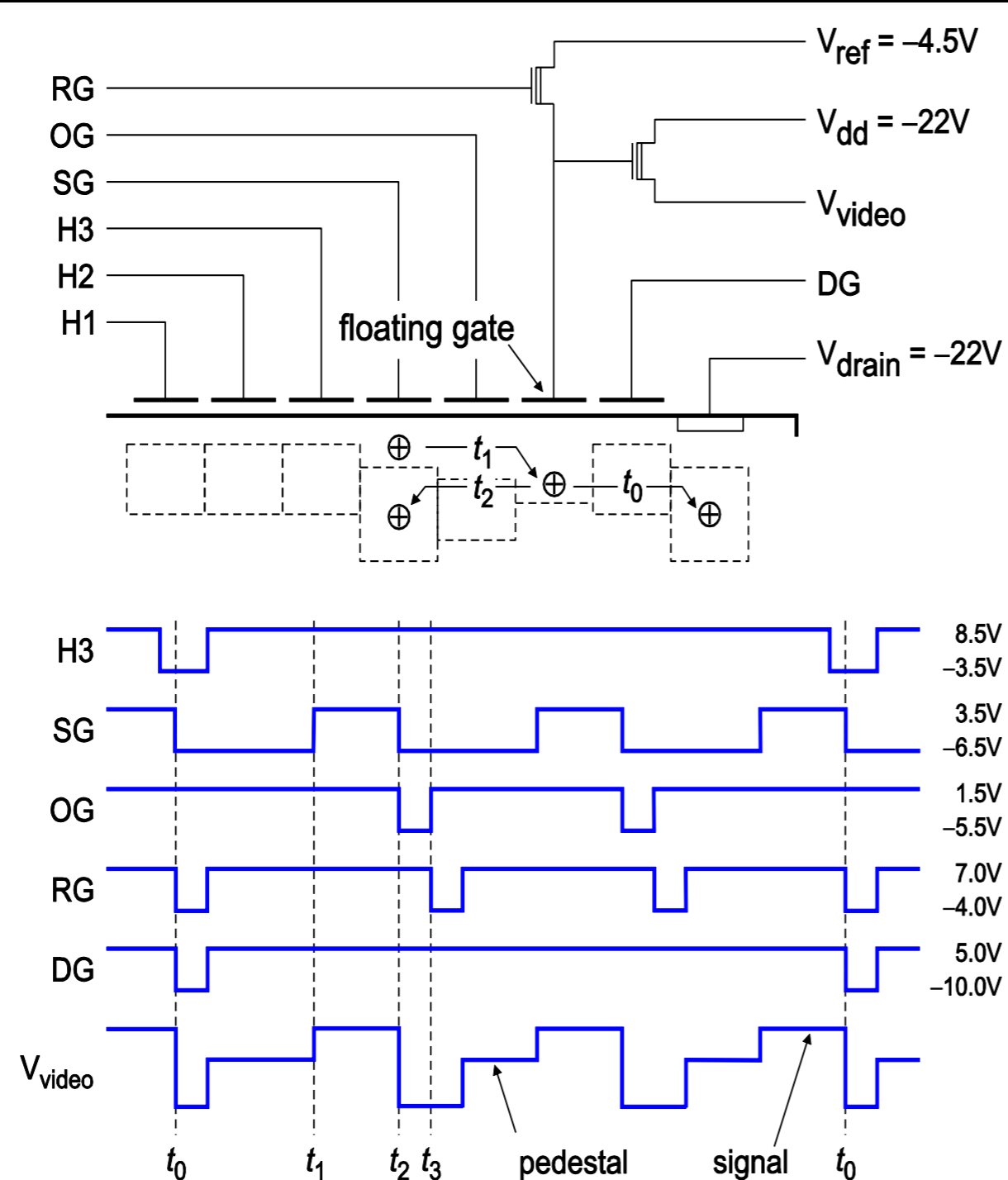

The “skipper” allow multiple readouts of the charge in each pixel.

- Floating gate output instead of floating diffusion output used in regular CCDs.
- The charge can be moved back and forth between

Each readout integration time is kept short to make $1/f$ noise negligible.

A noise reduction of $1/\sqrt{N}$ is achieved for N reads.

The total readout time per pixel increases linearly with N .