



Theory of rare kaon decays

Giancarlo D'Ambrosio
INFN Sezione di Napoli

Collaboration with Crivellin, A., Kitahara, T and Nierste, U.
e-Print: [arXiv:1703.05786](https://arxiv.org/abs/1703.05786) PRD

Closing in on the radiative weak chiral couplings
Luigi Cappiello, Oscar Cata, Giancarlo D'Ambrosio.
[arXiv:1712.10270](https://arxiv.org/abs/1712.10270), EPJC

Flavour issues in warped custodial models: B
anomalies and rare K decays
GD, Abhishek M. Iyer. Dec 21, 2017. 22 pp.
[arXiv:1712.08122](https://arxiv.org/abs/1712.08122)

Rare n Strange 2017: strange physics at LHCb

GD, Lewis Tunstall, Diego Martinez Santos, Veronika Chobanova,
Xabier Cid Vidal, Francesco Dettori, Marc-Olivier Bettler

Collaboration with Teppei Kitahara, Isabel Fernández Suárez, Miriam Lucio Martínez,
Diego Martínez Santos, Veronika Georgieva Chobanova [arXiv:1711.11030](https://arxiv.org/abs/1711.11030)

Collaboration with Teppei Kitahara [arXiv:1707.06999](https://arxiv.org/abs/1707.06999) PRL

Collaboration with M. Knecht, L. E. Greynat, D.

Outline

- $K \rightarrow \pi \nu \nu$
- K -anomalies: ϵ'
- $K_{S,L} \rightarrow \mu \mu$
- weak counterterms

$K \rightarrow \pi \nu \bar{\nu}$

Why we need KOTO and NA62

$$A(s \rightarrow d \nu \bar{\nu})_{\text{SM}} \sim \bar{s}_L \gamma_\mu d_L \quad \bar{\nu}_L \gamma^\mu \nu_L \times \left[\sum_{q=c,t} V_{qs}^* V_{qd} m_q^2 \right]$$

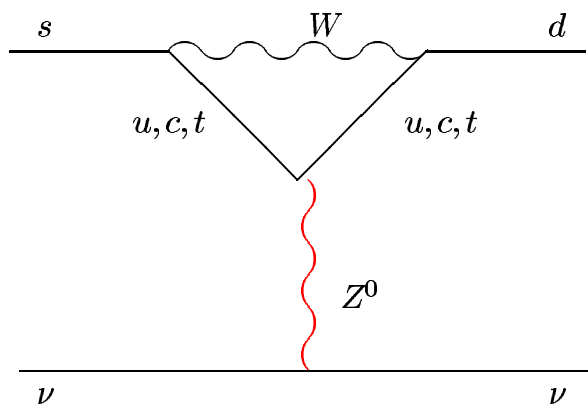

$$\sim [A^2 \lambda^5 (1 - \rho - i\eta) m_t^2 + \lambda m_c^2]$$

SM

$$\underbrace{V - A \otimes V - A}_{\Downarrow}$$

Littenberg

$$\Gamma(K_L \rightarrow \pi^0 \nu \bar{\nu})$$

$$\left\{ \begin{array}{l} \text{CP violating} \\ \Rightarrow J = A^2 \lambda^6 \eta \\ \text{Only } \underline{top} \end{array} \right.$$

SM

$K^+ \rightarrow \pi^+ \nu \bar{\nu}$

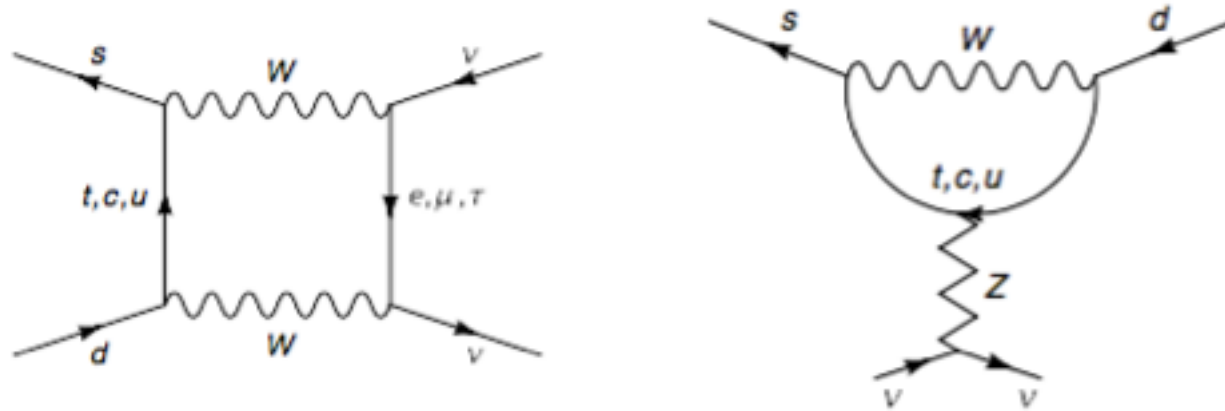

Misiak, Urban; Buras,
Buchalla; Brod, Gorbhan,
Stamou'11, Straub

$$\mathcal{B}(K^+) \sim \kappa_+ \left[\left(\frac{\text{Im}\lambda_t}{\lambda^5} X_t \right)^2 + \left(\frac{\text{Re}\lambda_c}{\lambda} (P_c + \delta P_{c,u}) + \frac{\text{Re}\lambda_t}{\lambda^5} X_t \right)^2 \right]$$

$\lambda_q = V_{qd}^* V_{qs}$

$30\% \pm 2.5\%$

LD

K_{l3}

$$\mathcal{B}(K^\pm) = (8.82 \pm 0.8 \pm 0.3) \times 10^{-11} \quad \text{TH}$$

V_{cb} nonpert QCD

$$(1.73^{+1.15}_{-1.05}) \times 10^{-10}$$

E949

$$< 11 \cdot 10^{-10} \quad 90\% \text{ CL}$$

NA62

$$K_L \rightarrow \pi^0 \nu \bar{\nu}$$

$$B(K_L) = (3.14 \pm 0.17 \pm 0.06) \times 10^{-11} \quad \text{TH}$$

$$B(K_L) < 2.6 \times 10^{-8} \text{ at } 90\% \text{ C.L.} \quad \text{E391a}$$

Model-independent bound, based on SU(2) properties
dim-6 operators for $\bar{s}d\bar{\nu}\nu$

Grossman Nir

$$B(K_L) \leq \frac{\tau_L}{\tau_+} \times B(K^\pm)_{\text{E949}} \leq 1.4 \times 10^{-9} \text{ at } 90\% \text{ C.L.}$$

UV sensitivity

$$\mathcal{L} \sim \frac{1 - 0.3 i}{(180 \text{ TeV})^2} (\bar{s}_L \gamma_\mu d_L \bar{\nu}_L \gamma^\mu \nu_L)$$

News: anomalies in Kaons?

$$\frac{\epsilon'_K}{\epsilon_K} = \frac{1}{\sqrt{2}|\epsilon_K|_{\text{exp}}} \frac{\omega_{\text{exp}}}{(\text{Re}A_0)_{\text{exp}}} \left(-\text{Im}A_0 + \frac{1}{\omega_{\text{exp}}} \text{Im}A_2 \right) \quad \text{where} \quad \frac{1}{\omega} \equiv \frac{\text{Re}A_0}{\text{Re}A_2} = 22.46 \text{ (exp.)}$$

gluon
penguin
 Q_6

EW
penguin
 Q_8

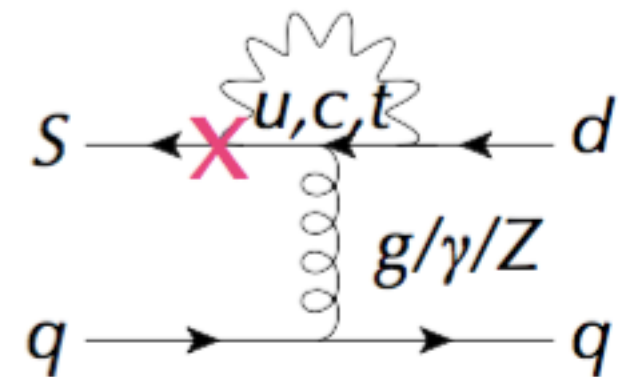

$\langle O_6 \rangle$ and $\langle O_8 \rangle$ have chiral enhancement factor

$$\langle Q_6(\mu) \rangle_0 = -4 \left[\frac{m_K^2}{m_s(\mu) + m_d(\mu)} \right]^2 (F_K - F_\pi) \underline{B_6^{(1/2)}}$$

$$\langle Q_8(\mu) \rangle_2 = \sqrt{2} \left[\frac{m_K^2}{m_s(\mu) + m_d(\mu)} \right]^2 F_\pi \underline{B_8^{(3/2)}}$$

**New lattice
result 2015**

Current situation of $\epsilon'_K / \epsilon_K \propto \text{Im}A_0 - \left(\frac{\text{Re}A_0}{\text{Re}A_2}\right) \text{Im}A_2$

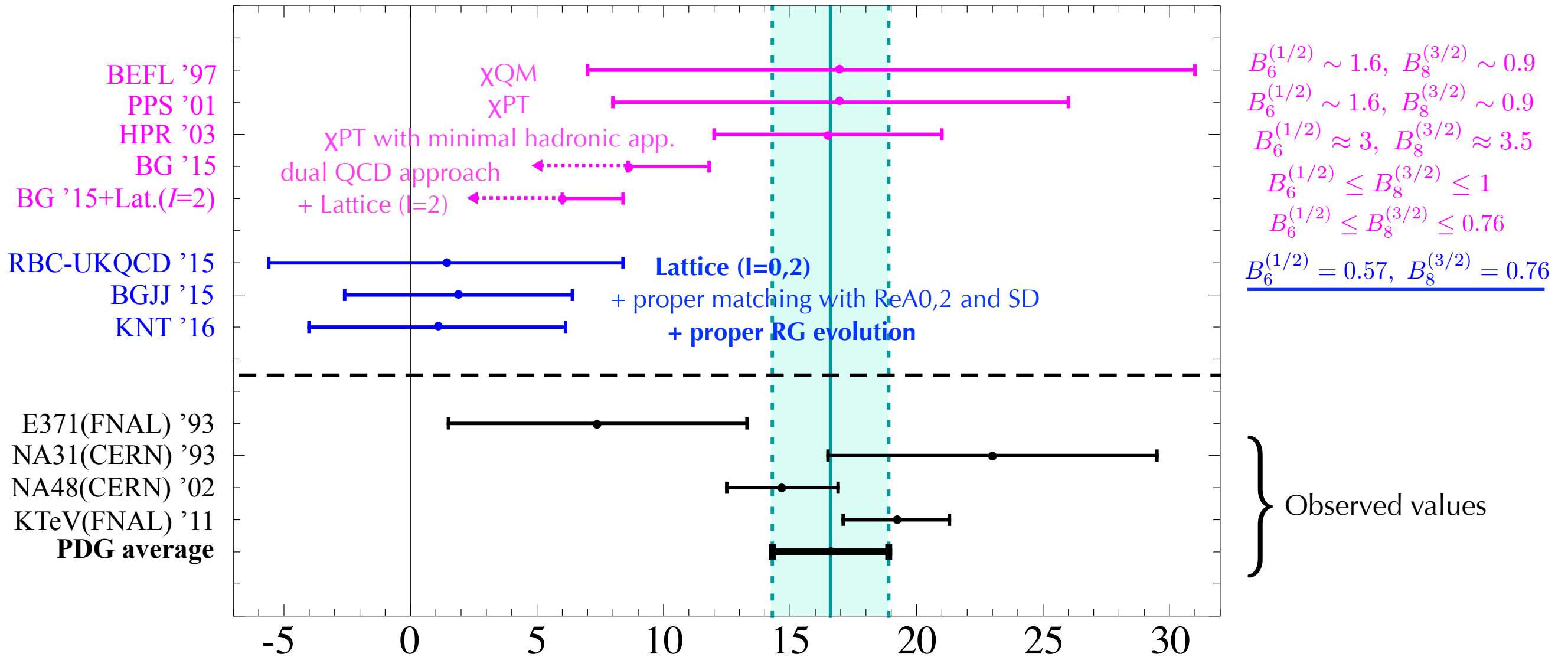

$B_6^{(1/2)} \sim 1.6, B_8^{(3/2)} \sim 0.9$
 $B_6^{(1/2)} \sim 1.6, B_8^{(3/2)} \sim 0.9$
 $B_6^{(1/2)} \approx 3, B_8^{(3/2)} \approx 3.5$
 $B_6^{(1/2)} \leq B_8^{(3/2)} \leq 1$
 $B_6^{(1/2)} \leq B_8^{(3/2)} \leq 0.76$
 $B_6^{(1/2)} = 0.57, B_8^{(3/2)} = 0.76$

large N limit (convention)

$$B_6^{(1/2)} = B_8^{(3/2)} = 1$$

dual QCD prediction

$$B_6^{(1/2)} \leq B_8^{(3/2)} < 1, B_8^{(3/2)} = 0.8$$

$$\text{Re } \epsilon'_K / \epsilon_K \times 10^4$$

	Exp.	χ PT	dual QCD	Lattice (l=0,2)
$\left(\frac{\text{Re}A_0}{\text{Re}A_2}\right)$	22.45 ± 0.05	~ 14	16.0 ± 1.5	31.0 ± 11.1

Models solving ϵ'/ϵ anomaly

- Several new physics models have been studied to explain ϵ'/ϵ anomaly

MSSM -- chargino Z penguin	<i>[M. Endo, S. Mishima, D. Ueda and KY, PLB762(2016)493]</i>
-- gluino Z penguin	<i>[M. Tanimoto and KY, PTEP(2016)no.12,123B02]</i>
-- gluino box	<i>[T.Kitahara, U.Nierste and P.Trempfer, PRL117(2016)no.9, 091802 A.Crivellin, G.D'Ambrosio, T.Kitahara and U.Nierste, 1703.05786]</i>
Vector-like quarks	<i>[C.Bobeth, A.J.Buras, A.Celis and M.Jung, JHEP1704(2017)079]</i>
Little Higgs Model with T-parity	<i>[M.Blanke, A.J.Buras and S.Recksiegel, EPJ.C76 (2016)no.4,182]</i>
331 model	<i>[A.J.Buras and F.De Fazio, JHEP1603(2016)010 & JHEP1608 (2016) 115]</i>
Right handed current	<i>[V.Cirigliano, W.Dekens, J.de Vries and E.Mereghetti, PLB 767 (2017) 1 S.Alioli, V.Cirigliano, W.Dekens, J.de Vries and E.Mereghetti, JHEP1705 (2017)086]</i>

- Different implications (correlations & predictions) for other observables appear depending on models \Rightarrow Possibility of model discriminations

ϵ'_K from isospin breaking

Kagan Neubert,99, Grossman, Kagan Neubert,99

$$\frac{\epsilon'_K}{\epsilon_K} = \frac{1}{\sqrt{2}|\epsilon_K|_{\text{exp}}} \frac{\omega_{\text{exp}}}{(\text{Re}A_0)_{\text{exp}}} \left(-\text{Im}A_0 + \frac{1}{\omega_{\text{exp}}} \text{Im}A_2 \right) \quad \text{where} \quad \frac{1}{\omega} \equiv \frac{\text{Re}A_0}{\text{Re}A_2} = 22.46 \text{ (exp.)}$$

Assuming a discrepancy 2.9 sigmas from SM

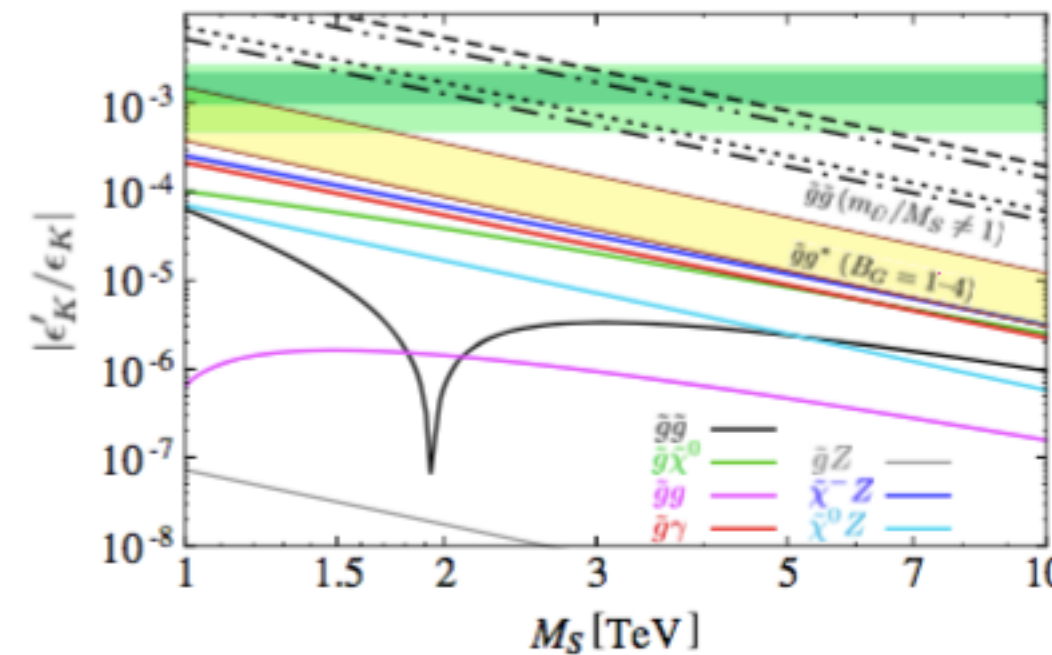
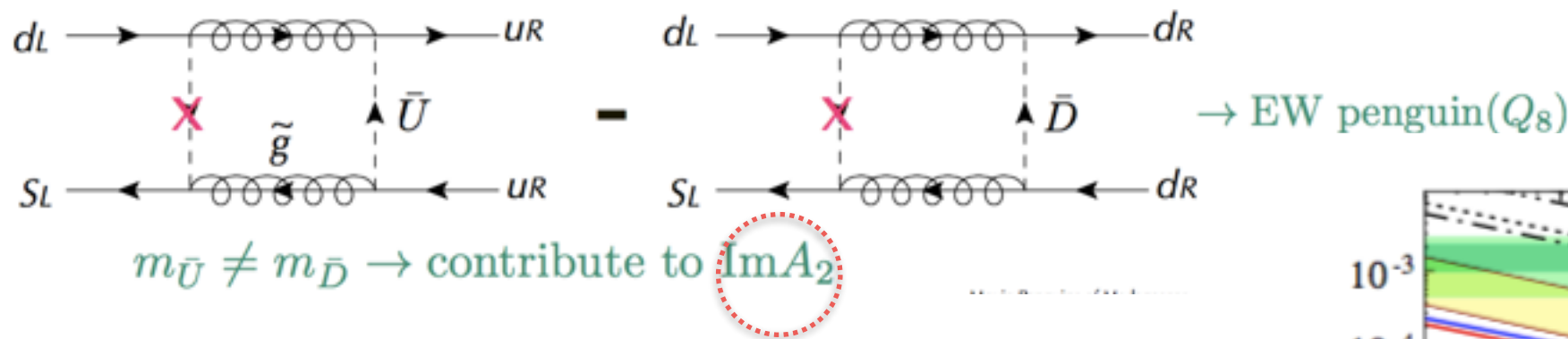
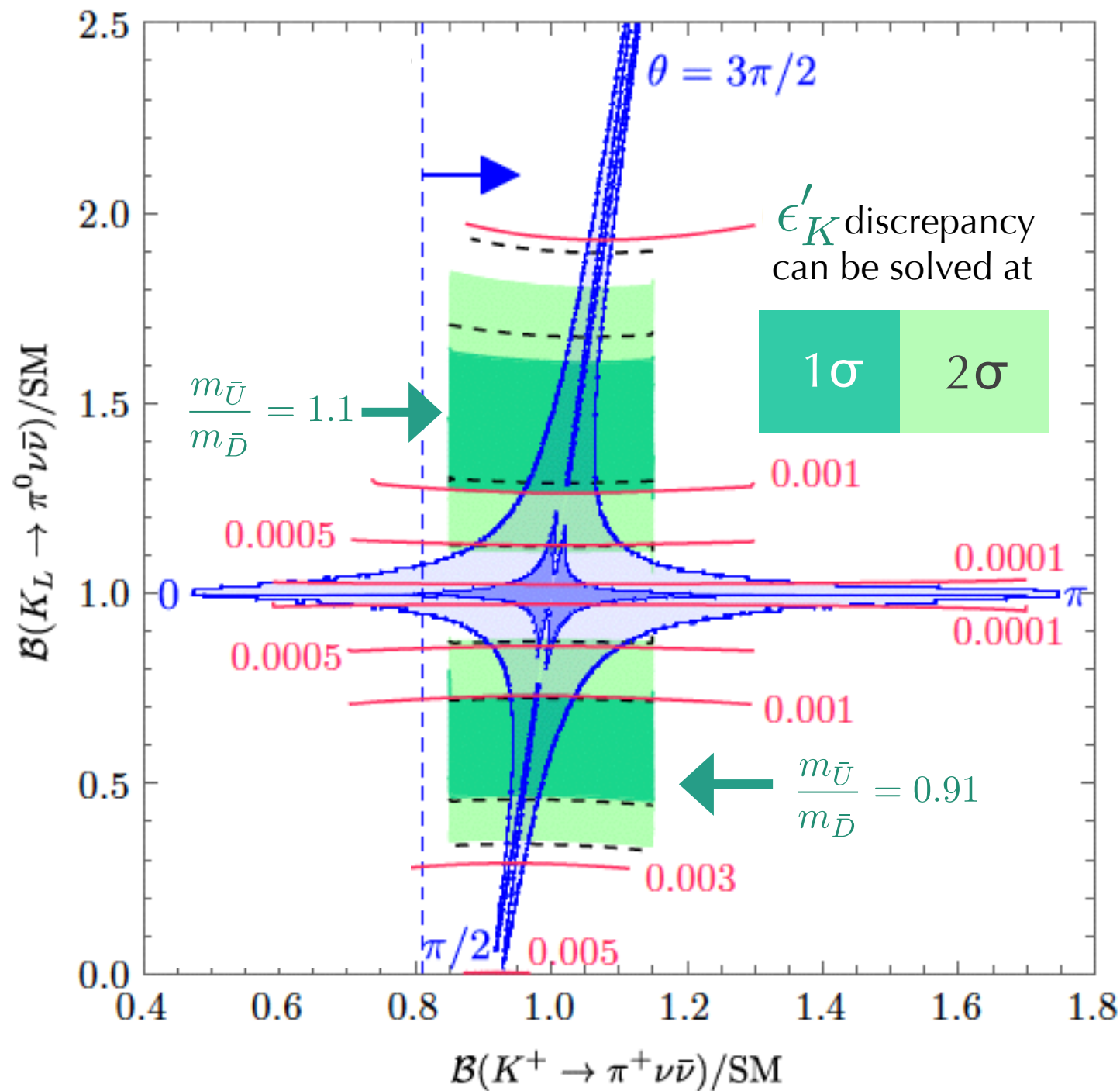

FIG. 3. Individual supersymmetric contributions to $|\epsilon'_K/\epsilon_K|$

$\mathcal{B}(K \rightarrow \pi \nu \nu)$

[Crivellin, D'Ambrosio, TK, Nierste, '17]

$$m_{\tilde{q}_1} = 1.5 \text{ TeV}, m_L = 300 \text{ GeV}$$



more than 10% mass shift of the gluino mass from $M_3 \simeq 1.45 M_S$ is possible in light of the constraint from ϵ'_K

1-10 % mass shift of the gluino mass is possible

$$\mathcal{B}(K_L \rightarrow \pi^0 \nu \bar{\nu}) / \text{SM} \lesssim 2 \quad (1.2)$$

$$\mathcal{B}(K^+ \rightarrow \pi^+ \nu \bar{\nu}) / \text{SM} \lesssim 1.4 \quad (1.1)$$

for a fine-tuning at the 1(10)% level

$m_{\bar{U}} / m_{\bar{D}}$ determines a position of the green band

Positive ϵ'_K predicts a strict correlation

$$\text{sgn} [\mathcal{B}(K_L \rightarrow \pi^0 \nu \bar{\nu}) - \mathcal{B}^{\text{SM}}(K_L \rightarrow \pi^0 \nu \bar{\nu})] = \text{sgn} [m_{\bar{U}} - m_{\bar{D}}]$$

$$\text{sgn} [m_{\bar{U}} - m_{\bar{D}}] \xrightarrow{\epsilon'_K} \arg [m_{Q12}^2]$$

$$\text{sgn} [\mathcal{B}(K_L \rightarrow \pi^0 \nu \bar{\nu}) - \mathcal{B}^{\text{SM}}(K_L \rightarrow \pi^0 \nu \bar{\nu})]$$

Interplay with B-anomalies

Bordone, Buttazzo, Isidori, Monnard

NP is coupled only to the left-handed third generation flavour-singlets (q_{3L} and l_{3L})

$$\mathcal{L}_{\text{eff}} = -\frac{1}{\Lambda^2}(\bar{q}_{3L}\gamma_\mu\sigma^a q_{3L})(\bar{l}_{3L}\gamma^\mu\sigma^a l_{3L}) - \frac{c_{13}}{\Lambda^2}(\bar{q}_{3L}\gamma_\mu q_{3L})(\bar{l}_{3L}\gamma^\mu l_{3L})$$

The interference of NP (weak interaction triplets) with the SM amplitude is always destructive.

The suppression could be as large as 30% relative the SM value.

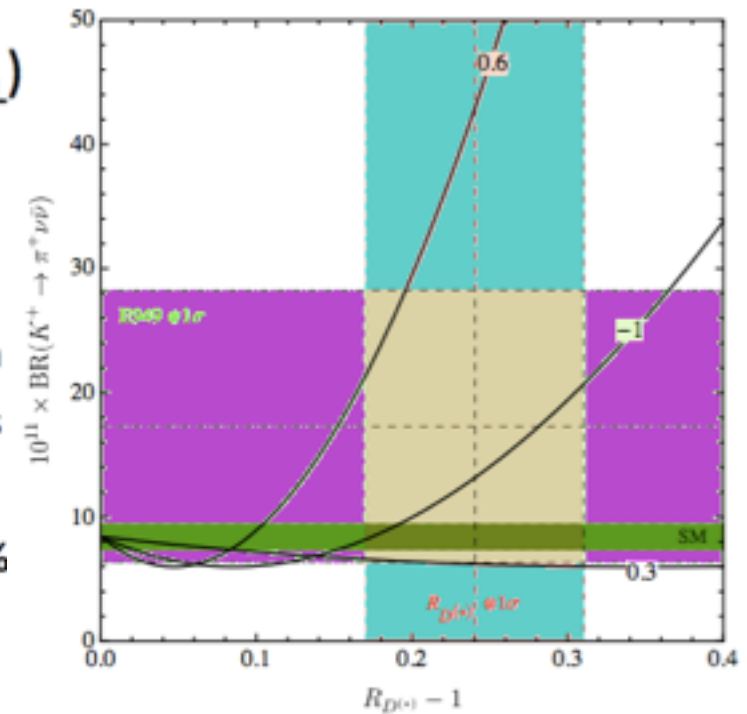

S. Fajfer N. Kořnik, L. Vale Silva

Scalar/triplet leptoquark

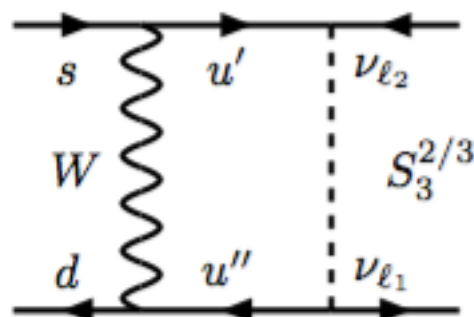

(a) Box diagram (Box).

R_2 and S_3 models @ 1 TeV

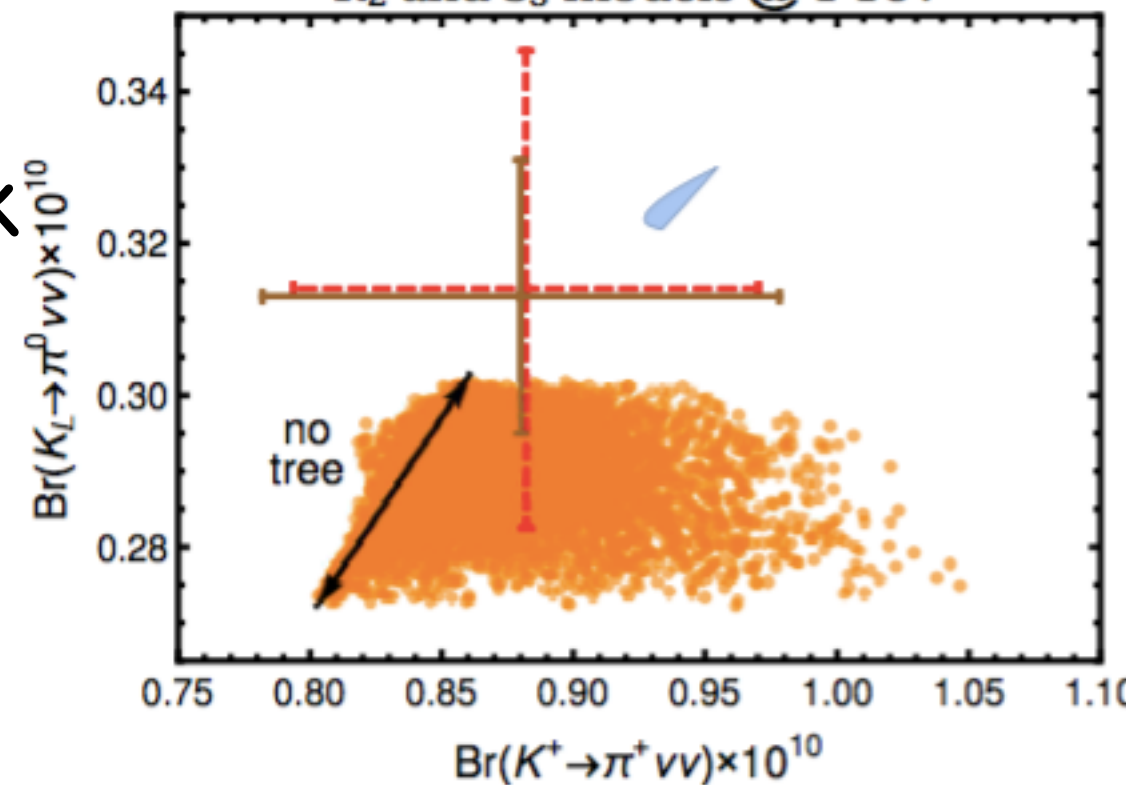

EW vs flavor scale

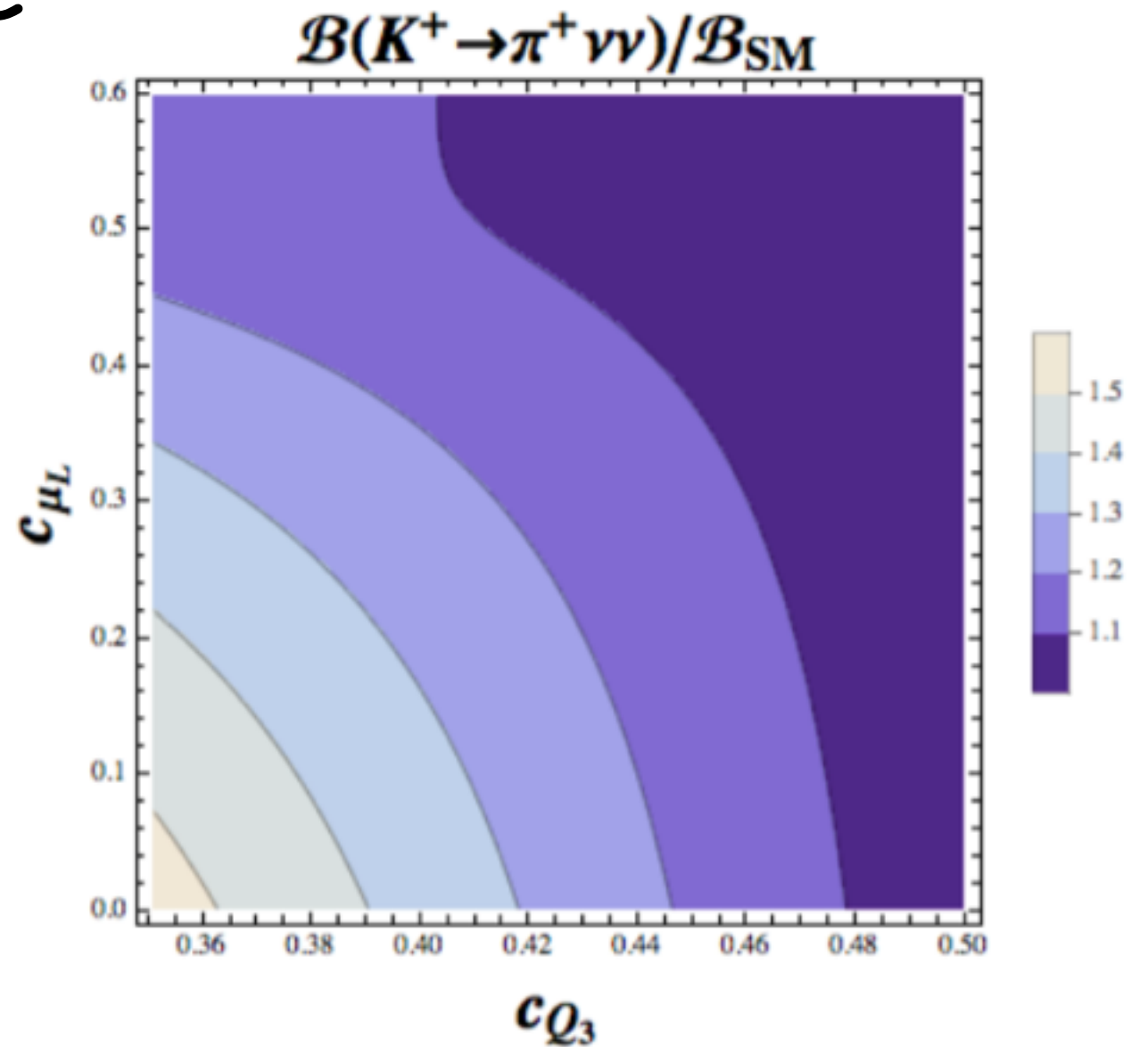
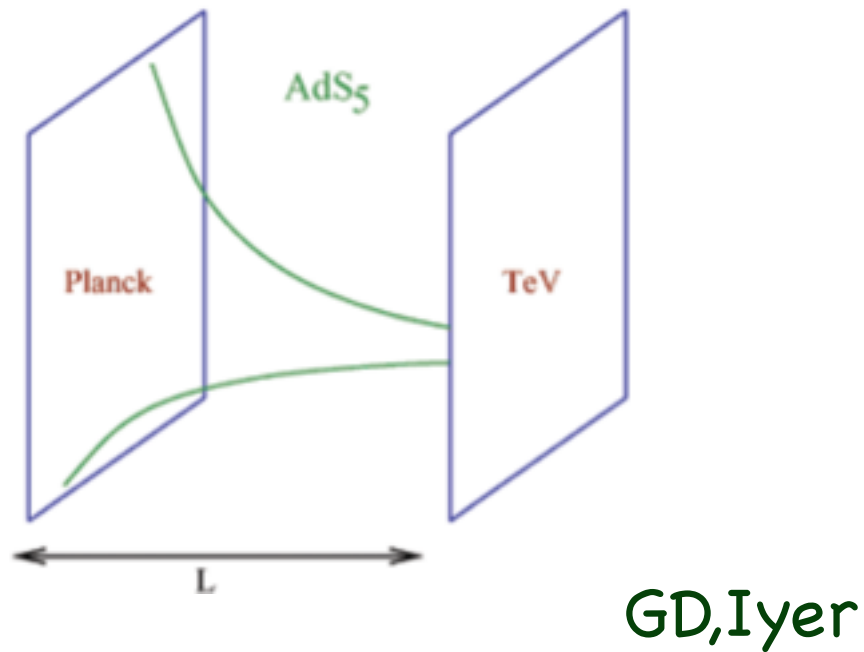

[*a possible shift of paradigm in model-building*] G. Isidori

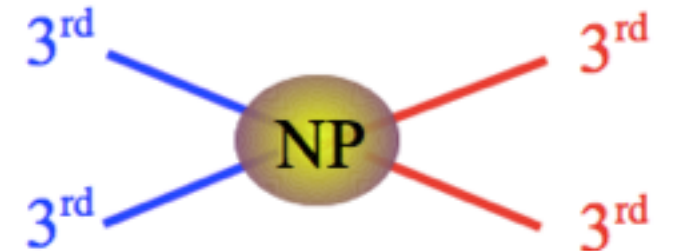
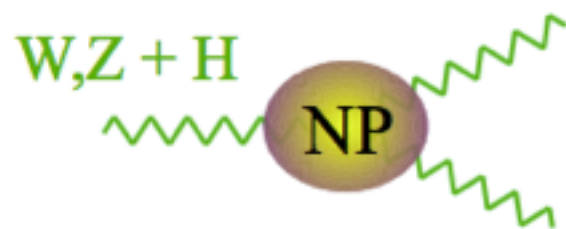

~~large (more interesting...)~~
small (less interesting...)

~~small (less interesting...)~~
large (more interesting...)

Further NA62 K Physics Program

Decay	Physics	Present limit (90% C.L.) / Result	NA62
$\pi^+ \mu^+ e^-$	LFV	1.3×10^{-11}	0.7×10^{-12}
$\pi^+ \mu^- e^+$	LFV	5.2×10^{-10}	0.7×10^{-12}
$\pi^- \mu^+ e^+$	LNV	5.0×10^{-10}	0.7×10^{-12}
$\pi^- e^+ e^+$	LNV	6.4×10^{-10}	2×10^{-12}
$\pi^- \mu^+ \mu^+$	LNV	1.1×10^{-9}	0.4×10^{-12}
$\mu^- \nu e^+ e^+$	LNV/LFV	2.0×10^{-8}	4×10^{-12}
$e^- \nu \mu^+ \mu^+$	LNV	No data	10^{-12}
$\pi^+ \chi^0$	New Particle	$5.9 \times 10^{-11} m_{\chi^0} = 0$	10^{-12}
$\pi^+ \chi \chi$	New Particle	—	10^{-12}
$\pi^+ \pi^+ e^- \nu$	$\Delta S \neq \Delta Q$	1.2×10^{-8}	10^{-11}
$\pi^+ \pi^+ \mu^- \nu$	$\Delta S \neq \Delta Q$	3.0×10^{-6}	10^{-11}
$\pi^+ \gamma$	Angular Mom.	2.3×10^{-9}	10^{-12}
$\mu^+ \nu_h, \nu_h \rightarrow \nu \gamma$	Heavy neutrino	Limits up to $m_{\nu_h} = 350 \text{ MeV}$	
R_K	LU	$(2.488 \pm 0.010) \times 10^{-5}$	> $\times 2$ better
$\pi^+ \gamma \gamma$	χ PT	< 500 events	10^5 events
$\pi^0 \pi^0 e^+ \nu$	χ PT	66000 events	$O(10^6)$
$\pi^0 \pi^0 \mu^+ \nu$	χ PT	-	$O(10^5)$

Rare Kaon decay program at LHCb

	PDG	Prospects
$K_S \rightarrow \mu\mu$	$< 9 \times 10^{-9}$ at 90% CL	(LD) $(5.0 \pm 1.5) \cdot 10^{-12}$ NP $< 10^{-11}$
$K_S \rightarrow \mu\mu\mu\mu$	—	SM LD $\sim 2 \times 10^{-14}$
$K_S \rightarrow ee\mu\mu$	—	$\sim 10^{-11}$
$K_S \rightarrow eeee$	—	$\sim 10^{-10}$
$K_S \rightarrow \pi^0\mu\mu$	$(2.9 \pm 1.3) \cdot 10^{-9}$	$\sim 10^{-9}$
$K_S \rightarrow \pi^+\pi^-e^+e^-$	$(4.79 \pm 0.15) \cdot 10^{-5}$	SM LD $\sim 10^{-5}$
$K_S \rightarrow \pi^+\pi^-\mu^+\mu^-$	—	SM LD $\sim 10^{-14}$

Rare n Strange 2017: strange physics at LHCb

GD, Lewis Tunstall, Diego Martinez Santos, Veronika Chobanova,
 Xabier Cid Vidal, Francesco Dettori, Marc-Olivier Bettler,
 Teppei Kitahara, Kei Yamamoto

$$K_{L,S} \rightarrow \mu\mu$$

$K_L \rightarrow \mu\mu$

$$\Gamma(K_L^0 \rightarrow \mu^+\mu^-) / \Gamma(K_L^0 \rightarrow \pi^+\pi^-)$$

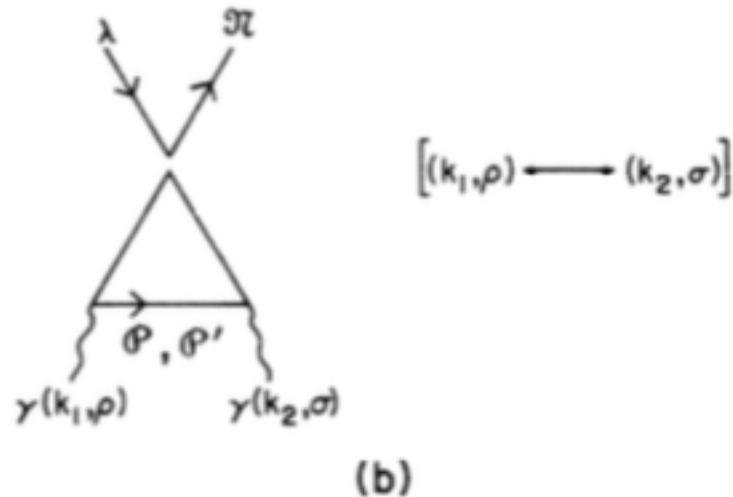
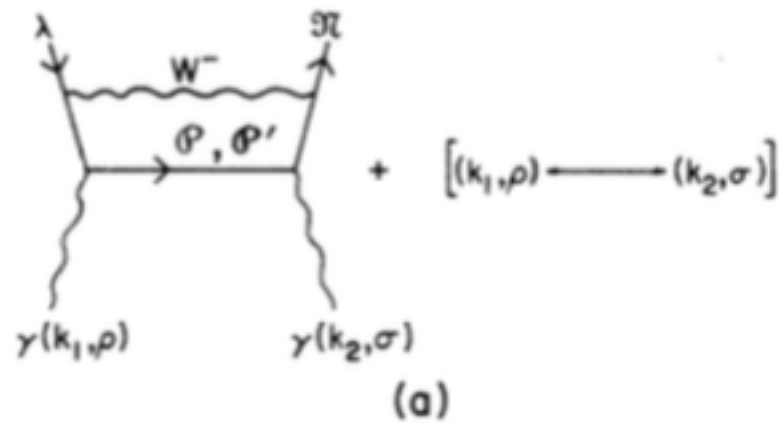

FIG. 7. Leading contributions to $\lambda + \bar{\pi} \rightarrow \gamma + \gamma$. To leading order in M_W^{-2} , the diagrams in (a) reduce to those of (b).

Gaillard Lee

VALUE (10^{-6})	EVTS	DOCUMENT ID	TECN	CO
3.48 ± 0.05	OUR AVERAGE			
3.474 ± 0.057	6210	AMBROSE	2000	B871
3.87 ± 0.30	179	¹ AKAGI	1995	SPEC
3.38 ± 0.17	707	HEINSON	1995	B791
... We do not use the following data for averages, fits, limits, etc. ...				
$3.9 \pm 0.3 \pm 0.1$	178	² AKAGI	1991B	SPEC

$$\mathcal{B}(K_L \rightarrow \mu^+\mu^-)_{\text{exp}} = (6.84 \pm 0.11) \times 10^{-9}$$

$K_L \rightarrow \gamma\gamma$ |_{exp} **known**

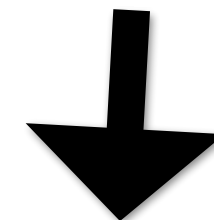

Dispersive calculation: **Re A**, **Im A**

We do not know the sign of $A(K_L \rightarrow \gamma\gamma)$

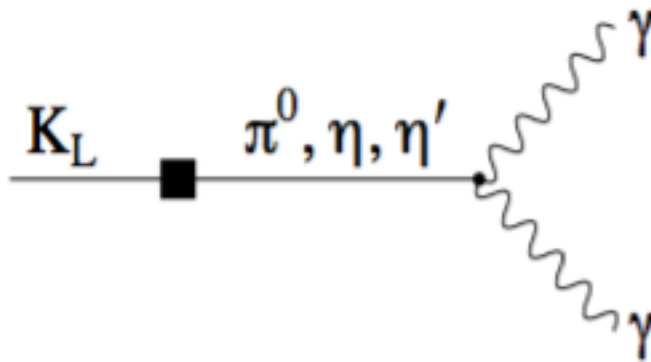

$$\begin{aligned}
 A(K_L \rightarrow 2\gamma_\perp)_{O(p^4)} &= A(K_L \rightarrow \pi^0 \rightarrow 2\gamma_\perp) + A(K_L \rightarrow \eta_8 \rightarrow 2\gamma_\perp) \\
 &= A(K_L \rightarrow \pi^0)A(\pi^0 \rightarrow 2\gamma_\perp) \left[\frac{1}{M_K^2 - M_\pi^2} + \frac{1}{3} \cdot \frac{1}{M_K^2 - M_8^2} \right] \simeq 0
 \end{aligned}$$

$K_L \rightarrow \mu\mu$

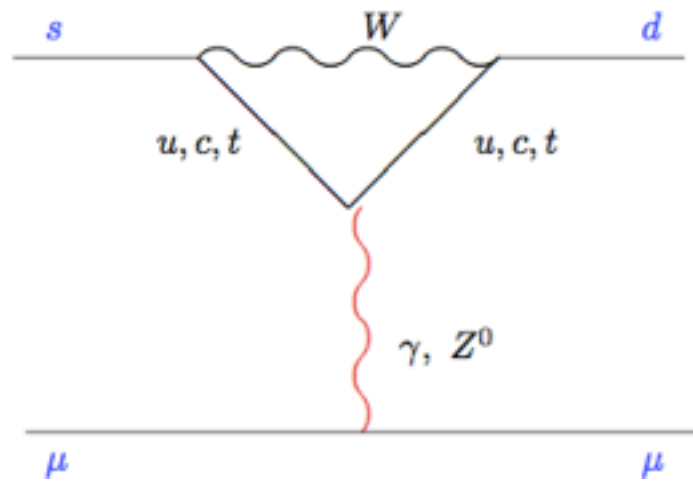

\ll

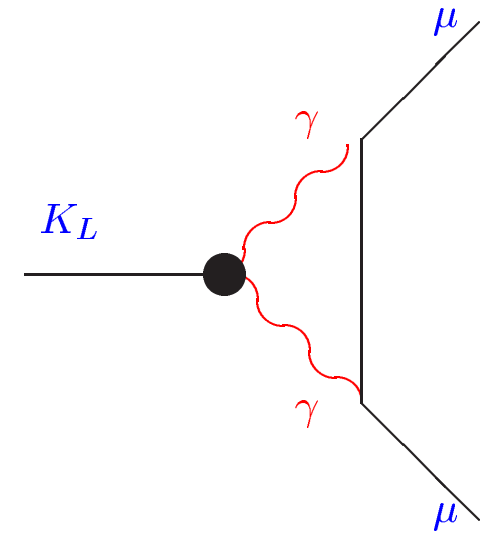

$$\frac{\Gamma(K_L \rightarrow \mu\bar{\mu})}{\Gamma(K_L \rightarrow \gamma\gamma)} \sim |ReA|^2 + |ImA|^2$$

Absorptive calculation
model independent

27.14

Subtracting from expt. the Absorptive contribution

$$0.98 \pm 0.55 = |ReA|^2 = (\chi_{\gamma\gamma}(M_\rho) + \chi_{\text{short}} - 5.12)^2$$

$$|\chi_{\text{short}}^{\text{SM}}| = 1.96(1.11 - 0.92\bar{\rho})$$

$K_L \rightarrow \mu\mu$: our sign ignorance

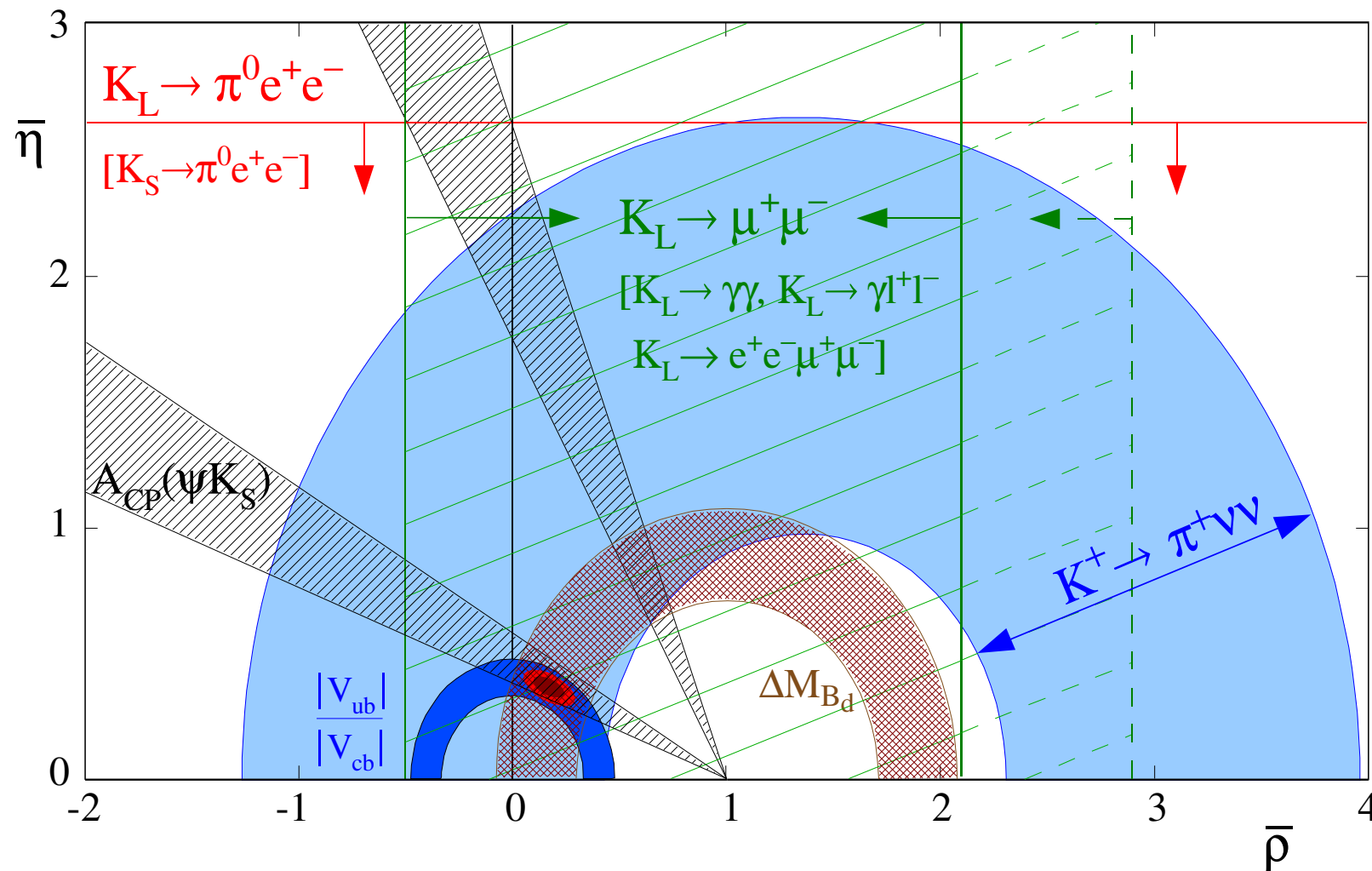

We do not know the sign
We know the sign

$K_S \rightarrow \mu\mu$

PHYSICAL REVIEW D

VOLUME 10, NUMBER 3

1 AUGUST 1974

Rare decay modes of the K mesons in gauge theories

M. K. Gaillard* and Benjamin W. Lee†

National Accelerator Laboratory, Batavia, Illinois 60510‡

(Received 4 March 1974)

Rare decay modes of the kaons such as $K \rightarrow \mu\bar{\mu}$, $K \rightarrow \pi\nu\bar{\nu}$, $K \rightarrow \gamma\gamma$, $K \rightarrow \pi\gamma\gamma$, and $K \rightarrow \pi e\bar{e}$ are of theoretical interest since here we are observing higher-order weak and electromagnetic interactions. Recent advances in unified gauge theories of weak and electromagnetic interactions allow in principle unambiguous and finite predictions for these processes. The above processes, which are "induced" $|\Delta S|=1$ transitions, are a good testing ground for the cancellation mechanism first invented by Glashow, Iliopoulos, and Maiani (GIM) in order to banish $|\Delta S|=1$ neutral currents. The experimental suppression of $K_L \rightarrow \mu\bar{\mu}$ and nonsuppression of $K_L \rightarrow \gamma\gamma$ must find a natural explanation in the GIM mechanism which makes use of extra quark(s). The procedure we follow is the following: We deduce the effective interaction Lagrangian for $\lambda + \bar{\kappa} \rightarrow l + \bar{l}$ and $\lambda + \bar{\kappa} \rightarrow \gamma + \gamma$ in the free-quark model; then the appropriate matrix elements of these operators between hadronic states are evaluated with the aid of the principles of conserved vector current and partially conserved axial-vector current. We focus our attention on the Weinberg-Salam model. In this model, $K \rightarrow \mu\bar{\mu}$ is suppressed due to a fortuitous cancellation. To explain the small $K_L - K_S$ mass difference and nonsuppression of $K_L \rightarrow \gamma\gamma$, it is found necessary to assume $m_{\phi}/m_{\phi'} \ll 1$, where m_{ϕ} is the mass of the proton quark and $m_{\phi'}$ the mass of the charmed quark, and $m_{\phi'} < 5$ GeV. We present a phenomenological argument which indicates that the average mass of charmed pseudoscalar states lies below 10 GeV. The effective interactions so constructed are then used to estimate the rates of other processes. Some of the results are the following: $K_S \rightarrow \gamma\gamma$ is suppressed; $K_S \rightarrow \pi\gamma\gamma$ proceeds at a normal rate, but $K_L \rightarrow \pi\gamma\gamma$ is suppressed; $K_L \rightarrow \pi\nu\bar{\nu}$ is very much forbidden, and $K^+ \rightarrow \pi^+\nu\bar{\nu}$ occurs with the branching ratio of $\sim 10^{-10}$. $K^+ \rightarrow \pi^+e\bar{e}$ has the

Run1 data (3 fb⁻¹)

$$B(K_S^0 \rightarrow \mu^+\mu^-) < 0.8(1.0) \times 10^{-9}$$

90%, 95% CL

factor 11 improvement

VALUE (10 ⁻⁹)	CL%	DOCUMENT ID	TECN
< 9	90	¹ AAIJ	2013G LHCb
••• We do not use the following data for averages, fits, limits, etc. •••			
< 0.032 × 10 ⁴	90	GJESDAL	1973 ASPK
< 0.7 × 10 ⁴	90	HYAMS	1969B OSPK

¹ AAIJ 2013G uses 1.0 fb⁻¹ of pp collisions at $\sqrt{s} = 7$ TeV. They obtained $B(K_S^0 \rightarrow \mu^+\mu^-) < 11 \times 10^{-9}$ at 95% C.L.

$K_S \rightarrow \mu\mu$

Ecker Pich '90

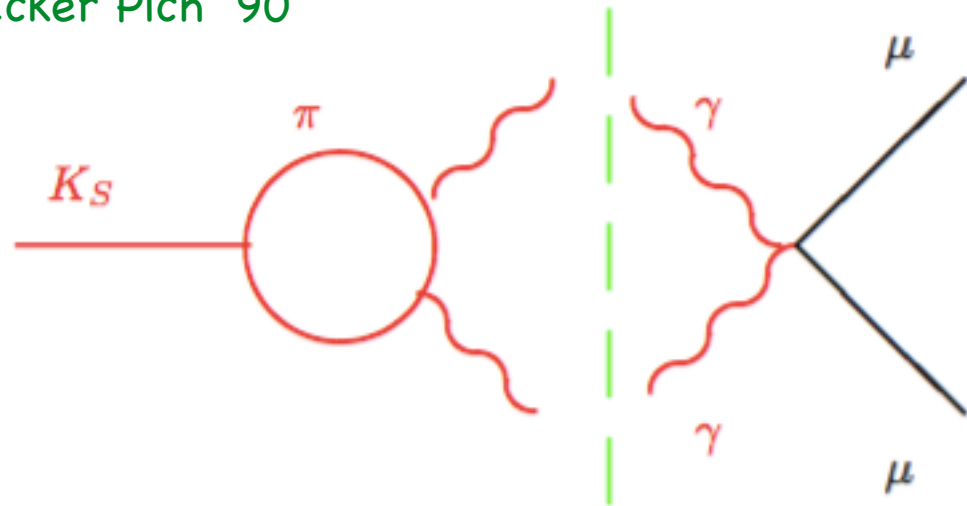

No CP conserving Short Distance due to Furry Theorem

Gaillard Lee

LD 5×10^{-12} 30% TH err

Short Distance

SM	$10^{-5} \Im(V_{ts}^* V_{td}) ^2 \sim 10^{-13}$
NP	few 10^{-11} allowed

LHCb

$< 8 \times 10^{-10}$ 90%CL

$K_S \rightarrow \mu\mu$: how to improve the THEORY error

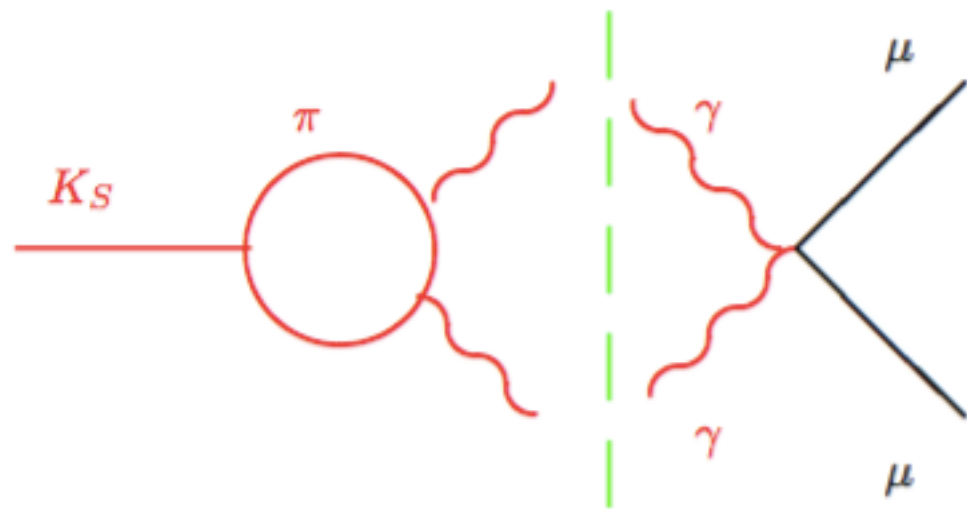

Dispersive treatment of $K_S \rightarrow \gamma\gamma$ and $K_S \rightarrow \gamma l^+ l^-$

Gilberto Colangelo, Ramon Stucki, and Lewis C. Tunstall

LD 5×10^{-12} 20% TH err

$$K_S \rightarrow \gamma\mu\mu$$

$$K_S \rightarrow \mu\mu\mu\mu$$

$$K_S \rightarrow e e \mu \mu$$

$$K_S \rightarrow \gamma\gamma$$

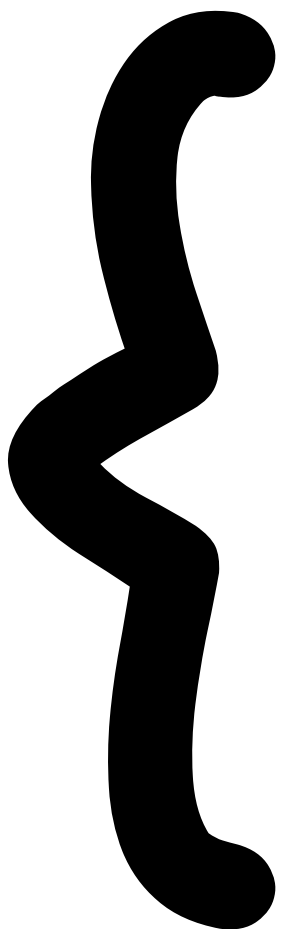

CLEAR Flavor tagging

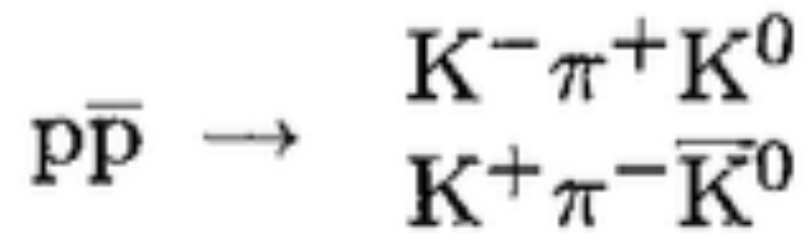

$$\frac{R(\tau)}{\bar{R}(\tau)} \propto (1 \mp 2\text{Re}(\epsilon_L))(e^{-\Gamma_S \tau} + |\eta_{+-}|^2 e^{-\Gamma_L \tau} \pm 2|\eta_{+-}| e^{-\frac{1}{2}(\Gamma_S + \Gamma_L)\tau} \cos(\Delta m \tau - \phi_{+-}))$$

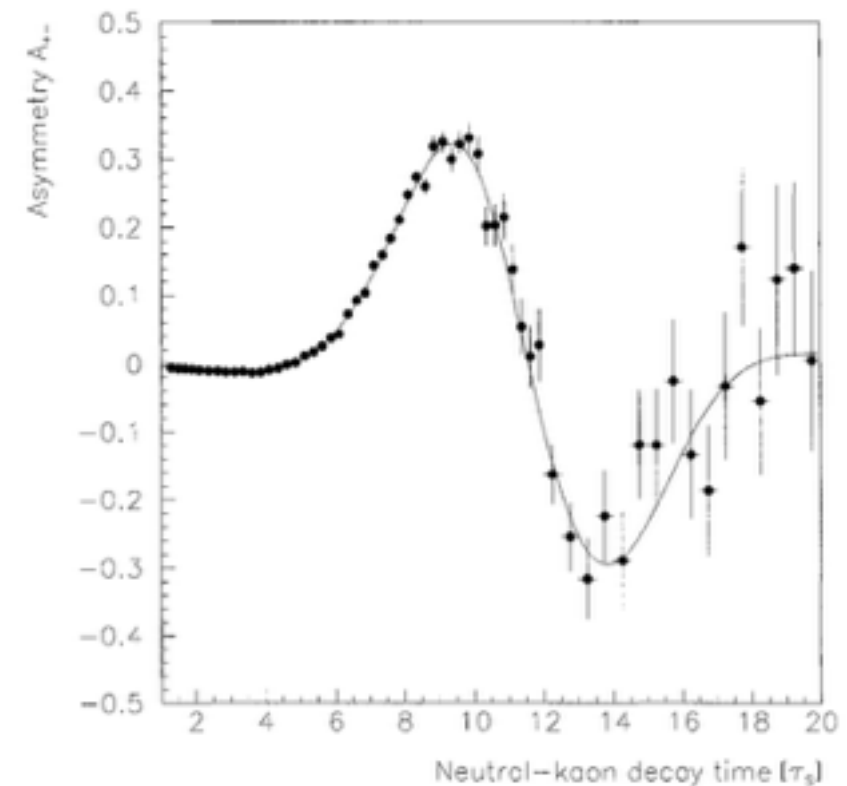
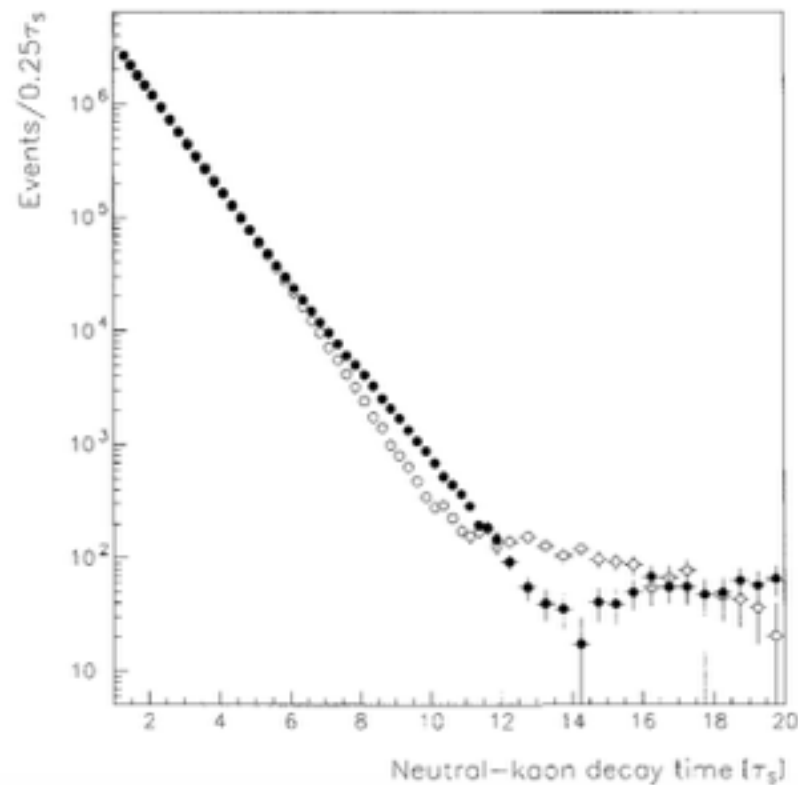

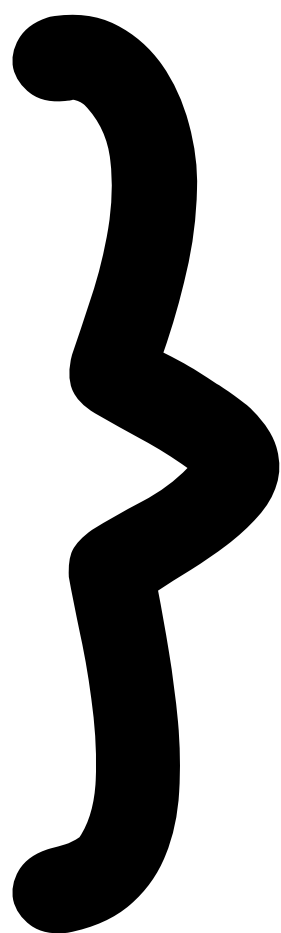

Can we study $K^0(t)$?

GD, Kitahara
1707.06999 PRL

$$pp \rightarrow K^0 K^- X$$

$$pp \rightarrow K^{*+} X \rightarrow K^0 \pi^+ X$$

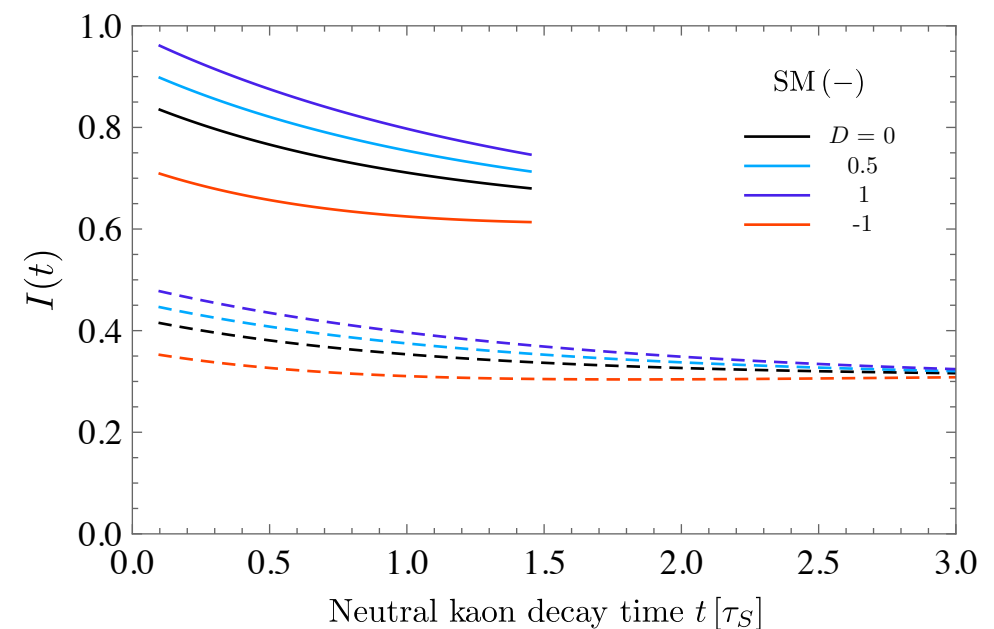
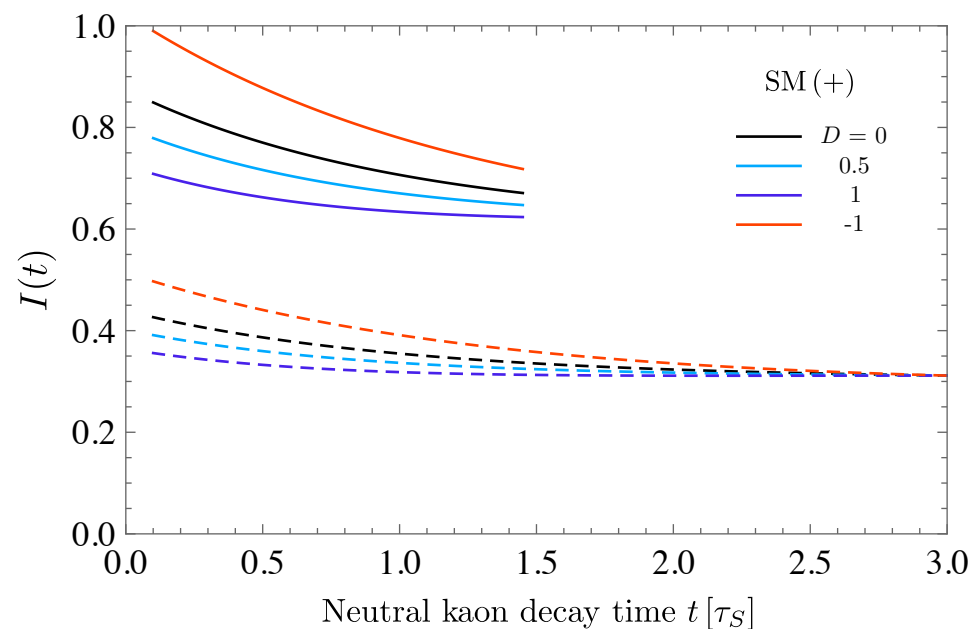

$$|\bar{K}^0(t)\rangle = \frac{1}{\sqrt{2}(1 \pm \bar{\epsilon})} \left[e^{-iH_S t} (|K_1\rangle + \bar{\epsilon}|K_2\rangle) \right. \\ \left. \pm e^{-iH_L t} (|K_2\rangle + \bar{\epsilon}|K_1\rangle) \right]$$

$$D = \frac{K^0 - \bar{K}^0}{K^0 + \bar{K}^0}$$

- **Short distance interfering** with Large CP conserving LD contribution !
- We may be able to study the time evolution of K^0 by tracking the associated particles (K^-)

$$\sum_{\text{spin}} \mathcal{A}(K_1 \rightarrow \mu^+ \mu^-)^* \mathcal{A}(K_2 \rightarrow \mu^+ \mu^-)$$

$$\sim \text{Im}[\lambda_t] y'_{7A} \left\{ A_{L\gamma\gamma}^\mu - 2\pi \sin^2 \theta_W (\text{Re}[\lambda_t] y'_{7A} + \text{Re}[\lambda_c] y_c) \right\}$$

Short distance window

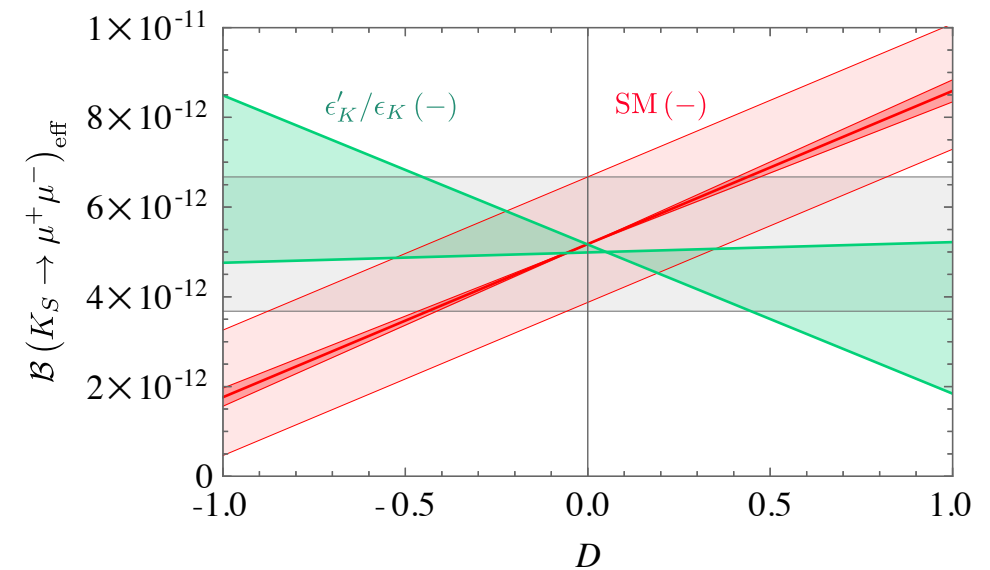
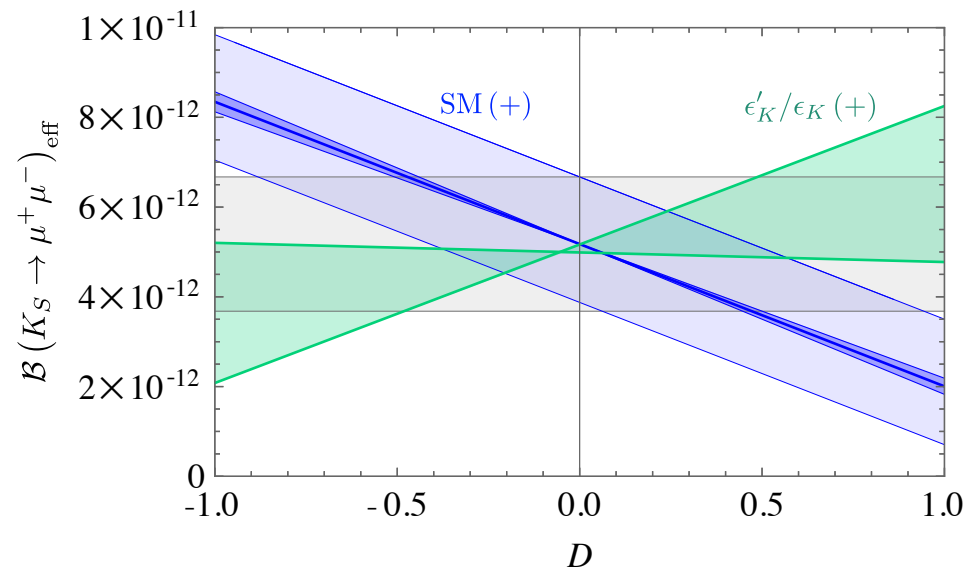

$$\begin{aligned} & \mathcal{B}(K_S \rightarrow \mu^+ \mu^-)_{\text{eff}} \\ &= \tau_S \left[\int_{t_{\min}}^{t_{\max}} dt \left(\Gamma(K_1) e^{-\Gamma_S t} + \frac{D}{8\pi M_K} \sqrt{1 - \frac{4m_\mu^2}{M_K^2}} \sum_{\text{spin}} \text{Re} \left[e^{-i\Delta M_K t} \mathcal{A}(K_1)^* \mathcal{A}(K_2) \right] e^{-\frac{\Gamma_S + \Gamma_L}{2} t} \right) \varepsilon(t) \right] \\ & \times \left(\int_{t_{\min}}^{t_{\max}} dt e^{-\Gamma_S t} \varepsilon(t) \right)^{-1}, \end{aligned}$$

Collaboration with Tepei Kitahara, Isabel Fernández Suárez, Miriam Lucio Martínez, Diego Martínez Santos, Veronika Georgieva Chobanova arXiv:1711.11030, JHEP

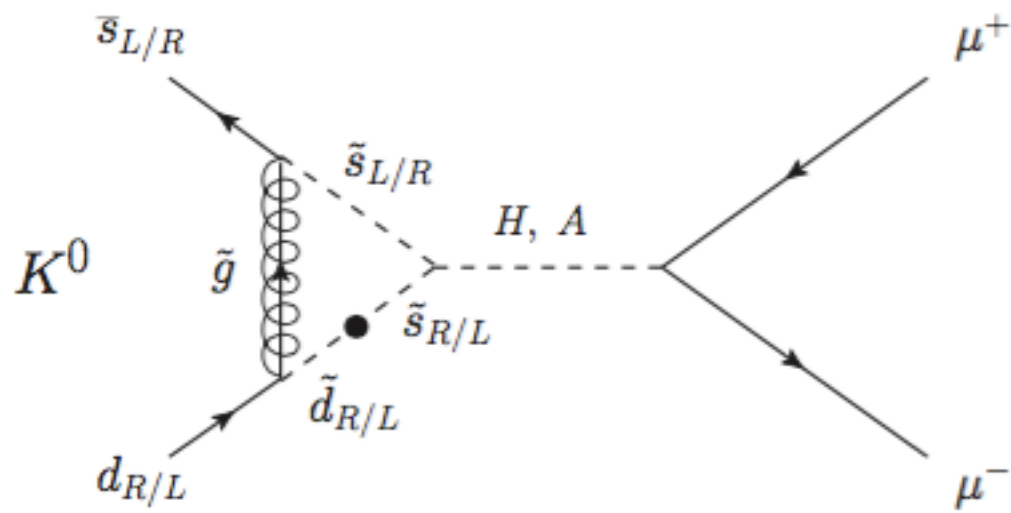

Miriam Lucio

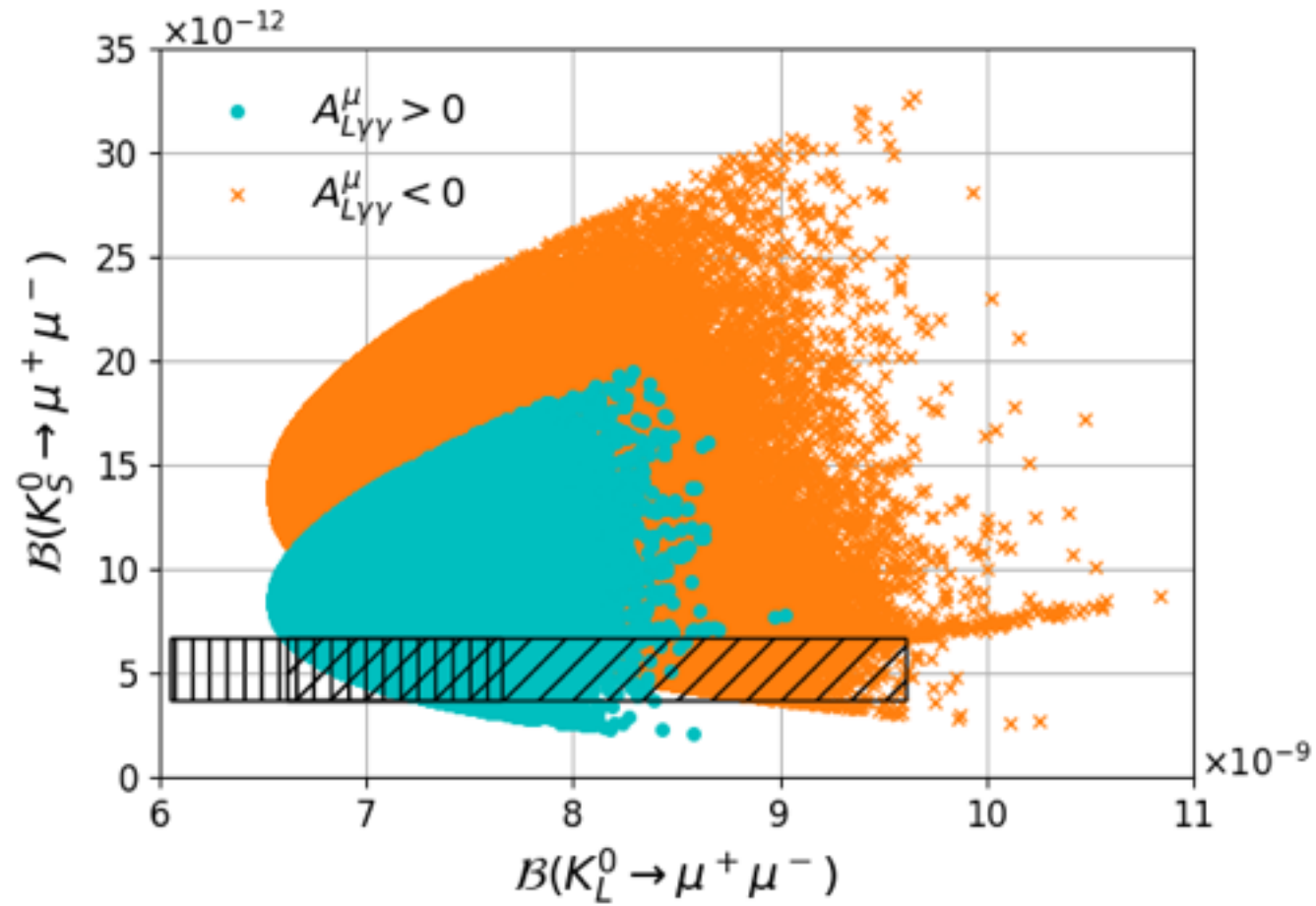

QCD and EFT

Chiral Perturbation theory

χ PT effective field theory approach based on **two** assumptions

- π 's Goldstone bosons of $SU(3)_L \times SU(3)_R \rightarrow SU(3)_V$ $SU(3)_L \times SU(3)_R$ symm. \mathcal{L}_{QCD} $m_q = 0$
- **(chiral) power counting** There is a small expansion parameter $p^2/\Lambda^2_{\chi\text{SB}}$ $\Lambda_{\chi\text{SB}} \approx 4 \pi F_\pi \sim 1.2 \text{ GeV}$

Chiral sym. breaking through dim. parameter F_π, χ related to
 $\langle 0 | J_{5\mu} | \pi \rangle, \langle 0 | q_L q_R | 0 \rangle$

$F_\pi \approx 93 \text{ MeV}$

$$\mathcal{L}_S = \mathcal{L}_S^2 + \mathcal{L}_S^4 + \dots = \frac{F_\pi^2}{4} \overbrace{\langle D_\mu U D^\mu U^\dagger + \chi U^\dagger + U \chi^\dagger \rangle}^{\pi \rightarrow l\nu, \pi\pi \rightarrow \pi\pi, K \rightarrow \pi\dots} + \sum_i \overbrace{L_i O_i}^{K \rightarrow \pi\dots} + \dots$$

Fantastic chiral prediction

$$A_{\pi\pi} \sim (s - m_\pi^2) / F_\pi^2$$

L_i Gasser Leutwyler coeff determined from expts.
 O_i p^4 operator

$$\mathcal{L}_{\Delta S=1} = \mathcal{L}_{\Delta S=1}^2 + \mathcal{L}_{\Delta S=1}^4 + \dots = G_8 F^4 \underbrace{\langle \lambda_6 D_\mu U^\dagger D^\mu U \rangle}_{K \rightarrow 2\pi/3\pi} + G_8 F^2 \sum_i \underbrace{N_i W_i}_{K^+ \rightarrow \pi^+ \gamma\gamma, K \rightarrow \pi l^+ l^-} + \dots$$

Vector Meson Dominance in the strong sector

Ecker, Gasser, de Rafael, Pich

L_i	L_i expts	V	A	Total (Scalar incl.)	Total QCD rel. incl.
L_1	0.4 ± 0.3	0,6	0	0,6	0,9
L_2	1.4 ± 0.3	1,2	0	1,2	1,8
L_3	-3.5 ± 1.1	-3,6	0	-3,0	-4,9
L_4	-0.3 ± 0.5	0	0	0	0
L_5	1.4 ± 0.5	0	0	1,4	1,4
L_6	-0.2 ± 0.3	0	0	0	0
L_7	-0.4 ± 0.2	0	0	-0,3	-0,3
L_8	0.9 ± 0.3	0	0	0,9	0,9
L_9	6.9 ± 0.7	6,9	0	6,9	7,3
L_{10}	-5.5 ± 0.7	-10	4	-6,0	-5,5

QCD inspired relations relations

$$F_V = 2G_V = \sqrt{2}f_\pi$$

$$F_A = f_\pi$$

$$M_A = \sqrt{2}M_V$$

KSFR: $G_V = \sqrt{2} F_\pi$
determined by dominance
of pion, V,A to recover
QCD short distance
constraints

$$L_1^V = \frac{L_2^V}{2} = -\frac{L_3^V}{6} = \frac{G_V^2}{8M_V^2}, \quad L_9^V = \frac{F_V G_V}{2M_V^2}, \quad L_{10}^{V+A} = -\frac{F_V^2}{4M_V^2} + \frac{F_A^2}{4M_A^2}$$

QCD inspired relations relations

$$L_1^V = L_2^V / 2 = -L_3^V / 6 = L_9^V / 8 = -L_{10}^{V+A} / 6 = f_\pi^2 / (16M_V^2)$$

Minimal Hadronic Ansatz

(MHA)

- Traditional wisdom: low energy VERY WELL approximated by π 's ,V,A
- Short distance: QCD
- A good interpolation among the two regimes is sufficient for a good description of the correlators

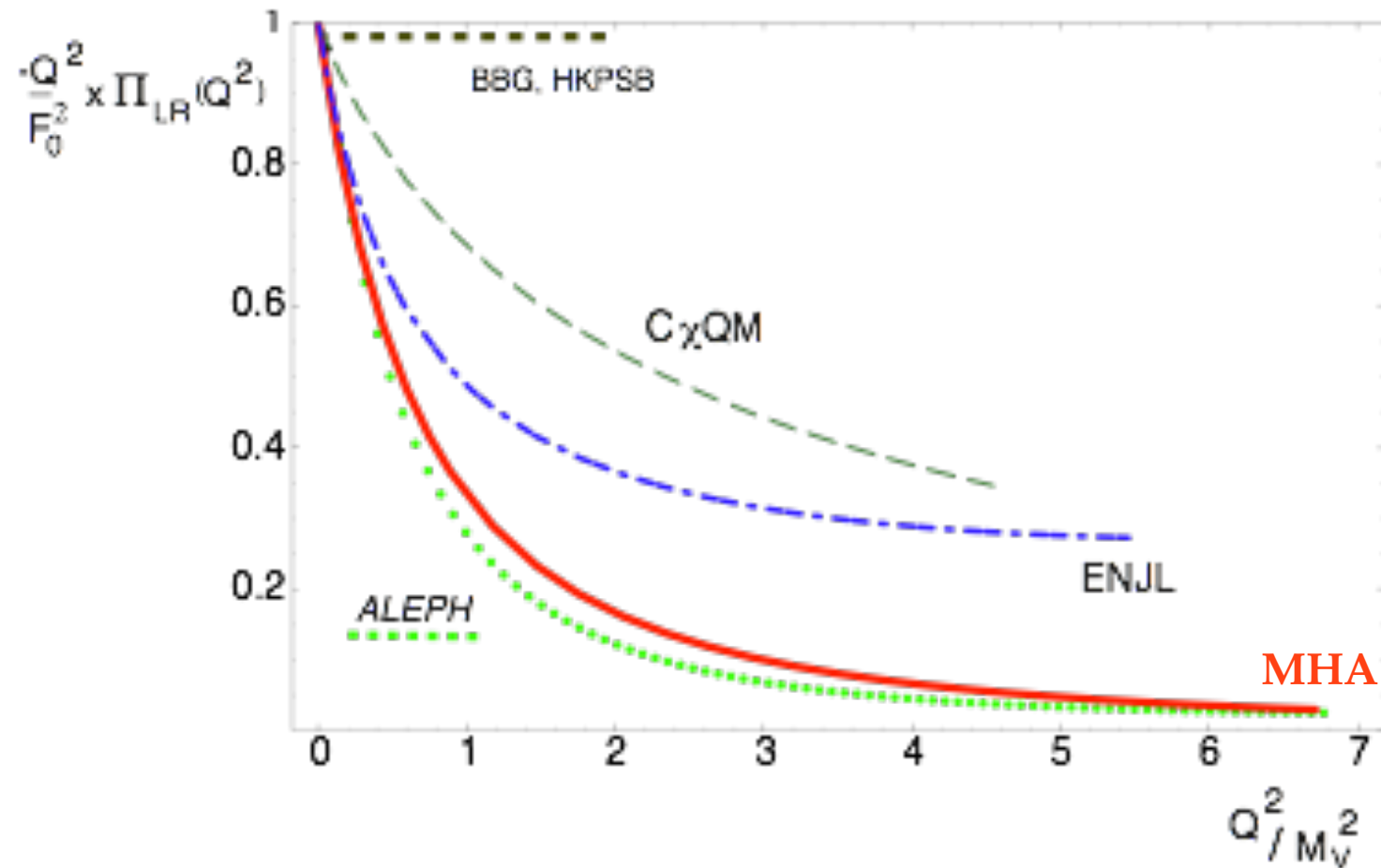

De Rafael

π	2π	3π	N_i
$\pi^+\gamma^*$ $\pi^0\gamma^* (S)$ $\pi^+\gamma\gamma$ <hr style="border-top: 1px dashed black;"/>	$\pi^+\pi^0\gamma^*$ $\pi^0\pi^0\gamma^* (L)$ $\pi^+\pi^0\gamma\gamma$ $\pi^+\pi^-\gamma\gamma (S)$ $\pi^+\pi^0\gamma$ $\pi^+\pi^-\gamma (S)$ $\pi^+\pi^-\gamma^* (L)$ $\pi^+\pi^-\gamma^* (S)$ $\pi^+\pi^0\gamma^*$	$\pi^+\pi^+\pi^-\gamma$ $\pi^+\pi^0\pi^0\gamma$ $\pi^+\pi^-\pi^0\gamma (L)$ $\pi^+\pi^-\pi^0\gamma (S)$	$\frac{N_{14}^r - N_{15}^r}{2N_{14}^r + N_{15}^r}$ <hr style="border-top: 1px dashed black;"/> $N_{14} - N_{15} - 2N_{18}$ <p style="text-align: center;">”</p> $N_{14} - N_{15} - N_{16} - N_{17}$ <p style="text-align: center;">”</p> <p style="text-align: center;">”</p> $7(N_{14}^r - N_{16}^r) + 5(N_{15}^r + N_{17}^r)$ $N_{14}^r - N_{15}^r - 3(N_{16}^r - N_{17}^r)$ $N_{14}^r - N_{15}^r - 3(N_{16}^r + N_{17}^r)$ $N_{14}^r + 2N_{15}^r - 3(N_{16}^r - N_{17}^r)$
	$\pi^+\pi^-\gamma (L)$ $\pi^+\pi^0\gamma$	$\pi^+\pi^-\pi^0\gamma (S)$ $\pi^+\pi^+\pi^-\gamma$ $\pi^+\pi^0\pi^0\gamma$ $\pi^+\pi^-\pi^0\gamma (S)$ $\pi^+\pi^-\pi^0\gamma (L)$	$N_{29} + N_{31}$ <p style="text-align: center;">”</p> $3N_{29} - N_{30}$ $5N_{29} - N_{30} + 2N_{31}$ $6N_{28} + 3N_{29} - 5N_{30}$

$$K^\pm \rightarrow \pi^\pm \gamma^* :$$

$$a_+ = -0.578 \pm 0.016 [3, 4]$$

$$K_S \rightarrow \pi^0 \gamma^* :$$

$$a_S = (1.06_{-0.21}^{+0.26} \pm 0.07) [5, 6]$$

$$K^\pm \rightarrow \pi^\pm \pi^0 \gamma :$$

$$X_E = (-24 \pm 4 \pm 4) \text{ GeV}^{-4} [7]$$

$$K^+ \rightarrow \pi^+ \gamma \gamma :$$

$$\hat{c} = 1.56 \pm 0.23 \pm 0.11 [8] .$$

$$\mathcal{N}_E^{(1)} \equiv N_{14}^r - N_{15}^r = \frac{3}{64\pi^2} \left(\frac{1}{3} - \frac{G_F}{G_8} a_+ - \frac{1}{3} \log \frac{\mu^2}{m_K m_\pi} \right) - 3L_9^r ;$$

$$\mathcal{N}_S \equiv 2N_{14}^r + N_{15}^r = \frac{3}{32\pi^2} \left(\frac{1}{3} + \frac{G_F}{G_8} a_S - \frac{1}{3} \log \frac{\mu^2}{m_K^2} \right) ;$$

$$\mathcal{N}_E^{(0)} \equiv N_{14}^r - N_{15}^r - N_{16}^r - N_{17}^r = -\frac{|\mathcal{M}_K| f_\pi}{2G_8} X_E ;$$

$$\mathcal{N}_0 \equiv N_{14}^r - N_{15}^r - 2N_{18}^r = \frac{3}{128\pi^2} \hat{c} - 3(L_9^r + L_{10}^r) ,$$

Decay mode	counterterm combination	expt. value
$K^\pm \rightarrow \pi^\pm \gamma^*$	$N_{14} - N_{15}$	$-0.0167(13)$
$K_S \rightarrow \pi^0 \gamma^*$	$2N_{14} + N_{15}$	$+0.016(4)$
$K^\pm \rightarrow \pi^\pm \pi^0 \gamma$	$N_{14} - N_{15} - N_{16} - N_{17}$	$+0.0022(7)$
$K^\pm \rightarrow \pi^\pm \gamma \gamma$	$N_{14} - N_{15} - 2N_{18}$	$-0.0017(32)$

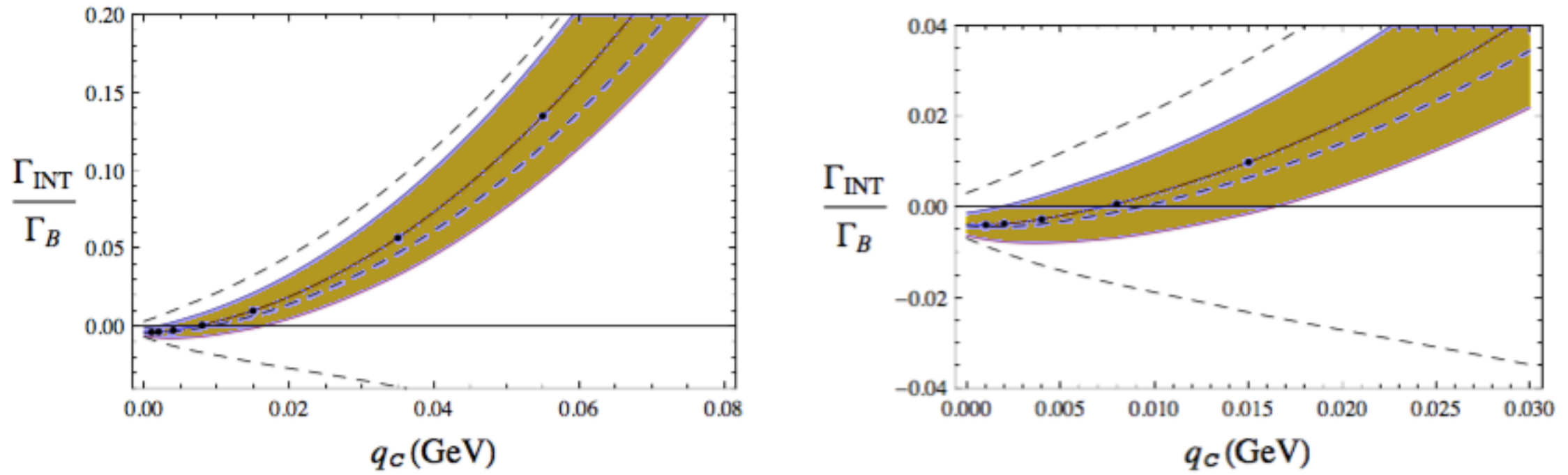

q cut in minimum dilepton

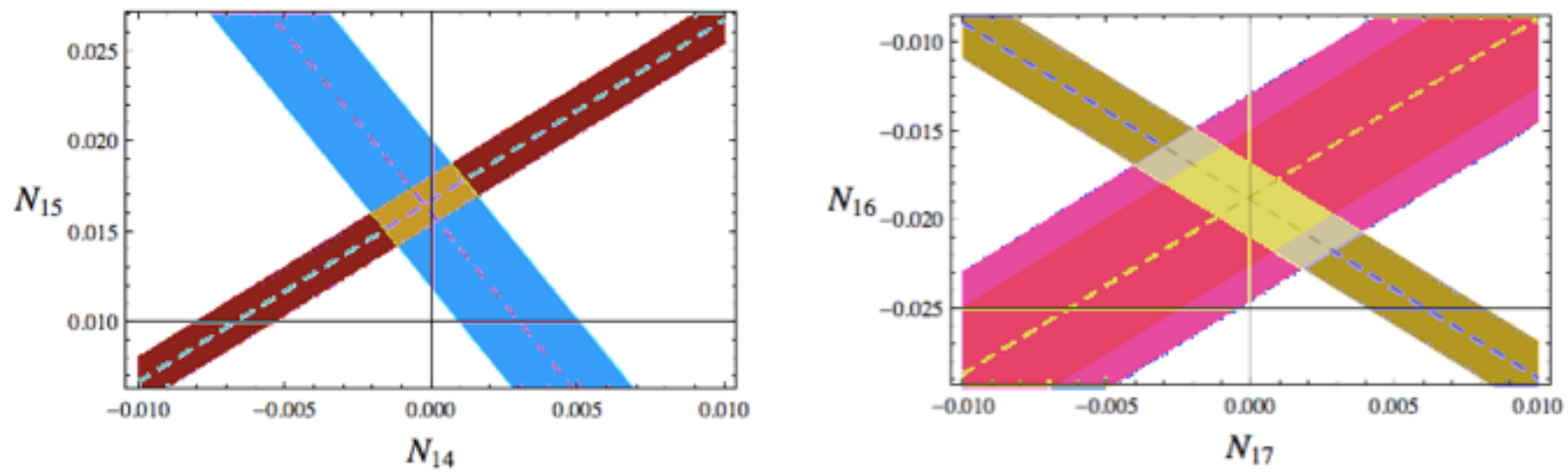
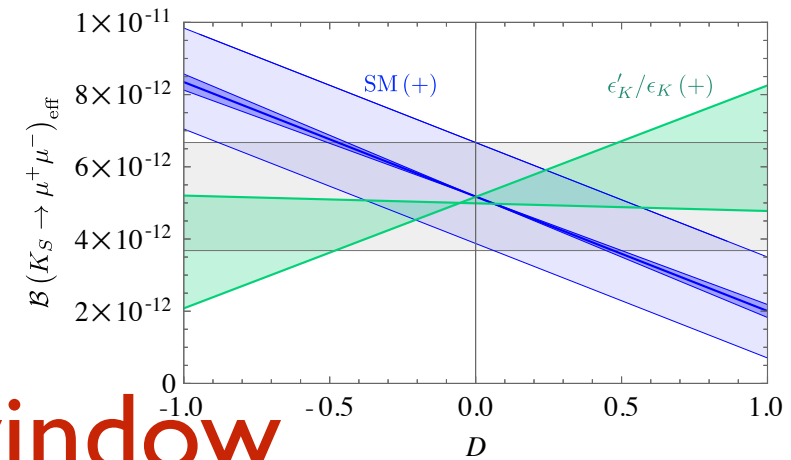

Figure 4: *Left panel: values of N_{14} and N_{15} as given by $K^\pm \rightarrow \pi^\pm \gamma^*$ (blue band) and $K_S \rightarrow \pi^0 \gamma^*$ (violet band). Right panel: values for N_{16} and N_{17} extracted from $K^\pm \rightarrow \pi^\pm \pi^0 \gamma$ (blue band) and $K^\pm \rightarrow \pi^\pm \pi^0 e^+ e^-$ (yellow band) measurements. The latter is an educated estimate (see main text).*

Conclusions

- Flavour anomalies: interplay with $K \rightarrow \pi \nu \nu$ but 10% measurement needed!

- LHCb: $K_S \rightarrow \mu \mu$ extraordinary result: interference effect!!! **Short distance window**



- weak chiral lagrangian
- LFUV in Kaons very useful
- Rich rare kaon program

Glino contribution to ϵ'_K/ϵ_K

[Kagan, Neubert, PRL '99, Grossman, Kagan, Neubert, JHEP '99]

- The main contribution to ϵ'_K/ϵ_K comes from gluino box loop
- In spite of QCD correction, gluino box diagrams **can** break strong isospin symmetry through mass difference between right-handed up and down squark masses, and they can contribute **ImA₂**, which is enhanced by small **ReA_{2,exp}** value

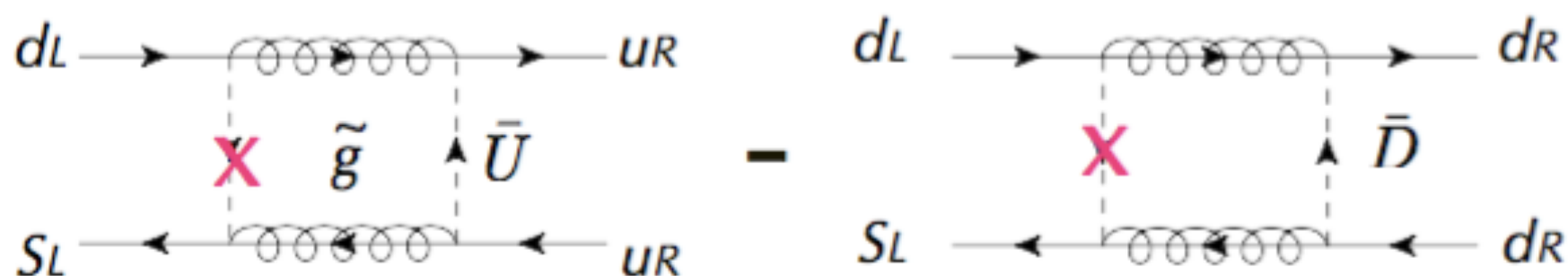

$m_{\bar{U}} \neq m_{\bar{D}}$ $\xrightarrow{\text{RGE}}$ EW penguin operators are generated at the low energy scale

with HMEs

\longrightarrow contribute to **ImA₂**



ϵ'_K can be solved

$$\frac{\epsilon'_K}{\epsilon_K} = \frac{1}{\sqrt{2}|\epsilon_K|_{\text{exp}}} \frac{\omega_{\text{exp}}}{(\text{Re}A_0)_{\text{exp}}} \left(-\text{Im}A_0 + \frac{1}{\omega_{\text{exp}}} \text{Im}A_2 \right) \quad \text{where} \quad \frac{1}{\omega} \equiv \frac{\text{Re}A_0}{\text{Re}A_2} = 22.46 \text{ (exp.)}$$

Main Constraint: ϵ_K ($\Delta S=2$, ID-CPV) cont.

- The leading contribution is given by $\overline{d_L} s_L \overline{d_R} s_R$

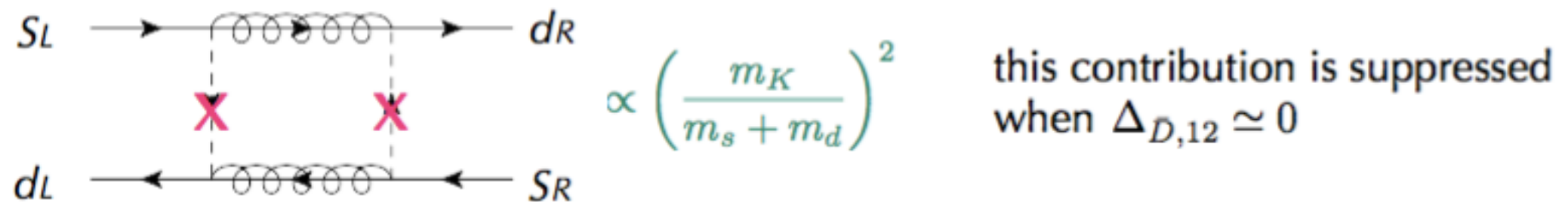

- The next contribution is given by $\overline{d_L} s_L \overline{d_L} s_L$

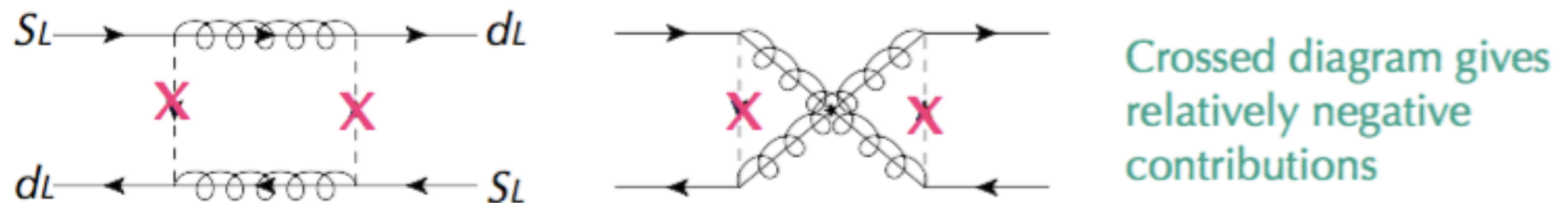

$m_{\tilde{g}} \simeq 1.5 m_{\tilde{q}}$: these contributions almost cancel out [Crivellin, Davidkov '10]

$m_{\tilde{g}} \gtrsim 1.5 m_{\tilde{q}}$: suppressed by heavy gluino mass

q_c (MeV)	$10^8 \times \Gamma_{\mathcal{B}}$	$\left[\frac{\Gamma_{\mathcal{E}}}{\Gamma_{\mathcal{B}}}\right]^{-1}$	$\left[\frac{\Gamma_{\text{INT}}}{\Gamma_{\mathcal{B}}}\right]_{(1,1,1)}^{-1}$	$\left[\frac{\Gamma_{\text{INT}}}{\Gamma_{\mathcal{B}}}\right]_{(1,0,1)}^{-1}$	$\left[\frac{\Gamma_{\text{INT}}}{\Gamma_{\mathcal{B}}}\right]_{(1,1,0)}^{-1}$	$\left[\frac{\Gamma_{\text{INT}}}{\Gamma_{\mathcal{B}}}\right]_{(0,1,1)}^{-1}$
$2m_l$	418.27	1100	-253	-225	-115	216
2	307.96	821	-265	-226	-98	159
4	194.74	529	-363	-264	-78	101
8	109.60	304	1587	-850	-59	58
15	56.12	161	102	156	-43	31
35	15.50	50	18	21	-26	11
55	5.62	22	7	9	-18	5
85	1.37	8	3	4	-13	3
100	0.67	5	2	3	-11	2
120	0.24	3	1.6	2	-10	1.4
140	0.04	2	1.0	1.1	-8	0.9
180	0.003	1	0.7	0.8	-7	0.7

Table 2: Branching ratios for the Bremsstrahlung and the relative weight of the electric and electric interference terms for different cuts in q , starting at q_{\min} (first row) and ending at 180 MeV. To highlight the role of the different counterterms, the last columns show how the interference term changes when they are switched off one at a time.

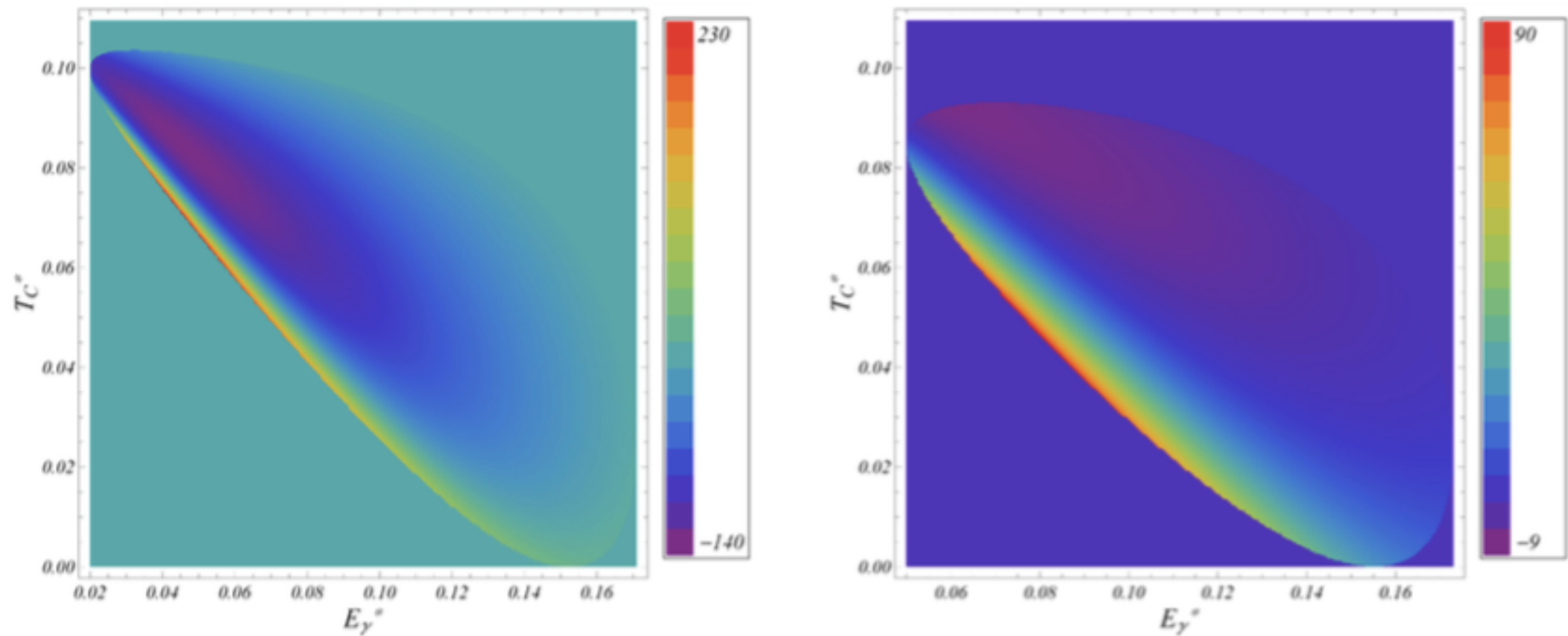
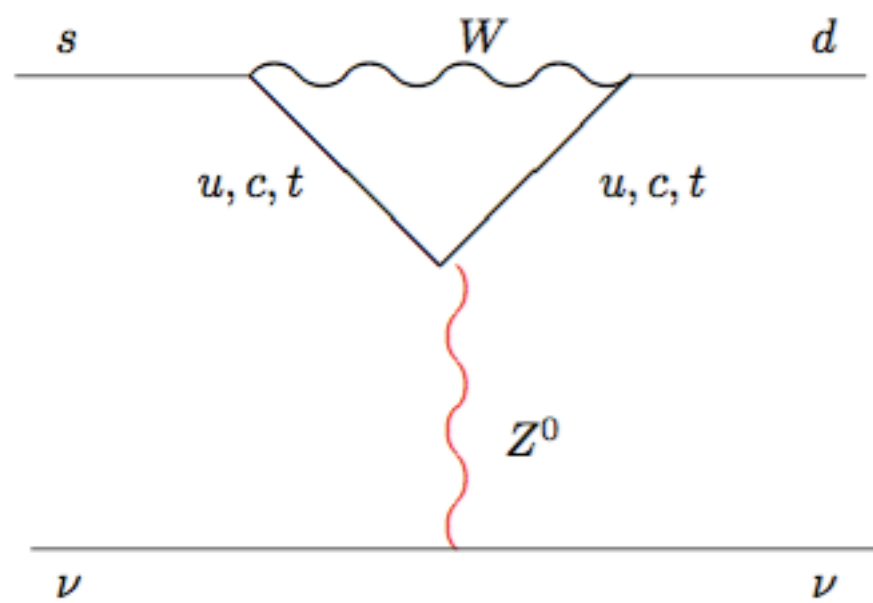
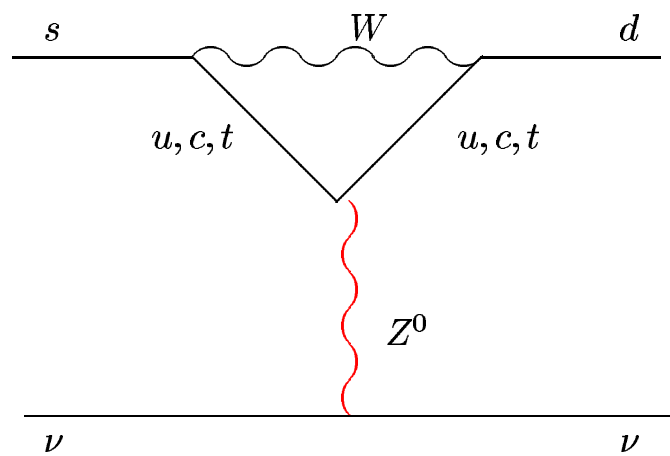

Figure 1: *Dalitz plots for the interference differential decay rate in the (E_γ, T_C) plane for $q = 20$ MeV (left panel) and $q = 50$ MeV (right panel). Numbers are given in units of $10^{-20} \text{ GeV}^{-1}$. The contour plot is 'spikier' the lower the q values are, a pattern mostly dictated by the structure of the Bremsstrahlung term.*

$$BR(K_S \rightarrow \pi^+ \pi^- e^+ e^-) = \underbrace{4.74 \cdot 10^{-5}}_{\text{Brems.}} + \underbrace{4.39 \cdot 10^{-8}}_{\text{Int.}} + \underbrace{1.33 \cdot 10^{-10}}_{\text{DE}}$$

Decay	Physics	Present limit (90% C.L.) / Result	NA62
$\pi^+\mu^+e^-$	LFV	1.3×10^{-11}	0.7×10^{-12}
$\pi^+\mu^-e^+$	LFV	5.2×10^{-10}	0.7×10^{-12}
$\pi^-\mu^+e^+$	LNV	5.0×10^{-10}	0.7×10^{-12}
$\pi^-e^+e^+$	LNV	6.4×10^{-10}	2×10^{-12}
$\pi^-\mu^+\mu^+$	LNV	1.1×10^{-9}	0.4×10^{-12}
$\mu^-e^+e^+$	LNV/LFV	2.0×10^{-8}	4×10^{-12}
$e^-e^+\mu^+\mu^+$	LNV	No data	10^{-12}
$\pi^+\chi^0$	New Particle	$5.9 \times 10^{-11} m_{\chi^0} = 0$	10^{-12}
$\pi^+\chi\chi$	New Particle	-	10^{-12}
$\pi^+\pi^+e^-\nu$	$\Delta S \neq \Delta Q$	1.2×10^{-8}	10^{-11}
$\pi^+\pi^+\mu^-\nu$	$\Delta S \neq \Delta Q$	3.0×10^{-6}	10^{-11}
$\pi^+\gamma$	Angular Mom.	2.3×10^{-9}	10^{-12}
$\mu^+\nu_h, \nu_h \rightarrow \nu\gamma$	Heavy neutrino	Limits up to $m_{\nu_h} = 350 \text{ MeV}$	
R_K	LU	$(2.488 \pm 0.010) \times 10^{-5}$	$> \times 2$ better
$\pi^+\gamma\gamma$	χ PT	< 500 events	10^5 events
$\pi^0\pi^0e^+\nu$	χ PT	66000 events	$O(10^6)$
$\pi^0\pi^0\mu^+\nu$	χ PT	-	$O(10^6)$



Back up

CP violation in $K \rightarrow 2\pi$

$$A(K_L \rightarrow \pi^+ \pi^-) \propto \underline{\epsilon + \epsilon'}$$

$$\epsilon \sim \mathcal{O}(10^{-3})$$

Christenson et al 64

$$\epsilon' \sim \mathcal{O}(10^{-6})$$

CERN NA31, Fermilab KTeV

$$A(K_L \rightarrow \pi^0 \pi^0) \propto \underline{\epsilon - 2\epsilon'}$$

$$H_{\Delta S=2}$$

Indirect CP violation

Kaon oscillation

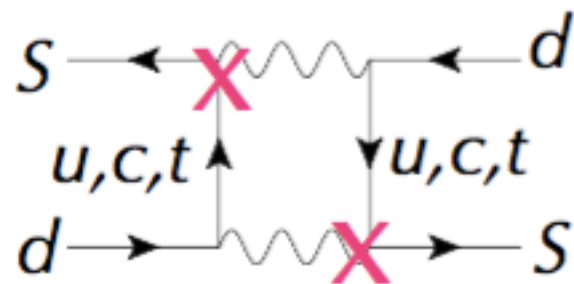

$$H_{\Delta S=1}$$

Direct CP Violation

Penguin

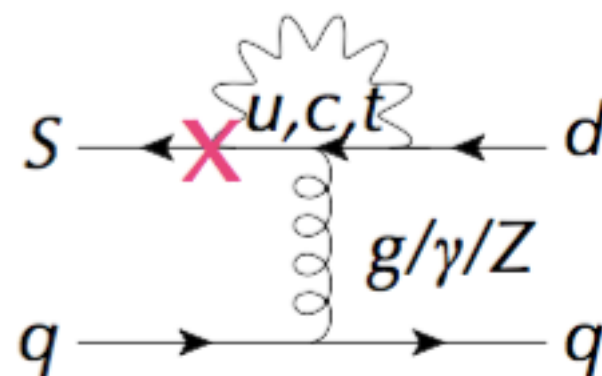

$$\frac{\epsilon'_K}{\epsilon_K} = \frac{1}{\sqrt{2}|\epsilon_K|_{\text{exp}}} \frac{\omega_{\text{exp}}}{(\text{Re}A_0)_{\text{exp}}} \left(-\text{Im}A_0 + \frac{1}{\omega_{\text{exp}}} \text{Im}A_2 \right) \quad \text{where } \frac{1}{\omega} \equiv \frac{\text{Re}A_0}{\text{Re}A_2} = 22.46 \text{ (exp.)}$$

gluon
penguin
 Q_6

EW
penguin
 Q_8

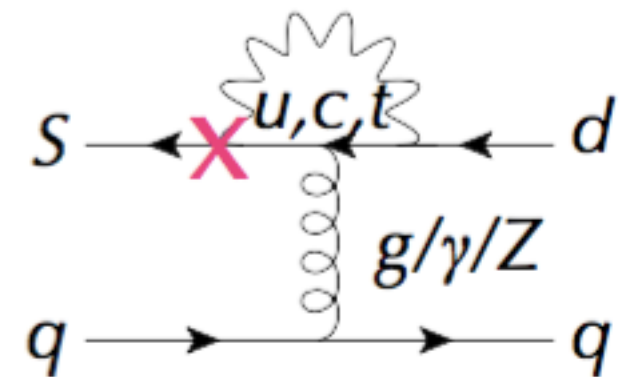

$\langle O_6 \rangle$ and $\langle O_8 \rangle$ have chiral enhancement factor

$$\langle Q_6(\mu) \rangle_0 = -4 \left[\frac{m_K^2}{m_s(\mu) + m_d(\mu)} \right]^2 (F_K - F_\pi) \underline{B_6^{(1/2)}}$$

$$\langle Q_8(\mu) \rangle_2 = \sqrt{2} \left[\frac{m_K^2}{m_s(\mu) + m_d(\mu)} \right]^2 F_\pi \underline{B_8^{(3/2)}}$$

**New lattice
result 2015**

$K \rightarrow \pi \nu \bar{\nu}$

Why we need to the experiments KOTO and NA62

$$A(s \rightarrow d \nu \bar{\nu})_{\text{SM}} \sim \bar{s}_L \gamma_\mu d_L \quad \bar{\nu}_L \gamma^\mu \nu_L \times \left[\sum_{q=c,t} V_{qs}^* V_{qd} m_q^2 \right]$$

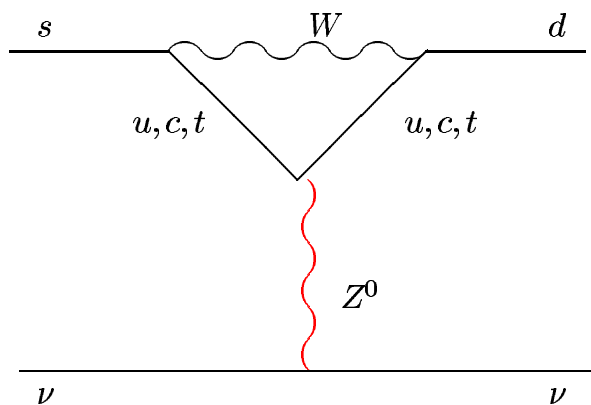

$$\sim [A^2 \lambda^5 (1 - \rho - i\eta) m_t^2 + \lambda m_c^2]$$

SM

$$\underbrace{V - A \otimes V - A}_{\Downarrow}$$

Littenberg

$$\Gamma(K_L \rightarrow \pi^0 \nu \bar{\nu})$$

$$\left\{ \begin{array}{l} \text{CP violating} \\ \Rightarrow J = A^2 \lambda^6 \eta \\ \text{Only } \underline{top} \end{array} \right.$$

SM

$$K^+ \rightarrow \pi^+ \nu \bar{\nu}$$

Misiak, Urban; Buras, Buchalla; Brod, Gorbhan, Stamou'11, Straub

$$B(K^+) \sim \kappa_+ \left[\left(\frac{\text{Im}\lambda_t}{\lambda^5} X_t \right)^2 + \left(\frac{\text{Re}\lambda_c}{\lambda} (P_c + \delta P_{c,u}) + \frac{\text{Re}\lambda_t}{\lambda^5} X_t \right)^2 \right]$$

- κ_+ from K_{l3} $\lambda_q = V_{qd}^* V_{qs}$
- P_c : SD charm quark contribution (30% ± 2.5% to BR)
LD $\delta P_{c,u} \sim 4 \pm 2\%$
- $B(K^\pm) = (8.82 \pm 0.8 \pm 0.3) \times 10^{-11}$ first error parametric (V_{cb}),
second non-pert. QCD
- E949 $B(K^\pm) = (1.73^{+1.15}_{-1.05}) \times 10^{-10}$

K_L

$$B(K_L) = (3.14 \pm 0.17 \pm 0.06) \times 10^{-11} \text{ vs}$$

E391a $B(K_L) < 2.6 \times 10^{-8}$ at 90% C.L.

K_L Model-independent bound, based on $SU(2)$ properties dim-6 operators for $\bar{s}d\bar{\nu}\nu$ Grossman-Nir

$$B(K_L) \leq \frac{\tau_L}{\tau_+} \times B(K^\pm)_{\text{E949}} \leq 1.4 \times 10^{-9} \text{ at } 90\% \text{ C.L.}$$

$$K^+ \rightarrow \pi^+ e^+ e^-$$

$$K_S \rightarrow \pi^0 e^+ e^-$$

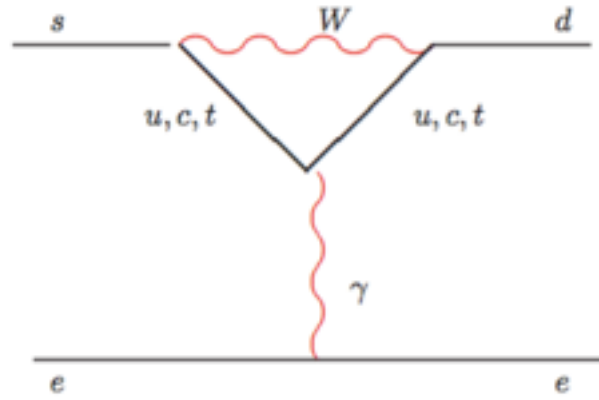

Short distance

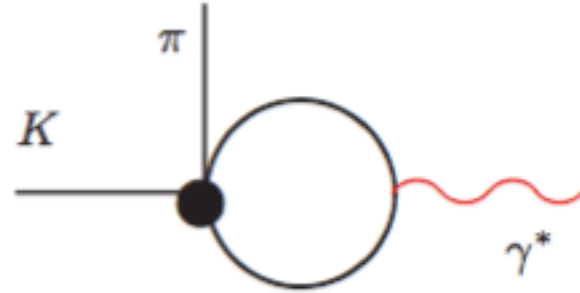

$O(p^4)$ ChPT
electrons and μ 's in the final state

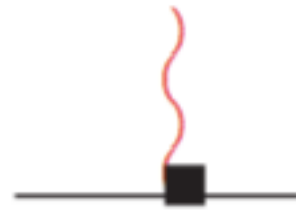

constant+ loop

Ecker, Pich, de Rafael

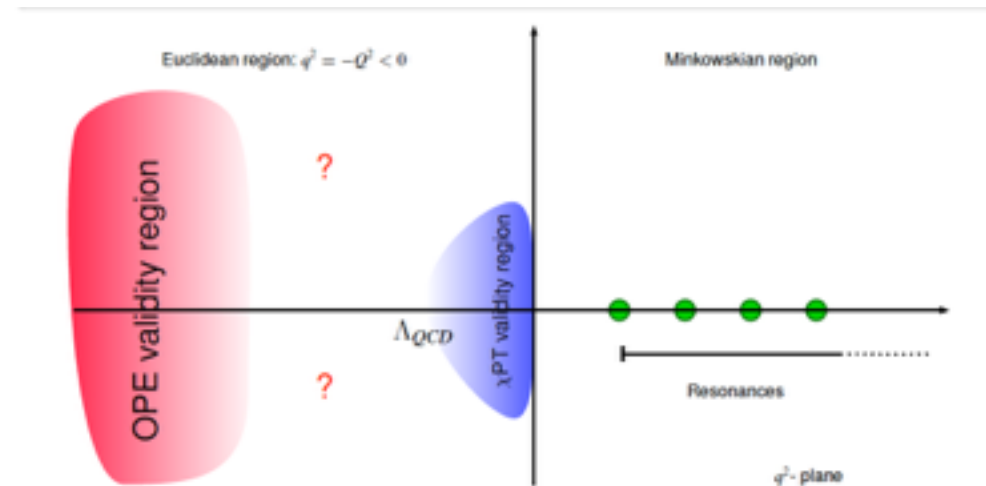

'97 Initial data inconsistency e and μ 's: LFV?

Collaboration with LHCb

	PDG	Prospects
$K_S \rightarrow \mu\mu$	$< 9 \times 10^{-9}$ at 90% CL	(LD) $(5.0 \pm 1.5) \cdot 10^{-12}$ NP $< 10^{-11}$
$K_S \rightarrow \mu\mu\mu\mu$	—	SM LD $\sim 2 \times 10^{-14}$
$K_S \rightarrow ee\mu\mu$	—	$\sim 10^{-11}$
$K_S \rightarrow eeee$	—	$\sim 10^{-10}$
$K_S \rightarrow \pi^0\mu\mu$	$(2.9 \pm 1.3) \cdot 10^{-9}$	$\sim 10^{-9}$
$K_S \rightarrow \pi^+\pi^-e^+e^-$	$(4.79 \pm 0.15) \cdot 10^{-5}$	SM LD $\sim 10^{-5}$
$K_S \rightarrow \pi^+\pi^-\mu^+\mu^-$	—	SM LD $\sim 10^{-14}$

Rare n Strange 2017: strange physics at LHCb

GD, Lewis Tunstall, Diego Martinez Santos, Veronika Chobanova,
 Xabier Cid Vidal, Francesco Dettori, Marc-Olivier Bettler,
 Teppei Kitahara, Kei Yamamoto

$$K^+ \rightarrow \pi^+ e^+ e^-$$

$$K_S \rightarrow \pi^0 e^+ e^-$$

- gauge+Lorentz inv. =>1 ff

$$i \int d^4x e^{iqx} \langle \pi(p) | T \{ J_{\text{elm}}^\mu(x) \mathcal{L}_{\Delta S=1}(0) \} | K(k) \rangle = \frac{W(z)}{(4\pi)^2} [z(k+p)^\mu - (1-r_\pi^2)q^\mu]$$

$$W^i = G_F m_K^2 (a_i + b_i z) + W_{\pi\pi}^i(z)$$

$$i = \pm, S$$

$$a_i, b_i \sim O(1),$$

$$z = \frac{q^2}{m_K^2}$$

- Observables $\Gamma(K^+ \rightarrow \pi^+ e^+ e^-)$, $\Gamma(K^+ \rightarrow \pi^+ \mu \bar{\mu})$, slopes

- $a_i \quad O(p^4) \quad a_+ \sim N_{14} - N_{15}, \quad a_S \sim 2N_{14} + N_{15}$

Ecker, Pich, de Rafael

- $b_i \quad O(p^6)$

G.D., Ecker, Isidori, Portoles

- a_+, b_+ in general not related to a_S, b_S

Recent lattice determinations Christ et al.

averaging flavour

$$a_+^{\text{exp.}} = -0.578 \pm 0.016$$

$$b_+^{\text{exp.}} = -0.779 \pm 0.066$$

LFUV: Kaons

$$\frac{\Gamma(K^+ \rightarrow \pi^+ \mu^+ \mu^-)}{\Gamma(K^+ \rightarrow \pi^+ e^+ e^-)}$$

SM

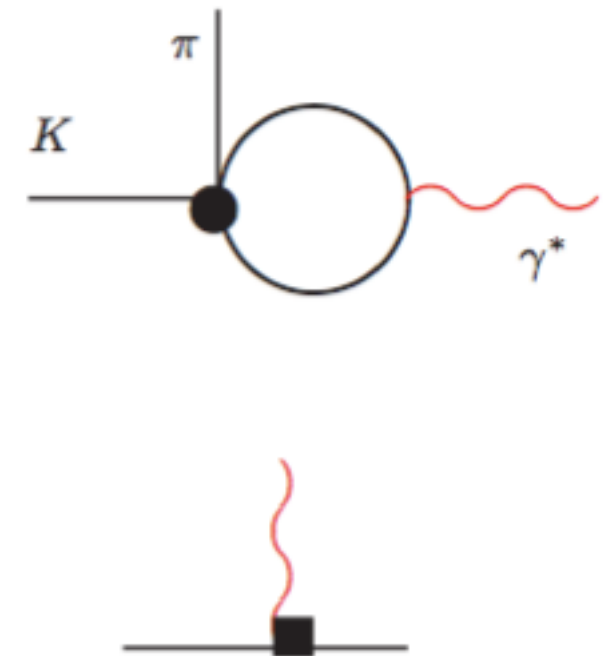
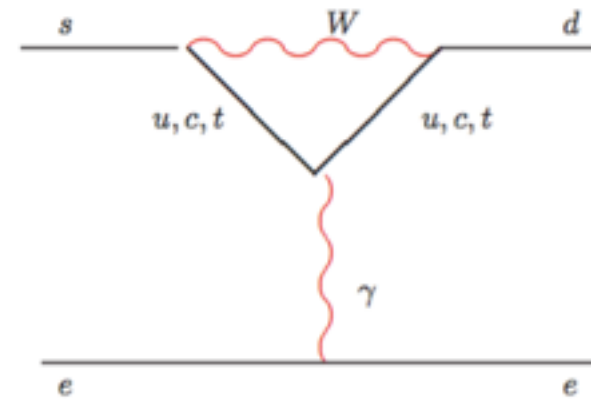

$$W^i = G_F m_K^2 (a_i + b_i z) + W_{\pi\pi}^i(z)$$

$$i = \pm, S$$

$$a_i, b_i \sim O(1), \quad z = \frac{q^2}{m_K^2}$$

LFUV: Kaons

Channel	a_+	b_+	Reference
ee	-0.587 ± 0.010	-0.655 ± 0.044	E865
ee	-0.578 ± 0.016	-0.779 ± 0.066	NA48/2
$\mu\mu$	-0.575 ± 0.039	-0.813 ± 0.145	NA48/2

$$a_+^{\text{NP}} = \frac{2\pi\sqrt{2}}{\alpha} V_{ud}V_{us}^* * C_{7V}^{\text{NP}}$$

$$C_{7V}^{\mu\mu} - C_{7V}^{ee} = \alpha \frac{a_+^{\mu\mu} - a_+^{ee}}{2\pi\sqrt{2}V_{ud}V_{us}^*} \xrightarrow{\text{MFV}} C_{9V}^{B,\mu\mu} - C_{9V}^{B,ee} = \alpha \frac{a_+^{\mu\mu} - a_+^{ee}}{2\pi\sqrt{2}V_{td}V_{ts}^*} = -19 \pm 79$$

NA62 PLEASE!!

High statistics: nominal # of decays 50 times greater than NA48/2

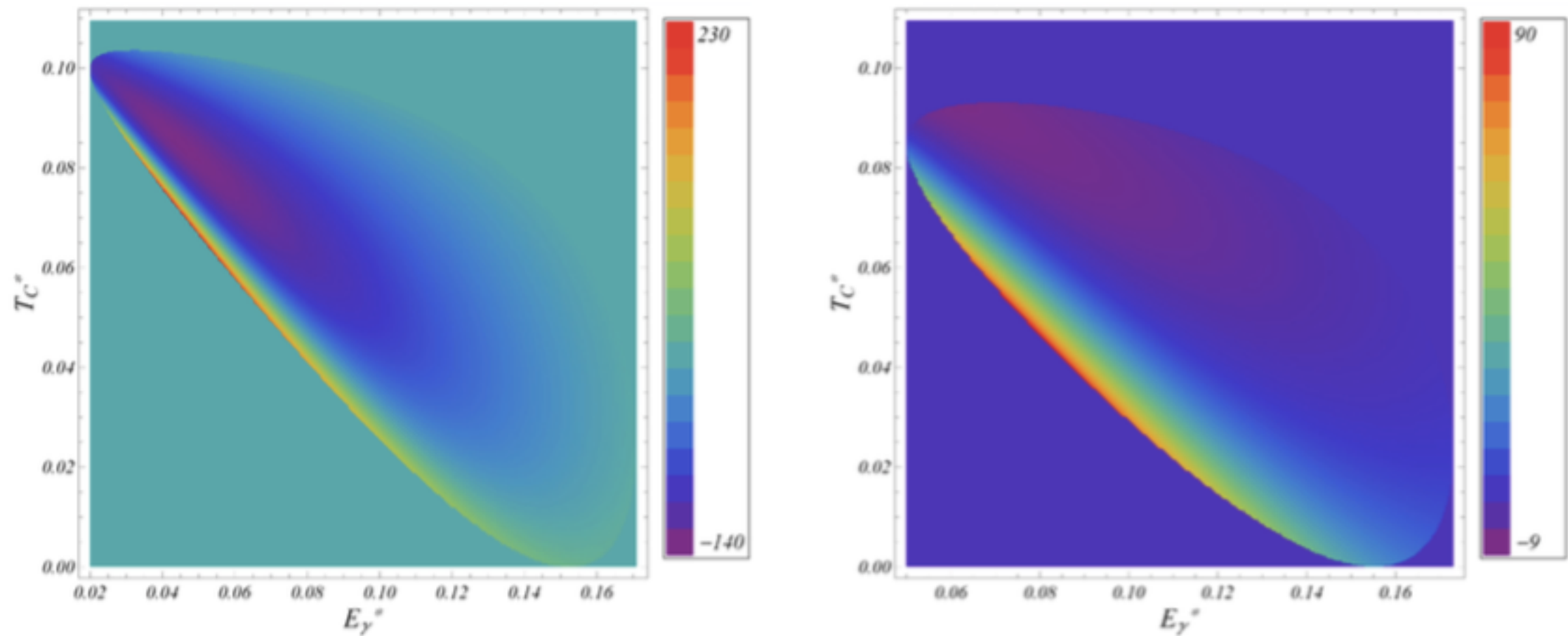

Figure 1: *Dalitz plots for the interference differential decay rate in the (E_γ, T_C) plane for $q = 20$ MeV (left panel) and $q = 50$ MeV (right panel). Numbers are given in units of $10^{-20} \text{ GeV}^{-1}$. The contour plot is 'spikier' the lower the q values are, a pattern mostly dictated by the structure of the Bremsstrahlung term.*

$$BR(K_S \rightarrow \pi^+ \pi^- e^+ e^-) = \underbrace{4.74 \cdot 10^{-5}}_{\text{Brems.}} + \underbrace{4.39 \cdot 10^{-8}}_{\text{Int.}} + \underbrace{1.33 \cdot 10^{-10}}_{\text{DE}}$$

q_c (MeV)	$10^8 \times \Gamma_{\mathcal{B}}$	$\left[\frac{\Gamma_{\mathcal{E}}}{\Gamma_{\mathcal{B}}}\right]^{-1}$	$\left[\frac{\Gamma_{\text{INT}}}{\Gamma_{\mathcal{B}}}\right]_{(1,1,1)}^{-1}$	$\left[\frac{\Gamma_{\text{INT}}}{\Gamma_{\mathcal{B}}}\right]_{(1,0,1)}^{-1}$	$\left[\frac{\Gamma_{\text{INT}}}{\Gamma_{\mathcal{B}}}\right]_{(1,1,0)}^{-1}$	$\left[\frac{\Gamma_{\text{INT}}}{\Gamma_{\mathcal{B}}}\right]_{(0,1,1)}^{-1}$
$2m_l$	418.27	1100	-253	-225	-115	216
2	307.96	821	-265	-226	-98	159
4	194.74	529	-363	-264	-78	101
8	109.60	304	1587	-850	-59	58
15	56.12	161	102	156	-43	31
35	15.50	50	18	21	-26	11
55	5.62	22	7	9	-18	5
85	1.37	8	3	4	-13	3
100	0.67	5	2	3	-11	2
120	0.24	3	1.6	2	-10	1.4
140	0.04	2	1.0	1.1	-8	0.9
180	0.003	1	0.7	0.8	-7	0.7

Table 2: Branching ratios for the Bremsstrahlung and the relative weight of the electric and electric interference terms for different cuts in q , starting at q_{\min} (first row) and ending at 180 MeV. To highlight the role of the different counterterms, the last columns show how the interference term changes when they are switched off one at a time.

QCD at work: Short Distance expansion for weak interaction

- Fermi lagrangian: description of the $\Delta S=1$ weak lagrangian, in particular the explanation of $\Delta I = 1/2$ rule

$$\frac{A(K^+ \rightarrow \pi^+ \pi^0)}{A(K_S \rightarrow \pi^+ \pi^-)} \sim \frac{1}{22}$$

- Wilson suggestion (Feynman) , short distance expansion

$$-\frac{G_F}{\sqrt{2}} V_{ud} V_{us}^* C_- (\bar{s}_L \gamma^\mu u_L) (\bar{u}_L \gamma_\mu d_L)$$

- Gaillard Lee, Altarelli Maiani: right direction but not fully understood (Long distance?)

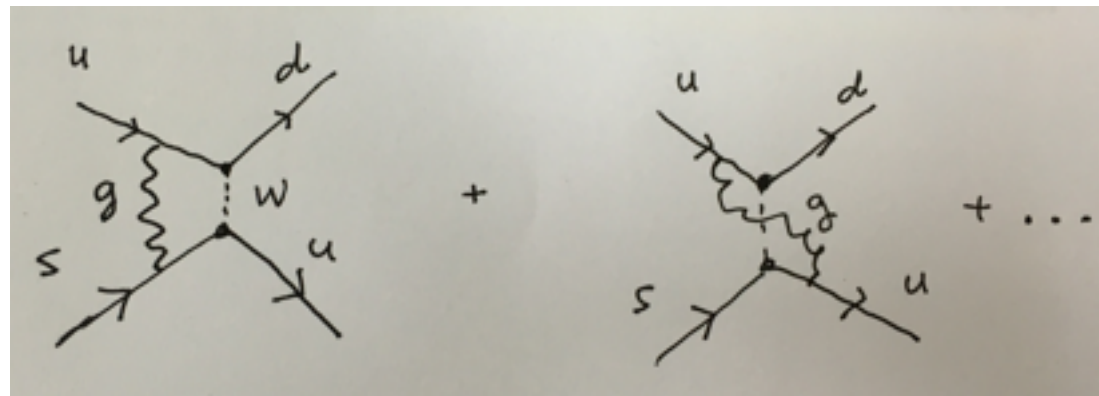

QCD at work, theoretical tools

- analytic calculation 't Hooft, large N_c (it explains basic phenomenological facts of QCD, i.e. Zweig's rule) many implications: Skyrme model, VMD, Maldacena
- G. Parisi, '80s lattice: can we predict from QCD the proton mass at 10% level?
- Precise calculation of low energy QCD?

Bardeen Buras Gerard approach to $K \rightarrow \pi\pi$

Also evaluated $\Delta S=2$ transitions, ϵ' (Buras) and $\pi^+ - \pi^0$ mass diff.

Main idea: phys. amplitudes scale independent

Match SD with LD with a precise prescription for CT

CHPT+Large N_c

$$H_{\text{eff}} = \sum_i C_i(\mu) Q_i(\mu)$$

SD

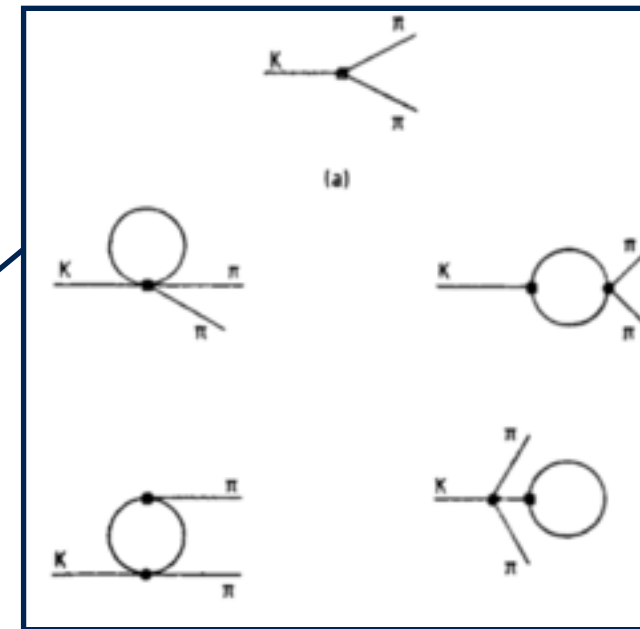

Can we test somewhere else
the Bardeen Buras Gerard
(BBG) approach?

Coluccio-Leskow, Estefania, GD, Greynat, David and Nath, Atanu

Matching a la BBG for $K^+ \rightarrow \pi^+ e^+ e^-$

Coluccio-Leskow, E. G.D , Greynat, D and Nath, A

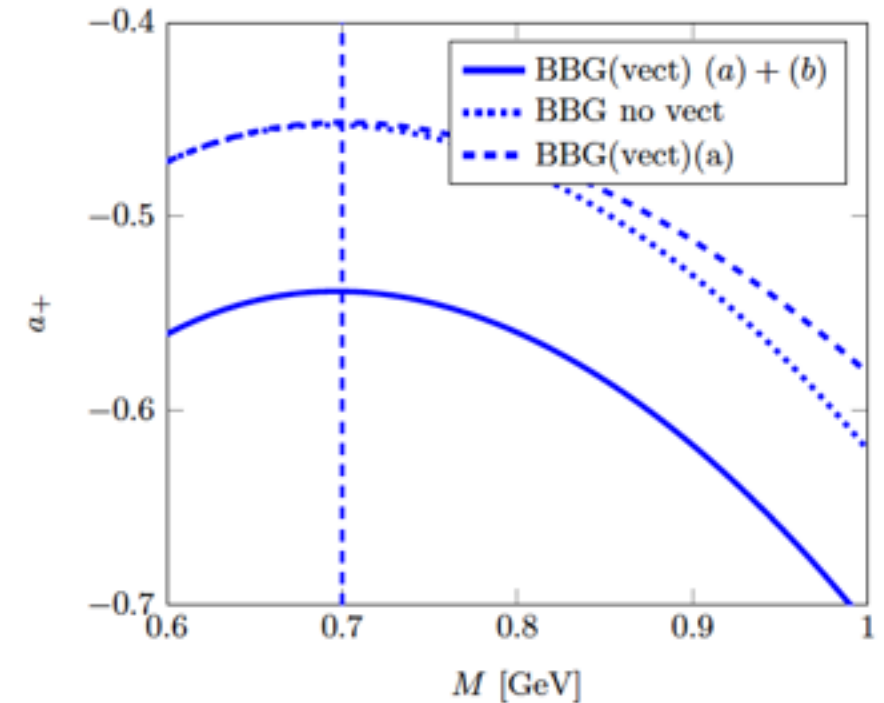
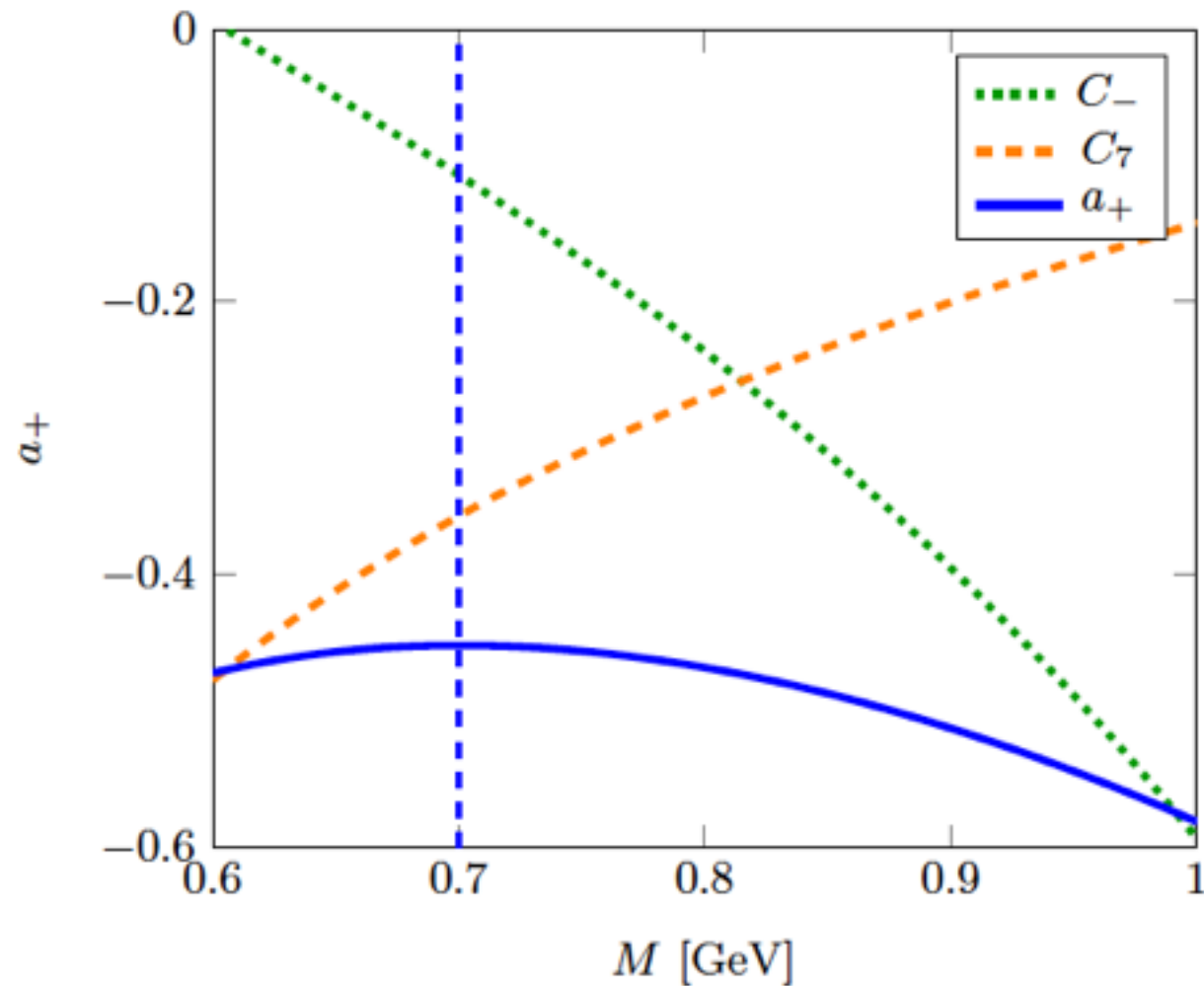
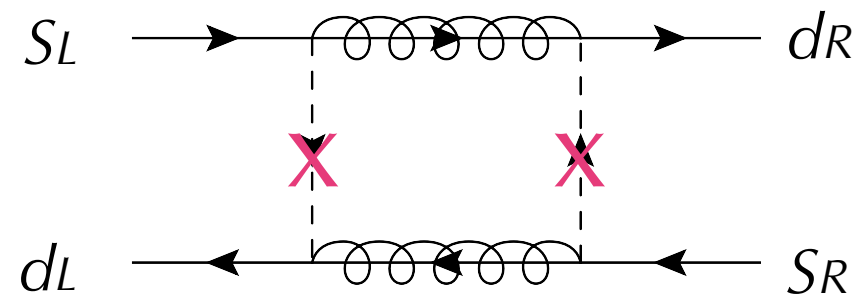

FIG. 5. a_+ as a function of M in the three different frameworks: 'BBG no vect.' where vectors are not included, 'BBG(vect)(a)' represents the contribution coming only from diagrams (a) in Fig. 4 and 'BBG(vect)(a)+(b)' is the case where both (a) and (b) diagrams were included. The vertical line indicates the value $M = 0.7$ GeV.

Main Constraint: ϵ_K ($\Delta S=2$, ID-CPV) cont.

- The leading contribution is given by $\overline{d_L s_L d_R s_R}$



$$\propto \left(\frac{m_K}{m_s + m_d} \right)^2$$

this contribution is suppressed when $\Delta_{\bar{D},12} \simeq 0$

- The next contribution is given by $\overline{d_L s_L d_L s_L}$

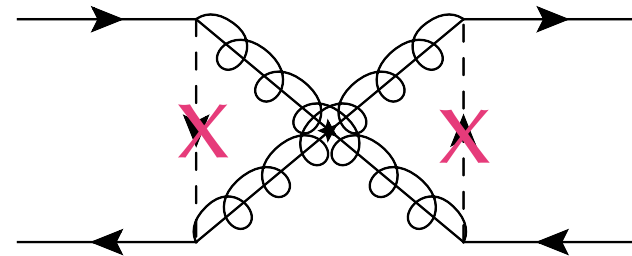
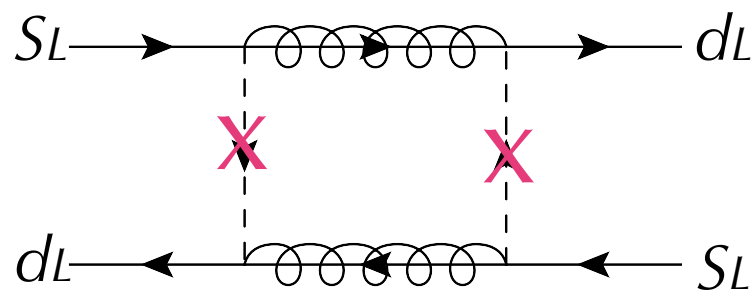

Crossed diagram gives **relatively negative** contributions

$m_{\tilde{g}} \simeq 1.5 m_{\tilde{q}}$: these contributions almost cancel out

[Crivellin, Davidkov '10]

$m_{\tilde{g}} \gtrsim 1.5 m_{\tilde{q}}$: suppressed by heavy gluing mass

Other interesting channels

$K_S \rightarrow \mu\mu\mu\mu$	—	SM LD	$\sim 2 \times 10^{-14}$
$K_S \rightarrow e e \mu \mu$	—		$\sim 10^{-11}$
$K_S \rightarrow e e e e$	—		$\sim 10^{-10}$

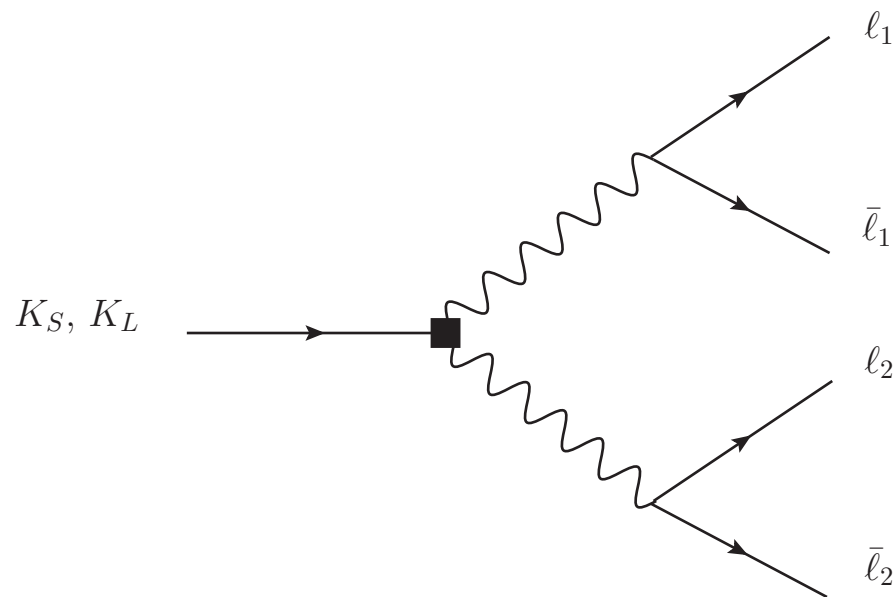

GD, Greynat, Vulvert