

Spartan-3A/3AN FPGA Starter Kit Board User Guide

UG334 (v1.1) June 19, 2008





Xilinx is disclosing this Document and Intellectual Property (hereinafter “the Design”) to you for use in the development of designs to operate on, or interface with Xilinx FPGAs. Except as stated herein, none of the Design may be copied, reproduced, distributed, republished, downloaded, displayed, posted, or transmitted in any form or by any means including, but not limited to, electronic, mechanical, photocopying, recording, or otherwise, without the prior written consent of Xilinx. Any unauthorized use of the Design may violate copyright laws, trademark laws, the laws of privacy and publicity, and communications regulations and statutes.

Xilinx does not assume any liability arising out of the application or use of the Design; nor does Xilinx convey any license under its patents, copyrights, or any rights of others. You are responsible for obtaining any rights you may require for your use or implementation of the Design. Xilinx reserves the right to make changes, at any time, to the Design as deemed desirable in the sole discretion of Xilinx. Xilinx assumes no obligation to correct any errors contained herein or to advise you of any correction if such be made. Xilinx will not assume any liability for the accuracy or correctness of any engineering or technical support or assistance provided to you in connection with the Design.

THE DESIGN IS PROVIDED “AS IS” WITH ALL FAULTS, AND THE ENTIRE RISK AS TO ITS FUNCTION AND IMPLEMENTATION IS WITH YOU. YOU ACKNOWLEDGE AND AGREE THAT YOU HAVE NOT RELIED ON ANY ORAL OR WRITTEN INFORMATION OR ADVICE, WHETHER GIVEN BY XILINX, OR ITS AGENTS OR EMPLOYEES. XILINX MAKES NO OTHER WARRANTIES, WHETHER EXPRESS, IMPLIED, OR STATUTORY, REGARDING THE DESIGN, INCLUDING ANY WARRANTIES OF MERCHANTABILITY, FITNESS FOR A PARTICULAR PURPOSE, TITLE, AND NONINFRINGEMENT OF THIRD-PARTY RIGHTS.

IN NO EVENT WILL XILINX BE LIABLE FOR ANY CONSEQUENTIAL, INDIRECT, EXEMPLARY, SPECIAL, OR INCIDENTAL DAMAGES, INCLUDING ANY LOST DATA AND LOST PROFITS, ARISING FROM OR RELATING TO YOUR USE OF THE DESIGN, EVEN IF YOU HAVE BEEN ADVISED OF THE POSSIBILITY OF SUCH DAMAGES. THE TOTAL CUMULATIVE LIABILITY OF XILINX IN CONNECTION WITH YOUR USE OF THE DESIGN, WHETHER IN CONTRACT OR TORT OR OTHERWISE, WILL IN NO EVENT EXCEED THE AMOUNT OF FEES PAID BY YOU TO XILINX HEREUNDER FOR USE OF THE DESIGN. YOU ACKNOWLEDGE THAT THE FEES, IF ANY, REFLECT THE ALLOCATION OF RISK SET FORTH IN THIS AGREEMENT AND THAT XILINX WOULD NOT MAKE AVAILABLE THE DESIGN TO YOU WITHOUT THESE LIMITATIONS OF LIABILITY.

The Design is not designed or intended for use in the development of on-line control equipment in hazardous environments requiring fail-safe controls, such as in the operation of nuclear facilities, aircraft navigation or communications systems, air traffic control, life support, or weapons systems (“High-Risk Applications”). Xilinx specifically disclaims any express or implied warranties of fitness for such High-Risk Applications. You represent that use of the Design in such High-Risk Applications is fully at your risk.

© 2007-2008 Xilinx, Inc. All rights reserved. XILINX, the Xilinx logo, and other designated brands included herein are trademarks of Xilinx, Inc. PCI Express is a registered trademark of PCI-SIG. All other trademarks are the property of their respective owners.

Revision History

The following table shows the revision history for this document.

Date	Version	Revision
05/28/07	1.0	Initial Xilinx release.
06/19/08	1.1	Added note that PS/2 port I/Os should always be set to LVCMOS33 with the PULLUP attribute set true when used. Updated UCF examples to match reference designs. Added recommendation for 1 MHz BPI configuration. Updated links.

Table of Contents

Preface: About This Guide

Acknowledgments	10
Guide Contents	10
Additional Resources	11

Chapter 1: Introduction and Overview

Getting Started	13
Operating the Default Demonstration Design	15
VGA Display	15
Rotary Knob/Push-Button Menu System	15
Select MultiBoot Configuration Image	16
Scroll or Rotate Graphic	17
Scroll or Scale Graphic	17
Restart AutoPilot, Speaker Volume Control	17
LCD Screen Control Option	18
Power-Saving Suspend Mode	18
RS-232 Serial Port Control Option	19
Key Components and Features	19
Design Trade-Offs	21
Configuration Methods Galore!	21
Voltages for all Applications	21
Spartan-3A/3AN FPGA Starter Kit Design Examples	21
Choose a Spartan-3 Generation Starter Kit Board for your Needs	22
Spartan-3A/3AN FPGA Features and Embedded Processing Functions	22
Other Spartan-3 Generation Development Boards	23
Spartan-3A and Spartan-3AN FPGAs	23
Related Resources	24

Chapter 2: Switches, Buttons, and Rotary Knob

Slide Switches	25
Locations and Labels	25
Operation	25
UCF Location Constraints	25
SUSPEND Switch	26
Push-Button Switches	27
Locations and Labels	27
Operation	27
PROG_B Push-Button Switch	28
UCF Location Constraints	28
Rotary Push-Button Switch	28
Locations and Labels	28
Operation	28
Push-Button Switch	28

Rotary Shaft Encoder	29
UCF Location Constraints	30
Discrete LEDs	30
Locations and Labels	30
Operation	31
UCF Location Constraints	31
Optional Discrete LEDs	31
AWAKE LED	32
INIT_B LED	32
UCF Location Constraints	32

Chapter 3: Clock Sources

Overview	33
Clock Connections	34
50 MHz On-Board Oscillator	34
Auxiliary Clock Oscillator Socket	34
SMA Clock Input or Output Connector	34
UCF Constraints	34
Location	34
Clock Period Constraints	35
Related Resources	35

Chapter 4: FPGA Configuration Options

Configuration Mode Jumpers	39
Xilinx Platform Flash Configuration PROM(s)	40
PROG Push-Button Switch	40
DONE Pin LED	41
Programming the FPGA or Platform Flash PROM via USB	41
Connecting the USB Cable	41
Platform Flash Programming Example	42

Chapter 5: Character LCD Screen

Overview	43
Character LCD Interface Signals	44
Voltage Compatibility	44
UCF Location Constraints	44
LCD Controller	45
Memory Map	45
DD RAM	45
CG ROM	46
CG RAM	47
Command Set	48
Disabled	49
Clear Display	49
Return Cursor Home	49
Entry Mode Set	49
Display On/Off	50

Cursor and Display Shift	50
Function Set	51
Set CG RAM Address	51
Set DD RAM Address	51
Read Busy Flag and Address	51
Write Data to CG RAM or DD RAM	51
Read Data from CG RAM or DD RAM	52
Operation	52
Four-Bit Data Interface	52
Transferring Eight-Bit Data over the Four-Bit Interface	53
Initializing the Display	53
Power-On Initialization	54
Display Configuration	54
Writing Data to the Display	54
Disabling the Unused LCD	55
Related Resources	55

Chapter 6: VGA Display Port

Signal Timing for a 60 Hz, 640x480 VGA Display	58
VGA Signal Timing	60
UCF Location Constraints	61
Related Resources	61

Chapter 7: RS-232 Serial Ports

Overview	63
UCF Location Constraints	64

Chapter 8: PS/2 Mouse/Keyboard Port

Keyboard	66
Mouse	68
Voltage Supply	69
Adding a Second PS/2 Port Using a Y-Splitter Cable	69
UCF Location Constraints	70
Related Resources	70

Chapter 9: Analog Capture Circuit

Digital Outputs from Analog Inputs	72
Programmable Pre-Amplifier	73
Interface	73
Programmable Gain	73
SPI Control Interface	74
UCF Location Constraints	75
Analog-to-Digital Converter (ADC)	75
Interface	75
SPI Control Interface	75
UCF Location Constraints	76
Connecting Analog Inputs	77

Related Resources	77
-------------------------	----

Chapter 10: Digital-to-Analog Converter (DAC)

SPI Communication	79
Interface Signals	80
SPI Communication Details	80
Communication Protocol	81
Specifying the DAC Output Voltage	82
UCF Location Constraints	82
Related Resources	82

Chapter 11: Parallel NOR Flash PROM

Flash Connections	84
Shared SPI Flash and Platform Flash Data Line	86
UCF Location Constraints	87
Address	87
Data	88
Control	88
Setting the FPGA Mode Select Pins	88
Creating and Programming Configuration Images for Parallel Flash	89
Related Resources	89

Chapter 12: SPI Serial Flash

SPI Flash PROM Select Jumpers (J1)	93
Shared SPI Flash and Platform Flash Data Line	94
Jumper Settings to Configure FPGA from Selected SPI Flash PROM	94
UCF Location Constraints	95
Creating and Programming Configuration Images for SPI Serial Flash	95
SPI Flash PROM Programming Options	95
Direct Programming Method	96
Using Embedded USB JTAG Programmer	96
Using a Separate JTAG Parallel Programming Cable (Optional)	97
Direct SPI Flash Programming Using iMPACT	98
Indirect Programming Method	101
Jumper Settings	101
Indirect SPI Flash Programming Using iMPACT	102
Related Resources	106

Chapter 13: DDR2 SDRAM

DDR2 SDRAM Connections	108
UCF Location Constraints	110
Address	110
Data	111
Control	111
Reserve FPGA V _{REF} Pins	112
Special Layout Recommendations	112
Related Resources	113

Chapter 14: 10/100 Ethernet Physical Layer Interface

Ethernet PHY Connections	116
MicroBlaze Ethernet IP Cores	117
UCF Location Constraints	118
Related Resources	118

Chapter 15: Expansion Connectors

Hirose 100-Pin FX2 Edge Connector (J17)	120
Expansion Connector Compatibility	120
Voltage Supplies to the Connector	120
Connector Pinout and FPGA Connections	121
FX2-Connector Compatible Boards	122
Mating Receptacle Connectors	122
UCF Location Constraints	123
Differential I/O Connectors	124
Using Differential Inputs	125
Using Differential Outputs	126
Differential Trace Layout Considerations	126
34-Conductor Cable Assemblies (2x17)	128
UCF Location Constraints	128
Six-Pin Accessory Headers	129
J18 Header	129
J19 Header	129
J20 Header	130
Digilent Peripheral Modules	130
UCF Location Constraints	131
Connectorless Debugging Port Landing Pads (J34)	131

Chapter 16: Miniature Stereo Audio Jack

Supported Audio Devices	133
FPGA Connections	134
UCF Location Constraints	134
Related Resources	134

Chapter 17: Voltage Supplies

Measuring Power Across Voltage Supply Jumpers	137
I²C Voltage Adjustment Interface	138
Possible Applications	138
Restoring Default Voltages	139
UCF Location Constraints	139
Related Resources	139

About This Guide

This user guide provides basic information on the Spartan[®]-3A/3AN Starter Kit board capabilities, functions, and design. It includes general information on how to use the various peripheral functions included on the board. For detailed reference designs, including VHDL or Verilog source code, please visit the following web link.

- **Spartan-3A/3AN FPGA Starter Kit Board Web Page**
<http://www.xilinx.com/s3astarter> and <http://www.xilinx.com/s3anstarter>

There are multiple versions of the Spartan-3A/3AN FPGA Starter Kit. This document describes the three kits that include the “Revision D” Spartan-3A/3AN FPGA Starter Kit Board, which is an updated version of the “Revision C” Spartan-3A FPGA Starter Kit Board. The following table describes the different kits.

Feature	Spartan-3AN Starter Kit	Spartan-3A DDR2 SDRAM Interface Development Kit	Spartan-3A Starter Kit, Revision D	Spartan-3A Starter Kit, Revision C
Part Number	HW-SPAR3AN-SK-UNI-G	HW-SPAR3ADDR2-DK-UNI-G	HW-SPAR3A-SK-UNI-G	
Device	XC3S700AN	XC3S700A		
Board Revision	Revision D			Revision C
DDR2 Memory	Supported with 133 MHz crystal oscillator in auxiliary socket			Requires board modification for improved performance
User Guide	UG334 (this document)			UG330
Web Page	www.xilinx.com/s3anstarter	www.xilinx.com/s3addr2	www.xilinx.com/s3astarter	

Almost all functionality is identical between the Revision C and Revision D boards, although the silkscreen changes make the two boards look different. The pictures used in this document are from the Revision D board. If you are using the original Revision C version of the board, refer to [UG330](#) for pictures and documentation. The following figure highlights where to find the board revision code on a Revision C board.

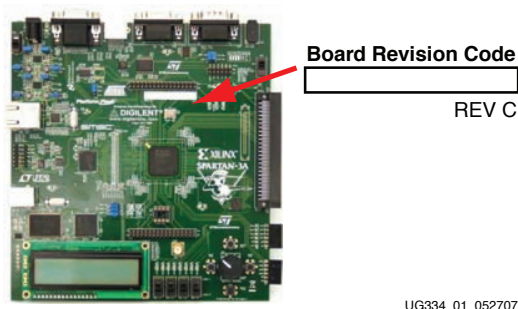

UG334_01_052707

Acknowledgments

Xilinx wishes to thank the following companies for their support of the Spartan-3A/3AN Starter Kit board:

- STMicroelectronics for the 32 Mbit parallel NOR Flash and 16 Mbit SPI serial Flash memories
- Atmel for the 16 Mbit SPI serial DataFlash memory
- Linear Technology for the SPI-compatible A/D and D/A converters and the programmable pre-amplifier
- SMSC for the 10/100 Ethernet PHY
- National Semiconductor for the four-rail voltage regulators that power the FPGA and all peripheral components
- Xilinx, Inc. Configuration Solutions for the XCF04S Platform Flash PROM and support for the embedded USB programmer

Guide Contents

This manual contains the following chapters:

- [Chapter 1, "Introduction and Overview,"](#) provides an overview of the key features of the Spartan-3A/3AN Starter Kit board.
- [Chapter 2, "Switches, Buttons, and Rotary Knob,"](#) defines the switches, buttons, and knobs present on the Spartan-3A/3AN Starter Kit board.
- [Chapter 3, "Clock Sources,"](#) describes the various clock sources available on the Spartan-3A/3AN Starter Kit board.
- [Chapter 4, "FPGA Configuration Options,"](#) describes the configuration options for the FPGA on the Spartan-3A/3AN Starter Kit board.
- [Chapter 5, "Character LCD Screen,"](#) describes the functionality of the character LCD screen.
- [Chapter 6, "VGA Display Port,"](#) describes the functionality of the VGA port.
- [Chapter 7, "RS-232 Serial Ports,"](#) describes the functionality of the RS-232 serial ports.
- [Chapter 8, "PS/2 Mouse/Keyboard Port,"](#) describes the functionality of the PS/2 mouse and keyboard port.
- [Chapter 10, "Digital-to-Analog Converter \(DAC\),"](#) describes the functionality of the D/A converter.

- [Chapter 9, “Analog Capture Circuit,”](#) describes the functionality of the A/D converter with a programmable gain pre-amplifier.
- [Chapter 11, “Parallel NOR Flash PROM,”](#) describes the functionality of the STMicroelectronics parallel NOR PROM.
- [Chapter 12, “SPI Serial Flash,”](#) describes the functionality of the SPI Serial Flash memory interface.
- [Chapter 13, “DDR2 SDRAM,”](#) describes the functionality of the DDR2 SDRAM memory interface.
- [Chapter 14, “10/100 Ethernet Physical Layer Interface,”](#) describes the functionality of the 10/100Base-T Ethernet physical layer interface.
- [Chapter 15, “Expansion Connectors,”](#) describes the various connectors available on the Spartan-3A/3AN Starter Kit board.
- [Chapter 16, “Miniature Stereo Audio Jack,”](#) describes the audio interface.
- [Chapter 17, “Voltage Supplies,”](#) describes the board’s power distribution system.

Additional Resources

To find additional documentation, see the Xilinx website at:

<http://www.xilinx.com/support/documentation/index.htm>

To search the Answer Database of silicon, software, and IP questions and answers, or to create a technical support WebCase, see the Xilinx website at:

<http://www.xilinx.com/support>.

Introduction and Overview

Thank you for purchasing the Xilinx Spartan[®]-3A/3AN FPGA Starter Kit. The board is invaluable to develop a Spartan-3A or Spartan-3AN FPGA application.

Getting Started

The Spartan-3A/3AN Starter Kit board is ready for use, right out of the box. The design stored in external Flash exercises the various I/O devices, such as the VGA display and serial ports. In addition it demonstrates new FPGA features, such as selectable MultiBoot and the power-saving Suspend mode.

To start using the board, follow the simple steps outlined in [Figure 1-1](#).

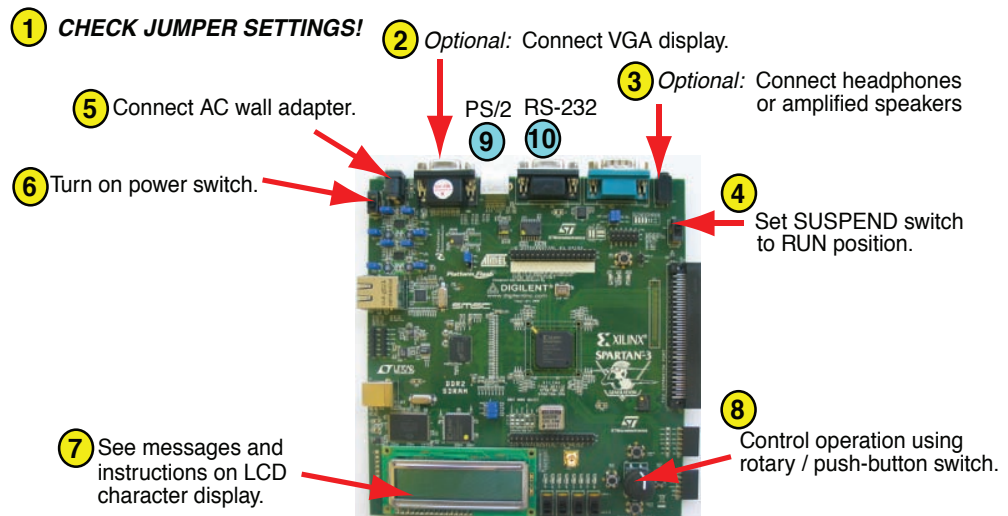

UG334_c1_01_052407

Figure 1-1: Powering Up the Starter Kit Board

1. Double-check the position of the board jumpers, as shown in [Figure 1-2, page 14](#). These settings are required for the demonstration design to configure correctly.
2. Optionally connect a VGA display device. The display device can be a CRT, a flat-panel, or even a projector.
3. Optionally connect headphones or amplified speakers to the audio jack.
4. Set the SUSPEND switch to the “RUN” position.
5. Connect the included AC adapter to wall power and also to the board. The AC adapter also includes attachments to support worldwide locals.

6. Turn on the power switch.
7. The character LCD and VGA display, if connected, display various informational messages and instructions. If an audio device is connected, the board offers words of welcome in a variety of languages.
8. Use the rotary/push-button switch to control various board functions.
9. Optionally connect a PS/2-style keyboard to support one of the included demonstrating designs.
10. Optionally connect a PC directly to the board using a standard 9-pin serial cable.

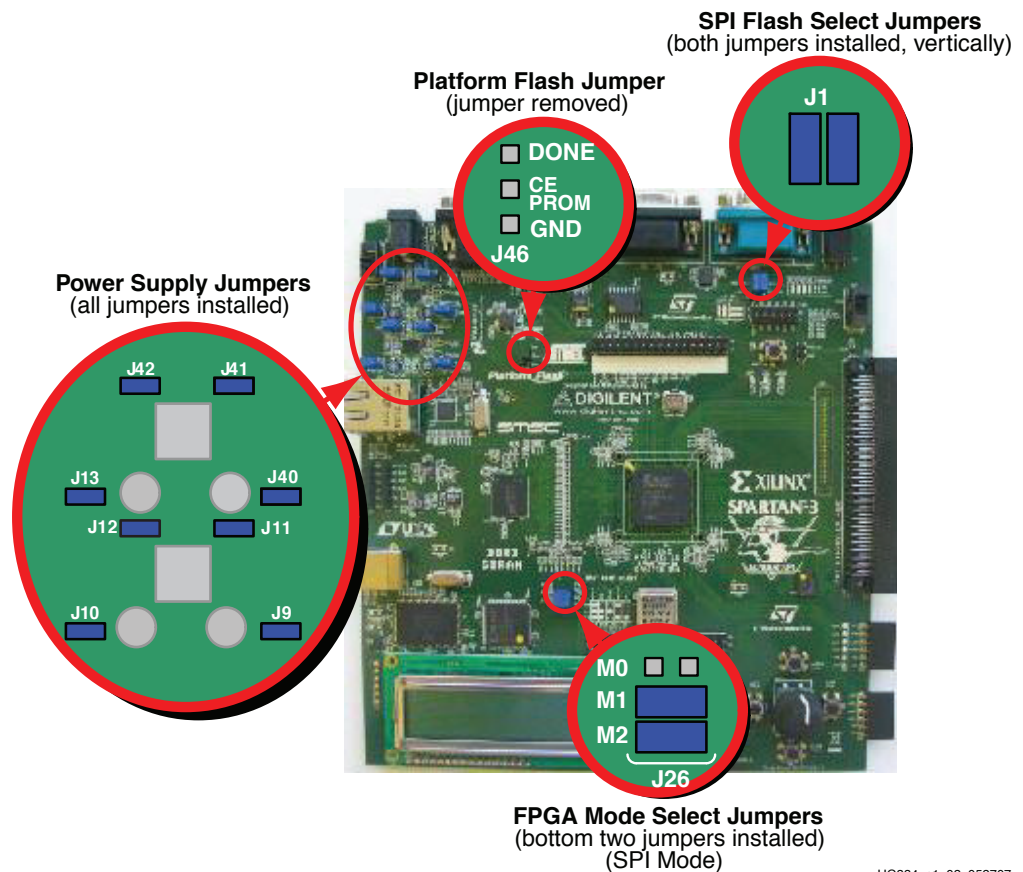

Figure 1-2: Default Jumper Settings for Starter Kit Board

For more information on the demonstration design, visit the Design Examples web page:

- **Spartan-3A/3AN FPGA Starter Kit Demo Design Overview**
www.xilinx.com/products/boards/s3astarter/reference_designs.htm#demo
- **Restoring the “Out of the Box” Flash Programming**
www.xilinx.com/products/boards/s3astarter/reference_designs.htm#out

Operating the Default Demonstration Design

The demonstration design programmed onto the Spartan-3A/3AN Starter Kit board provides various output information, depending on what I/O or display devices are connected. The VGA and audio ports provide the richest experience.

VGA Display

If a VGA display is connected to the board, then the Starter Kit board displays graphics similar to that shown in [Figure 1-3](#).

Until one of the four push buttons around the rotary knob ([Figure 2-5, page 27](#)) is pressed, the display automatically rotates a graphic image and zooms in and out around the image. This is called “AutoPilot” mode. A brief text overview describing the board appears along the left edge. Blue text at the bottom of the screen presents the menu system.

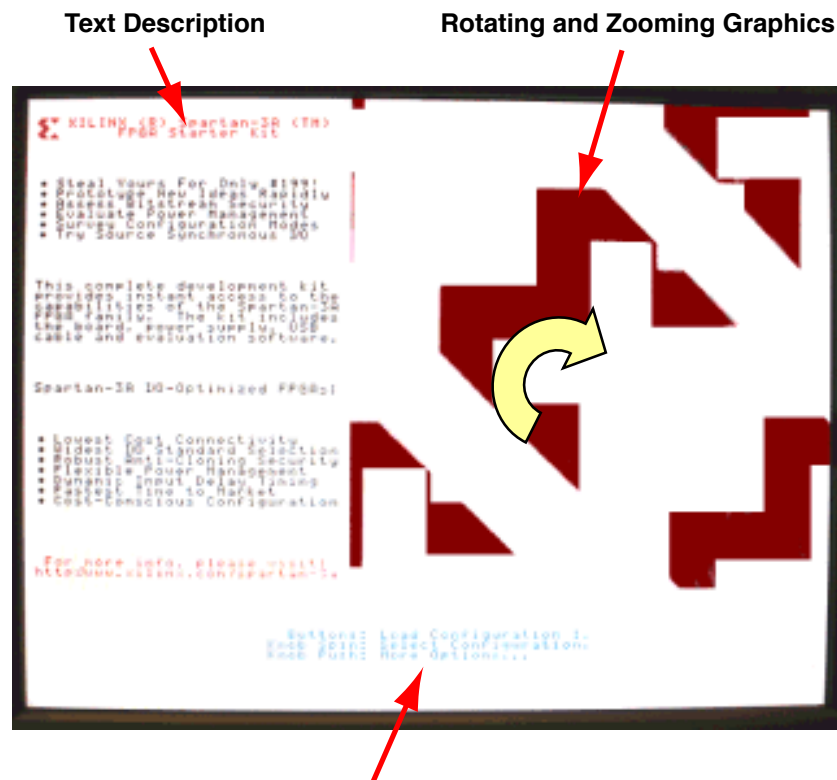

Rotary/Push-Button Menu System

UG330_c1_03_032207

Figure 1-3: Rotating/Zooming Graphics, Menu System Displayed on VGA Screen

Rotary Knob/Push-Button Menu System

The Spartan-3A/3AN Starter Kit board demonstration design uses the rotary knob and surrounding push-button switches, shown in [Figure 2-5, page 27](#), to implement a menu system. The menu display appears in blue text at the bottom of the VGA output. The menu functions are highlighted in [Table 1-1](#) and [Figure 1-4](#).

Table 1-1: Function of Each Menu Control

Press Knob	Rotate Knob	Press Push Button
Move to next menu selection, next mode.	Depends on current mode, as shown in Figure 1-4.	Depends on current mode, as shown in Figure 1-4.

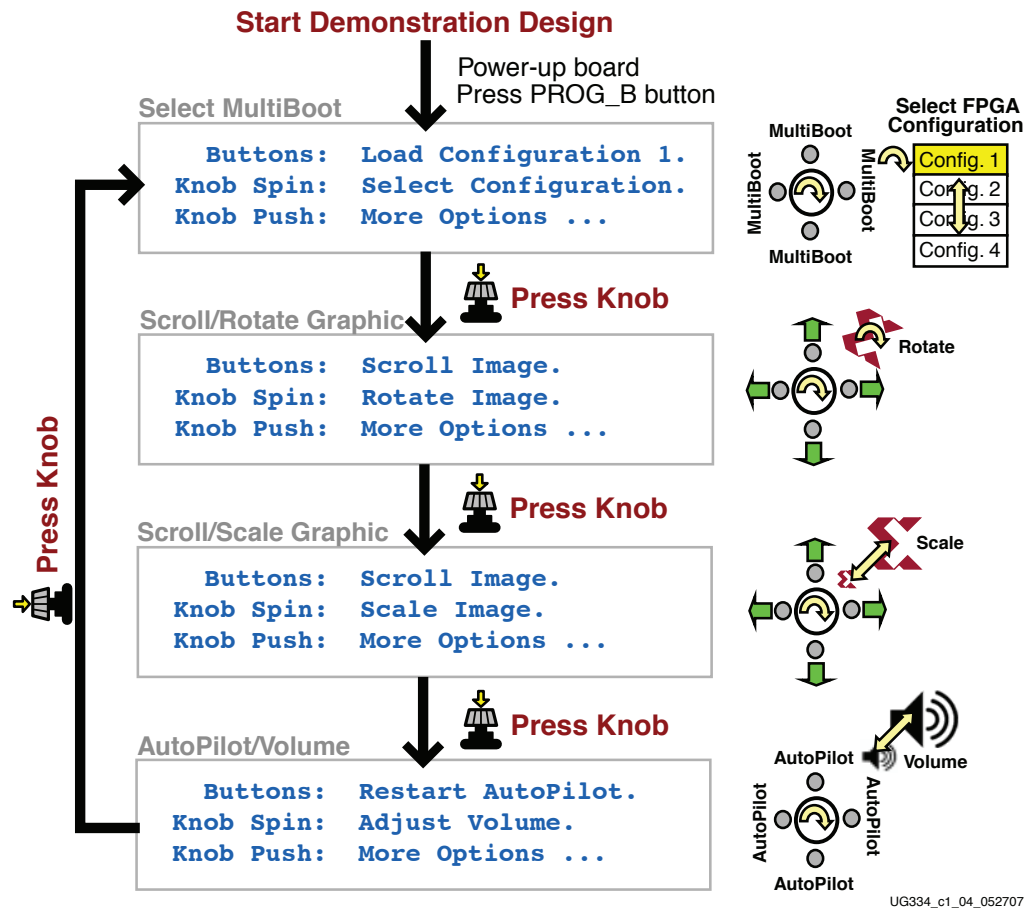

Figure 1-4: Rotary Knob/Push-Button Menu System

Select MultiBoot Configuration Image

Spartan-3A/3AN FPGAs support a selectable MultiBoot configuration interface. If the FPGA configures in one of its Master configuration modes, then the FPGA always loads the configuration image stored at address 0 in Flash at power-up, or whenever the PROG_B button is pressed.

Spin the rotary knob to select a new FPGA configuration image. The blue text at the bottom of the display updates with each click of the rotary knob. For example, the application displays “Buttons: Load Configuration x” where ‘x’ corresponds to the bitstream image listed in Table 1-2. Table 1-2 describes the bitstreams preloaded on the board.

After selecting the desired image, press one of the four push-button switches that surround the rotary knob. This action causes the FPGA to load the selected image from external Flash memory.

To change to the “Scroll or Rotate Graphic” mode, press the rotary knob.

Table 1-2: FPGA Configuration Bitstreams Preprogrammed on the Starter Kit Board

FPGA Configuration Bitstream	FPGA Application/Reference Design Example
0 (default)	Starter Kit board demonstration design. Loaded at power-up. www.xilinx.com/products/boards/s3astarter/reference_designs.htm#demo
1	Device DNA Reader: Reads the FPGA's unique Device ID value and displays it on the character LCD screen. www.xilinx.com/products/boards/s3astarter/reference_designs.htm#dna_reader
2	Fractal Generator: Computes fractal images in real time and displays on the VGA port. A user-contributed design by Matthias Alles. Rotate knob to zoom fractal image; press surrounding push buttons to scroll the image. www-user.rhrk.uni-kl.de/~alles/fpga/files.htm
3	ASCII Terminal: Implements a text terminal using an attached VGA display and PS/2 keyboard and will communicate with HyperTerminal on a PC via an RS-232 serial connection. Source included in www.xilinx.com/products/boards/s3astarter/reference_designs.htm#out .
4	STMicro M29DW323DT Parallel Flash Programmer: Communicates to a PC using HyperTerminal via an RS-232 serial connection. Programs, erases, and reads the STMicro M29DW323DT parallel Flash PROM on the Starter Kit board. www.xilinx.com/products/boards/s3astarter/reference_designs.htm#parallel_flash_programmer
Spartan-3AN FPGA	Internal Flash Paint Application: Use a mouse to create drawings and read or write them to In-System Flash. Loaded from internal SPI Flash in Spartan-3AN FPGA Starter Kit Board. Requires setting Mode pins as described in Table 4-1, page 39 for Internal Master SPI mode. <i>For Spartan-3AN Starter Kit Board only.</i> www.xilinx.com/products/boards/s3astarter/reference_designs.htm#paint .

Scroll or Rotate Graphic

In this mode, rotate the knob to rotate the graphic image clockwise or counterclockwise.

Use the four push-button switches to scroll the graphic image up, down, left, or right.

Press the rotary knob to change to the “[Scroll or Scale Graphic](#)” mode.

Scroll or Scale Graphic

In this mode, rotate the knob to scale the size of the graphic image, zooming in and out.

Use the four push-button switches to scroll the resulting graphic image up, down, left, or right.

Press the rotary knob to change to the “[Restart AutoPilot, Speaker Volume Control](#)” mode.

Restart AutoPilot, Speaker Volume Control

In this mode, rotate the knob to control the speaker output volume.

Press any of the four push-button switches to restart the AutoPilot function.

Press the rotary knob to change to the “[Select MultiBoot Configuration Image](#)” mode.

LCD Screen Control Option

While the demonstration design operates best with an attached VGA display, the on-board LCD screen tracks similar functionality, as shown in [Figure 1-5](#). If no VGA display is attached, then the “Scroll or Rotate Graphic”, “Scroll or Scale Graphic”, and “Restart AutoPilot, Speaker Volume Control” modes offer little to no functionality, the exception being the volume control assuming that a speaker is attached to the audio jack.

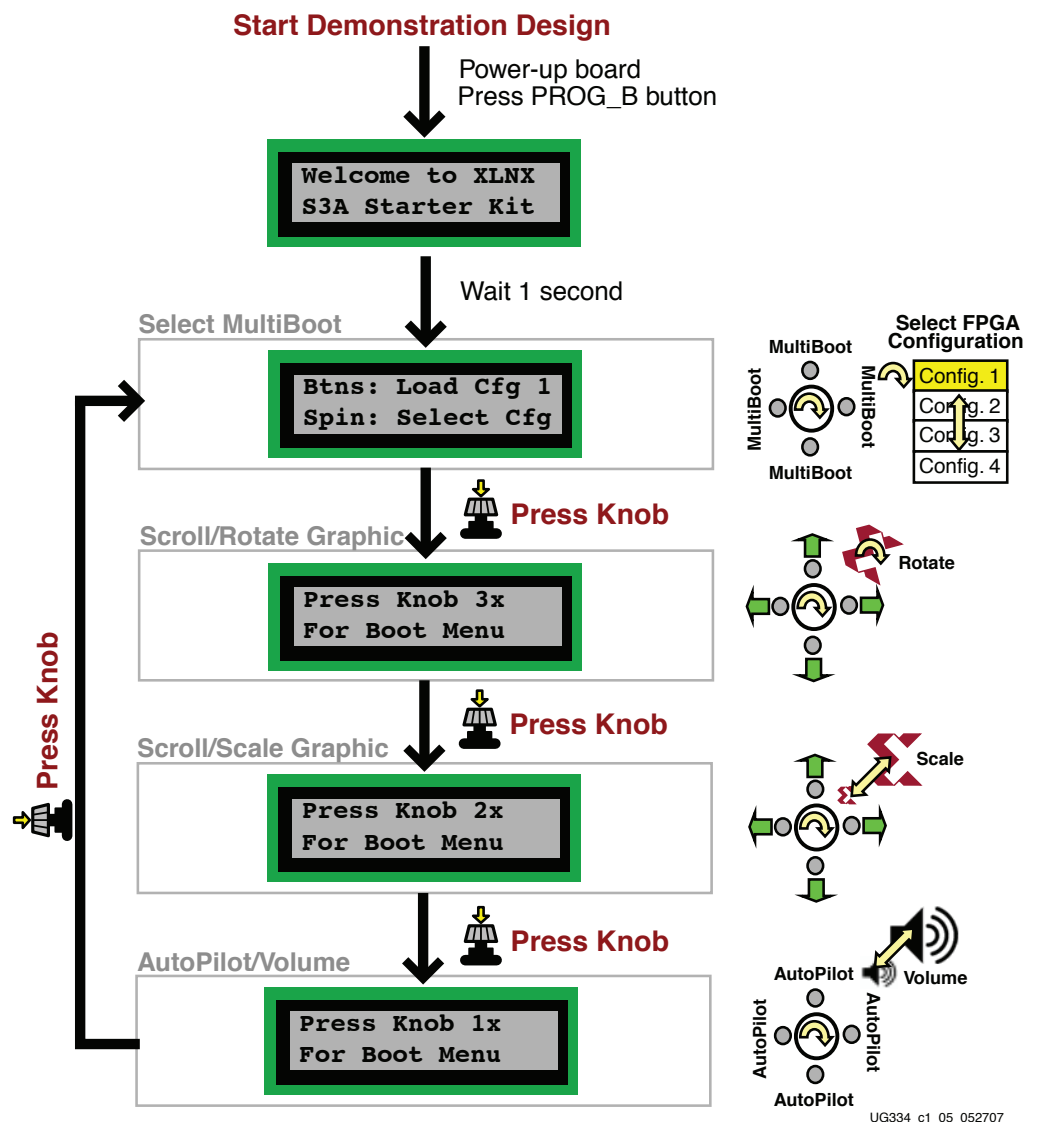

Figure 1-5: LCD Screen Output using Menu System

Power-Saving Suspend Mode

All of the preloaded FPGA configuration bitstreams have the power-saving Suspend mode enabled. Suspend mode reduces FPGA power consumption while preserving the present state of the FPGA application and the FPGA's configuration data. Set the SUSPEND switch to RUN or SUSPEND as described in “[SUSPEND Switch](#),” page 26.

Using one or two external multimeters, measure the corresponding difference in current consumption, as described in “[Measuring Power Across Voltage Supply Jumpers](#),” page 137.

Caution! Do not set the SUSPEND switch to “SUSPEND” while programming the parallel NOR Flash PROM using configuration bitstream #4, as described in [Table 1-2](#).

RS-232 Serial Port Control Option

Optionally, control the demonstration design using a serial port connection to a PC or workstation. On a PC, use the HyperTerminal program to communicate to the FPGA application, as shown in [Figure 1-6](#). Using a standard, straight-through 9-pin serial cable, connect the PC’s 9-pin RS-232 port to the board’s DCE connector (see [Figure 7-1](#), page 63).

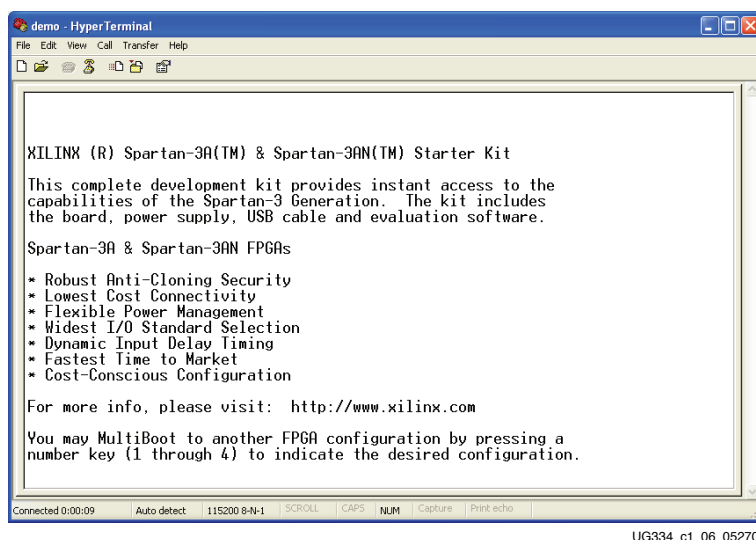

Figure 1-6: Use HyperTerminal and a Standard Serial Cable to Connect to Board

When the demonstration design begins operating, it transmits a message using the serial port.

Press a number key on the PC to load the associated MultiBoot bitstream listed in [Table 1-2](#).

Key Components and Features

The key features of the Spartan-3A FPGA Starter Kit board or the Spartan-3AN FPGA Starter Kit board are:

- **Spartan-3A FPGA Starter Kit Board:** Xilinx 700K-gate XC3S700A [Spartan-3A FPGA](#) in the Pb-free 484-ball BGA package (FGG484)
- **Spartan-3AN FPGA Starter Kit Board:** Xilinx 700K-gate XC3S700AN [Spartan-3AN nonvolatile FPGA](#) in the Pb-free 484-ball BGA package (FGG484)
 - ◆ Internal 8 Mbit In-System Flash memory
 - ◆ Store FPGA configuration bitstream or nonvolatile data
- 4 Mbit Xilinx [Platform Flash configuration PROM](#)
- 64 MByte (512 Mbit) of DDR2 SDRAM, 32Mx16 data interface
- 4 MByte (32 Mbit) of parallel NOR Flash

- ◆ FPGA configuration storage
- ◆ [MicroBlaze™](#) code storage/shadowing
- ◆ x8 or x16 data interface after configuration
- Two 16 Mbit SPI serial Flash
 - ◆ STMicroelectronics and Atmel DataFlash serial architectures
 - ◆ FPGA configuration storage
 - Supports single configuration bitstream or multiple MultiBoot configuration bitstreams
 - ◆ Nonvolatile data storage
 - ◆ MicroBlaze code shadowing
- Two-line, 16-character LCD screen
- PS/2 port
 - ◆ Supports PS/2-compatible mouse or keyboard
 - ◆ Supports both mouse and keyboard using a Y-splitter cable (not included)
- VGA display port, 12-bit color
- 10/100 Ethernet PHY (requires Ethernet MAC in FPGA)
- Two nine-pin RS-232 ports (DTE- and DCE-style)
- On-board USB-based programming solution
 - ◆ FPGA download/debug
 - ◆ SPI serial Flash in-system direct programming
- 50 MHz clock oscillator
- 8-pin DIP socket for second oscillator
- SMA connector for clock inputs or outputs
- 100-pin Hirose FX2 expansion connector with up to 43 FPGA user I/Os
 - ◆ Compatible with [Digilent FX2 add-on cards](#)
- High-speed differential I/O connectors
 - ◆ Receiver: Six data channels or five data channels plus clock
 - ◆ Transmitter: Six data channels or five data channels plus clock
 - ◆ Supports multiple differential I/O standards, including LVDS, RSDS, mini-LVDS
 - ◆ Also supports up to 24 single-ended I/O
 - ◆ Uses widely available 34-conductor cables
- Two six-pin expansion connectors for [Digilent Peripheral Modules](#)
- Four-output, SPI-based Digital-to-Analog Converter (DAC)
- Two-input, SPI-based Analog-to-Digital Converter (ADC) with programmable-gain pre-amplifier
- Stereo audio jack using digital I/O pins
- [ChipScope™](#) SoftTouch debugging port
- Rotary-encoder with push-button shaft
- Eight discrete LEDs
- Four slide switches
- Four push-button switches

Design Trade-Offs

A few system-level design trade-offs were required in order to provide the Spartan-3A/3AN Starter Kit board with the most functionality.

Configuration Methods Galore!

A typical FPGA application uses a single, nonvolatile memory to store configuration images. A typical Spartan-3AN nonvolatile FPGA application would not require any external memory. To demonstrate new Spartan-3A and Spartan-3AN FPGA capabilities, the starter kit board has four different configuration memory sources that all must function well together. The extra configuration functions make the starter kit board more complex than typical FPGA applications.

The starter kit board also includes an on-board USB-based JTAG programming interface. The on-chip circuitry simplifies the device programming experience. In typical applications, the JTAG programming hardware resides off-board or in a separate programming module, such as the Xilinx Platform USB cable.

Voltages for all Applications

The Spartan-3A/3AN FPGA typically operates with two supply rails, 1.2V and 3.3V. The Spartan-3A/3AN Starter Kit board showcases a quadruple-output regulator developed by National Semiconductor specifically to power Spartan-3 generation FPGAs. This regulator is sufficient for most standalone FPGA applications.

Spartan-3A/3AN FPGA Starter Kit Design Examples

Visit the Spartan-3A/3AN FPGA Starter Kit Design Examples web page to download and use the latest applications that specifically target the starter kit board:

- **Spartan-3A/3AN Starter Kit Design Examples Web Page**
www.xilinx.com/products/boards/s3astarter/reference_designs.htm

The list of designs is ever growing and the applications are often updated to the latest software releases. The following list provides a sample of design examples:

- **Spartan-3A/3AN Starter Kit Demo Design Overview**
www.xilinx.com/products/boards/s3astarter/reference_designs.htm#demo

This describes the out-of-the box demo design shipped with the board. Includes how to set up and operate the demonstration, evaluate MultiBoot and Suspend, and provides demo technical details.

- **Restoring the “Out of the Box” Flash Programming**
www.xilinx.com/products/boards/s3astarter/reference_designs.htm#out

Provides a short overview of what the starter kit board does “out of the box” and includes instructions on how to restore the board to the original “out of the box” state. The ZIP file includes the “golden” MCS files that are pre-programmed into Flash memory before the board is shipped. The PDF file contains instructions for restoring the board to its original settings using these MCS files in case any of the configuration memories were overwritten during normal use.

- **Spartan-3A/3AN Starter Kit Board Verification Design**
www.xilinx.com/products/boards/s3astarter/reference_designs.htm#test
This example includes the board test specification and the board test design. This design was used during initial board verification and some functions are used during production test. It is provided to test out a board if something is not working as expected. The design files may also be of general interest. The ZIP file has the design source, a script to run them, and the resulting compiled files.
- **Programmer for the STMicroelectronics M29DW323DT Parallel NOR Flash**
www.xilinx.com/products/boards/s3astarter/reference_designs.htm#parallel_flash_programmer
This design transforms the Spartan-3A or Spartan-3AN FPGA into a programmer for the 32Mbit STMicroelectronics M29DW323DT parallel NOR Flash memory. This memory optionally holds configuration images for the FPGA and provides general non-volatile storage for other applications implemented within the FPGA. Using a simple terminal program, this application provides the following capabilities:
 - ◆ Erase the memory in part or in full
 - ◆ Read the memory to verify contents
 - ◆ Download complete configuration images using standard MCS files
 - ◆ Manually program individual bytes
 - ◆ Display the device identifier and 64-bit unique device numbers
- **Spartan-3A/3AN “Device DNA” Reader**
www.xilinx.com/products/boards/s3astarter/reference_designs.htm#dna_reader
This design uses a PicoBlaze™ processor to read the unique “Device DNA” identifier embedded in each Spartan-3A/3AN FPGA and then display it on the LCD screen.

Choose a Spartan-3 Generation Starter Kit Board for your Needs

The Spartan-3A and Spartan-3AN Starter Kit boards are best for prototyping Spartan-3A/3AN FPGA applications. Depending on specific requirements, however, Xilinx and third-party companies offer development boards that better suit other needs.

Spartan-3A/3AN FPGA Features and Embedded Processing Functions

The Spartan-3A/3AN Starter Kit board highlights the unique features of the Spartan-3A and Spartan-3AN FPGA families and provides a convenient development board for embedded processing applications. The board highlights these features:

- Spartan-3AN specific features
 - ◆ Nonvolatile configuration from internal SPI Flash
- Spartan-3A/3AN specific features
 - ◆ Parallel NOR Flash configuration
 - ◆ SPI serial Flash configuration using either the STMicroelectronics or Atmel DataFlash architectures
 - ◆ MultiBoot FPGA configuration from both Parallel NOR and SPI serial Flash PROMs
- Embedded development
 - ◆ [MicroBlaze](#) 32-bit embedded RISC processor

- ◆ [PicoBlaze](#) eight-bit embedded controller
- Power management using the Suspend mode feature
- DDR2 SDRAM memory interfaces

Other Spartan-3 Generation Development Boards

The Spartan-3A/3AN Starter Kit board demonstrates the full capabilities of the Spartan-3A and Spartan-3AN FPGA families and the Xilinx ISE® development software.

For a development board specific to the Spartan-3E FPGA family, consider the Spartan-3E Starter Kit board. There are multiple ordering codes, depending on the included power supply.

- **Spartan-3E Starter Kit Board (HS-SPAR3E-SK_xx)**
www.xilinx.com/s3estarter

For MicroBlaze™ processor development, consider the Spartan-3A DSP Embedded Development board.

- **Spartan-3A DSP S3D1800A MicroBlaze Processor Edition (DO-SD1800A-EDK-DK-UNI-G)**
www.xilinx.com/products/devkits/DO-SD1800A-EDK-DK-UNI-G.htm

For PCI Express® applications, consider the Spartan-3 PCI Express Starter Kit.

- **Spartan-3 PCI Express Starter Kit (HW-S3PCIE-DK)**
www.xilinx.com/s3pcie

For simple Spartan-3 FPGA applications, consider the fairly basic Spartan-3 Starter Kit board.

- **Spartan-3 Starter Kit (DO-SPAR3-DK)**
www.xilinx.com/s3starter

Also consider the capable boards offered by Xilinx partners:

- **Spartan-3 Generation Board Interactive Search**
www.xilinx.com/products/devboards/index.htm

Spartan-3A and Spartan-3AN FPGAs

The Spartan-3AN FPGA platform offers nonvolatile pin-compatible versions of the Spartan-3A FPGA platform. The Spartan-3AN FPGAs support the same external programming sources as Spartan-3A FPGAs, but add an additional internal SPI Flash programming mode. The internal SPI Flash can also be used for user data. The Spartan-3A/3AN Starter Kit Board supports both external and Spartan-3AN internal configuration options.

Spartan-3AN FPGAs require V_{CCAUX} to be 3.3V while Spartan-3A FPGAs allow V_{CCAUX} to be either 2.5V or 3.3V. The Spartan-3A/3AN Starter Kit Board uses a default V_{CCAUX} of 3.3V.

Spartan-3A and Spartan-3AN FPGAs have different documentation and availability. Verify the latest version of the appropriate documentation on xilinx.com.

- Spartan-3A FPGAs
 - ◆ Web page
www.xilinx.com/spartan3a
 - ◆ Data sheet
www.xilinx.com/support/documentation/data_sheets/ds529.pdf
 - ◆ Errata
www.xilinx.com/support/documentation/spartan-3a_errata.htm
 - ◆ Additional documentation
www.xilinx.com/support/documentation/spartan-3a.htm
- Spartan-3AN FPGAs
 - ◆ Web page
www.xilinx.com/spartan3an
 - ◆ Data sheet
www.xilinx.com/support/documentation/data_sheets/ds557.pdf
 - ◆ Errata
www.xilinx.com/support/documentation/spartan-3an_errata.htm
 - ◆ Additional documentation
www.xilinx.com/support/documentation/spartan-3an.htm

Related Resources

Refer to the following links for additional information:

- **Spartan-3A/3AN Starter Kit**
www.xilinx.com/s3astarter
 - ◆ Spartan-3A/3AN Rev D Starter Kit user guide (this document)
 - ◆ Spartan-3A Rev C Starter Kit user guide
www.xilinx.com/support/documentation/boards_and_kits/ug330.pdf
 - ◆ Example User Constraints File (UCF)
www.xilinx.com/products/boards/s3astarter/files/s3astarter.ucf
 - ◆ Board schematics (annotated)
www.xilinx.com/products/boards/s3astarter/s3astarter_schematic.pdf
 - ◆ Bill of materials (BOM) list
www.xilinx.com/products/boards/s3astarter/s3astarter_bom.xls
 - ◆ Link to design examples
www.xilinx.com/products/boards/s3astarter/reference_designs.htm
- **Xilinx MicroBlaze™ Soft Processor**
www.xilinx.com/microblaze
- **Xilinx PicoBlaze™ Soft Processor**
www.xilinx.com/picoblaze
- **Xilinx Embedded Development Kit**
www.xilinx.com/ise/embedded_design_prod/platform_studio.htm
- **Xilinx Software Tutorials**
www.xilinx.com/support/techsup/tutorials/
- **Xilinx Technical Support**
www.xilinx.com/support

Switches, Buttons, and Rotary Knob

Slide Switches

Locations and Labels

The Spartan®-3A/3AN FPGA Starter Kit board has four slide switches, as shown in [Figure 2-1](#). The slide switches are located in the lower right corner of the board and are labeled SW3 through SW0. Switch SW3 is the left-most switch, and SW0 is the right-most switch.

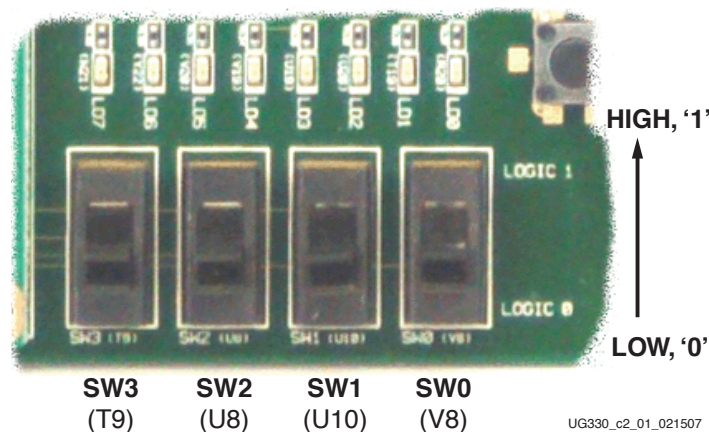

Figure 2-1: Four Slide Switches

Operation

When in the UP or ON position, a switch connects the FPGA pin to 3.3V, a logic High. When DOWN or in the OFF position, the switch connects the FPGA pin to ground, a logic Low. The switches typically exhibit about 2 ms of mechanical bounce. There is no active debouncing circuitry, although such circuitry could easily be added to the FPGA design programmed on the board.

UCF Location Constraints

[Figure 2-2](#) provides the UCF constraints for the four slide switches, including the I/O pin assignment and the I/O standard used. The PULLUP resistor is not required, but it defines the input value when the switch is in the middle of a transition.

```

NET "SW<0>" LOC = "V8" | IOSTANDARD = LVCMOS33 ;
NET "SW<1>" LOC = "U10" | IOSTANDARD = LVCMOS33 ;
NET "SW<2>" LOC = "U8" | IOSTANDARD = LVCMOS33 ;
NET "SW<3>" LOC = "T9" | IOSTANDARD = LVCMOS33 ;

```

Figure 2-2: UCF Constraints for Slide Switches

SUSPEND Switch

The SUSPEND slide switch, shown in Figure 2-3, connects directly to the FPGA's SUSPEND input pin. If Suspend mode is enabled in the FPGA application, then the FPGA enters Suspend mode whenever the switch is set to "SUSPEND." If the switch is then changed back to "RUN," then the FPGA resumes operation from the state before it entered Suspend mode. Likewise, if Suspend mode is enabled, then the AWAKE pin is reserved to indicate when the FPGA is in Suspend mode. See "AWAKE LED," page 32.

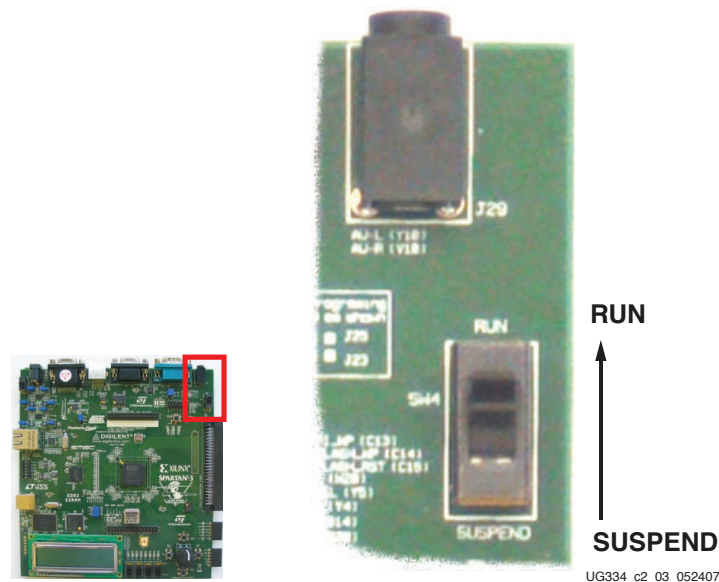

Push-Button Switches

Locations and Labels

The Spartan-3A/3AN Starter Kit board has four momentary-contact push-button switches, shown in Figure 2-5. The push buttons are located in the lower right corner of the board and are labeled BTN_NORTH, BTN_EAST, BTN_SOUTH, and BTN_WEST. The FPGA pins that connect to the push buttons appear in parentheses in Figure 2-5, and the associated UCF is listed in Figure 2-7.

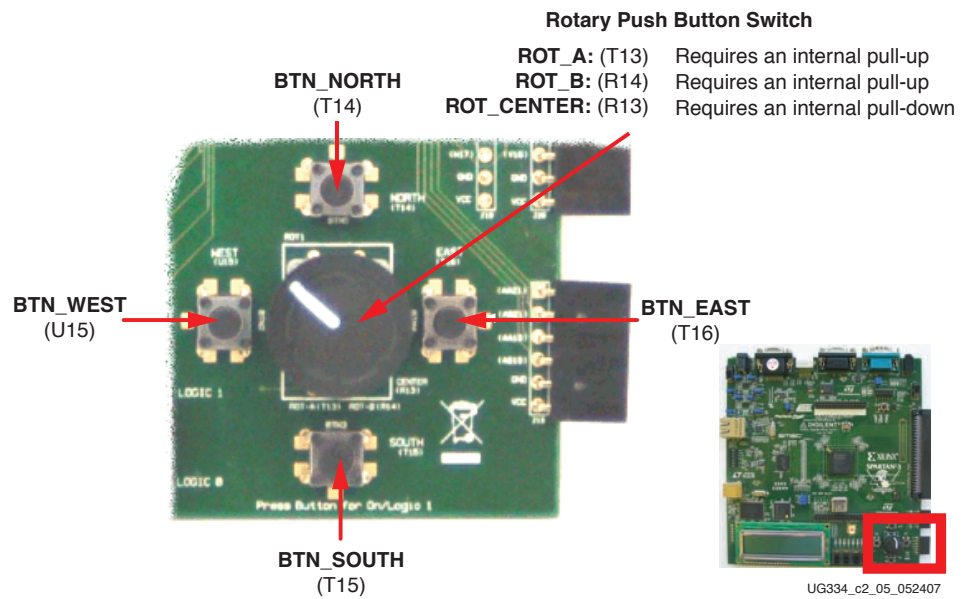

Notes:

- 1. All BTN_* push-button inputs require an internal pull-down resistor.

Figure 2-5: Four Push-Button Switches Surround the Rotary Push-Button Switch

Operation

Pressing a push button connects the associated FPGA pin to 3.3V, as shown in Figure 2-6. Use an internal pull-down resistor within the FPGA pin to generate a logic Low when the button is not pressed. Figure 2-7 shows how to specify a pull-down resistor within the UCF. There is no active debouncing circuitry on the push button.

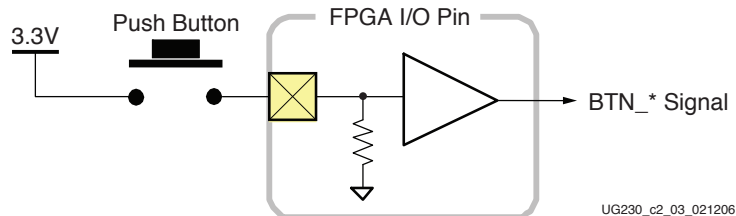

Figure 2-6: Push-Button Switches Require an Internal Pull-Down Resistor in the FPGA Input Pin

PROG_B Push-Button Switch

The PROG_B push-button switch, shown in [Figure 2-14, page 31](#), is part of the FPGA's configuration circuitry. See "PROG Push-Button Switch," [page 40](#).

UCF Location Constraints

[Figure 2-7](#) provides the UCF constraints for the four push-button switches, including the I/O pin assignment and the I/O standard used, and defines a pull-down resistor on each input.

```
NET "BTN_EAST" LOC = "T16" | IOSTANDARD = LVCMOS33 | PULLDOWN ;
NET "BTN_NORTH" LOC = "T14" | IOSTANDARD = LVCMOS33 | PULLDOWN ;
NET "BTN_SOUTH" LOC = "T15" | IOSTANDARD = LVCMOS33 | PULLDOWN ;
NET "BTN_WEST" LOC = "U15" | IOSTANDARD = LVCMOS33 | PULLDOWN ;
```

Figure 2-7: UCF Constraints for Push-Button Switches

Rotary Push-Button Switch

Locations and Labels

The rotary push-button switch is located in the center of the four individual push-button switches, as shown in [Figure 2-5, page 27](#). The switch produces three outputs. The two shaft encoder outputs are ROT_A and ROT_B. The center push-button switch is ROT_CENTER.

Operation

The rotary push-button switch integrates two different functions. The switch shaft rotates and outputs values whenever the shaft turns. The shaft can also be pressed, acting as a push-button switch.

Push-Button Switch

Pressing the knob on the rotary/push-button switch connects the associated FPGA pin to 3.3V, as shown in [Figure 2-8](#). Use an internal pull-down resistor within the FPGA pin to generate a logic Low. [Figure 2-11](#) shows how to specify a pull-down resistor within the UCF. There is no active debouncing circuitry on the push button.

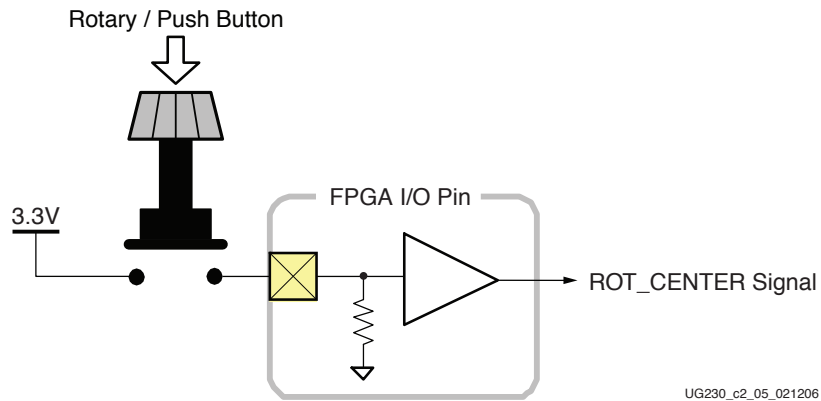

Figure 2-8: Push-Button Switches Require an Internal Pull-up Resistor in the FPGA Input Pin

Rotary Shaft Encoder

In principal, the rotary shaft encoder behaves much like a cam connected to the central shaft. Rotating the shaft then operates two push-button switches, as shown in Figure 2-9. Depending on which way the shaft is rotated, one of the switches opens before the other. Likewise, as the rotation continues, one switch closes before the other. However, when the shaft is stationary, also called the *detent* position, both switches are closed.

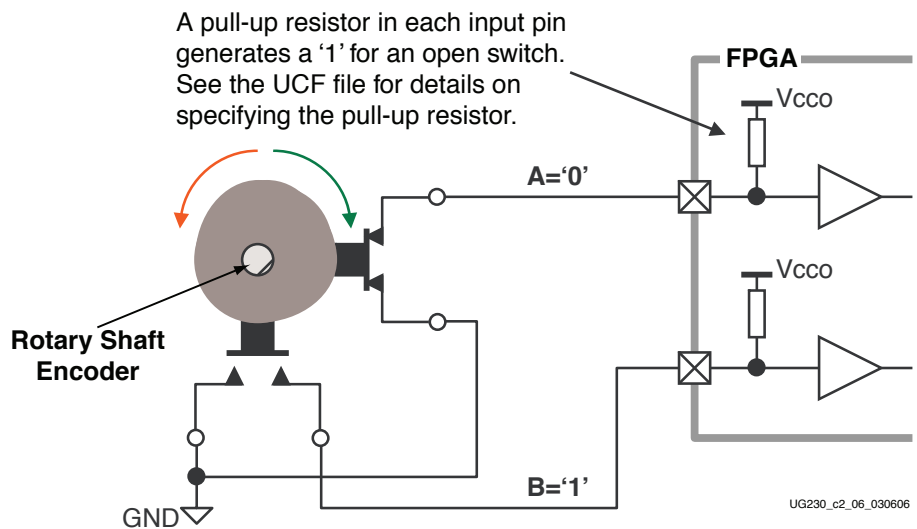

Figure 2-9: Basic Example of Rotary Shaft Encoder Circuitry

Closing a switch connects it to ground, generating a logic Low. When the switch is open, a pull-up resistor within the FPGA pin pulls the signal to a logic High. The UCF constraints in Figure 2-11 describe how to define the pull-up resistor.

The FPGA circuitry to decode the 'A' and 'B' inputs is simple but must consider the mechanical switching noise on the inputs, also called chatter. As shown in Figure 2-10, the chatter can falsely indicate extra rotation events or even indicate rotations in the opposite direction!

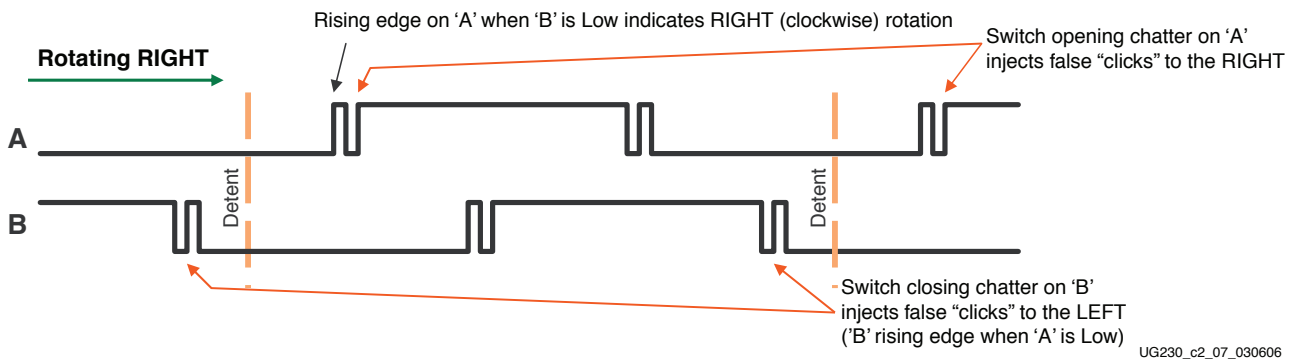

Figure 2-10: Outputs from Rotary Shaft Encoder Might Include Mechanical Chatter

UCF Location Constraints

Figure 2-11 provides the UCF constraints for the rotary encoder/push-button switch, including the I/O pin assignment and the I/O standard used, and defines a pull-up or pull-down resistor for each FPGA input.

```
NET "ROT_A"      LOC = "T13" | IOSTANDARD = LVCMOS33 | PULLUP ;
NET "ROT_B"      LOC = "R14" | IOSTANDARD = LVCMOS33 | PULLUP ;
NET "ROT_CENTER" LOC = "R13" | IOSTANDARD = LVCMOS33 | PULLDOWN ;
```

Figure 2-11: UCF Constraints for Rotary Push-Button Switch

Discrete LEDs

Locations and Labels

The Spartan-3A/3AN Starter Kit board has eight individual surface-mount LEDs located immediately above the slide switches as shown in Figure 2-12. The LEDs are labeled LED7 through LED0. LED7 is the left-most LED, LED0 the right-most LED.

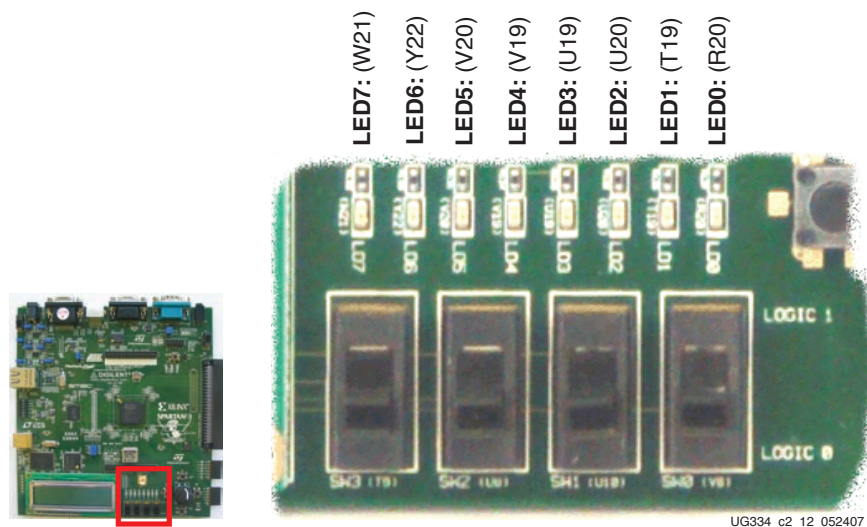

Figure 2-12: Eight Discrete LEDs

Operation

Each LED has one side connected to ground and the other side connected to a pin on the device via a 390Ω current limiting resistor. To light an individual LED, drive the associated FPGA control signal High.

If the FPGA is not yet configured, the LEDs may be dimly lit because pull-up resistors are enabled during configuration. The FPGA's PUDC_B pin is connected to GND on the board.

UCF Location Constraints

Figure 2-13 provides the UCF constraints for the four push-button switches, including the I/O pin assignment, the I/O standard used, the output slew rate, and the output drive current.

```

NET "LED<7>" LOC = "W21" | IOSTANDARD = LVCMOS33 | SLEW = SLOW | DRIVE = 8 ;
NET "LED<6>" LOC = "Y22" | IOSTANDARD = LVCMOS33 | SLEW = SLOW | DRIVE = 8 ;
NET "LED<5>" LOC = "V20" | IOSTANDARD = LVCMOS33 | SLEW = SLOW | DRIVE = 8 ;
NET "LED<4>" LOC = "V19" | IOSTANDARD = LVCMOS33 | SLEW = SLOW | DRIVE = 8 ;
NET "LED<3>" LOC = "U19" | IOSTANDARD = LVCMOS33 | SLEW = SLOW | DRIVE = 8 ;
NET "LED<2>" LOC = "U20" | IOSTANDARD = LVCMOS33 | SLEW = SLOW | DRIVE = 8 ;
NET "LED<1>" LOC = "T19" | IOSTANDARD = LVCMOS33 | SLEW = SLOW | DRIVE = 8 ;
NET "LED<0>" LOC = "R20" | IOSTANDARD = LVCMOS33 | SLEW = SLOW | DRIVE = 8 ;
    
```

Figure 2-13: UCF Constraints for Eight Discrete LEDs

Optional Discrete LEDs

The Spartan-3A/3AN Starter Kit board provides two optional LEDs, shown in Figure 2-14. Depending on which features are used by an application, these LED connections may be also used as user-I/O pins.

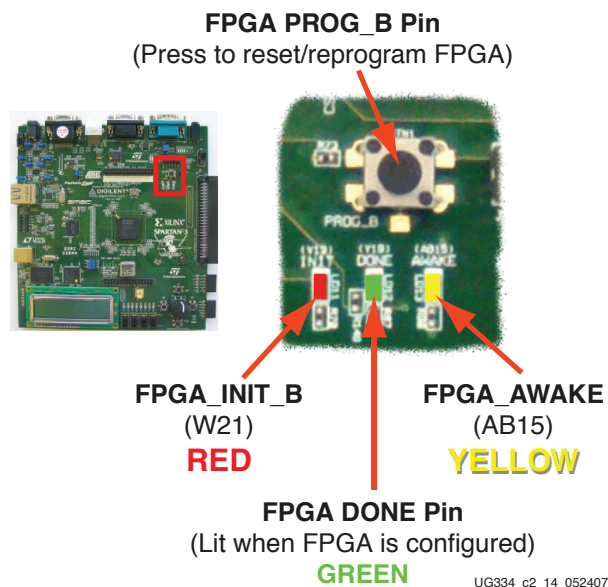

Figure 2-14: AWAKE and INIT_B LEDs

AWAKE LED

The yellow-colored AWAKE LED connects to the FPGA's AWAKE pin and is used if the FPGA Suspend mode is enabled in the bitstream. If the Suspend mode is not used, then the FPGA's AWAKE pin is available as a full user-I/O pin.

If the FPGA is not yet configured, the FPGA's AWAKE pin is dimly lit because pull-up resistors are enabled during configuration. The FPGA's PUDC_B pin is connected to GND on the board.

To light the AWAKE LED in an application, drive the AWAKE pin High.

INIT_B LED

The red-colored INIT_B LED serves multiple purposes:

- At power-up or when the PROG_B button is pressed, the LED flashes momentarily while the FPGA clears its configuration memory.
- If configuration fails for any reason, then the FPGA's DONE LED will be unlit and the INIT_B LED will light. This indicates that the FPGA could not successfully configure.
- After the FPGA successfully completes, the INIT_B pin is available as a general-purpose user-I/O pin. If no signal drives INIT_B, then it is defined as an input pin with a pull-down resistor. It might appear that the LED dimly glows. Drive the INIT_B pin High to turn off the LED or Low to light the LED.
- If using the Readback CRC feature, the INIT_B pin is reserved and signals a CRC error after configuration. If such an error occurs, the FPGA drives INIT_B Low, lighting the LED.

If using the INIT_B pin as a user-I/O pin after configuration, drive the pin Low to light the LED and High to shut it off. Jumper J46, shown in [Table 4-2, page 40](#), must be in either the "Disabled" or "Enabled during Configuration" setting.

The "Always Enabled" setting for Jumper J46 allows the FPGA to read additional data from the Platform Flash PROM after configuration, as described in Xilinx application note [XAPP694](#).

Caution! The FPGA's INIT_B pin also connects to the Platform Flash PROM's \overline{OE} /RESET pin. If the jumper controlling the Platform Flash PROM, jumper J46 in [Table 4-2, page 40](#), is set to "Always Enabled," then the INIT_B signal controls the PROM's active-Low output-enable (\overline{OE}) input or active-High RESET input.

- **XAPP694: Reading User Data from Configuration PROMs**
www.xilinx.com/support/documentation/application_notes/xapp694.pdf

UCF Location Constraints

[Figure 2-15](#) provides the UCF constraints for the optional LEDs, including the I/O pin assignment, the I/O standard used, the output slew rate, and the output drive current. The ENABLE_SUSPEND constraint must be set to NO in order to use FPGA_AWAKE LED.

```
NET "FPGA_INIT_B" LOC = "V13" | IOSTANDARD = LVCMOS33 | SLEW = SLOW | DRIVE = 8 ;

# The AWAKE LED is only available if Suspend mode is disabled
CONFIG ENABLE_SUSPEND = NO ;
NET "FPGA_AWAKE" LOC = "AB15" | IOSTANDARD = LVCMOS33 | SLEW = SLOW | DRIVE = 8 ;
```

Figure 2-15: UCF Constraints for Optional Discrete LEDs

Clock Sources

Overview

The Spartan[®]-3A/3AN FPGA Starter Kit board supports three primary clock input sources, as shown in [Figure 3-1](#).

- The board includes an on-board 50 MHz clock oscillator.
- Clocks can be supplied off-board via an SMA-style connector. Alternatively, the FPGA can generate clock signals or other high-speed signals on the SMA-style connector.
- A 133 MHz clock oscillator is installed in the CLK_AUX socket. Optionally substitute a separate eight-pin DIP-style clock oscillator in the provided socket.

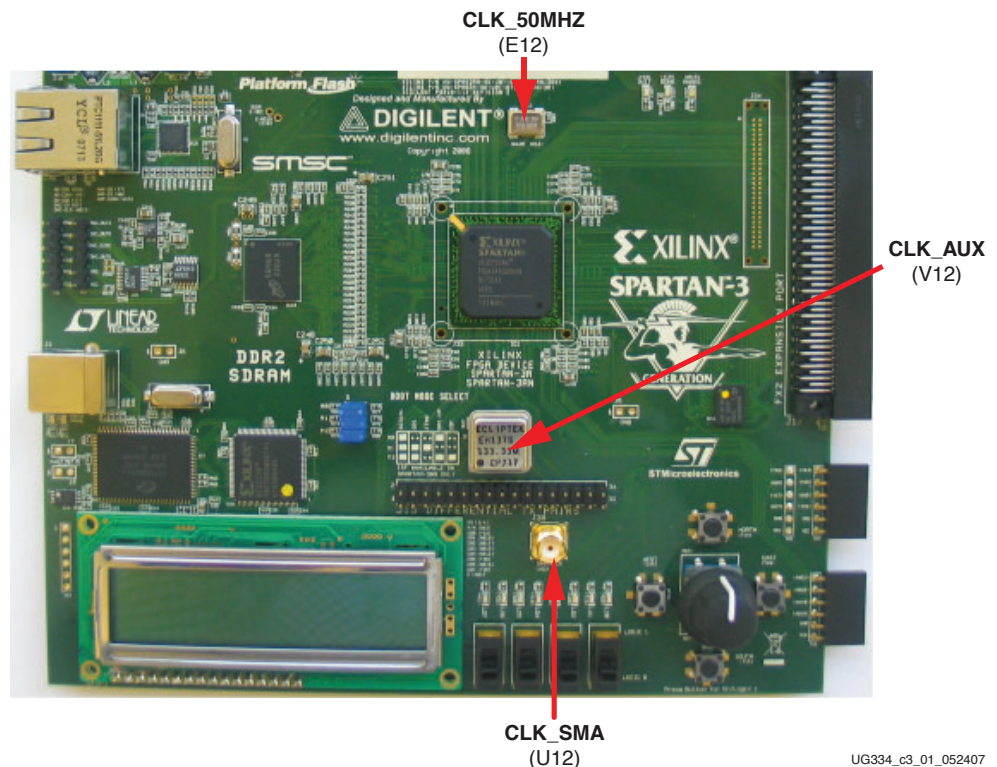

Figure 3-1: Clock Sources on Starter Kit Board

UG334_c3_01_052407

Clock Connections

Each of the clock inputs connect directly to a global buffer input. As shown in [Table 3-1](#), each of the clock inputs also optimally connects to an associated DCM.

Only the CLK_AUX or the CLK_SMA input can use the associated DCM at any time. However, both inputs are available as clock inputs.

Table 3-1: Clock Inputs and Associated Global Buffers and DCMs

Clock Input	FPGA Pin	I/O Bank	Global Buffer	Associated DCM	LOC
CLK_50MHZ	E12	0	GCLK5	Top Right	DCM_X2Y3
CLK_AUX	V12	2	GCLK2	Bottom Right	DCM_X2Y0
CLK_SMA	U12	2	GCLK3		

50 MHz On-Board Oscillator

The board includes a 50 MHz oscillator with a 40% to 60% output duty cycle. The oscillator is accurate to ± 2500 Hz or ± 50 ppm.

Auxiliary Clock Oscillator Socket

A 133 MHz clock oscillator is installed in the auxiliary clock oscillator socket. The provided eight-pin socket accepts clock oscillators that fit the eight-pin DIP (8DIP) footprint. Substitute the oscillator in this socket if the FPGA application requires a frequency other than 50 MHz or 133 MHz. Alternatively, use the FPGA's Digital Clock Manager (DCM) to generate or synthesize other frequencies from the on-board 50 MHz or 133 MHz oscillator.

Caution! Be aware of the pin 1 orientation on the crystal oscillator when installing it in the associated socket.

SMA Clock Input or Output Connector

To provide a clock from an external source, connect the input clock signal to the SMA connector. The FPGA can also generate a single-ended clock output or other high-speed signal on the SMA clock connector for an external device.

UCF Constraints

The clock input sources require two different types of constraints. The *location* constraints define the I/O pin assignments and I/O standards. The *period* constraints define the clock period—and consequently the clock frequency—and the duty cycle of the incoming clock signal.

Location

[Figure 3-2](#) provides the UCF constraints for the three clock input sources, including the I/O pin assignment and the I/O standard used.

```
NET "CLK_50MHZ" LOC = "E12" | IOSTANDARD = LVCMOS33 ;  
NET "CLK_AUX" LOC = "V12" | IOSTANDARD = LVCMOS33 ;  
NET "CLK_SMA" LOC = "U12" | IOSTANDARD = LVCMOS33 ;
```

Figure 3-2: UCF Location Constraints for Clock Sources

Clock Period Constraints

The Xilinx ISE® development software uses timing-driven logic placement and routing. Set the clock PERIOD constraint as appropriate. An example constraint appears in Figure 3-3 for the on-board 50 MHz clock oscillator. The CLK_50MHZ frequency is 50 MHz, which equates to a 20 ns period. The output duty cycle from the oscillator ranges between 40% to 60%.

```
# Define clock period for 50 MHz oscillator  
NET "CLK_50MHZ" PERIOD = 20.0ns HIGH 40%;
```

Figure 3-3: UCF Clock PERIOD Constraint

Related Resources

Refer to the following links for additional information:

- **Epson SG-8002JF Series Oscillator Data Sheet (50 MHz Oscillator)**
<http://www.eea.epson.com/portal/pls/portal/docs/1/793426.PDF>

FPGA Configuration Options

The Spartan®-3A/3AN FPGA Starter Kit board supports a variety of FPGA configuration options:

- Program the Spartan-3AN internal SPI Flash memory, then configure the FPGA at power-up. This option is not available in the Spartan-3A Starter Kit.
- Download FPGA designs directly to the Spartan-3A/3AN FPGA via JTAG, using the on-board USB interface. The on-board USB-JTAG logic also provides in-system programming for the on-board Platform Flash PROM. SPI serial Flash and StrataFlash programming are performed separately.
- Program the on-board 4 Mbit Xilinx XCF04S serial [Platform Flash PROM](#), then configure the FPGA from the image stored in the Platform Flash PROM using Master Serial mode.
- Program the on-board 16 Mbit STMicroelectronics SPI serial Flash PROM or the 16 Mbit Atmel SPI-based DataFlash PROM, then configure the FPGA from the image stored in the SPI serial Flash PROM using SPI mode. Further, an FPGA application can dynamically load different FPGA configurations using the FPGA's MultiBoot mode. See [UG332: Spartan-3 Generation Configuration User Guide](#) for additional details on the MultiBoot feature. See [Chapter 12, "SPI Serial Flash,"](#) for more information on using SPI serial Flash memory.
- Program the on-board 32 Mbit STMicroelectronics parallel NOR Flash PROM, then configure the FPGA from the image stored in the Flash PROM using BPI Up configuration mode. Further, an FPGA application can dynamically load different FPGA configurations using the FPGA's MultiBoot mode. See [UG332: Spartan-3 Generation Configuration User Guide](#) for additional details on the MultiBoot feature. See [Chapter 11, "Parallel NOR Flash PROM,"](#) for more information on using parallel Flash memory.

Figure 4-1 indicates the position of the USB download/programming interface and the on-board non-volatile memories that potentially store FPGA configuration images.

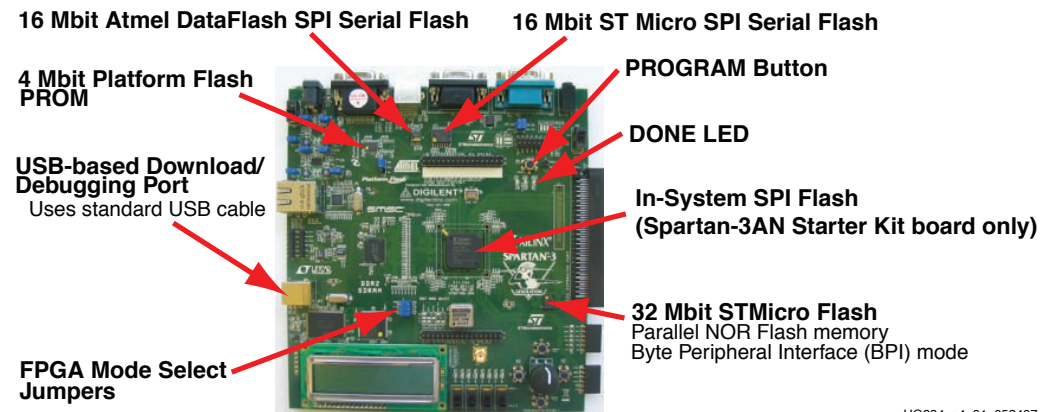

Figure 4-1: Starter Kit FPGA Configuration Options

The configuration mode jumpers determine which configuration mode the FPGA uses when power is first applied, or whenever the PROG button is pressed.

The DONE pin LED lights when the FPGA successfully finishes configuration.



Pressing the PROG button forces the FPGA to restart its configuration process.

The Xilinx Platform Flash PROM provides easy, JTAG-programmable configuration storage for the FPGA. The FPGA configures from the Platform Flash using Master Serial mode.

Configuration Mode Jumpers

As shown in [Table 4-1](#), the J26 jumper block settings control the FPGA's configuration mode. Inserting a jumper grounds the associated mode pin. Insert or remove individual jumpers to select the FPGA's configuration mode and associated configuration memory source. The J26 jumper block is shown in [Figure 4-1](#).

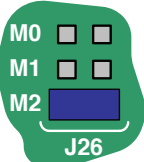
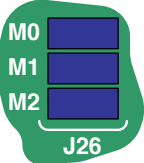
Table 4-1: Configuration Mode Jumper Settings

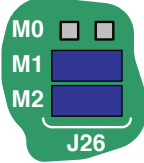
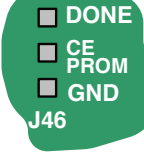
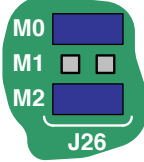
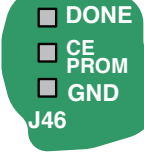
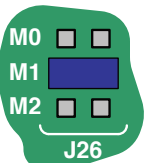
Configuration Mode	Mode Pins M2:M1:M0	FPGA Configuration Image Source	J26 Jumper Settings	J46 Jumper Setting
Internal Master SPI	0:1:1	<i>Spartan-3AN Starter Kit Board only!</i> This mode configures a Spartan-3AN FPGA using the internal In-System Flash memory. This mode is not supported on the Spartan-3A Starter Kit board.		
Master Serial	0:0:0	Platform Flash PROM Set the J46 jumper per Table 4-2		
Master SPI (see Chapter 12 , "SPI Serial Flash")	0:0:1	Select SPI Serial Flash PROM starting at address 0 Select specific SPI Flash PROM using Jumper J1 (Table 12-2 , page 93). Disable the Platform Flash PROM via J46 jumper per Table 4-2 .		DISABLE 
Master BPI Up (see Chapter 11 , "Parallel NOR Flash PROM")	0:1:0	Parallel NOR Flash PROM, starting at address 0 and incrementing through address space. Disable the Platform Flash PROM via J46 jumper per Table 4-2 .		
JTAG	1:0:1	Downloaded from host via USB-JTAG port		

Xilinx Platform Flash Configuration PROM(s)

The Spartan-3A/3AN Starter Kit board includes a Xilinx Platform Flash configuration interface. A single 4 Mbit XCF04S Platform Flash PROM appears in the JTAG chain with the FPGA.

Caution! The J46 jumper, shown in [Table 4-2, page 40](#), enables or disables the Platform Flash PROM on the board. Be aware of potential data contention issues with the SPI serial Flash and the D0 line of the parallel NOR Flash, depending on the current FPGA “[Configuration Mode Jumpers](#)”, shown in [Table 4-1](#).

Caution! If the J46 jumper shown in [Table 4-2, page 40](#) is set for “Always Enabled”, then the FPGA’s INIT_B pin controls the Platform Flash PROM’s \overline{OE} /RESET input. The INIT_B pin must be High to read any data, other than from the Platform Flash PROM.

When using the Platform Flash PROM to configure the FPGA, the configuration mode jumpers *must* be set for Master Serial mode, as shown in [Table 4-2](#). If using any other configuration mode, the Platform Flash PROM *must* be disabled.

Table 4-2: Platform Flash Enable Jumper (J46)

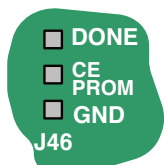
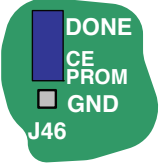
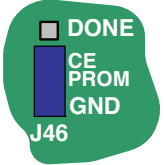
Platform Flash Mode	Platform Flash Enable (J46)	Allowed FPGA Configuration Mode	Precautions/Contention
Disabled (no jumper)		Any (see Table 4-1)	None. Platform Flash disabled. The FPGA application has full access to SPI serial Flash and parallel NOR Flash PROMs after configuration.
Enabled during FPGA Configuration		Master Serial or JTAG	None. Platform Flash enabled during configuration and disabled after configuration. The FPGA application has full access to SPI serial Flash and parallel NOR Flash PROMs after configuration.
Always Enabled		Master Serial or JTAG	Platform Flash continuously enabled. The FPGA application can read additional data from Platform Flash after configuration as described in application note XAPP694: Reading User Data from Configuration PROMs . The FPGA application has no read access to SPI Flash or parallel NOR Flash.

PROG Push-Button Switch

The PROG push-button switch, labeled in [Figure 4-1](#), forces the FPGA to reconfigure from the configuration memory source selected by the “[Configuration Mode Jumpers](#),” [page 39](#). Press and release this button to restart the FPGA configuration process at any time.

DONE Pin LED

The DONE pin LED, labeled in [Figure 4-1](#), lights whenever the FPGA is successfully configured. If this LED is not lit, then the FPGA is not configured.

Programming the FPGA or Platform Flash PROM via USB

The Spartan-3A/3AN Starter Kit includes embedded USB-based programming logic and a USB endpoint with a Type B connector. Via a USB cable connection with the host PC, the iMPACT programming software directly programs the FPGA, the Platform Flash PROM, or the on-board CPLD. Direct programming of the parallel or serial Flash PROMs is not presently supported.

Connecting the USB Cable

The kit includes a standard USB Type A/Type B cable, similar to the one shown in [Figure 4-2](#). The actual cable color might vary from the picture.

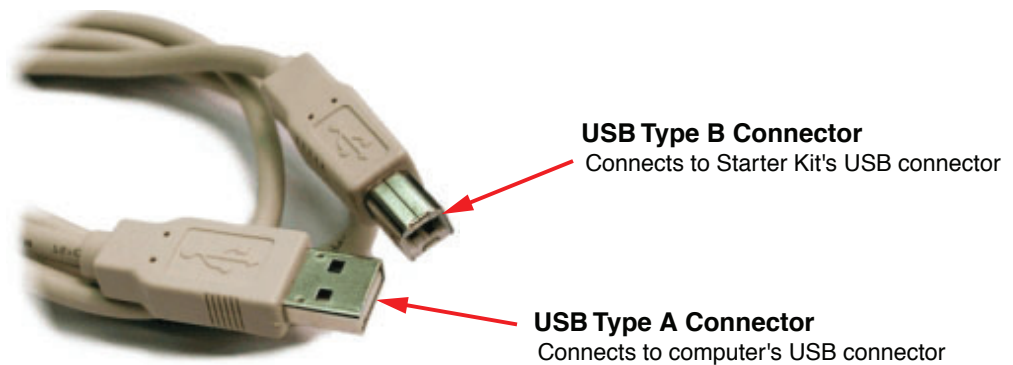

UG230_c4_04_030306

Figure 4-2: Standard USB Type A/Type B Cable

The wider and narrower Type A connector fits the USB connector at the back of the computer.

After installing the Xilinx software, connect the square Type B connector to the Spartan-3A/3AN Starter Kit board, as shown in [Figure 4-3](#). The USB connector is on the left side of the board, immediately next to the Ethernet connector. When the board is powered on, the Windows operating system automatically recognizes and installs the associated driver software.

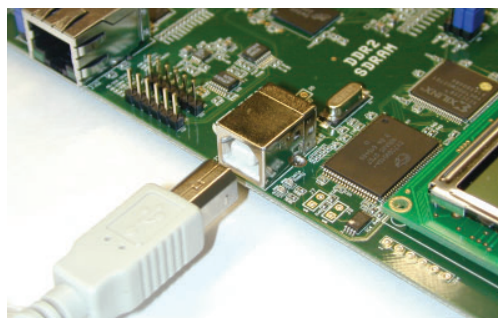

UG334_c4_03_052407

Figure 4-3: Connect the USB Type B Connector to the Starter Kit Board Connector

When the USB cable driver is successfully installed and the board is correctly connected to the PC, a green LED lights up, indicating that the programming cable is ready. The USB connection also has a red LED, which only lights if the Xilinx software is programming firmware updates to the USB interface.

Platform Flash Programming Example in Spartan-3 Generation Configuration User Guide

The *Spartan-3 Generation Configuration User Guide* includes step-by-step instructions, some including screen shots, on how to prepare the FPGA bitstream and download it to the FPGA or PROM.

- **UG332: Spartan-3 Generation Configuration User Guide**
www.xilinx.com/support/documentation/user_guides/ug332.pdf

For formatting and programming Platform Flash PROMs, please refer to the “*Master Serial Mode*” chapter.

Character LCD Screen

Overview

The Spartan-3A/3AN Starter Kit board prominently features a 2-line by 16-character liquid crystal display (LCD). The FPGA controls the LCD via the eight-bit data interface shown in Figure 5-1. The Spartan-3A/3AN Starter Kit board also supports the four-bit data interface to remain compatible with other Xilinx development boards.

Caution! When using four-bit mode, the FPGA must drive the LCD_DB<3:0> signals High.

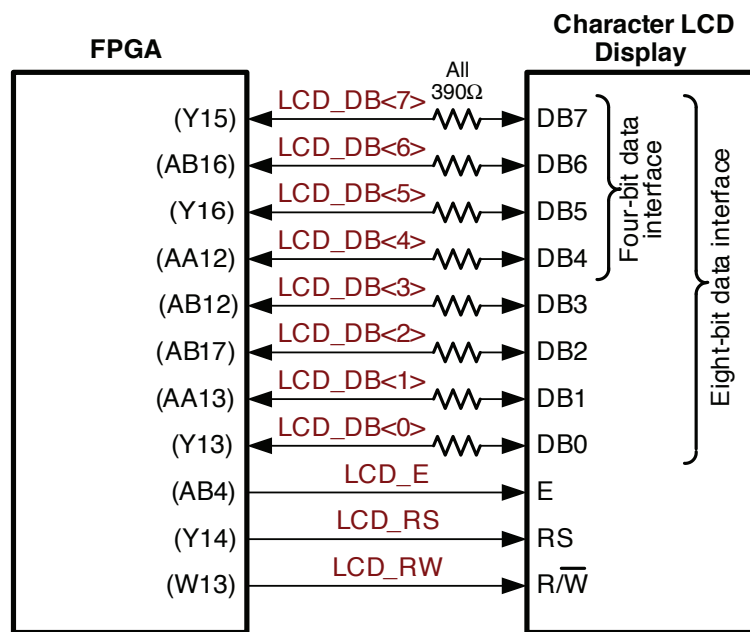

UG334_c5_01_052407

Figure 5-1: Character LCD Interface

Once mastered, the LCD is a practical way to display a variety of information using standard ASCII and custom characters. However, these displays are not fast. Scrolling the display at half-second intervals tests the practical limit for clarity. Compared with the 50 MHz clock available on the board, the display is slow. A PicoBlaze processor efficiently controls display timing plus the actual content of the display.

Character LCD Interface Signals

Table 5-1 shows the interface character LCD interface signals.

Table 5-1: Character LCD Interface

Signal Name	FPGA Pin	Function	
LCD_DB<7>	Y15	Data bit DB7	
LCD_DB<6>	AB16	Data bit DB6	
LCD_DB<5>	Y16	Data bit DB5	
LCD_DB<4>	AA12	Data bit DB4	
LCD_DB<3>	AB12	Data bit DB3	When using the four-bit interface, drive these signals High.
LCD_DB<2>	AB17	Data bit DB2	
LCD_DB<1>	AB18	Data bit DB1	
LCD_DB<0>	Y13	Data bit DB0	
LCD_E	AB4	Read/Write Enable Pulse 0: Disabled 1: Read/Write operation enabled	
LCD_RS	Y14	Register Select 0: Instruction register during write operations. Busy Flash during read operations 1: Data for read or write operations	
LCD_RW	W13	Read/Write Control 0: Write, LCD accepts data 1: Read, LCD presents data	

Voltage Compatibility

The character LCD is power by +5V. The FPGA I/O signals are powered by 3.3V. However, the FPGA's output levels are recognized as valid Low or High logic levels by the LCD. The LCD controller accepts 5V TTL signal levels and the 3.3V LVCMOS outputs provided by the FPGA meet the 5V TTL voltage level requirements.

The 390Ω series resistors on the data lines prevent overstressing on the FPGA and StrataFlash I/O pins when the character LCD drives a High logic value. The character LCD drives the data lines when LCD_RW is High. Most applications treat the LCD as a write-only peripheral and never read from the display.

UCF Location Constraints

Figure 5-2 provides the UCF constraints for the Character LCD, including the I/O pin assignment and the I/O standard used.

```

NET "LCD_E" LOC = "AB4" | IOSTANDARD = LVCMOS33 | DRIVE = 8 | SLEW = SLOW ;
NET "LCD_RS" LOC = "Y14" | IOSTANDARD = LVCMOS33 | DRIVE = 8 | SLEW = SLOW ;
NET "LCD_RW" LOC = "W13" | IOSTANDARD = LVCMOS33 | DRIVE = 8 | SLEW = SLOW ;

NET "LCD_DB<7>" LOC = "Y15" | IOSTANDARD = LVCMOS33 | DRIVE = 8 | SLEW = SLOW ;
NET "LCD_DB<6>" LOC = "AB16" | IOSTANDARD = LVCMOS33 | DRIVE = 8 | SLEW = SLOW ;
NET "LCD_DB<5>" LOC = "Y16" | IOSTANDARD = LVCMOS33 | DRIVE = 8 | SLEW = SLOW ;
NET "LCD_DB<4>" LOC = "AA12" | IOSTANDARD = LVCMOS33 | DRIVE = 8 | SLEW = SLOW ;
NET "LCD_DB<3>" LOC = "AB12" | IOSTANDARD = LVCMOS33 | DRIVE = 8 | SLEW = SLOW ;
NET "LCD_DB<2>" LOC = "AB17" | IOSTANDARD = LVCMOS33 | DRIVE = 8 | SLEW = SLOW ;
NET "LCD_DB<1>" LOC = "AB18" | IOSTANDARD = LVCMOS33 | DRIVE = 8 | SLEW = SLOW ;
NET "LCD_DB<0>" LOC = "Y13" | IOSTANDARD = LVCMOS33 | DRIVE = 8 | SLEW = SLOW ;
    
```

Figure 5-2: UCF Location Constraints for the Character LCD

LCD Controller

The 2 x 16 character LCD has an internal Sitronix [ST7066U](#) graphics controller that is functionally equivalent with the following devices.

- Samsung [S6A0069X](#) or KS0066U
- Hitachi HD44780
- SMOS SED1278

Memory Map

The controller has three internal memory regions, each with a specific purpose: DD RAM, CG ROM, and CG RAM. The display must be initialized before accessing any of these memory regions.

DD RAM

The Display Data RAM (DD RAM) stores the character code to be displayed on the screen. Most applications interact primarily with DD RAM. The character code stored in a DD RAM location references a specific character bitmap stored either in the predefined [CG ROM](#) character set or in the user-defined [CG RAM](#) character set.

[Figure 5-3](#) shows the default address for the 32 character locations on the display. The upper line of characters is stored between addresses 0x00 and 0x0F. The second line of characters is stored between addresses 0x40 and 0x4F.

		Character Display Addresses																Undisplayed Addresses		
1		00	01	02	03	04	05	06	07	08	09	0A	0B	0C	0D	0E	0F	10	...	27
2		40	41	42	43	44	45	46	47	48	49	4A	4B	4C	4D	4E	4F	50	...	67
		1	2	3	4	5	6	7	8	9	10	11	12	13	14	15	16	17	...	40

Figure 5-3: DD RAM Hexadecimal Addresses (No Display Shifting)

Physically, there are 80 total character locations in DD RAM with 40 characters available per line. Locations 0x10 through 0x27 and 0x50 through 0x67 can be used to store other non-display data. Alternatively, these locations can also store characters that can only be displayed using controller’s display shifting functions.

The [Set DD RAM Address](#) command initializes the address counter before reading or writing to DD RAM. Write DD RAM data using the [Write Data to CG RAM or DD RAM](#) command, and read DD RAM using the [Read Data from CG RAM or DD RAM](#) command.

The DD RAM address counter either remains constant after read or write operations, or auto-increments or auto-decrements by one location, as defined by the I/D set by the [Entry Mode Set](#) command.

CG ROM

The Character Generator ROM (CG ROM) contains the font bitmap for each of the predefined characters that the LCD screen can display, shown in [Figure 5-4](#). The character code stored in [DD RAM](#) for each character location subsequently references a position with the CG ROM. For example, a hexadecimal character code of 0x53 stored in a [DD RAM](#) location displays the character 'S'. The upper nibble of 0x53 equates to $DB[7:4] = 0101$ binary and the lower nibble equates to $DB[3:0] = 0011$ binary. As shown in [Figure 5-4](#), the character 'S' appears on the screen.

English/Roman characters are stored in CG ROM at their equivalent ASCII code addresses.

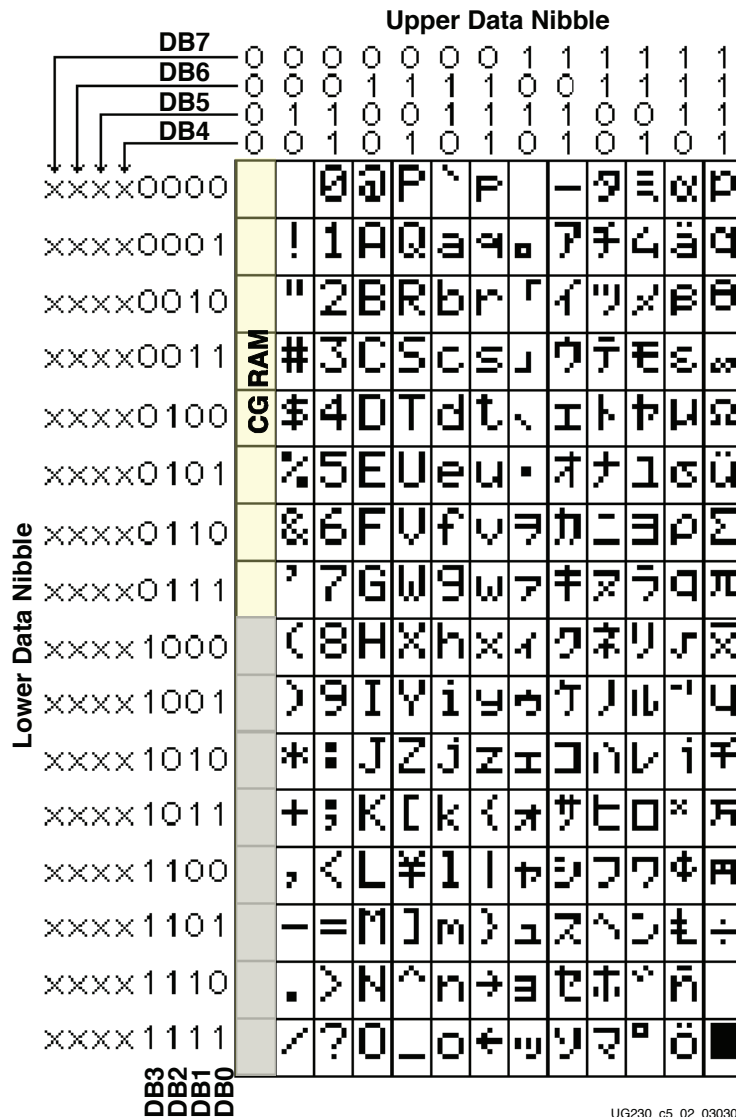

Figure 5-4: LCD Character Set

The character ROM contains the ASCII English character set and Japanese katakana characters.

The controller also provides for eight custom character bitmaps, stored in **CG RAM**. These eight custom characters are displayed by storing character codes 0x00 through 0x07 in a **DD RAM** location.

CG RAM

The Character Generator RAM (CG RAM) provides space to create eight custom character bitmaps. Each custom character location consists of a 5-dot by 8-line bitmap, as shown in [Figure 5-5](#).

The [Set CG RAM Address](#) command initializes the address counter before reading or writing to CG RAM. Write CG RAM data using the [Write Data to CG RAM or DD RAM](#) command, and read CG RAM using the [Read Data from CG RAM or DD RAM](#) command.

The CG RAM address counter either remains constant after read or write operations, or auto-increments or auto-decrements by one location, as defined by the I/D set by the [Entry Mode Set](#) command.

[Figure 5-5](#) provides an example that creates a special *checkerboard* character. The custom character is stored in the fourth CG RAM character location, which is displayed when a DD RAM location is 0x03. To write the custom character, the CG RAM address is first initialized using the [Set CG RAM Address](#) command. The upper three address bits point to the custom character location. The lower three address bits point to the row address for the character bitmap. The [Write Data to CG RAM or DD RAM](#) command is used to write each character bitmap row. A '1' lights a bit on the display. A '0' leaves the bit unlit. Only the lower five data bits are used; the upper three data bits are *don't care* positions. The eighth row of bitmap data is usually left as all zeros to accommodate the cursor.

						Upper Nibble				Lower Nibble			
						Write Data to CG RAM or DD RAM							
A5	A4	A3	A2	A1	A0	D7	D6	D5	D4	D3	D2	D1	D0
Character Address			Row Address			Don't Care			Character Bitmap				
0	1	1	0	0	0	-	-	-	0	█	0	█	0
0	1	1	0	0	1	-	-	-	█	0	█	0	█
0	1	1	0	1	0	-	-	-	0	█	0	█	0
0	1	1	0	1	1	-	-	-	█	0	█	0	█
0	1	1	1	0	0	-	-	-	0	█	0	█	0
0	1	1	1	0	1	-	-	-	█	0	█	0	█
0	1	1	1	1	0	-	-	-	0	█	0	█	0
0	1	1	1	1	1	-	-	-	0	0	0	0	0

Figure 5-5: Example Custom Checkerboard Character with Character Code 0x03

Command Set

[Table 5-2](#) summarizes the available LCD controller commands and bit definitions. Because the display is set up for four-bit operation, each eight-bit command is sent as two four-bit nibbles. The upper nibble is transferred first, followed by the lower nibble.

Table 5-2: LCD Character Display Command Set (4-bit mode)

Function	LCD_RS	LCD_RW	Upper Nibble				Lower Nibble					
			DB7	DB6	DB5	DB4	DB3	DB2	DB1	DB0		
Clear Display	0	0	0	0	0	0	0	0	0	0	1	
Return Cursor Home	0	0	0	0	0	0	0	0	0	0	1	-
Entry Mode Set	0	0	0	0	0	0	0	0	0	1	I/D	S
Display On/Off	0	0	0	0	0	0	0	1	D	C	B	
Cursor and Display Shift	0	0	0	0	0	1	S/C	R/L	-	-	-	-

Table 5-2: LCD Character Display Command Set (4-bit mode) (Continued)

Function	LCD_RS	LCD_RW	Upper Nibble				Lower Nibble			
			DB7	DB6	DB5	DB4	DB3	DB2	DB1	DB0
Function Set	0	0	0	0	1	0	1	0	-	-
Set CG RAM Address	0	0	0	1	A5	A4	A3	A2	A1	A0
Set DD RAM Address	0	0	1	A6	A5	A4	A3	A2	A1	A0
Read Busy Flag and Address	0	1	BF	A6	A5	A4	A3	A2	A1	A0
Write Data to CG RAM or DD RAM	1	0	D7	D6	D5	D4	D3	D2	D1	D0
Read Data from CG RAM or DD RAM	1	1	D7	D6	D5	D4	D3	D2	D1	D0

Disabled

If the LCD_E enable signal is Low, all other inputs to the LCD are ignored.

Clear Display

Clears the display and returns the cursor to the home position, the top-left corner.

This command writes a blank space (ASCII/ANSI character code 0x20) into all DD RAM addresses. The address counter is reset to 0, location 0x00 in DD RAM. Clears all option settings. The I/D control bit is set to 1 (increment address counter mode) in the [Entry Mode Set](#) command.

Execution Time: 82 μs – 1.64 ms

Return Cursor Home

Returns the cursor to the home position, the top-left corner. DD RAM contents are unaffected. Also returns the display being shifted to the original position, shown in [Figure 5-3](#).

The address counter is reset to 0, location 0x00 in DD RAM. The display is returned to its original status if it was shifted. The cursor or blink move to the top-left character location.

Execution Time: 40 μs – 1.6 ms

Entry Mode Set

Sets the cursor move direction and specifies whether or not to shift the display.

These operations are performed during data reads and writes.

Execution Time: 40 μs

Bit DB1: (I/D) Increment/Decrement

0	Auto-decrement address counter. Cursor/blink moves to left.
1	Auto-increment address counter. Cursor/blink moves to right.

This bit either auto-increments or auto-decrements the DD RAM and CG RAM address counter by one location after each [Write Data to CG RAM or DD RAM](#) command or [Read](#)

Data from CG RAM or DD RAM command. The cursor or blink position moves accordingly.

Bit DB0: (S) Shift

0	Shifting disabled
1	During a DD RAM write operation, shift the entire display value in the direction controlled by Bit DB1 (I/D). It appears as though the cursor position remains constant and the display moves.

Display On/Off

The display is turned on or off, controlling all characters. The cursor and cursor position character (underscore) blink.

Execution Time: 40 μ s

Bit DB2: (D) Display On/Off

0	No characters displayed. However, data stored in DD RAM is retained.
1	Display characters stored in DD RAM

Bit DB1: (C) Cursor On/Off

The cursor uses the five dots on the bottom line of the character. The cursor appears as a line under the displayed character.

0	No cursor
1	Display cursor

Bit DB0: (B) Cursor Blink On/Off

0	No cursor blinking
1	Cursor blinks on and off approximately every half second

Cursor and Display Shift

Moves the cursor and shifts the display without changing DD RAM contents. Shift cursor position or display to the right or left without writing or reading display data.

This function positions the cursor in order to modify an individual character, or to scroll the display window left or right to reveal additional data stored in the DD RAM, beyond the 16th character on a line. The cursor automatically moves to the second line when it shifts beyond the 40th character location of the first line. The first and second line displays shift at the same time.

When the displayed data is shifted repeatedly, both lines move horizontally. The second display line does not shift into the first display line.

Execution Time: 40 μ s

Table 5-3: Shift Patterns According to S/C and R/L Bits

DB3 (S/C)	DB2 (R/L)	Operation
0	0	Shift the cursor position to the left. The address counter is decremented by one.
0	1	Shift the cursor position to the right. The address counter is incremented by one.
1	0	Shift the entire display to the left. The cursor follows the display shift. The address counter is unchanged.
1	1	Shift the entire display to the right. The cursor follows the display shift. The address counter is unchanged.

Function Set

Sets the interface data length, the number of display lines, and the character font.

The Starter Kit board supports a single function set with value 0x28.

Execution Time: 40 μ s

Set CG RAM Address

Sets the initial CG RAM address.

After this command, all subsequent read or write operations to the display are to or from CG RAM.

Execution Time: 40 μ s

Set DD RAM Address

Sets the initial DD RAM address.

After this command, all subsequent read or write operations to the display are to or from DD RAM. The addresses for displayed characters appear in [Figure 5-3](#).

Execution Time: 40 μ s

Read Busy Flag and Address

Reads the Busy flag (BF) to determine if an internal operation is in progress, and reads the current address counter contents.

BF = 1 indicates that an internal operation is in progress. The next instruction is not accepted until BF is cleared or until the current instruction is allowed the maximum time to execute.

This command also returns the present value of the address counter. The address counter is used for both CG RAM and DD RAM addresses. The specific context depends on the most recent [Set CG RAM Address](#) or [Set DD RAM Address](#) command issued.

Execution Time: 1 μ s

Write Data to CG RAM or DD RAM

Writes data into DD RAM if the command follows a previous [Set DD RAM Address](#) command, or writes data into CG RAM if the command follows a previous [Set CG RAM Address](#) command.

After the write operation, the address is automatically incremented or decremented by 1 according to the [Entry Mode Set](#) command. The entry mode also determines display shift.

Execution Time: 40 μ s

Read Data from CG RAM or DD RAM

Reads data from DD RAM if the command follows a previous [Set DD RAM Address](#) command, or reads data from CG RAM if the command follows a previous [Set CG RAM Address](#) command.

After the read operation, the address is automatically incremented or decremented by 1 according to the [Entry Mode Set](#) command. However, a display shift is not executed during read operations.

Execution Time: 40 μ s

Operation

The board has an eight-bit data interface to the character LCD. Other Xilinx boards use a four-bit interface. As shown in [Figure 5-1](#), the Spartan-3A/3AN Starter Kit board supports both an eight-bit and a four-bit interface for compatibility reasons. Many existing reference designs are already built around a four-bit interface.

Four-Bit Data Interface

[Figure 5-6](#) illustrates a write operation to the LCD, showing the minimum times allowed for setup, hold, and enable pulse length relative to the 50 MHz clock (20 ns period) provided on the board.

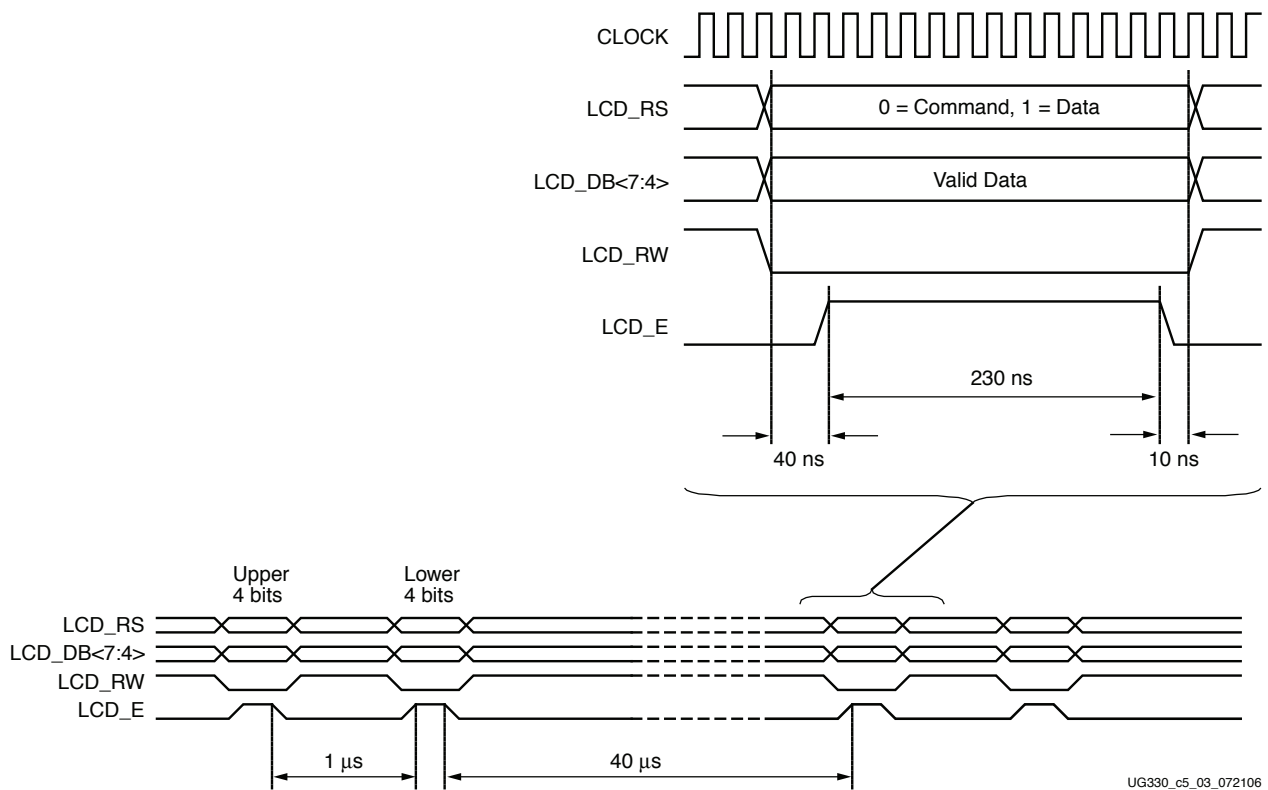

Figure 5-6: Character LCD Interface Timing

The data values on LCD_DB<7:4>, and the register select (LCD_RS) and the read/write (LCD_RW) control signals must be set up and stable at least 40 ns before the enable LCD_E goes High. The enable signal must remain High for 230 ns or longer—the equivalent of 12 or more clock cycles at 50 MHz.

In many applications, the LCD_RW signal can be tied Low permanently because the FPGA generally has no reason to read information from the display.

Transferring Eight-Bit Data over the Four-Bit Interface

After initializing the display and establishing communication in four-bit mode, all commands and data transfers to the character display are via eight bits, transferred using two sequential four-bit operations. Each eight-bit transfer must be decomposed into two four-bit transfers, spaced apart by at least 1 µs, as shown in Figure 5-6. The upper nibble is transferred first, followed by the lower nibble. An eight-bit write operation must be spaced least 40 µs before the next communication. This delay must be increased to 1.64 ms following a Clear Display command.

Initializing the Display

After power-on, the display must be initialized to establish the required communication protocol. The initialization sequence is simple and ideally suited to the highly-efficient eight-bit PicoBlaze embedded controller. After initialization, the PicoBlaze controller is available for more complex control or computation beyond simply driving the display.

Power-On Initialization

The initialization sequence first establishes that the FPGA application wishes to use the four-bit data interface to the LCD as follows:

1. Wait 15 ms or longer, although the display is generally ready when the FPGA finishes configuration. The 15 ms interval is 750,000 clock cycles at 50 MHz.
2. Write LCD_DB<7:4> = 0x3, and pulse LCD_E High for 12 clock cycles.
3. Wait 4.1 ms or longer, which is 205,000 clock cycles at 50 MHz.
4. Write LCD_DB<7:4> = 0x3, and pulse LCD_E High for 12 clock cycles.
5. Wait 100 μ s or longer, which is 5,000 clock cycles at 50 MHz.
6. Write LCD_DB<7:4> = 0x3, and pulse LCD_E High for 12 clock cycles.
7. Wait 40 μ s or longer, which is 2,000 clock cycles at 50 MHz.
8. Write LCD_DB<7:4> = 0x2, and pulse LCD_E High for 12 clock cycles.
9. Wait 40 μ s or longer, which is 2,000 clock cycles at 50 MHz.

Display Configuration

After the power-on initialization is completed, the four-bit interface is established. The next part of the sequence configures the display:

1. Issue a [Function Set](#) command, 0x28, to configure the display for operation on the Spartan-3A/3AN Starter Kit board.
2. Issue an [Entry Mode Set](#) command, 0x06, to set the display to automatically increment the address pointer.
3. Issue a [Display On/Off](#) command, 0x0C to turn the display on and disable the cursor and blinking.
4. Finally, issue a [Clear Display](#) command. Allow at least 1.64 ms (82,000 clock cycles) after issuing this command.

Writing Data to the Display

To write data to the display, specify the start address, followed by one or more data values.

Before writing any data, issue a [Set DD RAM Address](#) command to specify the initial seven-bit address in the DD RAM. See [Figure 5-3](#) for DD RAM locations.

Write data to the display using a [Write Data to CG RAM or DD RAM](#) command. The eight-bit data value represents the look-up address into the CG ROM or CG RAM, shown in [Figure 5-4](#). The stored bitmap in the CG ROM or CG RAM drives the 5 x 8 dot matrix to represent the associated character.

If the address counter is configured to auto-increment, as described earlier, the application can sequentially write multiple character codes, and each character is automatically stored and displayed in the next available location.

Continuing to write characters, however, eventually falls off the end of the first display line. The additional characters do not automatically appear on the second line because the DD RAM map is not consecutive from the first line to the second.

Disabling the Unused LCD

If the FPGA application does not use the character LCD screen, drive the LCD_E pin Low to disable it. Also drive the LCD_RW pin Low to prevent the LCD screen from presenting data.

Related Resources

Refer to the following links for additional information:

- **PowerTip PC1602-D Character LCD (Basic Electrical and Mechanical Data)**
www.powertipusa.com/pdf/pc1602d.pdf
- **Sitronix ST7066U Character LCD Controller**
www.samsung.com/global/business/semiconductor/productInfo.do?fmly_id=204&partnum=S6A0069
- **Samsung S6A0069X Character LCD Controller**
www.samsung.com/Products/Semiconductor/DisplayDriverIC/MobileDDI/BWSTN/S6A0069X/S6A0069X.htm
- **Design Example: Device DNA Reader and LCD Display Controller**
www.xilinx.com/products/boards/s3astarter/reference_designs.htm#dna_reader

VGA Display Port

The Spartan®-3A/3AN FPGA Starter Kit board includes a VGA display port via a standard high-density HD-DB15 female connector. Connect this port directly to most PC monitors or flat-panel LCDs using a standard monitor cable. As shown in Figure 6-1, the VGA connector is the left-most connector along the top of the board.

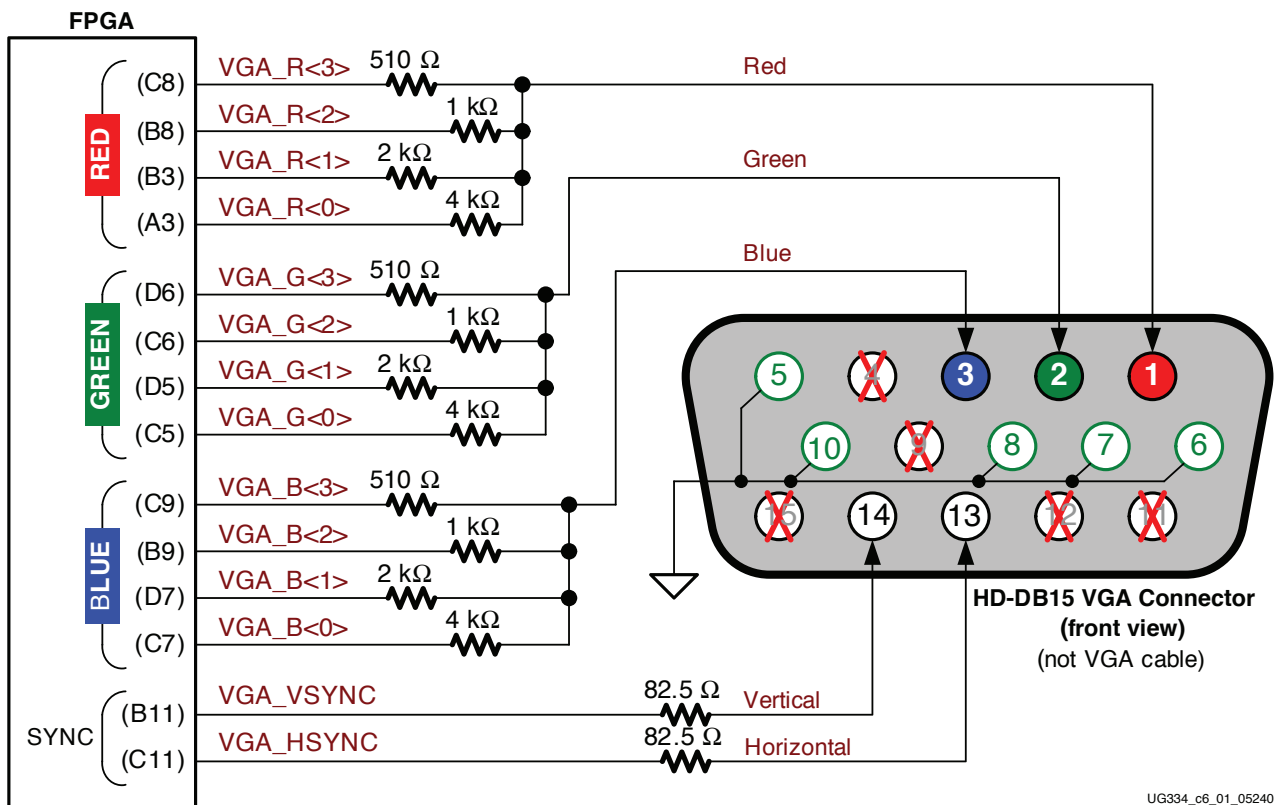
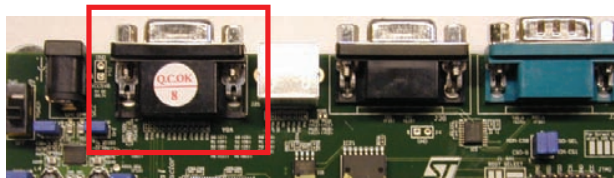

Figure 6-1: VGA Connections from the Starter Kit Board

The FPGA directly drives the five VGA signals via resistors. Each red, green, and blue signal has four outputs from the FPGA that feed a resistor-divider tree. This approach

provides 4-bit resolution per color, generating 12-bit color, or 4,096 possible colors. The series resistor, in combination with the 75Ω termination built into the VGA cable, ensures that the color signals remain in the VGA-specified 0V to 0.7V range.

The VGA_HSYNC and VGA_VSYNC signals use LVTTTL or LVCMOS33 I/O standard drive levels.

Drive the VGA_R[3:0], VGA_G[3:0], and VGA_B[3:0] signals High or Low to generate the desired colors. The scaled analog output is generated by a resistor-divider that converts the FPGA's digital outputs for an individual color. Each individual color output supports 16 possible values, as described by [Equation 6-1](#). The three separate controls for red, green, and blue support a maximum of 12-bit color, or 4,096 values.

$$COLOR_{OUT} = \frac{VGA[3:0]}{15} \times COLOR \quad \text{Equation 6-1}$$

For simplicity, the FPGA application can also treat the VGA port as a three-bit interface by driving all four color outputs with the same digital value. The corresponding eight basic color values are shown in [Table 6-1](#).

Table 6-1: Example Display Color Codes

VGA_R[3:0]	VGA_G[3:0]	VGA_B[4:0]	Resulting Color
0000	0000	0000	Black
0000	0000	1111	Blue
0000	1111	0000	Green
0000	1111	1111	Cyan
1111	0000	0000	Red
1111	0000	1111	Magenta
1111	1111	0000	Yellow
1111	1111	1111	White

Signal Timing for a 60 Hz, 640x480 VGA Display

VGA signal timing is specified, published, copyrighted, and sold by the Video Electronics Standards Association (VESA). The following VGA system and timing information is provided as an example of how the FPGA might drive the VGA monitor in 640 by 480 mode. For more precise information or for information on higher VGA frequencies, refer to documents available on the VESA website or other electronics websites (see [“Related Resources,” page 61](#)). Standard VGA support is part of the factory demonstration designs, but several extended VGA modes including SVGA are also achievable with faster timing controllers.

CRT-based VGA displays use amplitude-modulated, moving electron beams (or cathode rays) to display information on a phosphor-coated screen. LCDs use an array of switches that can impose a voltage across a small amount of liquid crystal, thereby changing light permittivity through the crystal on a pixel-by-pixel basis. Although the following description is limited to CRT displays, LCDs have evolved to use the same signal timings as CRT displays. Consequently, the following discussion pertains to both CRTs and LCDs.

Within a CRT display, current waveforms pass through the coils to produce magnetic fields that deflect electron beams to transverse the display surface in a *raster* pattern, horizontally from left to right and vertically from top to bottom. As shown in Figure 6-2, information is only displayed when the beam is moving in the *forward* direction—left to right and top to bottom—and not during the time the beam returns back to the left or top edge of the display. Much of the potential display time is therefore lost in *blanking* periods when the beam is reset and stabilized to begin a new horizontal or vertical display pass.

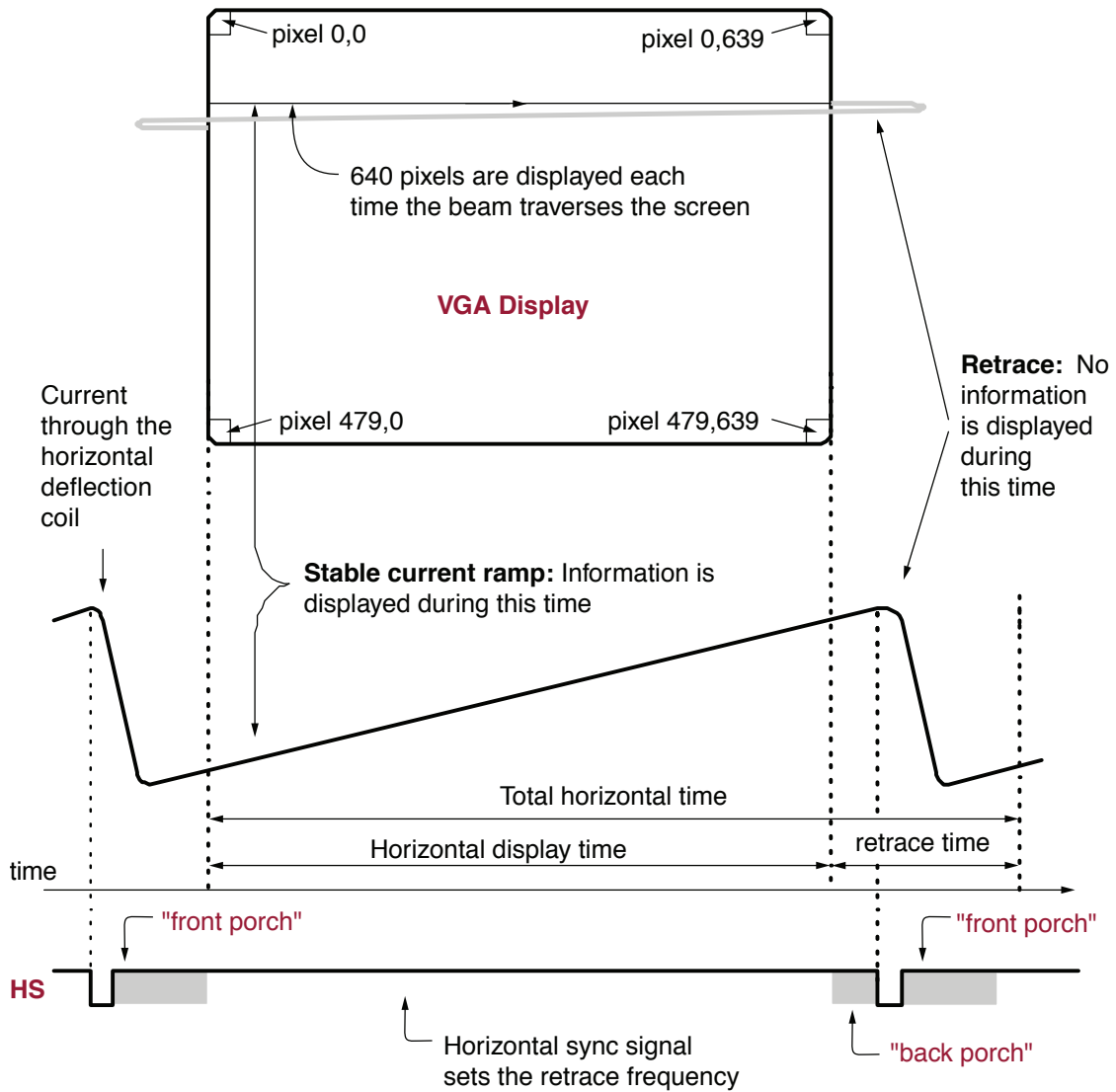

UG230_c6_02_021706

Figure 6-2: CRT Display Timing Example

The display resolution defines the size of the beams, the frequency at which the beam traces across the display, and the frequency at which the electron beam is modulated.

Modern VGA displays support multiple display resolutions, and the VGA controller dictates the resolution by producing timing signals to control the raster patterns. The controller produces TTL-level synchronizing pulses that set the frequency at which current

flows through the deflection coils, and it ensures that pixel or video data is applied to the electron guns at the correct time.

Video data typically comes from a video refresh memory with one or more bytes assigned to each pixel location. The Spartan-3A/3AN Starter Kit board uses 12 bits per pixel, producing one of the 4,096 possible colors. The controller indexes into the video data buffer as the beams move across the display. The controller then retrieves and applies video data to the display at precisely the time the electron beam is moving across a given pixel.

As shown in Figure 6-2, the VGA controller generates the horizontal sync (HS) and vertical sync (VS) timing signals and coordinates the delivery of video data on each pixel clock. The pixel clock defines the time available to display one pixel of information. The VS signal defines the *refresh* frequency of the display, or the frequency at which all information on the display is redrawn. The minimum refresh frequency is a function of the display's phosphor and electron beam intensity, with practical refresh frequencies in the 60 Hz to 120 Hz range. The number of horizontal lines displayed at a given refresh frequency defines the horizontal *retrace* frequency.

VGA Signal Timing

The signal timings in Table 6-2 are derived for a 640-pixel by 480-row display using a 25 MHz pixel clock and 60 Hz ± 1 refresh. Figure 6-3 shows the relation between each of the timing symbols. The timing for the sync pulse width (T_{PW}) and front and back porch intervals (T_{FP} and T_{BP}) is based on observations from various VGA displays. The front and back porch intervals are the pre- and post-sync pulse times. Information cannot be displayed during these times.

Table 6-2: 640x480 Mode VGA Timing

Symbol	Parameter	Vertical Sync			Horizontal Sync	
		Time	Clocks	Lines	Time	Clocks
T_S	Sync pulse time	16.7 ms	416,800	521	32 μ s	800
T_{DISP}	Display time	15.36 ms	384,000	480	25.6 μ s	640
T_{PW}	Pulse width	64 μ s	1,600	2	3.84 μ s	96
T_{FP}	Front porch	320 μ s	8,000	10	640 ns	16
T_{BP}	Back porch	928 μ s	23,200	29	1.92 μ s	48

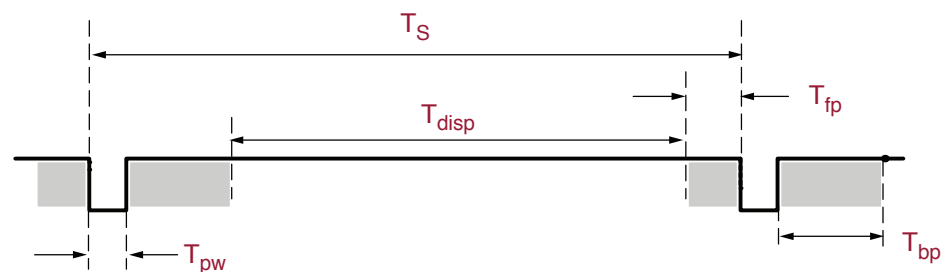

UG230_c6_03_021706

Figure 6-3: VGA Control Timing

Generally, a counter clocked by the pixel clock controls the horizontal timing. Decoded counter values generate the HS signal. This counter tracks the current pixel display location on a given row.

A separate counter tracks the vertical timing. The vertical-sync counter increments with each HS pulse, and decoded values generate the VS signal. This counter tracks the current display row. These two continuously running counters form the address into a video display buffer. For example, the on-board DDR2 SDRAM provides an ideal display buffer.

No time relationship is specified between the onset of the HS pulse and the onset of the VS pulse. Consequently, the counters can be arranged to easily form video RAM addresses or to minimize decoding logic for sync pulse generation.

UCF Location Constraints

Figure 6-4 provides the UCF constraints for the VGA display port, including the I/O pin assignment, the I/O standard used, the output slew rate, and the output drive current.

```

NET "VGA_R<3>" LOC = "C8" | IOSTANDARD = LVCMOS33 | DRIVE = 8 | SLEW = FAST ;
NET "VGA_R<2>" LOC = "B8" | IOSTANDARD = LVCMOS33 | DRIVE = 8 | SLEW = FAST ;
NET "VGA_R<1>" LOC = "B3" | IOSTANDARD = LVCMOS33 | DRIVE = 8 | SLEW = FAST ;
NET "VGA_R<0>" LOC = "A3" | IOSTANDARD = LVCMOS33 | DRIVE = 8 | SLEW = FAST ;
NET "VGA_G<3>" LOC = "D6" | IOSTANDARD = LVCMOS33 | DRIVE = 8 | SLEW = FAST ;
NET "VGA_G<2>" LOC = "C6" | IOSTANDARD = LVCMOS33 | DRIVE = 8 | SLEW = FAST ;
NET "VGA_G<1>" LOC = "D5" | IOSTANDARD = LVCMOS33 | DRIVE = 8 | SLEW = FAST ;
NET "VGA_G<0>" LOC = "C5" | IOSTANDARD = LVCMOS33 | DRIVE = 8 | SLEW = FAST ;
NET "VGA_B<3>" LOC = "C9" | IOSTANDARD = LVCMOS33 | DRIVE = 8 | SLEW = FAST ;
NET "VGA_B<2>" LOC = "B9" | IOSTANDARD = LVCMOS33 | DRIVE = 8 | SLEW = FAST ;
NET "VGA_B<1>" LOC = "D7" | IOSTANDARD = LVCMOS33 | DRIVE = 8 | SLEW = FAST ;
NET "VGA_B<0>" LOC = "C7" | IOSTANDARD = LVCMOS33 | DRIVE = 8 | SLEW = FAST ;
NET "VGA_HSYNC" LOC = "C11" | IOSTANDARD = LVCMOS33 | DRIVE = 8 | SLEW = FAST ;
NET "VGA_VSYNC" LOC = "B11" | IOSTANDARD = LVCMOS33 | DRIVE = 8 | SLEW = FAST ;

```

Figure 6-4: UCF Constraints for VGA Display Port

Related Resources

Refer to the following links for additional information:

- **VESA**
www.vesa.org
- **VGA timing information**
www.epanorama.net/documents/pc/vga_timing.html

RS-232 Serial Ports

Overview

As shown in Figure 7-1, the Spartan®-3A/3AN FPGA Starter Kit board has two RS-232 serial ports: a female DB9 DCE connector and a male DB9 DTE connector. The DCE-style port connects directly to the serial port connector available on most personal computers and workstations via a standard straight-through serial cable. For typical applications, the board does not require null modem cables, gender changers, or crossover cables.

Use the DTE-style connector to control other RS-232 peripherals, such as modems or printers, or perform simple loopback testing with the DCE connector.

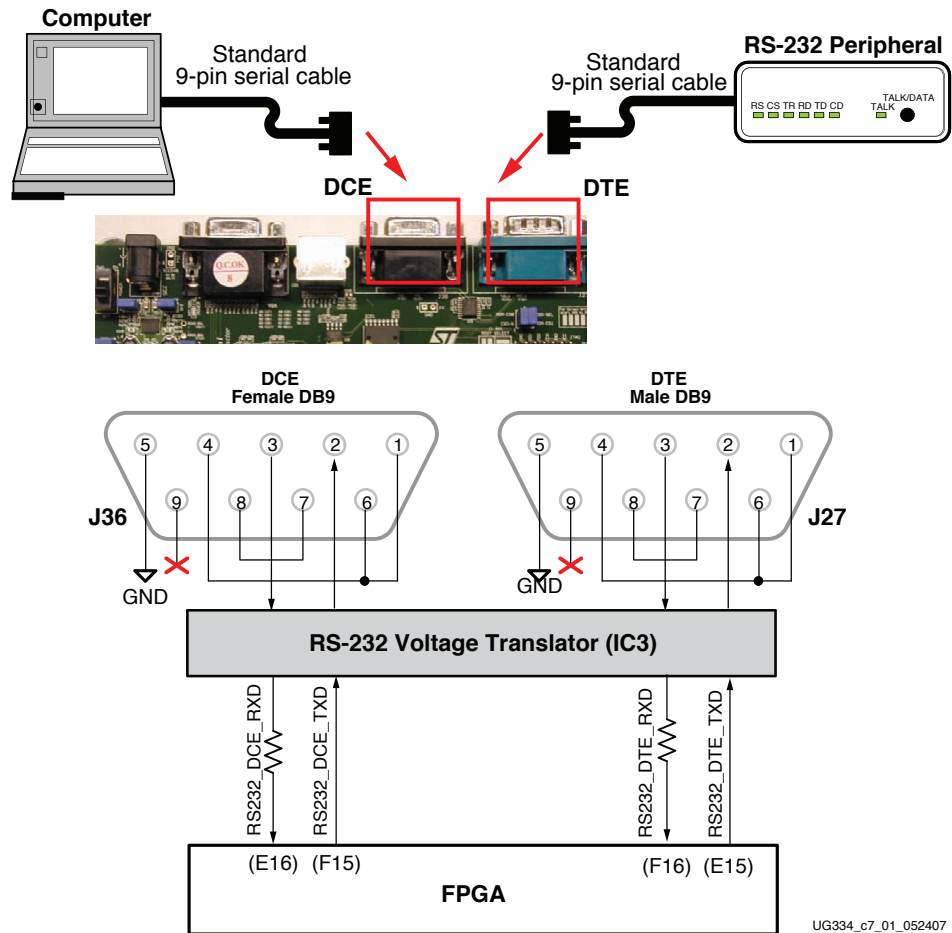

Figure 7-1: RS-232 Serial Ports

UG334_c7_01_052407

Figure 7-1 shows the connection between the FPGA and the two DB9 connectors. The FPGA supplies serial output data using LVTTTL or LVCMOS levels to the Maxim device, which in turn, converts the logic value to the appropriate RS-232 voltage level. Likewise, the Maxim device converts the RS-232 serial input data to LVTTTL levels for the FPGA. A series resistor between the Maxim output pin and the FPGA's RXD pin protects against inadvertent logic conflicts such as accidentally connecting the board using a null-modem cable. In this example, both the FPGA and the external serial device are driving data on the transmit line.

Hardware flow control is not supported on the connector. The port's DCD, DTR, and DSR signals connect together, as shown in Figure 7-1. Similarly, the port's RTS and CTS signals connect together.

UCF Location Constraints

Figure 7-2 and Figure 7-3 provide the UCF constraints for the DTE and DCE RS-232 ports, respectively, including the I/O pin assignment and the I/O standard used.

```
NET "RS232_DTE_RXD" LOC = "F16" | IOSTANDARD = LVCMOS33 ;
NET "RS232_DTE_TXD" LOC = "E15" | IOSTANDARD = LVCMOS33 | DRIVE = 8 | SLEW = SLOW ;
```

Figure 7-2: UCF Location Constraints for DTE RS-232 Serial Port

```
NET "RS232_DCE_RXD" LOC = "E16" | IOSTANDARD = LVCMOS33 ;
NET "RS232_DCE_TXD" LOC = "F15" | IOSTANDARD = LVCMOS33 | DRIVE = 8 | SLEW = SLOW ;
```

Figure 7-3: UCF Location Constraints for DCE RS-232 Serial Port

PS/2 Mouse/Keyboard Port

The Spartan®-3A/3AN FPGA Starter Kit board includes a PS/2 mouse/keyboard port and the standard six-pin mini-DIN connector, labeled J28 on the board. Figure 8-1 shows the PS/2 connector, and Table 8-1 shows the signals on the connector. Use the primary connections indicated to connect a mouse or keyboard directly to the board. Also see “Adding a Second PS/2 Port Using a Y-Splitter Cable,” page 69.

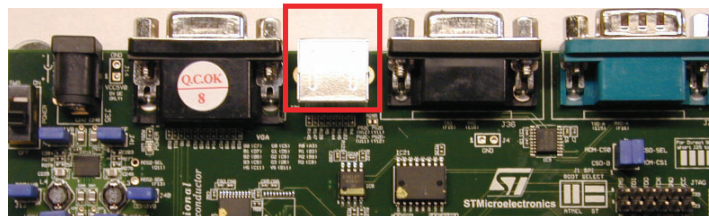
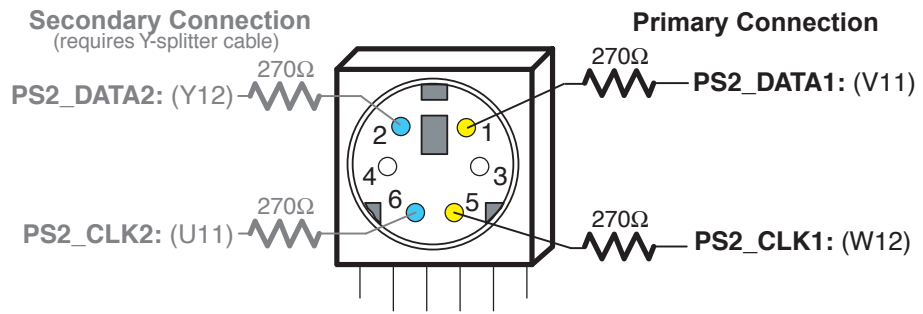

UG334_c8_01_052407

Figure 8-1: PS/2 Connector Location and Signals

Table 8-1: PS/2 Connector Pinout

PS/2 DIN Pin	Signal	FPGA Pin
1	Primary data connection PS2_DATA1	V11
2	Secondary data connection when using PS/2 splitter cable PS2_DATA2	Y12
3	GND	GND
4	+5V	No Connection
5	Primary clock connection PS2_CLK1	W12
6	Secondary data connection with using PS/2 splitter cable PS2_CLK2	U11

The PS/2 port I/Os should always be set to LVCMOS33 with the PULLUP attribute set true when used. If this attribute is not set, the voltage on the PS/2 I/Os will be greater than the maximum specified permissible amount in the data sheet. These I/Os can be damaged if the bitstream option for unused I/Os is set to float and the FPGA design is not using the PS/2 port pins.

Both a PC mouse and keyboard use the two-wire PS/2 serial bus to communicate with a host device, the FPGA in this case. The PS/2 bus includes both clock and data. Both a mouse and keyboard drive the bus with identical signal timings, and both use 11-bit words that include a start, a stop, and an odd parity bit. However, the data packets are organized differently for a mouse and keyboard. Both the keyboard and mouse interfaces allow bidirectional data transfers. For example, the FPGA host design can illuminate the state LEDs on the keyboard or change the communicate rate with the mouse.

The PS/2 bus timing appears in Table 8-2 and Figure 8-2. The clock and data signals are only driven when data transfers occur; otherwise they are held in the idle state at a logic High. The timing defines signal requirements for mouse-to-host communications and bidirectional keyboard communications. As shown in Figure 8-2, the attached keyboard or mouse writes a bit on the data line when the clock signal is High, and the host reads the data line when the clock signal is Low.

Table 8-2: PS/2 Bus Timing

Symbol	Parameter	Min	Max
T_{CK}	Clock High or Low Time	30 μ s	50 μ s
T_{SU}	Data-to-clock Setup Time	5 μ s	25 μ s
T_{HLD}	Clock-to-data Hold Time	5 μ s	25 μ s

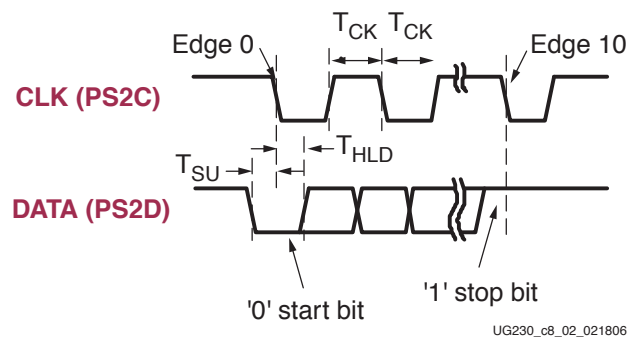

UG230_c8_02_021806

Figure 8-2: PS/2 Bus Timing Waveforms

Keyboard

The keyboard uses open-collector drivers so that either the device or the host can drive the two-wire bus. If the host never sends data, then the host can use simple input pins.

A PS/2-style keyboard uses scan codes to communicate key-press data. Each key has a single, unique scan code that is sent whenever the corresponding key is pressed. The scan codes for most keys appear in Figure 8-3.

If the key is pressed and held, the keyboard repeatedly sends the scan code every 100 ms or so. When a key is released, the keyboard sends an "F0" key-up code, followed by the scan code of the released key. The keyboard sends the same scan code, regardless if a key has

different *shift* and *non-shift* characters and regardless whether the Shift key is pressed or not. The host determines which character is intended.

Some keys, called extended keys, send an “E0” ahead of the scan code, and furthermore, they might send more than one scan code. When an extended key is released, an “E0 F0” key-up code is sent, followed by the scan code.

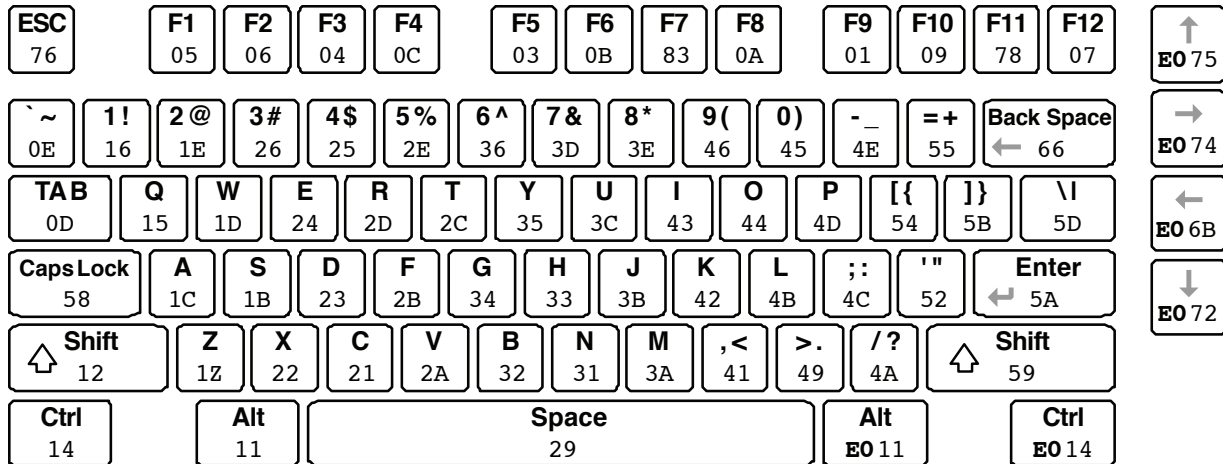

UG230_c8_03_021806

Figure 8-3: PS/2 Keyboard Scan Codes

The host can also send commands and data to the keyboard. Table 8-3 provides a short list of some often-used commands.

Table 8-3: Common PS/2 Keyboard Commands

Command	Description																
ED	<p>Turn on/off Num Lock, Caps Lock, and Scroll Lock LEDs. The keyboard acknowledges receipt of an “ED” command by replying with an “FA”, after which the host sends another byte to set LED status. The bit positions for the keyboard LEDs are shown below. Write a ‘1’ to the specific bit to illuminate the associated keyboard LED.</p> <table border="1" style="margin-left: 20px;"> <tr> <td>7</td> <td>6</td> <td>5</td> <td>4</td> <td>3</td> <td>2</td> <td>1</td> <td>0</td> </tr> <tr> <td colspan="5">Ignored</td> <td>Caps Lock</td> <td>Num Lock</td> <td>Scroll Lock</td> </tr> </table>	7	6	5	4	3	2	1	0	Ignored					Caps Lock	Num Lock	Scroll Lock
7	6	5	4	3	2	1	0										
Ignored					Caps Lock	Num Lock	Scroll Lock										
EE	Echo. Upon receiving an echo command, the keyboard replies with the same scan code “EE”.																
F3	Set scan code repeat rate. The keyboard acknowledges receipt of an “F3” by returning an “FA”, after which the host sends a second byte to set the repeat rate.																
FE	Resend. Upon receiving a resend command, the keyboard resends the last scan code.																
FF	Reset. Resets the keyboard.																

The keyboard sends commands or data to the host only when both the data and clock lines are High, the Idle state.

Because the host is the *bus master*, the keyboard checks whether the host is sending data before driving the bus. The clock line can be used as a *clear to send* signal. If the host pulls the clock line Low, the keyboard must not send any data until the clock is released.

The keyboard sends data to the host in 11-bit words that contain a '0' start bit, followed by eight bits of scan code (LSB first), followed by an odd parity bit and terminated with a '1' stop bit. When the keyboard sends data, it generates 11 clock transitions at around 20 to 30 kHz, and data is valid on the falling edge of the clock as shown in Figure 8-2.

Mouse

PS/2-compatible mice potentially support two modes. In polled mode, the host controller interrogates the mouse for activity. In streaming mode, the mouse reports any movement or key presses. Streaming mode is the default operating mode.

To specifically enter streaming mode, the FPGA host must transmit a "Set Stream Mode" command (0xEA) to the mouse. The mouse then generates a clock and data signal when moved or when one or more keys are pressed; otherwise, these signals remain High, indicating the Idle state. Each time the mouse is moved, the mouse sends three 11-bit words to the host. Each of the 11-bit words contains a '0' start bit, followed by 8 data bits (LSB first), followed by an odd parity bit, and terminated with a '1' stop bit. Each data transmission contains 33 total bits, where bits 0, 11, and 22 are '0' start bits, and bits 10, 21, and 32 are '1' stop bits. The three eight-bit data fields contain movement data as shown in Figure 8-4. Data is valid at the falling edge of the clock, and the clock period is 20 to 30 kHz.

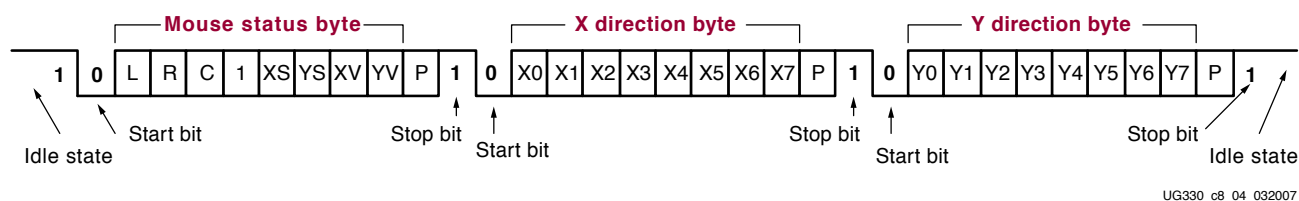

Figure 8-4: PS/2 Mouse Transaction

A PS/2-style mouse employs a relative coordinate system (see Figure 8-5), wherein moving the mouse to the right generates a positive value in the X field, and moving to the left generates a negative value. Likewise, moving the mouse up generates a positive value in the Y field, and moving it down represents a negative value. The XS and YS bits in the status byte define the sign of each value, where a '1' indicates a negative value.

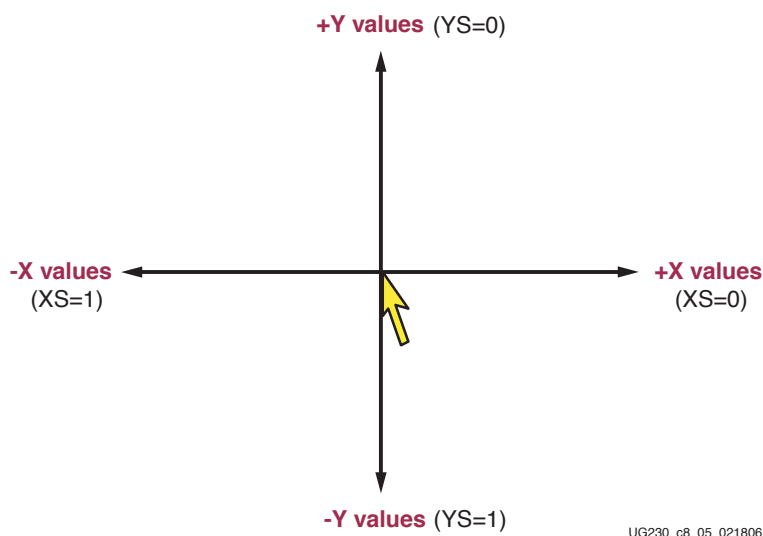

Figure 8-5: The Mouse Uses a Relative Coordinate System to Track Movement

The magnitude of the X and Y values represents the rate of mouse movement. The larger the value, the faster the mouse is moving. The XV and YV bits in the status byte indicate when the X or Y values exceed their maximum value, an overflow condition. A '1' indicates when an overflow occurs. If the mouse moves continuously, the 33-bit transmissions repeat every 50 ms or so.

The L, R, and C fields in the status byte correspond to Left, Right, and Center button presses. A '1' indicates that the associated mouse button is being pressed.

Voltage Supply

The PS/2 port on the Spartan-3A/3AN Starter Kit board is powered by 5V. Although the Spartan-3A/3AN FPGA is not a 5V-tolerant device, it can communicate with a 5V device using 270Ω series current-limiting resistors, as shown in [Figure 8-1, page 65](#).

Adding a Second PS/2 Port Using a Y-Splitter Cable

Most applications that use the PS/2 port will connect a mouse or a keyboard directly to the Spartan-3A/3AN Starter Kit board connector. These applications use the primary FPGA connections to the PS/2 port, as shown in [Figure 8-1, page 65](#).

However, it is possible to include a second PS/2 port by connecting a PS/2 Y-splitter cable to the PS/2 connector on the board. [Figure 8-6](#) shows an example of such a cable. The Spartan-3A/3AN Starter Kit does not include such a cable but one can be purchased from a local electronics supply store or via the web. Some example vendors and part numbers are listed below. Check various vendors and suppliers as prices vary greatly!

- StarTech PS/2 Keyboard/Mouse Y-splitter Cable, KYC1MF
- American Power Conversion (APC) Mouse and Keyboard Splitter Cable, 62305-1
- Belkin Pro Series Notebook Y Cable, F3G117-01
- Tripp Lite, P230-001
- QVS CC321Y
- ComputerCableStore.com, 8-1718Y-00.5
- CablesToGo, 08017



UG330_c8_02_012507

Figure 8-6: Example PS/2 Y-Splitter Cable

When using the splitter cable, use both sets of FPGA connections listed in [Figure 8-1, page 65](#) and [Table 8-1, page 65](#). The primary connections appear at one side of the Y-splitter while the secondary connections appear at the other side of the Y-splitter.

UCF Location Constraints

Figure 8-7 provides the UCF constraints for the PS/2 port connecting, including the I/O pin assignment and the I/O standard used.

```
# Primary connection
NET "PS2_CLK1" LOC = "W12" | IOSTANDARD = LVCMOS33 | DRIVE = 8 | SLEW = SLOW ;
NET "PS2_DATA1" LOC = "V11" | IOSTANDARD = LVCMOS33 | DRIVE = 8 | SLEW = SLOW ;

# Secondary connection (requires Y-splitter cable)
NET "PS2_CLK2" LOC = "U11" | IOSTANDARD = LVCMOS33 | DRIVE = 8 | SLEW = SLOW ;
NET "PS2_DATA2" LOC = "Y12" | IOSTANDARD = LVCMOS33 | DRIVE = 8 | SLEW = SLOW ;
```

Figure 8-7: UCF Location Constraints for PS/2 Port

Related Resources

Refer to the following links for additional information:

- **PS/2 Mouse/Keyboard Protocol**
www.computer-engineering.org/ps2protocol
- **PS/2 Keyboard Interface**
www.computer-engineering.org/ps2keyboard
- **PS/2 Mouse Interface**
www.computer-engineering.org/ps2mouse

Analog Capture Circuit

The Spartan®-3A/3AN FPGA Starter Kit board includes a two-channel analog capture circuit, consisting of a programmable scaling pre-amplifier and an analog-to-digital converter (ADC), as shown in [Figure 9-1](#).

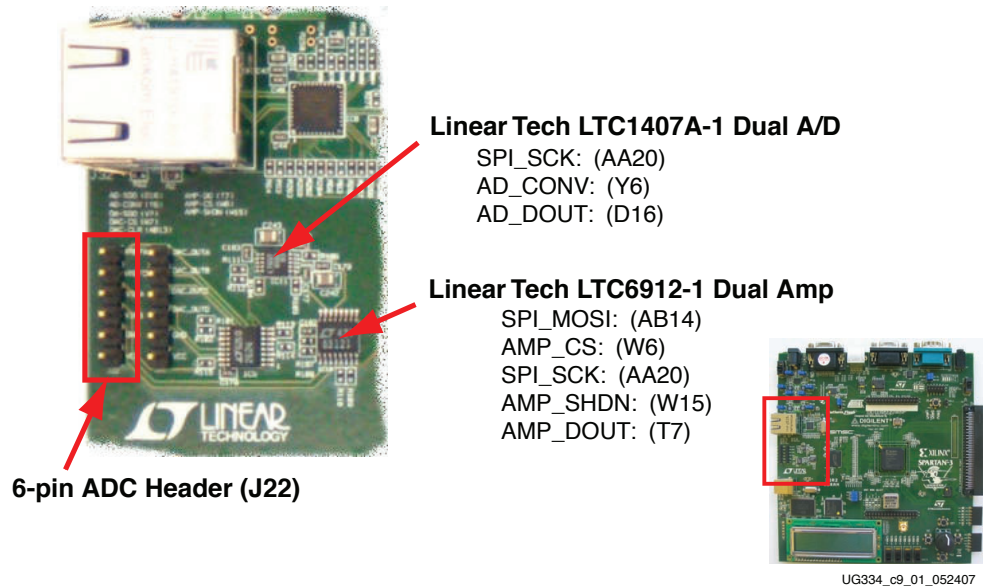
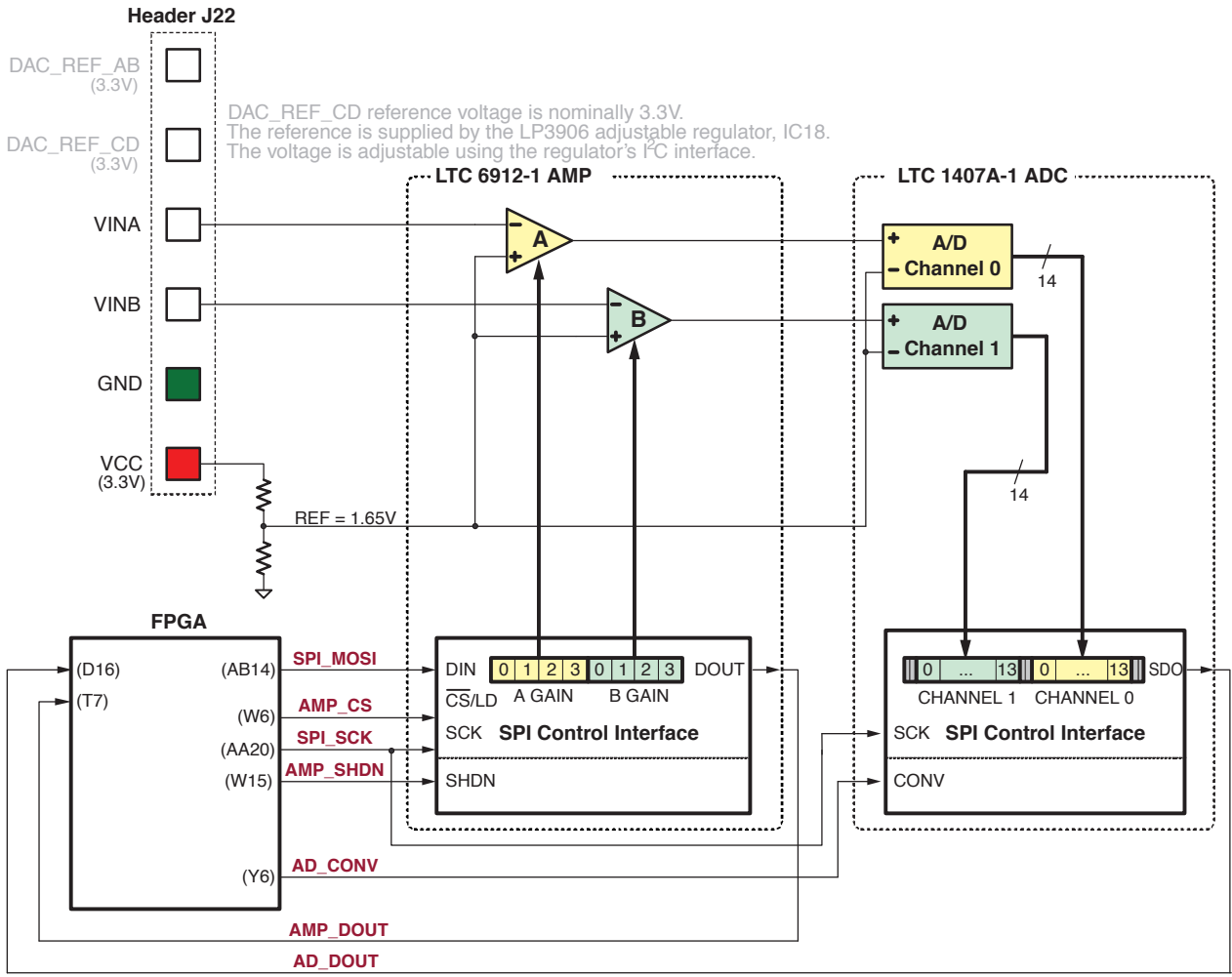

Figure 9-1: Analog Capture Circuit and Associated Stake Pin Header (J22)

The analog capture circuit consists of a Linear Technology LTC6912-1 programmable pre-amplifier that scales the incoming analog signal on the J22 header. The output of the pre-amplifier connects to a Linear Technology LTC1407A-1 ADC. Both the pre-amplifier and the ADC are serially programmed or controlled by the FPGA.



UG334_c9_02_052407

Figure 9-2: Detailed View of Analog Capture Circuit

Digital Outputs from Analog Inputs

The analog capture circuit converts the analog voltage on VINA or VINB and converts it to a 14-bit digital representation, D[13:0], as expressed by Equation 9-1.

$$D[13:0] = GAIN \times \frac{(V_{IN} - 1.65V)}{1.25V} \times 8192 \quad \text{Equation 9-1}$$

The GAIN is the current setting loaded into the programmable pre-amplifier. The various allowable settings for GAIN and allowable voltages applied to the VINA and VINB inputs appear in Table 9-2.

The reference voltage for the amplifier and the ADC is 1.65V, generated via a voltage divider shown in Figure 9-2. Consequently, 1.65V is subtracted from the input voltage on VINA or VINB.

The maximum range of the ADC is $\pm 1.25V$, centered around the reference voltage, 1.65V. Hence, 1.25V appears in the denominator to scale the analog input accordingly.

Finally, the ADC presents a 14-bit, two's complement digital output. A 14-bit, two's complement number represents values between -2^{13} and $2^{13}-1$. Therefore, the quantity is scaled by 8192, or 2^{13} .

See "[Programmable Pre-Amplifier](#)" to control the GAIN settings on the programmable pre-amplifier.

The reference design files provide more information on converting the voltage applied on VINA or VINB to a digital representation (see "[Related Resources](#)," page 77).

Programmable Pre-Amplifier

The LTC6912-1 provides two independent, inverting amplifiers with programmable gain. The purpose of the amplifier is to scale the incoming voltage on VINA or VINB so that it maximizes the conversion range of the DAC, namely $1.65 \pm 1.25V$.

Interface

[Table 9-1](#) lists the interface signals between the FPGA and the amplifier. The SPI_MOSI and SPI_SCK signals are shared with other devices on the SPI bus. The AMP_CS signal is the active-Low slave select input to the amplifier.

Table 9-1: AMP Interface Signals

Signal	FPGA Pin	Direction	Description
SPI_MOSI	AB14	FPGA → AMP	Serial data: Master Output, Slave Input. Presents eight-bit programmable gain settings, as defined in Table 9-2 .
AMP_CS	W6	FPGA → AMP	Active-Low chip select. The amplifier gain is set when the signal returns High.
SPI_SCK	AA20	FPGA → AMP	Clock
AMP_SHDN	W15	FPGA → AMP	Active-High shutdown, reset
AMP_DOUT	T7	FPGA ← AMP	Serial data. Echoes previous amplifier gain settings. Can be ignored in most applications.

Programmable Gain

Each analog channel has an associated programmable gain amplifier (see [Figure 9-2](#)). Analog signals presented on the VINA or VINB inputs on the J7 header are amplified relative to 1.65V. The 1.65V reference is generated using a voltage divider of the 3.3V voltage supply.

The gain of each amplifier is programmable from -1 to -100, as shown in [Table 9-2](#).

Table 9-2: Programmable Gain Settings for Pre-Amplifier

Gain	A3	A2	A1	A0	Input Voltage Range	
	B3	B2	B1	B0	Minimum	Maximum
0	0	0	0	0		
-1	0	0	0	1	0.4	2.9
-2	0	0	1	0	1.025	2.275

Table 9-2: Programmable Gain Settings for Pre-Amplifier (Continued)

Gain	A3	A2	A1	A0	Input Voltage Range	
	B3	B2	B1	B0	Minimum	Maximum
-5	0	0	1	1	1.4	1.9
-10	0	1	0	0	1.525	1.775
-20	0	1	0	1	1.5875	1.7125
-50	0	1	1	0	1.625	1.675
-100	0	1	1	1	1.6375	1.6625

SPI Control Interface

Figure 9-3 highlights the SPI-based communications interface with the amplifier. The gain for each amplifier is sent as an eight-bit command word, consisting of two four-bit fields. The most-significant bit, B3, is sent first.

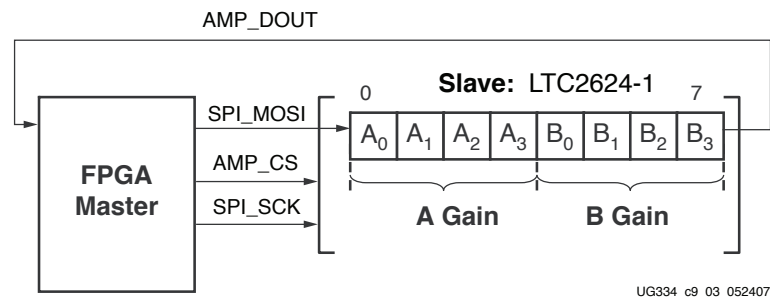

Figure 9-3: SPI Serial Interface to Amplifier

The AMP_DOUT output from the amplifier echoes the previous gain settings. These values can be ignored for most applications.

The SPI bus transaction starts when the FPGA asserts AMP_CS Low (see Figure 9-4). The amplifier captures serial data on SPI_MOSI on the rising edge of the SPI_SCK clock signal. The amplifier presents serial data on AMP_DOUT on the falling edge of SPI_SCK.

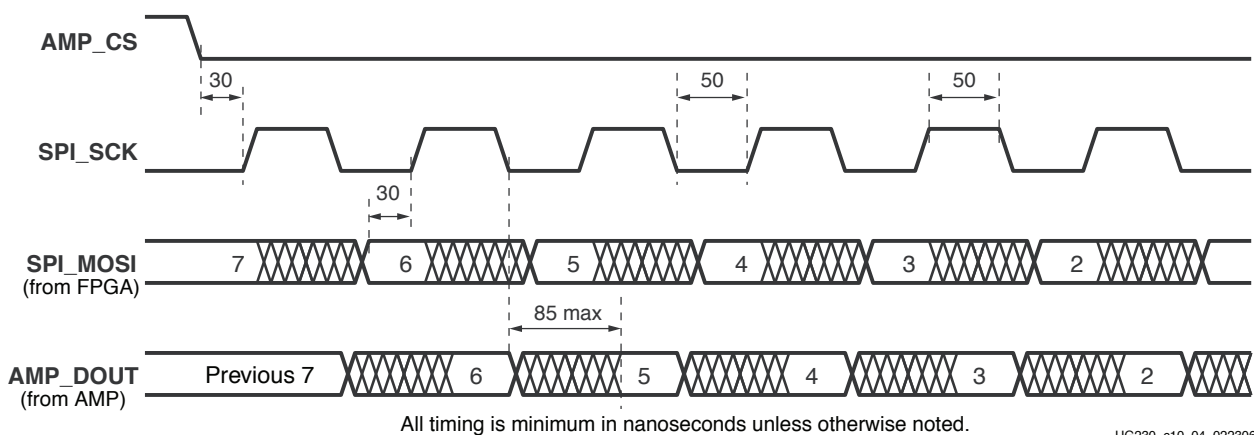

Figure 9-4: SPI Timing When Communicating with Amplifier

The amplifier interface is relatively slow, supporting only about a 10 MHz clock frequency.

UCF Location Constraints

Figure 9-5 provides the User Constraint File (UCF) constraints for the amplifier interface, including the I/O pin assignment and I/O standard used.

```
NET "SPI_MOSI" LOC = "AB14" | IOSTANDARD = LVCMOS33 | SLEW = SLOW | DRIVE = 8 ;
NET "AMP_CS" LOC = "W6" | IOSTANDARD = LVCMOS33 | SLEW = SLOW | DRIVE = 8 ;
NET "SPI_SCK" LOC = "AA20" | IOSTANDARD = LVCMOS33 | SLEW = SLOW | DRIVE = 8 ;
NET "AMP_SHDN" LOC = "W15" | IOSTANDARD = LVCMOS33 | SLEW = SLOW | DRIVE = 8 ;
NET "AMP_DOUT" LOC = "T7" | IOSTANDARD = LVCMOS33 ;
```

Figure 9-5: UCF Location Constraints for the Pre-amplifier Interface (AMP)

Analog-to-Digital Converter (ADC)

The LTC1407A-1 provides two ADCs. Both analog inputs are sampled simultaneously when the AD_CONV signal is applied.

Interface

Table 9-3 lists the interface signals between the FPGA and the ADC. The SPI_SCK signal is shared with other devices on the SPI bus. The active-High AD_CONV signal is the active-Low slave select input to the DAC. The DAC_CLR signal is the active-Low, asynchronous reset input to the DAC.

Table 9-3: ADC Interface Signals

Signal	FPGA Pin	Direction	Description
SPI_SCK	AA20	FPGA→ADC	Clock
AD_CONV	Y6	FPGA→ADC	Active-High, initiates conversion process.
ADC_OUT	D16	FPGA←ADC	Serial data. Presents the digital representation of the sample analog values as two 14-bit two's complement binary values.

SPI Control Interface

Figure 9-6 provides an example SPI bus transaction to the ADC.

When the AD_CONV signal goes High, the ADC simultaneously samples both analog channels. The results of this conversion are not presented until the next time AD_CONV is asserted, a latency of one sample. The maximum sample rate is approximately 1.5 MHz.

The ADC presents the digital representation of the sampled analog values as a 14-bit, two's complement binary value.

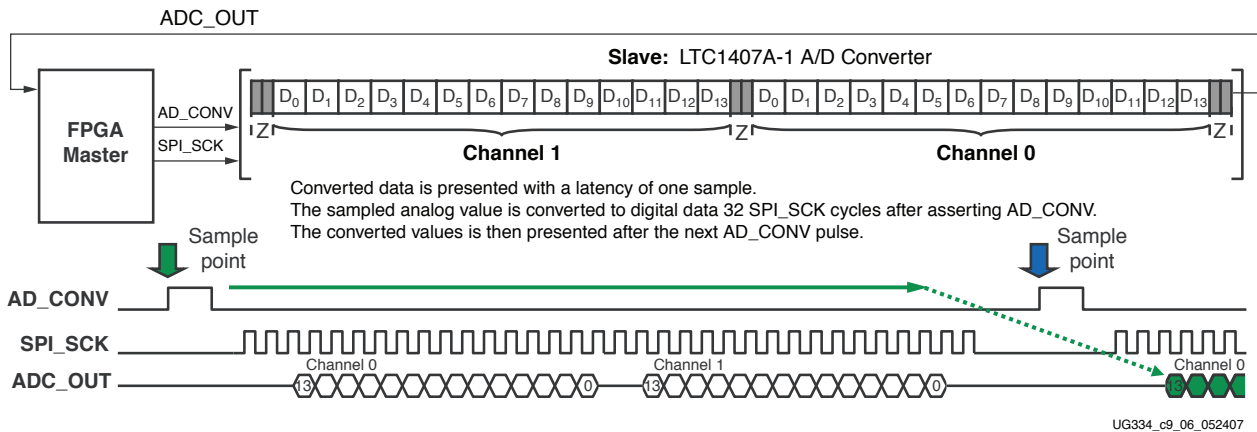

Figure 9-6: Analog-to-Digital Conversion Interface

Figure 9-7 shows detailed transaction timing. The AD_CONV signal is not a traditional SPI slave select enable. Be sure to provide enough SPI_SCK clock cycles so that the ADC leaves the ADC_OUT signal in the high-impedance state. As shown in Figure 9-6, use a 34-cycle communications sequence. The ADC 3-states its data output for two clock cycles before and after each 14-bit data transfer.

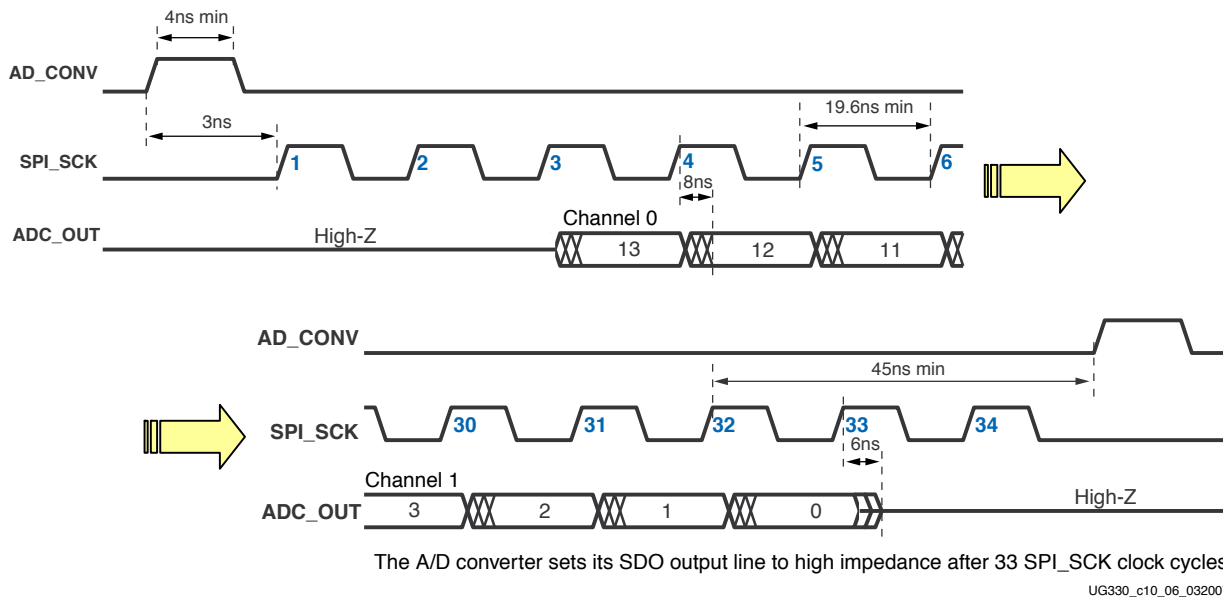

Figure 9-7: Detailed SPI Timing to ADC

UCF Location Constraints

Figure 9-8 provides the User Constraint File (UCF) constraints for the amplifier interface, including the I/O pin assignment and I/O standard used.

```
NET "AD_CONV" LOC = "Y6" | IOSTANDARD = LVCMOS33 | SLEW = SLOW | DRIVE = 8 ;
NET "SPI_SCK" LOC = "AA20" | IOSTANDARD = LVCMOS33 | SLEW = SLOW | DRIVE = 8 ;
NET "AD_DOUT" LOC = "D16" | IOSTANDARD = LVCMOS33 ;
```

Figure 9-8: UCF Location Constraints for the ADC Interface

Connecting Analog Inputs

Connect AC signals to VINA or VINB via a DC blocking capacitor.

Related Resources

Refer to the following links for additional information:

- **Xilinx PicoBlaze Soft Processor**
<http://www.xilinx.com/picoblaze>
- **LTC6912 Dual Programmable Gain Amplifiers with Serial Digital Interface**
<http://www.linear.com/pc/downloadDocument.do?navId=H0,C1,C1154,C1009,C1121,P7596,D5359>
- **LTC1407A-1 Serial 14-bit Simultaneous Sampling ADCs with Shutdown**
<http://www.linear.com/pc/downloadDocument.do?navId=H0,C1,C1155,C1001,C1158,P2420,D1295>

Digital-to-Analog Converter (DAC)

The Spartan®-3A/3AN FPGA Starter Kit board includes an SPI-compatible, four-channel, serial Digital-to-Analog Converter (DAC). The DAC device is a Linear Technology LTC2624 quad DAC with 12-bit unsigned resolution. The four outputs from the DAC appear on the J21 header, which uses the Digilent six-pin [Peripheral Module](#) format. The DAC and the header are located immediately below the Ethernet RJ-45 connector, as shown in [Figure 10-1](#).

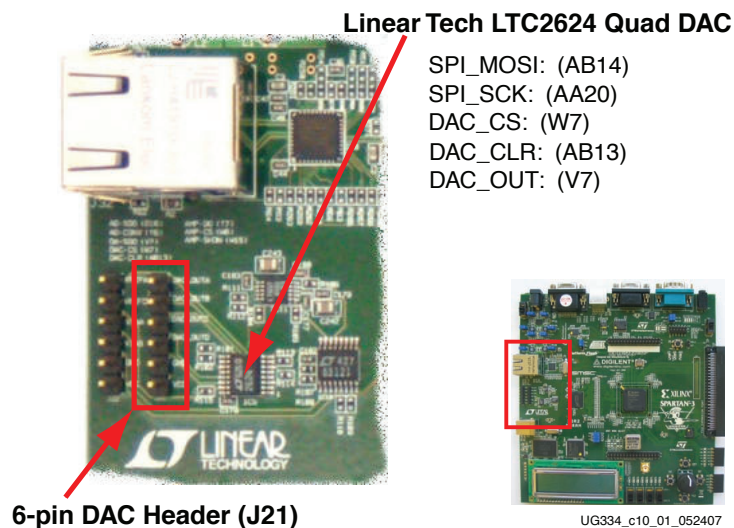

Figure 10-1: DAC and Associated Stake Pin Header (J21)

SPI Communication

As shown in [Figure 10-2](#), the FPGA uses a Serial Peripheral Interface (SPI) to communicate digital values to each of the four DAC channels. The SPI bus is a full-duplex, synchronous, character-oriented channel employing a simple four-wire interface. A bus master—the FPGA in this example—drives the bus clock signal (SPI_SCK) and transmits serial data (SPI_MOSI) to the selected bus slave—the DAC in this example. At the same time, the bus slave provides serial data (SPI_MISO) back to the bus master.

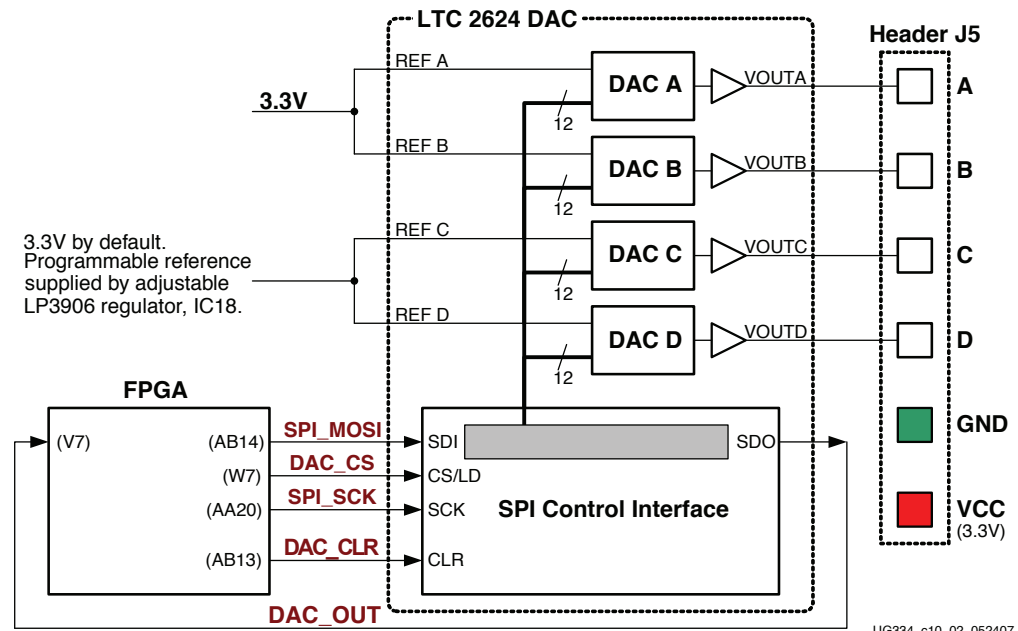

Figure 10-2: Digital-to-Analog Connection Schematics

Interface Signals

Table 10-1 lists the interface signals between the FPGA and the DAC. The SPI_MOSI, DAC_OUT, and SPI_SCK signals are shared with other devices on the SPI bus. The DAC_CS signal is the active-Low slave select input to the DAC. The DAC_CLR signal is the active-Low, asynchronous reset input to the DAC.

Table 10-1: DAC Interface Signals

Signal	FPGA Pin	Direction	Description
SPI_MOSI	AB14	FPGA→DAC	Serial data: Master Output, Slave Input
DAC_CS	W7	FPGA→DAC	Active-Low chip-select. Digital-to-analog conversion starts when this signal returns High.
SPI_SCK	AA20	FPGA→DAC	Clock
DAC_CLR	AB13	FPGA→DAC	Asynchronous, active-Low reset input
DAC_OUT	V7	FPGA←DAC	Serial data from the DAC

The serial data output from the DAC is primarily used to cascade multiple DACs. This signal can be ignored in most applications although it does demonstrate full-duplex communication over the SPI bus.

SPI Communication Details

Figure 10-3 shows a detailed example of the SPI bus timing. Each bit is transmitted or received relative to the SPI_SCK clock signal. The bus is fully static and supports clock rates up to the maximum of 50 MHz. However, check all timing parameters using the LTC2624 data sheet if operating at or close to the maximum speed.

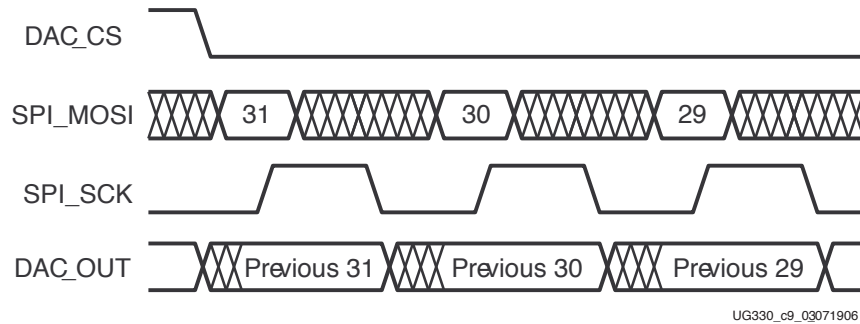

Figure 10-3: SPI Communication Waveforms

After driving the DAC_CS slave select signal Low, the FPGA transmits data on the SPI_MOSI signal, MSB first. The LTC2624 captures input data (SPI_MOSI) on the rising edge of SPI_SCK; the data must be valid for at least 4 ns relative to the rising clock edge.

The LTC2624 DAC transmits its data on the DAC_OUT signal on the falling edge of SPI_SCK. The FPGA captures this data on the next rising SPI_SCK edge. The FPGA must read the first DAC_OUT value on the first rising SPI_SCK edge after DAC_CS goes Low. Otherwise, bit 31 is missed.

After transmitting all 32 data bits, the FPGA completes the SPI bus transaction by returning the DAC_CS slave select signal High. The High-going edge starts the actual digital-to-analog conversion process within the DAC.

Communication Protocol

Figure 10-4 shows the communications protocol required to interface with the LTC2624 DAC. The DAC supports both 24-bit and 32-bit protocol. The 32-bit protocol is shown.

Inside the DAC, the SPI interface is formed by a 32-bit shift register. Each 32-bit command word consists of a command and an address, followed by a data value. As a new command enters the DAC, the previous 32-bit command word is echoed back to the master. The response from the DAC can be ignored although it is a useful to confirm correct communication.

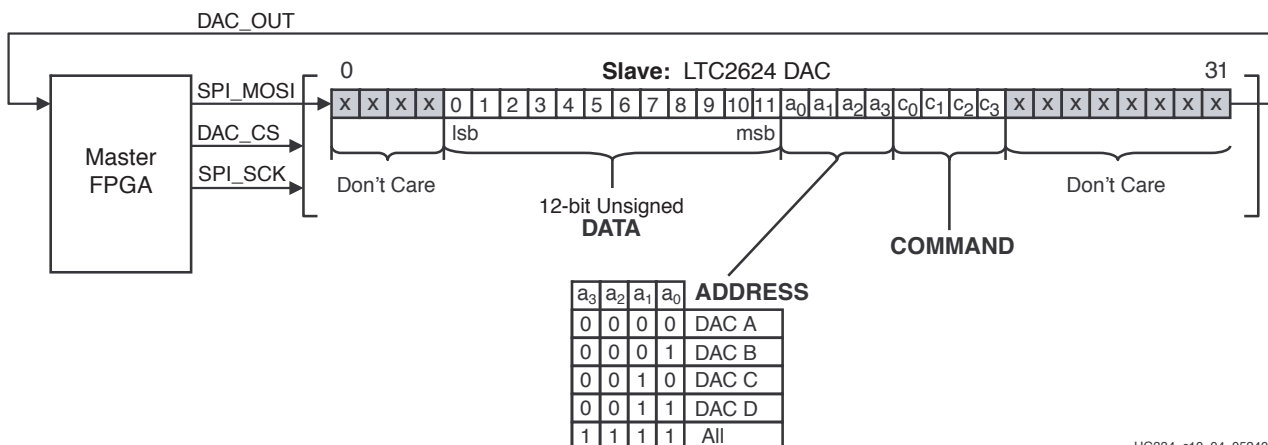

Figure 10-4: SPI Communications Protocol to LTC2624 DAC

UG334_c10_04_052407

The FPGA first sends eight dummy or *don't care* bits, followed by a four-bit command. The most commonly used command with the board is COMMAND[3:0] = 0011 binary, which immediately updates the selected DAC output with the specified data value. Following the command, the FPGA selects one or all the DAC output channels via a four-bit address field. Following the address field, the FPGA sends a 12-bit unsigned data value that the DAC converts to an analog value on the selected output(s). Finally, four additional dummy or *don't care* bits pad the 32-bit command word.

Specifying the DAC Output Voltage

As shown in Figure 10-2, each DAC output level is the analog equivalent of a 12-bit unsigned digital value, D[11:0], written by the FPGA to the DAC via the SPI interface.

The voltage on a specific output is generally described in Equation 10-1. The reference voltage, $V_{REFERENCE}$, is different between the four DAC outputs. Channels A and B use a 3.3V reference voltage. Channels C and D have a separate reference voltage, nominally also 3.3V, supplied by the LP3906 regulator designated as IC18. The reference voltage for Channels C and D can be modified, as described in "I2C Voltage Adjustment Interface," page 138.

The reference voltages themselves have a $\pm 5\%$ tolerance, so there are slight corresponding variances in the output voltage.

$$V_{OUT} = \frac{D[11:0]}{4096} \times V_{REFERENCE} \quad \text{Equation 10-1}$$

UCF Location Constraints

Figure 10-5 provides the UCF constraints for the DAC interface, including the I/O pin assignment and the I/O standard used.

```
NET "SPI_MOSI" LOC = "AB14" | IOSTANDARD = LVCMOS33 | SLEW = SLOW | DRIVE = 8 ;
NET "SPI_SCK"  LOC = "AA20" | IOSTANDARD = LVCMOS33 | SLEW = SLOW | DRIVE = 8 ;
NET "DAC_CS"   LOC = "W7"   | IOSTANDARD = LVCMOS33 | SLEW = SLOW | DRIVE = 8 ;
NET "DAC_CLR"  LOC = "AB13" | IOSTANDARD = LVCMOS33 | SLEW = SLOW | DRIVE = 8 ;
NET "DAC_OUT"  LOC = "V7"   | IOSTANDARD = LVCMOS33 ;
```

Figure 10-5: UCF Location Constraints for the DAC Interface

Related Resources

Refer to the following links for additional information:

- **LTC2624 Quad DAC Data Sheet**
<http://www.linear.com/pc/downloadDocument.do?navId=H0,C1,C1155,C1005,C1156,P2048,D2170>
- **Xilinx PicoBlaze Soft Processor**
<http://www.xilinx.com/picoblaze>
- **Digilent, Inc. Peripheral Modules**
<http://www.digilentinc.com/Products/Catalog.cfm?Nav1=Products&Nav2=Peripheral&Cat=Peripheral>

Parallel NOR Flash PROM

As shown in [Figure 11-1](#), the Spartan[®]-3A/3AN FPGA Starter Kit board includes a 32 Mbit (4 Mbyte) parallel NOR Flash PROM.

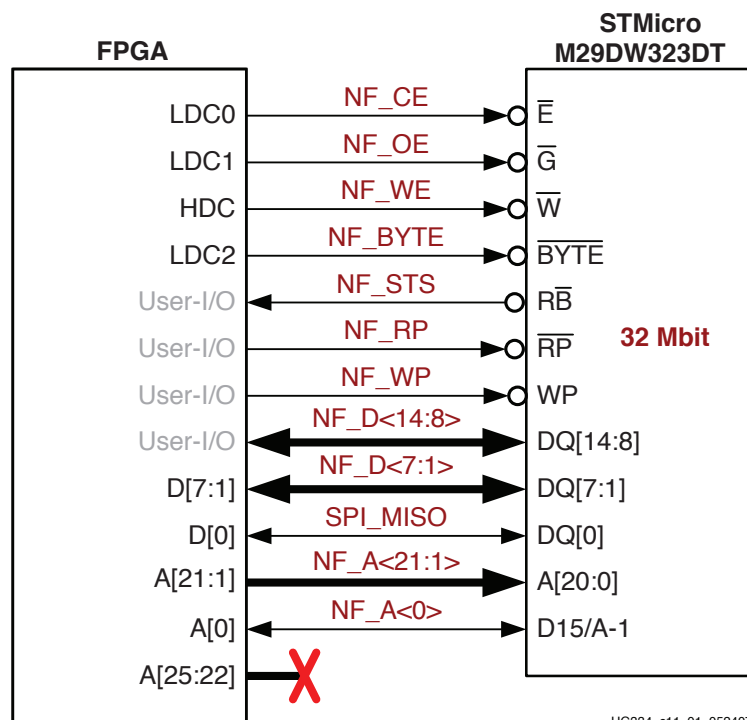

Figure 11-1: Connections to 32 Mbit Parallel NOR Flash Memory

The parallel NOR Flash PROM provides various functions:

- Stores a single FPGA configuration in the Flash memory.
- Stores various, different FPGA configurations in the Flash memory and dynamically switches between the various images using the FPGA's MultiBoot feature.
- Stores and executes MicroBlaze processor code directly from the Flash memory.
- Stores MicroBlaze processor code in the Flash memory and shadows the code into the DDR2 SDRAM memory before executing the code.
- Stores non-volatile user data from the FPGA application.

Flash Connections

Table 11-1 shows the connections between the FPGA and the Flash memory device.

Although the XC3S700A/AN FPGA only requires just slightly over 2.6 Mbits per uncompressed configuration image, the FPGA-to-Flash interface on the board supports up to a 256 Mbit Flash. The Spartan-3A/3AN Starter Kit board ships with a 32 Mbit device. Address lines SF_A<25:22> are not used.

In general, the Flash memory device connects to the FPGA to support Byte Peripheral Interface (BPI) configuration, as described in Table 11-1.

Table 11-1: **FPGA-to-Flash Connections**

Category	NOR Flash Signal Name	FPGA Pin Number	Function
Address	NF_A25	G17	The upper four Flash addresses are not used on the board. The board only has a 32 Mbit parallel NOR Flash PROM.
	NF_A24	G18	
	NF_A23	B21	
	NF_A22	B22	
	NF_A21	C21	Connects to FPGA pins A[21:0] to support the BPI configuration.
	NF_A20	C22	
	NF_A19	F21	
	NF_A18	F22	
	NF_A17	H20	
	NF_A16	H21	
	NF_A15	G22	
	NF_A14	H22	
	NF_A13	J20	
	NF_A12	J21	
	NF_A11	J22	
	NF_A10	K22	
	NF_A9	N17	
	NF_A8	N18	
	NF_A7	N19	
	NF_A6	N20	
	NF_A5	N21	
	NF_A4	N22	
	NF_A3	P18	
	NF_A2	R19	
	NF_A1	T18	
NF_A0	T17		

Table 11-1: FPGA-to-Flash Connections (Continued)

Category	NOR Flash Signal Name	FPGA Pin Number	Function
Data	NF_D15 (NF_A0)	T17	Upper 8 bits of a 16-bit halfword when Flash is configured for x16 data (NF_BYTE=High). The Flash does not have a dedicated D15 pin. Instead, this function is shared with the least-significant address pin. On the Flash memory component, this pin is named D15/A-1, which connects to the FPGA's A0 address pin. After configuration, if the FPGA application asserts NF_BYTE-High, use NF_A0 to carry the D15 signal. Connect the other higher-order data lines to FPGA user I/Os.
	NF_D14	R21	
	NF_D13	T22	
	NF_D12	U22	
	NF_D11	U21	
	NF_D10	V22	
	NF_D9	W22	
	NF_D8	T20	
	NF_D7	Y9	Upper 7 bits of a data byte or lower 8 bits of a 16-bit halfword. Connects to FPGA pins D[7:1] to support the BPI configuration.
	NF_D6	AB9	
	NF_D5	Y11	
	NF_D4	AB11	
	NF_D3	U13	
	NF_D2	AA17	
	NF_D1	Y17	
NF_D0 (SPL_MISO)	AB20	Bit 0 of a data byte and a 16-bit halfword. Connects to FPGA pin D0/DIN to support the BPI configuration. Shared with other SPI peripherals and Platform Flash PROM.	

Table 11-1: FPGA-to-Flash Connections (Continued)

Category	NOR Flash Signal Name	FPGA Pin Number	Function
Control	NF_BYTE	Y21	Active-Low Flash Byte Enable. Connects to FPGA pin LDC2 to support the BPI configuration. 0: x8 data 1: x16 data
	NF_CE	W20	Active-Low Flash Chip Enable. Connects to FPGA pin LDC0 to support the BPI configuration. 0: Enabled 1: Disabled
	NF_OE	W19	Active-Low Flash Chip Enable. Connects to FPGA pin LDC1 to support the BPI configuration. 0: Enable data outputs to read Flash data 1: Disabled
	NF_RP	R22	Active-Low Flash Reset. Connects to FPGA user-I/O pin. 0: Reset 1: Flash active
	NF_STS	P22	Flash Status signal. Optional input to FPGA open-drain output from Flash.
	NF_WE	AA22	Active-Low Flash Write Enable. Connects to FPGA pin HDC to support the BPI configuration. 0: Enable Flash data write operations 1: Disabled
	NF_WP	E14	Active-Low Hardware Write Protect. Connects to FPGA user-I/O pin. 0: Protect two outermost Flash boot blocks against all program and erase operations. 1: Hardware protection disabled.

Shared SPI Flash and Platform Flash Data Line

The least-significant Flash data line, NF_D<0>, is shared with data output signals from the serial SPI serial Flash PROMs and the serial output from the Platform Flash PROM as shown in [Table 11-2, page 87](#). To avoid contention, the FPGA application must ensure that only one data source is active at any time.

Table 11-2: Possible Potential Competing Devices on SPI_MISO (NF_D<0>) Data

Signal or Jumper	Disabled Device	Disable Value
Jumper J46 FPGA_INIT_B	Platform Flash PROM.	Set to "Disabled" or "Enable during Configuration" as shown in Table 4-2, page 40. FPGA_INIT_B has no effect. If set to "Always Enabled," then FPGA_INIT_B must be 1
SPI_SS_B	SPI Flash PROM selected by Jumper J1, as shown in Table 12-2, page 93.	1
ALT_SS_B	SPI Flash PROM selected by Jumper J1, as shown in Table 12-2, page 93.	1

UCF Location Constraints

Address

Figure 11-2 provides the UCF constraints for the Flash address pins, including the I/O pin assignment and the I/O standard used.

```

NET "NF_A<24>" LOC = "A11" | IOSTANDARD = LVCMOS33 | DRIVE = 8 | SLEW = SLOW ;
NET "NF_A<23>" LOC = "N11" | IOSTANDARD = LVCMOS33 | DRIVE = 8 | SLEW = SLOW ;
NET "NF_A<22>" LOC = "V12" | IOSTANDARD = LVCMOS33 | DRIVE = 8 | SLEW = SLOW ;
NET "NF_A<21>" LOC = "C21" | IOSTANDARD = LVCMOS33 | DRIVE = 8 | SLEW = SLOW ;
NET "NF_A<20>" LOC = "C22" | IOSTANDARD = LVCMOS33 | DRIVE = 8 | SLEW = SLOW ;
NET "NF_A<19>" LOC = "F21" | IOSTANDARD = LVCMOS33 | DRIVE = 8 | SLEW = SLOW ;
NET "NF_A<18>" LOC = "F22" | IOSTANDARD = LVCMOS33 | DRIVE = 8 | SLEW = SLOW ;
NET "NF_A<17>" LOC = "H20" | IOSTANDARD = LVCMOS33 | DRIVE = 8 | SLEW = SLOW ;
NET "NF_A<16>" LOC = "H21" | IOSTANDARD = LVCMOS33 | DRIVE = 8 | SLEW = SLOW ;
NET "NF_A<15>" LOC = "G22" | IOSTANDARD = LVCMOS33 | DRIVE = 8 | SLEW = SLOW ;
NET "NF_A<14>" LOC = "H22" | IOSTANDARD = LVCMOS33 | DRIVE = 8 | SLEW = SLOW ;
NET "NF_A<13>" LOC = "J20" | IOSTANDARD = LVCMOS33 | DRIVE = 8 | SLEW = SLOW ;
NET "NF_A<12>" LOC = "J21" | IOSTANDARD = LVCMOS33 | DRIVE = 8 | SLEW = SLOW ;
NET "NF_A<11>" LOC = "J22" | IOSTANDARD = LVCMOS33 | DRIVE = 8 | SLEW = SLOW ;
NET "NF_A<10>" LOC = "K22" | IOSTANDARD = LVCMOS33 | DRIVE = 8 | SLEW = SLOW ;
NET "NF_A<9>" LOC = "N17" | IOSTANDARD = LVCMOS33 | DRIVE = 8 | SLEW = SLOW ;
NET "NF_A<8>" LOC = "N18" | IOSTANDARD = LVCMOS33 | DRIVE = 8 | SLEW = SLOW ;
NET "NF_A<7>" LOC = "N19" | IOSTANDARD = LVCMOS33 | DRIVE = 8 | SLEW = SLOW ;
NET "NF_A<6>" LOC = "N20" | IOSTANDARD = LVCMOS33 | DRIVE = 8 | SLEW = SLOW ;
NET "NF_A<5>" LOC = "N21" | IOSTANDARD = LVCMOS33 | DRIVE = 8 | SLEW = SLOW ;
NET "NF_A<4>" LOC = "N22" | IOSTANDARD = LVCMOS33 | DRIVE = 8 | SLEW = SLOW ;
NET "NF_A<3>" LOC = "P18" | IOSTANDARD = LVCMOS33 | DRIVE = 8 | SLEW = SLOW ;
NET "NF_A<2>" LOC = "R19" | IOSTANDARD = LVCMOS33 | DRIVE = 8 | SLEW = SLOW ;
NET "NF_A<1>" LOC = "T18" | IOSTANDARD = LVCMOS33 | DRIVE = 8 | SLEW = SLOW ;
NET "NF_A<0>" LOC = "T17" | IOSTANDARD = LVCMOS33 | DRIVE = 8 | SLEW = SLOW ;
# Upper four address lines, NF_A<25:22>, are unconnected using a 32Mbit Flash
# They are available as user I/Os but do not connect to anything on the board
CONFIG PROHIBIT = B22;
CONFIG PROHIBIT = B21;
CONFIG PROHIBIT = G18;
CONFIG PROHIBIT = G17;

```

Figure 11-2: UCF Location Constraints for Flash Address Signals

Data

Figure 11-3 provides the UCF constraints for the Flash data pins, including the I/O pin assignment and the I/O standard used.

```
# NET "NF_D<15>" --> use NF_A<0> on pin T17 when NF_BYTE = High
NET "NF_D<14>" LOC = "R21" | IOSTANDARD = LVCMOS33 | DRIVE = 8 | SLEW = SLOW ;
NET "NF_D<13>" LOC = "T22" | IOSTANDARD = LVCMOS33 | DRIVE = 8 | SLEW = SLOW ;
NET "NF_D<12>" LOC = "U22" | IOSTANDARD = LVCMOS33 | DRIVE = 8 | SLEW = SLOW ;
NET "NF_D<11>" LOC = "U21" | IOSTANDARD = LVCMOS33 | DRIVE = 8 | SLEW = SLOW ;
NET "NF_D<10>" LOC = "V22" | IOSTANDARD = LVCMOS33 | DRIVE = 8 | SLEW = SLOW ;
NET "NF_D<9>" LOC = "W22" | IOSTANDARD = LVCMOS33 | DRIVE = 8 | SLEW = SLOW ;
NET "NF_D<8>" LOC = "T20" | IOSTANDARD = LVCMOS33 | DRIVE = 8 | SLEW = SLOW ;
NET "NF_D<7>" LOC = "Y9" | IOSTANDARD = LVCMOS33 | DRIVE = 8 | SLEW = SLOW ;
NET "NF_D<6>" LOC = "AB9" | IOSTANDARD = LVCMOS33 | DRIVE = 8 | SLEW = SLOW ;
NET "NF_D<5>" LOC = "Y11" | IOSTANDARD = LVCMOS33 | DRIVE = 8 | SLEW = SLOW ;
NET "NF_D<4>" LOC = "AB11" | IOSTANDARD = LVCMOS33 | DRIVE = 8 | SLEW = SLOW ;
NET "NF_D<3>" LOC = "U13" | IOSTANDARD = LVCMOS33 | DRIVE = 8 | SLEW = SLOW ;
NET "NF_D<2>" LOC = "AA17" | IOSTANDARD = LVCMOS33 | DRIVE = 8 | SLEW = SLOW ;
NET "NF_D<1>" LOC = "Y17" | IOSTANDARD = LVCMOS33 | DRIVE = 8 | SLEW = SLOW ;
NET "SPI_MISO" LOC = "AB20" | IOSTANDARD = LVCMOS33 | DRIVE = 8 | SLEW = SLOW ;
```

Figure 11-3: UCF Location Constraints for Flash Data I/O Pins

Control

Figure 11-4 provides the UCF constraints for the Flash control pins, including the I/O pin assignment and the I/O standard used.

```
NET "NF_BYTE" LOC = "Y21" | IOSTANDARD = LVCMOS33 | DRIVE = 8 | SLEW = SLOW ;
NET "NF_CE" LOC = "W20" | IOSTANDARD = LVCMOS33 | DRIVE = 8 | SLEW = SLOW ;
NET "NF_OE" LOC = "W19" | IOSTANDARD = LVCMOS33 | DRIVE = 8 | SLEW = SLOW ;
NET "NF_RP" LOC = "R22" | IOSTANDARD = LVCMOS33 | DRIVE = 8 | SLEW = SLOW ;
NET "NF_STB" LOC = "P22" | IOSTANDARD = LVCMOS33 ;
NET "NF_WE" LOC = "AA22" | IOSTANDARD = LVCMOS33 | DRIVE = 8 | SLEW = SLOW ;
NET "NF_WP" LOC = "E14" | IOSTANDARD = LVCMOS33 | DRIVE = 8 | SLEW = SLOW ;
```

Figure 11-4: UCF Location Constraints for Flash Control Pins

Setting the FPGA Mode Select Pins

To configure the FPGA from NOR Flash, set the FPGA configuration mode pins for BPI Up mode, as shown in Table 11-3. The Spartan-3A/3AN FPGA families do not support the BPI Down mode that is available in the Spartan-3E FPGA family.

Also be sure to disable the Platform Flash PROM by removing jumper J46, as shown in Table 11-3.

Table 11-3: Selecting BPI-Up Configuration Mode (J26)

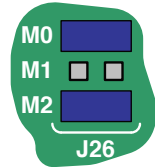
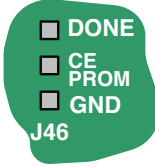
Configuration Mode	Mode Pins M2:M1:M0	FPGA Configuration Image in Flash	Mode Select Jumper Settings (J26)	Platform Flash Enable (J46)
BPI Up	0:1:0	FPGA starts at address 0 and increments through address space.		

Creating and Programming Configuration Images for Parallel Flash

Due to the high fanout of the CCLK signal on the Starter Kit board, it is recommended that the FPGA CCLK frequency be set to 1 MHz when creating FPGA configuration images for the parallel Flash. See UG332 for information on typical configuration clock speeds supported for custom boards.

Refer to the “*Master BPI Mode*” chapter in the *Spartan-3 Generation Configuration User Guide* for information on how to create and format FPGA configuration images for parallel Flash.

To program the parallel Flash memory, see the associated design example.

- **UG332: Spartan-3 Generation Configuration User Guide**
www.xilinx.com/support/documentation/user_guides/ug332.pdf
- **Design Example: Programmer for the STMicroelectronics M29DW323DT Parallel NOR Flash**
www.xilinx.com/products/boards/s3astarter/reference_designs.htm#parallel_flash_programmer

Related Resources

Refer to the following links for additional information:

- **STMicroelectronics M29DW323DT 32 Mbit Parallel NOR Flash PROM**
www.numonyx.com/Documents/Datasheets/M29DW323D.pdf
- **Design Example: Programmer for the STMicroelectronics M29DW323DT Parallel NOR Flash**
www.xilinx.com/products/boards/s3astarter/reference_designs.htm#parallel_flash_programmer

SPI Serial Flash

The Spartan[®]-3A/3AN FPGA Starter Kit board includes two different styles of SPI serial Flash, as shown in [Figure 12-1](#). Only one style is available to configure the FPGA. After configuration, however, the FPGA application has full access to both PROMs for data storage or Flash update purposes.

- STMicroelectronics [M25P16](#) 16 Mbit SPI serial Flash PROM
- Atmel [AT45DB161D](#) 16 Mbit SPI serial DataFlash PROM

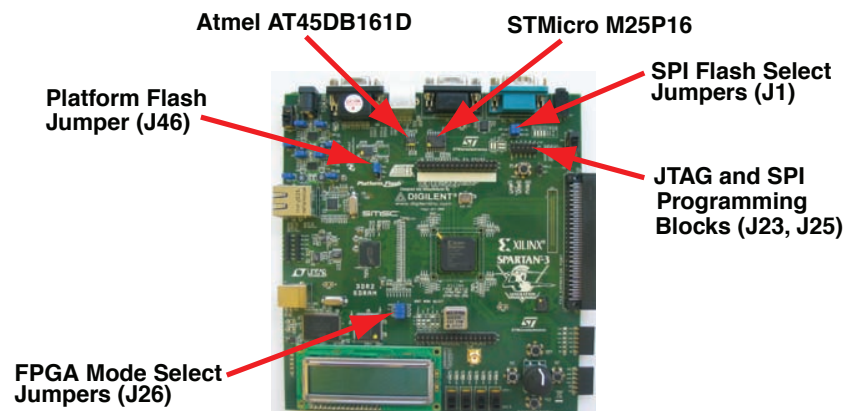

UG334_c12_01_052407

Figure 12-1: SPI Serial Flash PROMs and Associated Jumpers

The SPI serial Flash is useful in a variety of applications. The SPI Flash provides a possible means to configure the FPGA—a new feature in Spartan-3E and Spartan-3A/3AN FPGAs. The SPI Flash is also available to the FPGA after configuration for a variety of purposes, such as:

- Simple non-volatile data storage
- Storage for identifier codes, serial numbers, IP addresses, etc.
- Storage of MicroBlaze processor code that can be shadowed into DDR SDRAM.

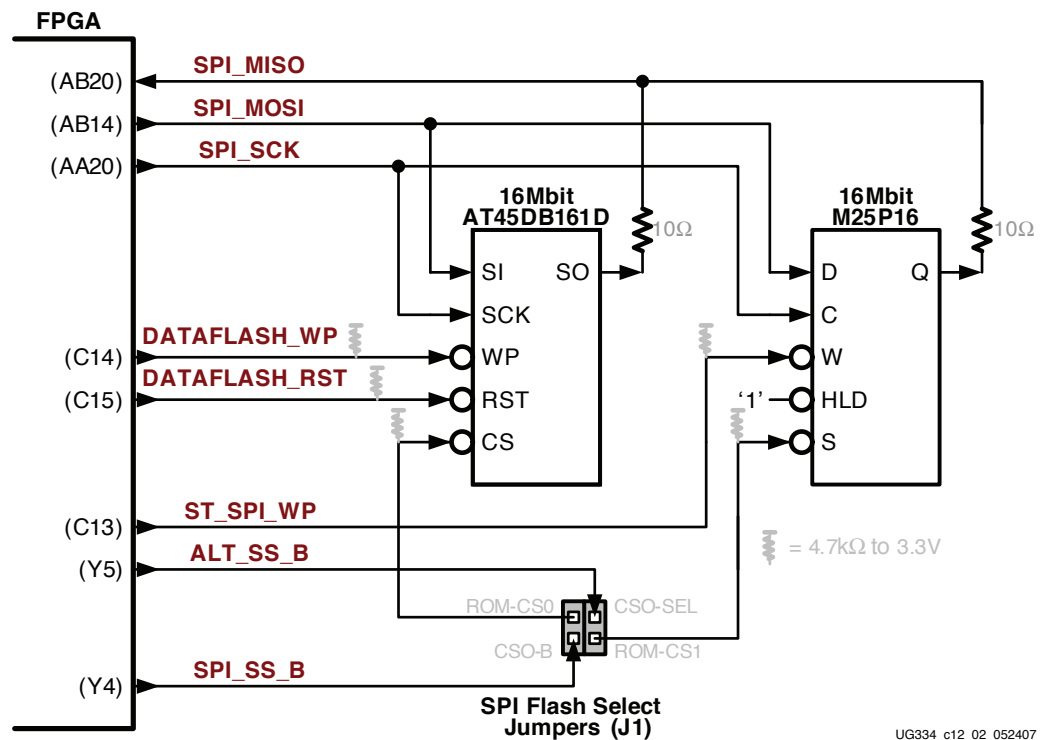

UG334_c12_02_052407

Figure 12-2: SPI Serial Flash Interface

Table 12-1: SPI Flash PROM Interface Signals

Signal	FPGA Pin	Direction	Description
SPI_MISO	AB20	FPGA←PROM	Serial data: Master Input, Slave Output
SPI_MOSI	AB14	FPGA→PROM	Serial data: Master Output, Slave Input
SPI_SCK	AA20	FPGA→PROM	Clock. Actively toggles during configuration. User I/O pin after configuration.
SPI_SS_B	Y4	FPGA→PROM	Asynchronous, active-Low slave select signal. Actively drives Low during SPI Flash configuration mode. User I/O pin after configuration. Drive High if unused. Steered to selected "SPI Flash PROM Select Jumpers (J1)," page 93.
ALT_SS_B	Y5	FPGA→PROM	Second, asynchronous, active-Low slave select signal. Pulled High during configuration. User I/O pin after configuration. Drive High if unused. Steered to selected "SPI Flash PROM Select Jumpers (J1)," page 93.
DATAFLASH_WP	C14	FPGA→PROM	Write-protect input to Atmel AT45DB161D PROM. Must be High to program the PROM. Has external 4.7kΩ pull-up resistor.
DATAFLASH_RST	C15	FPGA→PROM	Reset input to Atmel AT45DB161D PROM. Must be High to read, program, or erase the PROM. Has external 4.7kΩ pull-up resistor.
ST_SPI_WP	C13	FPGA→PROM	Write-protect input to ST M25P16 PROM. Must be High to program the PROM. Has external 4.7kΩ pull-up resistor.

SPI Flash PROM Select Jumpers (J1)

The J1 jumper block, shown in [Figure 12-1](#), defines which SPI Flash PROM is connected to the FPGA for Master SPI mode configuration and which is optionally available via a separate, second SPI slave select signal.

[Table 12-2](#) indicates how the FPGA's CSO_B signal is steered to one of the SPI Flash PROMs during Master SPI configuration mode. The jumpers are designed so that there can be no conflict.

- If both jumpers are inserted and oriented vertically, then the FPGA configures from the Atmel SPI Flash PROM. After configuration, the FPGA application selects the Atmel PROM using the SPI_SS_B signal and the STMicro PROM using the ALT_SS_B signal.
- If both jumpers are inserted and oriented horizontally, then the FPGA configures from the STMicro SPI Flash PROM. After configuration, the FPGA application selects the STMicro PROM using SPI_SS_B signal and the Atmel PROM using the ALT_SS_B signal.

Table 12-2: SPI Flash PROM Select Jumper Settings

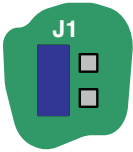
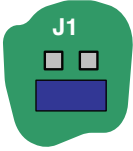
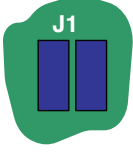
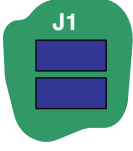
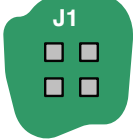
Jumper J1 Setting	SPI Mode Configuration Source	After Configuration	
		Atmel AT45DB161D Slave Select Signal	STMicro M25P16 Slave Select Signal
	Atmel AT45DB161D	SPI_SS_B (Y4)	N/A
	STMicro M25P16	N/A	SPI_SS_B (Y4)
	Atmel AT45DB161D	SPI_SS_B (Y4)	ALT_SS_B (Y5)
	STMicro M25P16	ALT_SS_B (Y5)	SPI_SS_B (Y4)
	None	None	None

Shared SPI Flash and Platform Flash Data Line

The SPI_MISO signal from the two SPI Flash PROMs is shared with data output signals from the parallel NOR Flash PROM and the serial output from the Platform Flash PROM as shown in [Table 12-3](#). To avoid contention, the FPGA application must ensure that only one data source is active at any time.

Table 12-3: Possible Potential Competing Devices on SPI_MISO (NF_D<0>) Data

Signal or Jumper	Disabled Device	Disable Value
Jumper J46 FPGA_INIT_B	Platform Flash PROM.	Set to "Disabled" or "Enable during Configuration" as shown in Table 4-2, page 40 . FPGA_INIT_B has no effect. If set to "Always Enabled," then FPGA_INIT_B must be 1
SPI_SS_B	SPI Flash PROM selected by Jumper J1, as shown in Table 12-2, page 93 .	1
ALT_SS_B	SPI Flash PROM selected by Jumper J1, as shown in Table 12-2, page 93 .	1
NF_CE NF_OE	Parallel Flash PROM	NF_CE = 1 or NF_OE = 1

Jumper Settings to Configure FPGA from Selected SPI Flash PROM

To successfully configure the FPGA from the selected external SPI Flash PROM, set the following jumpers as described below.

- Set the FPGA configure mode, using the Jumper J26 jumper header, shown in [Table 12-4](#).
- Disable the Platform Flash PROM using Jumper J46, shown in [Table 12-4](#).

Table 12-4: Configuration Mode Jumper Settings for Master SPI Mode (J26, J46)

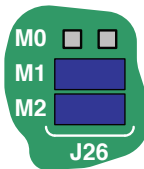
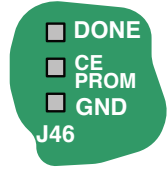
Configuration Mode	Mode Pins M2:M1:M0	Jumper J26 Settings	Platform Flash Enable (J46)
Master SPI	0:0:1		

- Select one of the SPI serial Flash PROMs as the SPI configuration source, as shown in [Table 12-2](#).

UCF Location Constraints

Figure 12-3 provides the UCF constraints for the SPI serial Flash PROM, including the I/O pin assignment and the I/O standard used.

```
# some connections shared with SPI Flash, DAC, ADC, and AMP
NET "SPI_MISO" LOC = "AB20" | IOSTANDARD = LVCMOS33 ;
NET "SPI_MOSI" LOC = "AB14" | IOSTANDARD = LVCMOS33 | SLEW = SLOW | DRIVE = 8 ;
NET "SPI_SCK" LOC = "AA20" | IOSTANDARD = LVCMOS33 | SLEW = SLOW | DRIVE = 8 ;
NET "SPI_SS_B" LOC = "Y4" | IOSTANDARD = LVCMOS33 | SLEW = SLOW | DRIVE = 8 ;
NET "ALT_SS_B" LOC = "Y5" | IOSTANDARD = LVCMOS33 | SLEW = SLOW | DRIVE = 8 ;

# write-protect and reset controls for Atmel AT45DB161D PROM
NET "DATAFLASH_WP" LOC = "C14" | IOSTANDARD = LVCMOS33 | SLEW = SLOW | DRIVE = 8 ;
NET "DATAFLASH_RST" LOC = "C15" | IOSTANDARD = LVCMOS33 | SLEW = SLOW | DRIVE = 8 ;

# write-protect control for ST M25P16 PROM
NET "ST_SPI_WP" LOC = "C13" | IOSTANDARD = LVCMOS33 | SLEW = SLOW | DRIVE = 8 ;
```

Figure 12-3: UCF Location Constraints for SPI Flash Connections

Creating and Programming Configuration Images for SPI Serial Flash

Refer to the “Master SPI Mode” chapter in the *Spartan-3 Generation Configuration User Guide* for information on how to create and format FPGA configuration images for SPI serial Flash and how to program SPI Flash using the Xilinx iMPACT software.

- UG332: Spartan-3 Generation Configuration User Guide
www.xilinx.com/support/documentation/user_guides/ug332.pdf

SPI Flash PROM Programming Options

Starting with ISE® 9.1i, Service Pack 2 and later, the iMPACT programming software supports two different methods to program an attached SPI Flash PROM, as summarized in Table 12-5.

Using the [Direct Programming Method](#), the programming cable communicates directly to the SPI Flash PROM. The FPGA is not involved in the programming process and the FPGA I/O pins that connect to the PROM must be in their high-impedance state (Hi-Z) during programming. Hold the FPGA’s PROG_B input Low using jumper J16 to place the I/Os in Hi-Z; the FPGA’s DONE pin remains Low.

Using the [Indirect Programming Method](#), the programming cable connects to the FPGA’s JTAG port. The iMPACT software first programs the FPGA with a special design that performs the SPI PROM programming and uses the JTAG interface as a serial communications port. During the process, the FPGA’s DONE output is High and the DONE LED is lit because the FPGA is configured with the programming logic. All pins that are not connected to the SPI Flash PROM or the JTAG interface have an internal pull-up resistor to the V_{CCO} voltage supply associated with the pin.

Table 12-5: Summary of SPI Flash PROM Programming Options

	Direct Method	Indirect Method
ISE Version Required	ISE 9.1i or later	ISE 9.1i, Service Pack 2 or later
Interface/Cable Connection	Directly to SPI PROM	FPGA's JTAG Port
DONE Pin Status during Programming	Low	High (FPGA is configured with special programming design)
Required PROG_B Control	PROG_B = Low	N/A
Status of non-SPI Pins during Programming	High-impedance because PROG_B = Low	Pulled High using internal pull-up resistor to associated V _{CCO} supply input

Direct Programming Method

The iMPACT software supports direct programming of select SPI serial Flash. The Spartan-3A/3AN Starter Kit board primarily supports direct programming using the embedded USB JTAG programmer included on the board. Optionally, the SPI Flash can be programmed using a separate programming cable, as well.

Using Embedded USB JTAG Programmer

Follow these steps to prepare the board for direct SPI Flash programming using the embedded USB JTAG programmer included on the board.

1. Disconnect power to the board.
2. Connect either a USB cable between the board and the PC, or connect a separate JTAG cable as described in “Using a Separate JTAG Parallel Programming Cable (Optional),” page 97.
3. Locate the J1, J23, and J25 jumpers in the upper right corner of the board, using Figure 12-1 as a guide. Figure 12-4 also provides a reference diagram.

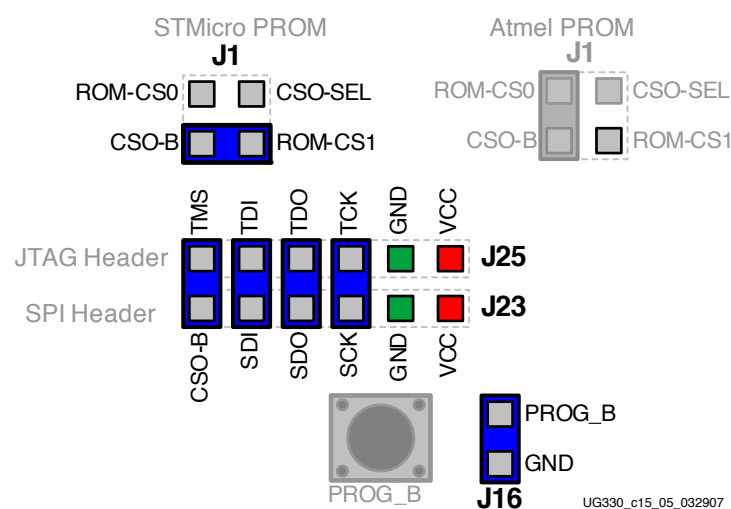

Figure 12-4: Jumper Settings for Direct SPI Flash Programming

4. Insert a jumper in jumper block J1, as shown in [Figure 12-4](#). The figure shows the setting to program the STMicro M25P16 PROM. Alternatively, set the jumper to program the Atmel AT45DB161D DataFlash PROM.
5. Insert four jumpers between jumper blocks J25 and J23, as shown in [Figure 12-4](#). These jumpers connect the embedded USB JTAG programmer on the J25 jumper pins to the SPI PROM via the J23 jumper pins.
6. Set the FPGA mode select pins for Master SPI mode using jumper J26, as shown in [Table 12-4](#). The location of the J26 jumper appears in [Figure 12-1](#).
7. Disable the Platform Flash PROM by removing jumper J46, shown in [Figure 12-1](#) and [Table 12-4](#).
8. For direct programming, the FPGA's PROG_B pin must be held Low. Insert a jumper in jumper J16, as shown in [Figure 12-4](#). This holds all the FPGA's I/O in three-state to allow the JTAG programmer full access to the SPI PROM pins.
9. Re-apply power to the board.

Using a Separate JTAG Parallel Programming Cable (Optional)

[Using Embedded USB JTAG Programmer](#) is the preferred programming method. With the jumpers installed between the J23 and J25 headers, the embedded USB programmer communicates directly to the SPI Flash PROM. However, it is possible to communicate directly to the SPI Flash PROM using another a programming cable, such as:

- [Xilinx Parallel Cable IV](#) with flying leads
- Digilent JTAG3 or [JTAG-USB](#) programming cable

Connect the cable directly to the J23 header block, as illustrated in [Figure 12-5](#). These cables are not provided with the Spartan-3A/3AN Starter Kit board but can be purchased separately.

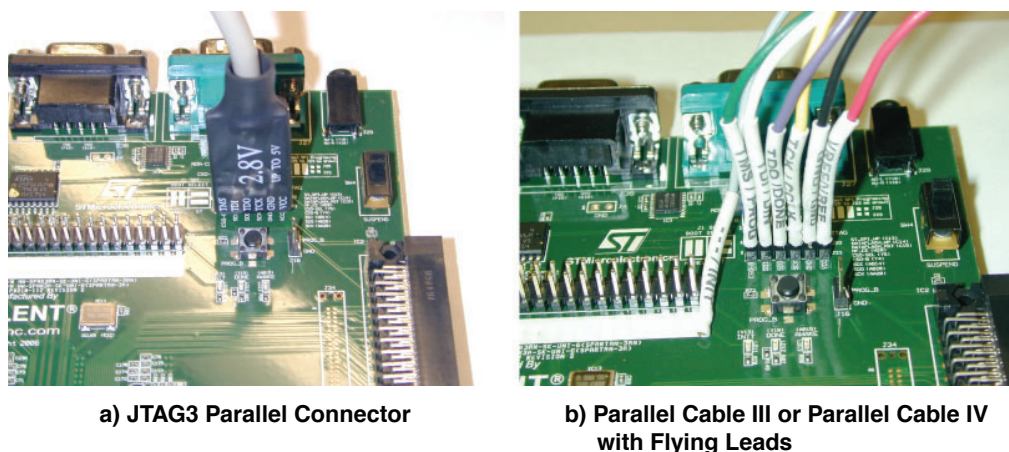

Figure 12-5: Attaching a JTAG Parallel Programming Cable to the Board

First, turn off the power on the Starter Kit board.

If the USB cable is attached to the board, disconnect it. Simultaneously connecting both the USB cable and the parallel cable to the PC confuses the iMPACT software.

Connect one end of the JTAG parallel programming cable to the parallel printer port of the PC.

Connect the JTAG end of the cable to Header J23, as shown in [Figure 12-5a](#). The J23 header connects directly to the SPI Flash pins; it is not connected to the JTAG chain.

The JTAG3 cable directly mounts to Header J23. The labels on the JTAG3 cable face toward the J11 jumpers. If using flying leads, they must be connected as shown in [Figure 12-5b](#) and [Table 12-6](#). Note the color coding for the leads. The gray INIT lead is left unconnected.

Table 12-6: Cable Connections to J23 Header

Cable and Labels	Connections					
J23 Header Label	SEL	SDI	SDO	SCK	GND	VCC
JTAG3 Cable Label	TMS	TDI	TDO	TCK	GND	VCC
Flying Leads Label	TMS/ PROG	TDI/ DIN	TDO/ DONE	TCK/ CCLK	GND/ GND	VREF/ VREF

Direct SPI Flash Programming Using iMPACT

The following steps describe how to program the SPI PROM using the iMPACT software and a Xilinx programming cable.

1. Click **Direct SPI Configuration** from within iMPACT, as shown in [Figure 12-6](#).

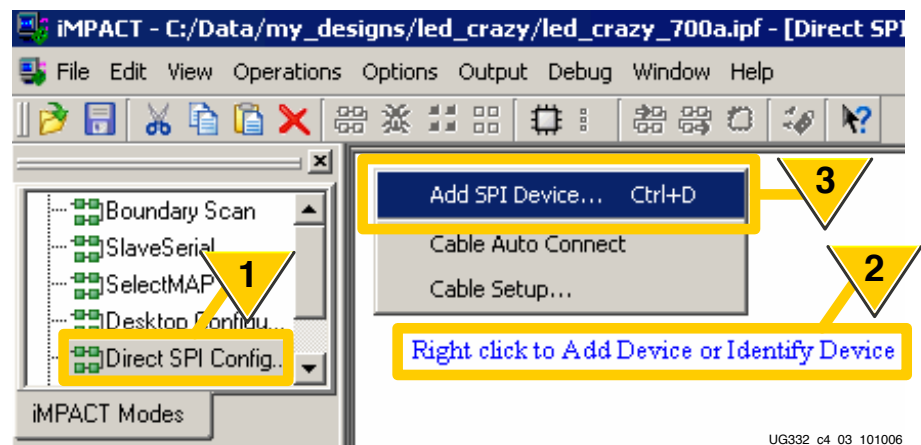

Figure 12-6: iMPACT Supports Direct Programming for SPI Serial Flash Memories

2. Right-click in the area indicated.
3. Select **Add SPI Device**.

4. Select a previously formatted PROM file, as shown in [Figure 12-7](#).

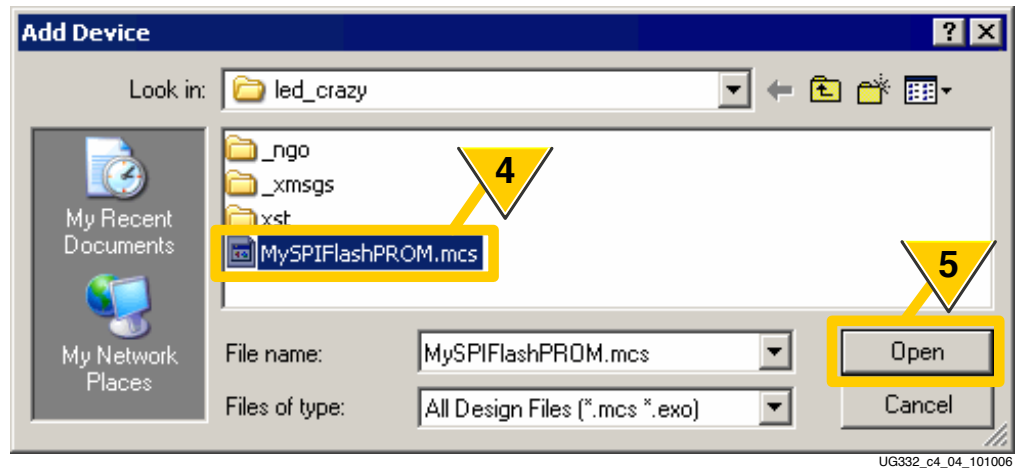

Figure 12-7: Select a Previously Formatted PROM File

5. Click **Open**.
6. Select the **Part Name** for a supported SPI serial Flash, as shown in [Figure 12-8](#).

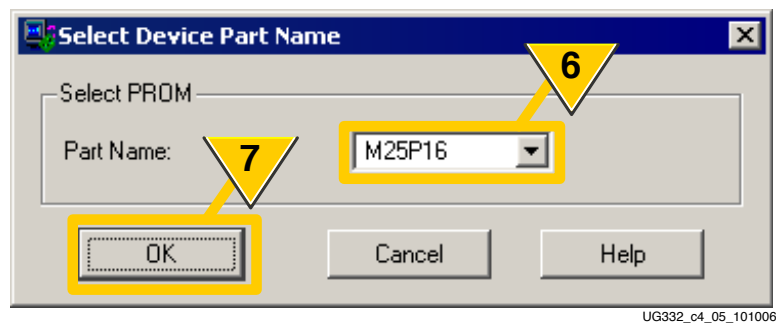

Figure 12-8: Select a Supported SPI Flash Memory Device

7. Click **OK**.

8. The iMPACT software displays the selected SPI Flash PROM, as shown in Figure 12-9.

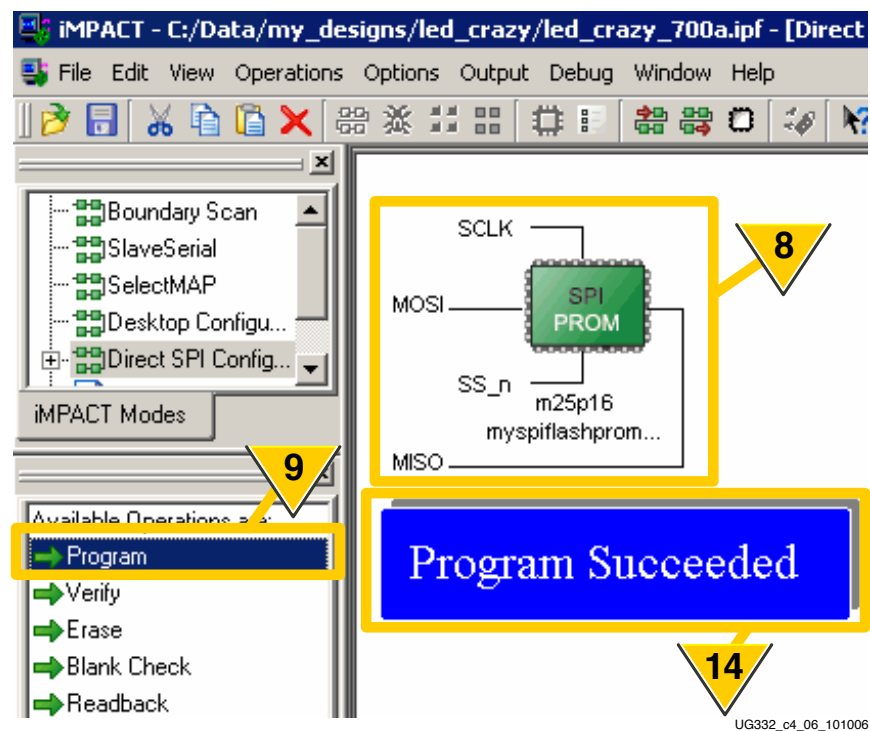

Figure 12-9: Directly Program Supported SPI Flash PROM

9. Click **Program**.

Note: Step 14 occurs later.

10. Click the **Programming Properties** option under **Category**, as shown in Figure 12-10.

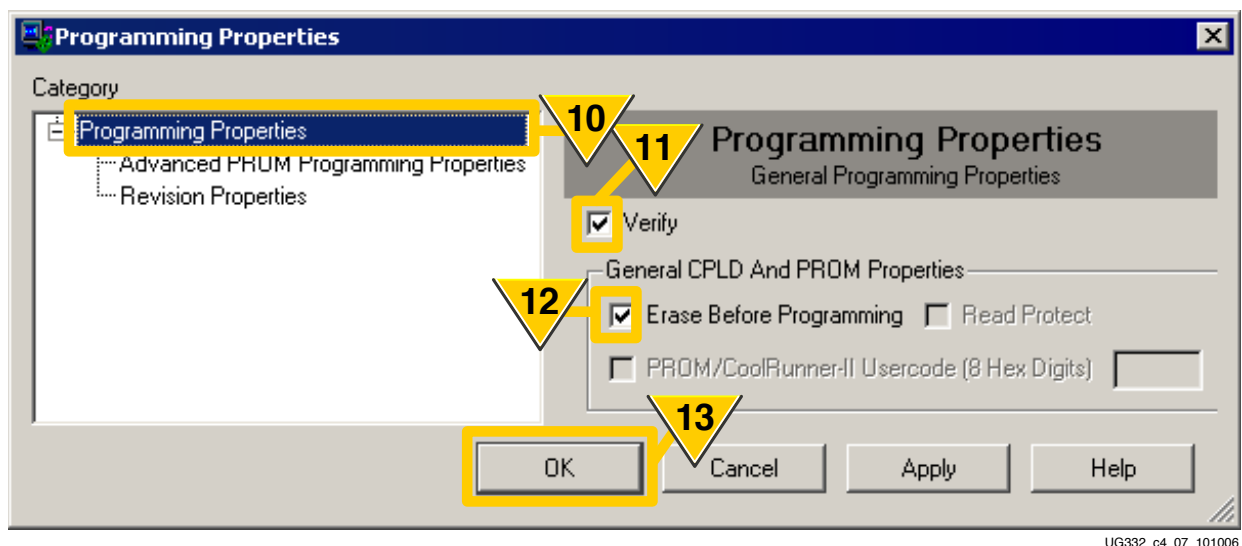

Figure 12-10: SPI PROM Programming Options

11. Check **Verify**. Unchecking Verify reduces programming time but the iMPACT software can only guarantee correct programming for a verified PROM.

12. Check **Erase Before Programming**. Unchecking the Erase option reduces programming time. However, Xilinx recommends erasing the PROM when downloading a new FPGA bitstream.
13. Click **OK**.
14. The iMPACT software indicates successful programming, as shown in [Figure 12-9](#).
After programming completes:
15. Turn off power to the board.
16. Remove Jumper J16 to release the FPGA's PROG_B pin.
17. Remove the four jumpers connecting jumper blocks J23 and J25.
18. Reapply power.

Indirect Programming Method

Indirect programming support is available starting with Xilinx ISE 9.1i, Service Pack 2 and later releases. In Indirect mode, the iMPACT software programs the memory attached to the FPGA through the FPGA's JTAG port.

During the programming process, the FPGA is configured with a special programming application. Consequently, the FPGA's DONE pin is High and the DONE LED remains lit throughout the programming process.

Note: Any information displayed on the LCD screen remains on the screen throughout the programming process.

If it appears that programming was successful but that the DONE pin did not go High at the end, double-check the mode pin settings.

Jumper Settings

To program the attached and selected SPI PROM using the Indirect method, configure the board as described below.

1. Disconnect power to the board.
2. Insert a jumper in jumper block J1, as shown in [Figure 12-4](#). The figure shows the setting to program the STMicro M25P16 PROM. Alternatively, set the jumper to program the Atmel AT45DB161D DataFlash PROM.
3. Set the FPGA mode select pins for Master SPI mode using jumper J26, as shown in [Table 12-4](#). The location of the J26 jumper appears in [Figure 12-1](#).
4. Disable the Platform Flash PROM by removing jumper J46, shown in [Figure 12-1](#) and [Table 12-4](#).
5. The PROG_B pin is not used by the Indirect programming mode. Be sure that jumper J16 is removed (PROG_B is left floating).
6. Connect the included USB cable to both the Starter Kit board and the computer running iMPACT.
7. Re-apply power to the board.

Indirect SPI Flash Programming Using iMPACT

To program the attached and selected SPI PROM using the iMPACT software and the Indirect programming method, follow the steps outlined below.

1. Invoke iMPACT and select **Configure devices using Boundary Scan (JTAG)**, as shown in [Figure 12-11](#).

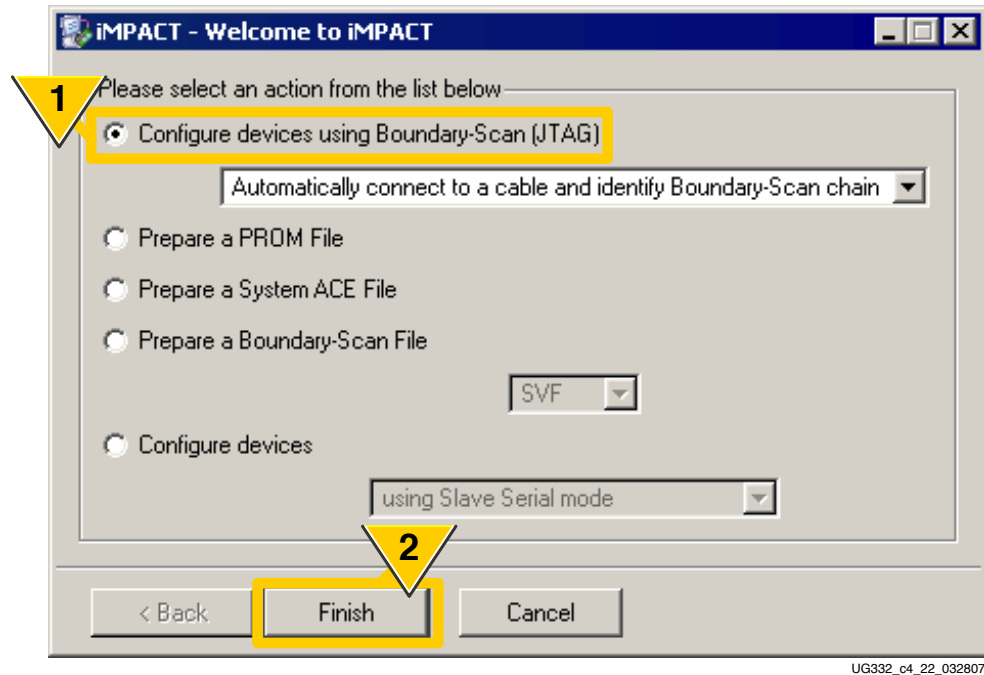

Figure 12-11: Indirect Programming Method Uses JTAG

2. Select **Finish**.

3. Select the FPGA bitstream file (*.bit) to be programmed into the FPGA, as shown in Figure 12-12. This step is superfluous but required for iMPACT 9.1i. This step will be eliminated starting in iMPACT 9.2i. This file is *not* the special FPGA-based SPI programming application.

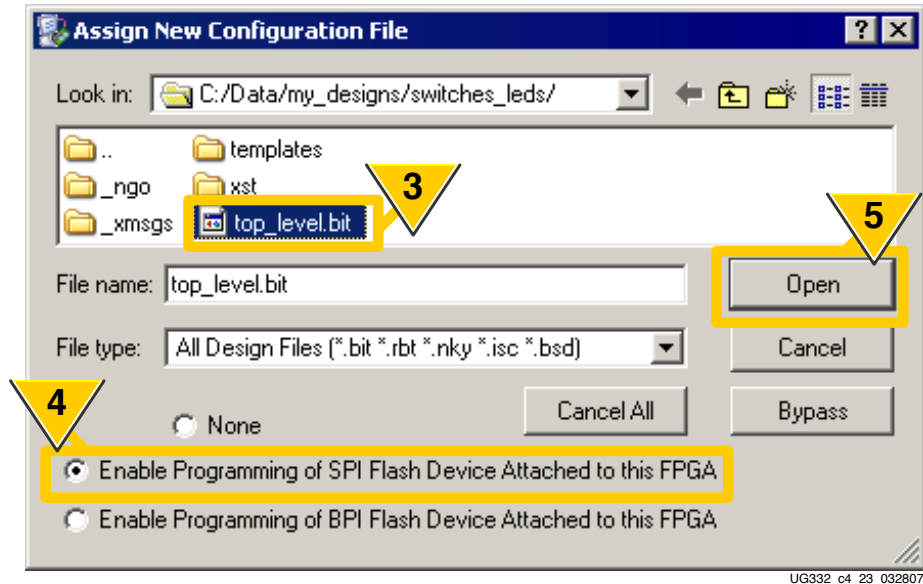

Figure 12-12: Select the FPGA Bitstream File and Enable SPI Programming

4. Select **Enable Programming of SPI Flash Device Attached to this FPGA**.
5. Click **Open**.
6. The iMPACT software warns that it changed the Startup clock source over to the JTAG clock pin, TCK. The SPI Flash image is not affected. This warning is safely ignored.

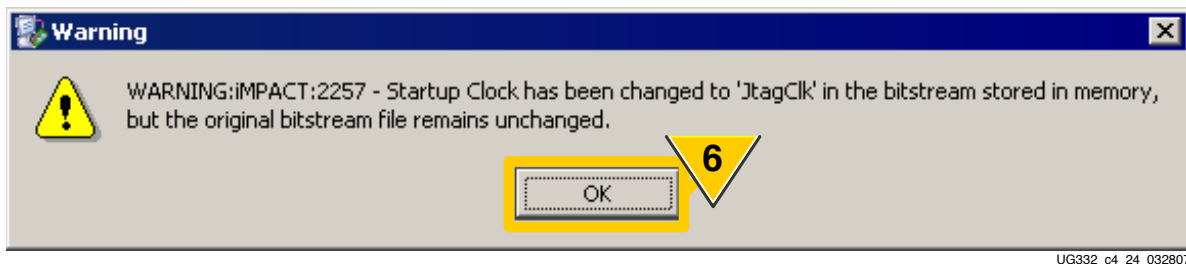

Figure 12-13: iMPACT Uses the JTAG Clock Input TCK for Startup Clock when Programming via JTAG

7. As shown in [Figure 12-14](#), select the programming file for the attached SPI Flash PROM.

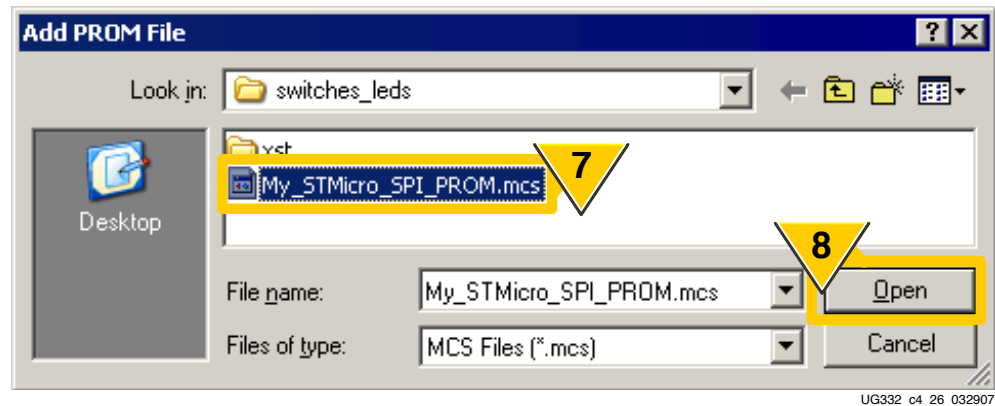

Figure 12-14: Select the SPI PROM Programming File

8. Click **Open**.
9. Select the part number for the attached SPI Flash PROM, as shown in [Figure 12-15](#).

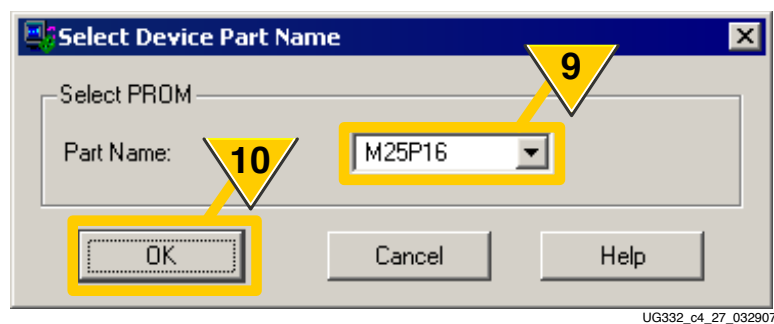
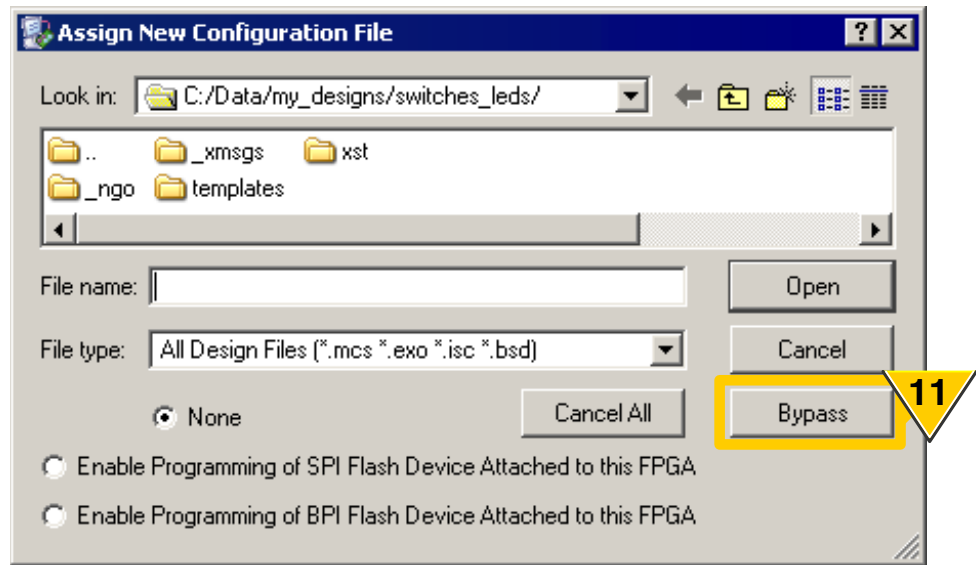

Figure 12-15: Select SPI Flash PROM Type

10. Click **OK**.

11. Select **Bypass** when prompted for the Platform Flash PROM programming file, as shown in Figure 12-16.



UG332_c4_28_032907

Figure 12-16: Bypass the Platform Flash PROM

12. As shown in Figure 12-17, the iMPACT software then displays the JTAG chain for the XC3S700A Spartan-3A FPGA followed by the XCF04S Platform Flash PROM. A similar display will be seen for the XC3S700AN Spartan-3AN FPGA. Click to highlight the **FLASH** memory attached to the XC3S700A FPGA. This action enables the command options shown in Step 13.

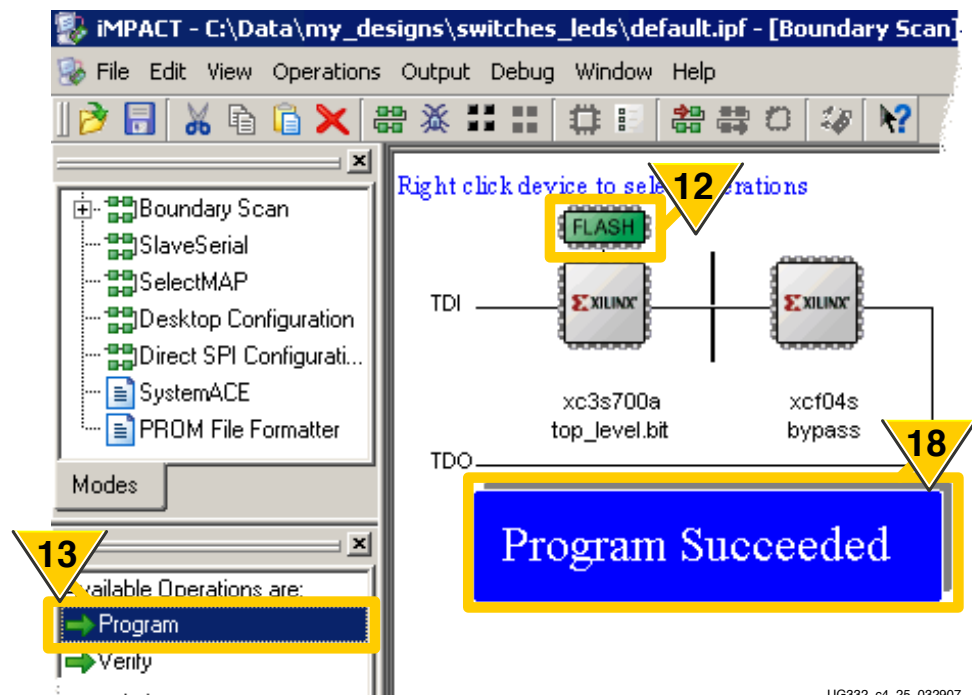

UG332_c4_25_032907

Figure 12-17: iMPACT Presents JTAG Chain, Shows Attached Flash PROM

13. Double-click **Program**.

Note: Step 18 occurs later.

14. Click the **Programming Properties** option under **Category**, as shown in Figure 12-18.

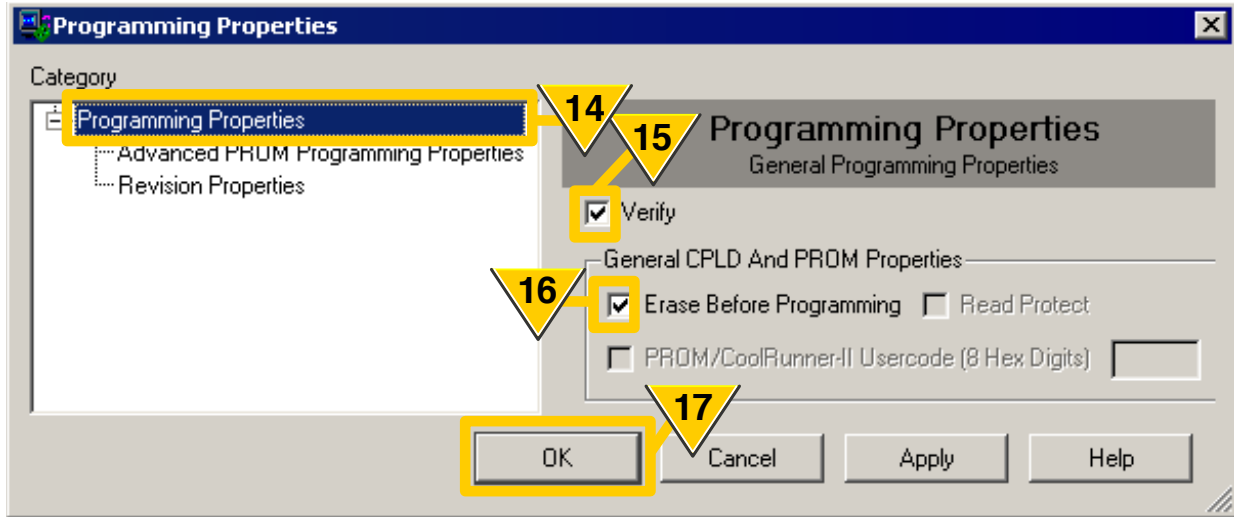

UG332_c4_29_032907

Figure 12-18: SPI PROM Programming Options

15. Check **Verify**. Unchecking Verify reduces programming time but the iMPACT software can only guarantee correct programming for a verified PROM.
16. Check **Erase Before Programming**. Unchecking the Erase option reduces programming time. However, Xilinx recommends erasing the PROM when downloading a new FPGA bitstream.
17. Click **OK**.
18. The iMPACT software indicates successful programming, as shown in Figure 12-18. The FPGA is configured with the new programming file.

Related Resources

Refer to the following links for additional information:

- [Xilinx Parallel Cable IV](http://www.xilinx.com/onlinestore/program_solutions.htm#pc) with Flying Leads
- [Digilent JTAG3 Programming Cable](http://www.digilentinc.com/Products/Catalog.cfm?Nav1=Products&Nav2=Cables&Cat=Cable)
- [Atmel AT45DB161D DataFlash Data Sheet](http://www.atmel.com/dyn/resources/prod_documents/doc3500.pdf)
- [STMicroelectronics M25P16 SPI Serial Flash Data Sheet](http://www.numonyx.com/Documents/Datasheets/M25P16.pdf)
- [Atmel SPI Serial Flash Programmer, via RS-232 \(Reference Design\)](http://www.xilinx.com/products/boards/s3astarter/reference_designs.htm#atmel_spi_flash_programmer)
- [Universal Scan SPI Flash Programming via JTAG Training Video](http://www.ricreations.com/JTAG-Software-Downloads.htm)

DDR2 SDRAM

The Spartan®-3A/3AN FPGA Starter Kit board includes a 512 Mbit (32M x 16) Micron Technology DDR2 SDRAM (MT47H32M16) with a 16-bit data interface, as shown in Figure 13-1.

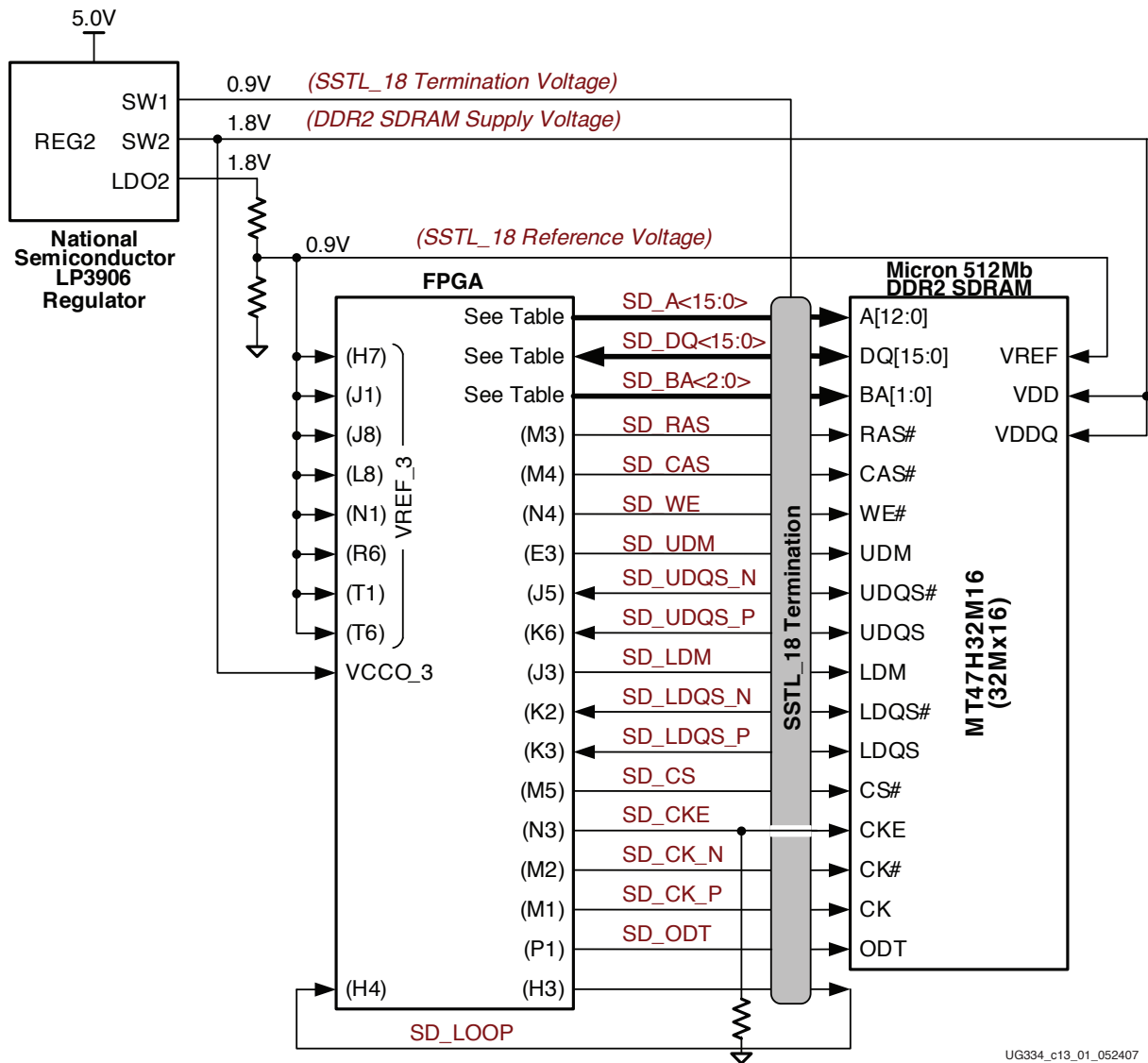

Figure 13-1: FPGA Interface to Micron 512 Mbit DDR2 SDRAM

All DDR2 SDRAM interface pins connect to the FPGA's I/O Bank 3 on the FPGA. I/O Bank 3 and the DDR2 SDRAM are both powered by 1.8V, supplied by a second National Semiconductor LP3906 regulator from the board's 5V supply input. The 0.9V reference voltage, common to the FPGA and DDR2 SDRAM, is also supplied by the National Semiconductor regulator. See "Voltage Regulators" in the [Starter Kit Schematic](#).

All DDR2 SDRAM interface signals are terminated. See "DDR2 SDRAM Termination Network" in the [Starter Kit Schematic](#) for information on the SSTL18 termination scheme used on the board.

DDR2 SDRAM Connections

Table 13-1 shows the connections between the FPGA and the DDR2 SDRAM. Also see "32Mx16 DDR2 SDRAM" in the [Starter Kit Schematic](#).

Table 13-1: FPGA-to-DDR2 SDRAM Connections

Category	DDR2 SDRAM Signal Name	FPGA Pin Number	Function
Address	SD_A15	W3	Unused on 512 Mbit DDR2 SDRAM device but provided for potential future upgrades
	SD_A14	V4	
	SD_A13	V3	
	SD_A12	Y2	Address inputs
	SD_A11	V1	
	SD_A10	T3	
	SD_A9	W2	
	SD_A8	W1	
	SD_A7	Y1	
	SD_A6	U1	
	SD_A5	U4	
	SD_A4	U2	
	SD_A3	U3	
	SD_A2	R1	
	SD_A1	T4	
	SD_A0	R2	

Table 13-1: FPGA-to-DDR2 SDRAM Connections (Continued)

Category	DDR2 SDRAM Signal Name	FPGA Pin Number	Function
Data	SD_DQ15	F3	Data input/output. Outputs defined for compatibility with the Xilinx Memory Interface Generator (MIG) software.
	SD_DQ14	G3	
	SD_DQ13	F1	
	SD_DQ12	H5	
	SD_DQ11	H6	
	SD_DQ10	G1	
	SD_DQ9	G4	
	SD_DQ8	F2	
	SD_DQ7	H2	
	SD_DQ6	K4	
	SD_DQ5	L1	
	SD_DQ4	L5	
	SD_DQ3	L3	
	SD_DQ2	K1	
	SD_DQ1	K5	
SD_DQ0	H1		
Control	SD_BA2	P5	Bank address inputs
	SD_BA1	R3	
	SD_BA0	P3	
	SD_RAS	M3	Command inputs
	SD_CAS	M4	
	SD_WE	N4	
	SD_CK_N	M2	Differential clock input
	SD_CK_P	M1	
	SD_CKE	N3	Active-High clock enable input
	SD_CS	M5	Active-Low chip select input
	SD_UDM	E3	Data Mask. Upper and Lower data masks.
	SD_LDM	J3	
	SD_UDQS_N	J5	Upper differential data strobe
	SD_UDQS_P	K6	
	SD_LDQS_N	K2	Lower differential data strobe
SD_LDQS_P	K3		

Table 13-1: FPGA-to-DDR2 SDRAM Connections (Continued)

Category	DDR2 SDRAM Signal Name	FPGA Pin Number	Function
Miscellaneous	SD_LOOP_IN	H4	I/O self-calibration loop. Direction can be reversed if more convenient in the FPGA application.
	SD_LOOP_OUT	H3	
	SD_ODT	P1	DDR2 SDRAM on-device termination control

UCF Location Constraints

Address

Figure 13-2 provides the User Constraint File (UCF) constraints for the DDR2 SDRAM address pins, including the I/O pin assignment and the I/O standard used.

```

NET "SD_A<15>" LOC = "W3" | IOSTANDARD = SSTL18_II ;
NET "SD_A<14>" LOC = "V4" | IOSTANDARD = SSTL18_II ;
NET "SD_A<13>" LOC = "V3" | IOSTANDARD = SSTL18_II ;
NET "SD_A<12>" LOC = "Y2" | IOSTANDARD = SSTL18_II ;
NET "SD_A<11>" LOC = "V1" | IOSTANDARD = SSTL18_II ;
NET "SD_A<10>" LOC = "T3" | IOSTANDARD = SSTL18_II ;
NET "SD_A<9>" LOC = "W2" | IOSTANDARD = SSTL18_II ;
NET "SD_A<8>" LOC = "W1" | IOSTANDARD = SSTL18_II ;
NET "SD_A<7>" LOC = "Y1" | IOSTANDARD = SSTL18_II ;
NET "SD_A<6>" LOC = "U1" | IOSTANDARD = SSTL18_II ;
NET "SD_A<5>" LOC = "U4" | IOSTANDARD = SSTL18_II ;
NET "SD_A<4>" LOC = "U2" | IOSTANDARD = SSTL18_II ;
NET "SD_A<3>" LOC = "U3" | IOSTANDARD = SSTL18_II ;
NET "SD_A<2>" LOC = "R1" | IOSTANDARD = SSTL18_II ;
NET "SD_A<1>" LOC = "T4" | IOSTANDARD = SSTL18_II ;
NET "SD_A<0>" LOC = "R2" | IOSTANDARD = SSTL18_II ;

```

Figure 13-2: UCF Location Constraints for DDR2 SDRAM Address Inputs

Data

Figure 13-3 provides the User Constraint File (UCF) constraints for the DDR2 SDRAM data pins, including the I/O pin assignment and I/O standard used.

```

NET "SD_DQ<15>" LOC = "F3" | IOSTANDARD = SSTL18_II ;
NET "SD_DQ<14>" LOC = "G3" | IOSTANDARD = SSTL18_II ;
NET "SD_DQ<13>" LOC = "F1" | IOSTANDARD = SSTL18_II ;
NET "SD_DQ<12>" LOC = "H5" | IOSTANDARD = SSTL18_II ;
NET "SD_DQ<11>" LOC = "H6" | IOSTANDARD = SSTL18_II ;
NET "SD_DQ<10>" LOC = "G1" | IOSTANDARD = SSTL18_II ;
NET "SD_DQ<9>" LOC = "G4" | IOSTANDARD = SSTL18_II ;
NET "SD_DQ<8>" LOC = "F2" | IOSTANDARD = SSTL18_II ;
NET "SD_DQ<7>" LOC = "H2" | IOSTANDARD = SSTL18_II ;
NET "SD_DQ<6>" LOC = "K4" | IOSTANDARD = SSTL18_II ;
NET "SD_DQ<5>" LOC = "L1" | IOSTANDARD = SSTL18_II ;
NET "SD_DQ<4>" LOC = "L5" | IOSTANDARD = SSTL18_II ;
NET "SD_DQ<3>" LOC = "L3" | IOSTANDARD = SSTL18_II ;
NET "SD_DQ<2>" LOC = "K1" | IOSTANDARD = SSTL18_II ;
NET "SD_DQ<1>" LOC = "K5" | IOSTANDARD = SSTL18_II ;
NET "SD_DQ<0>" LOC = "H1" | IOSTANDARD = SSTL18_II ;

```

Figure 13-3: UCF Location Constraints for DDR2 SDRAM Data I/O Pins

Control

Figure 13-4 provides the User Constraint File (UCF) constraints for the DDR2 SDRAM control pins, including the I/O pin assignment and the I/O standard used.

```

NET "SD_BA<2>" LOC = "P5" | IOSTANDARD = SSTL18_II ;
NET "SD_BA<1>" LOC = "R3" | IOSTANDARD = SSTL18_II ;
NET "SD_BA<0>" LOC = "P3" | IOSTANDARD = SSTL18_II ;
NET "SD_RAS" LOC = "M3" | IOSTANDARD = SSTL18_II ;
NET "SD_CAS" LOC = "M4" | IOSTANDARD = SSTL18_II ;
NET "SD_WE" LOC = "N4" | IOSTANDARD = SSTL18_II ;
NET "SD_CK_N" LOC = "M2" | IOSTANDARD = SSTL18_II ;
NET "SD_CK_P" LOC = "M1" | IOSTANDARD = SSTL18_II ;
NET "SD_CKE" LOC = "N3" | IOSTANDARD = SSTL18_II ;
NET "SD_CS" LOC = "M5" | IOSTANDARD = SSTL18_II ;
NET "SD_UDM" LOC = "E3" | IOSTANDARD = SSTL18_II ;
NET "SD_UDQS_N" LOC = "J5" | IOSTANDARD = SSTL18_II ;
NET "SD_UDQS_P" LOC = "K6" | IOSTANDARD = SSTL18_II ;
NET "SD_LDM" LOC = "J3" | IOSTANDARD = SSTL18_II ;
NET "SD_LDQS_N" LOC = "K2" | IOSTANDARD = SSTL18_II ;
NET "SD_LDQS_P" LOC = "K3" | IOSTANDARD = SSTL18_II ;
NET "SD_ODT" LOC = "P1" | IOSTANDARD = SSTL18_II ;
NET "SD_LOOP_IN" LOC = "H4" | IOSTANDARD = SSTL18_II ;
NET "SD_LOOP_OUT" LOC = "H3" | IOSTANDARD = SSTL18_II ;

```

Figure 13-4: UCF Location Constraints for DDR2 SDRAM Control Pins

Reserve FPGA V_{REF} Pins

Five pins in I/O Bank 3 are dedicated as voltage reference inputs, V_{REF} . These pins cannot be used for general-purpose I/Os in a design. Prohibit the software from using these pins with the constraints provided in [Figure 13-5](#).

```
# Prohibit VREF pins on FPGA I/O Bank 3
CONFIG PROHIBIT = H7;
CONFIG PROHIBIT = J1;
CONFIG PROHIBIT = J8;
CONFIG PROHIBIT = L8;
CONFIG PROHIBIT = N1;
CONFIG PROHIBIT = R6;
CONFIG PROHIBIT = T1;
CONFIG PROHIBIT = T6;
```

Figure 13-5: UCF Location Constraints for FPGA V_{REF} Pins

Special Layout Recommendations

The Xilinx Memory Interface Generator (MIG) tool, version 1.7 and later, generates DDR2 SDRAM interfaces for Spartan-3A and Spartan-3AN FPGAs. The MIG implementation leverages the FPGA's local clocking resources to capture the DDR2 SDRAM read data. Consequently, there is a close relationship between the memory data pins (SD_DQ<15:8>, SD_DQ_<7:0>) and their associated strobe signals. The MIG software automatically assigns pins based on this requirement and the Spartan-3A/3AN Starter Kit board is designed accordingly.

The MIG core for Spartan-3A/3AN FPGAs includes a loopback signal to calibrate the read strobe timing. The loopback signal uses two FPGA pins, labeled SD_LOOP_IN and SD_LOOP_OUT. For best performance, the length of the loop back trace must be equal to the clock delay from the FPGA to the memory, plus the strobe delay from the memory back to the FPGA. Put another way, the loopback trace must be one round trip time to and from the memory. Also, the loopback signal should be in the center of the data interface pins for best results, not near the edge or in another FPGA I/O bank. The Spartan-3A/3AN Starter Kit board was designed accordingly.

The *Xilinx Memory Interface Generator (MIG) User Guide* provides additional layout recommendations in *Appendix A: "Memory Implementation Guidelines"*.

The board layout has been optimized for reaching frequencies above 133 MHz and 167 MHz. It can actually achieve the DDR400 performance level of 200 MHz or 400 Mbps per I/O, with an optimized memory interface controller. It is recommended to get the latest updates of the MIG tool that integrates the latest performance enhancements.

- **Memory Interface Generator (MIG)**
www.xilinx.com/support/download/index.htm
(now included with the CORE Generator™ system)
- **UG086: Xilinx Memory Interface Generator (MIG) User Guide**
(included with MIG)
- **XAPP458: Implementing DDR2-400 Memory Interfaces in Spartan-3A FPGAs**
www.xilinx.com/support/documentation/application_notes/xapp458.pdf

Related Resources

Refer to the following links for additional information:

- **Xilinx Embedded Development Kit (EDK)**
www.xilinx.com/ise/embedded_design_prod/platform_studio.htm
- **MT47H32M16 (32M x 16) DDR2 SDRAM Data Sheet**
download.micron.com/pdf/datasheets/dram/ddr2/512MbDDR2.pdf
- **Multi-Channel OPB DDR2 Controller Xilinx IP Core**
www.xilinx.com/support/documentation/ip_documentation/mch_opb_ddr2.pdf
- **Memory Interface Generator (MIG), Version 1.7 or later**
www.xilinx.com/memory

10/100 Ethernet Physical Layer Interface

The Spartan[®]-3A/3AN FPGA Starter Kit board includes a Standard Microsystems LAN8700 10/100 Ethernet physical layer (PHY) interface and an RJ-45 connector, as shown in [Figure 14-1](#). With an Ethernet Media Access Controller (MAC) implemented in the FPGA, the board can optionally connect to a standard Ethernet network. All timing is controlled from an on-board 25 MHz crystal oscillator.

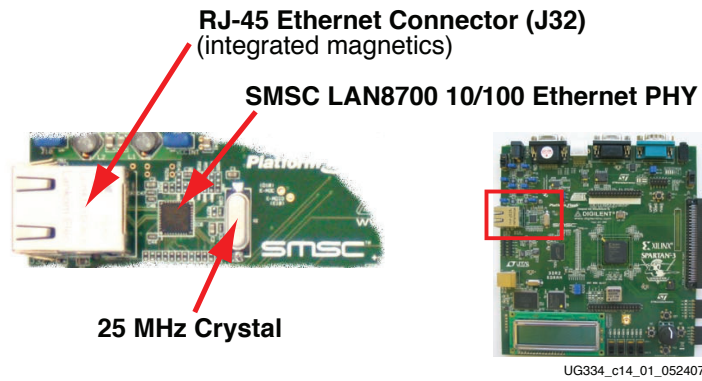
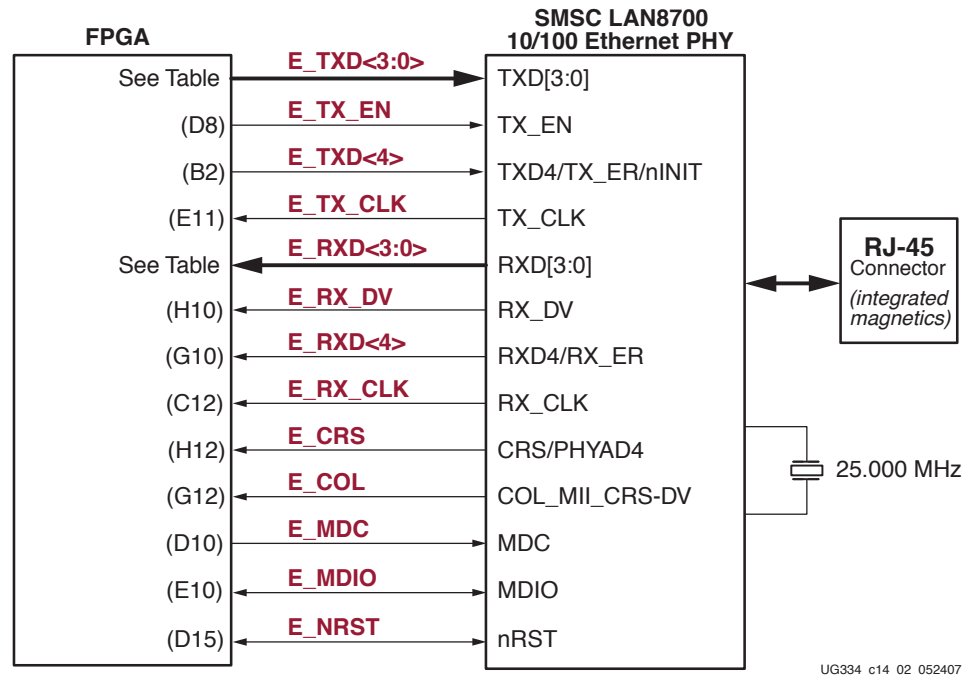

Figure 14-1: 10/100 Ethernet PHY with RJ-45 Connector

Ethernet PHY Connections

The FPGA connects to the LAN8700 Ethernet PHY using a standard Media Independent Interface (MII), as shown in Figure 14-2. A more detailed description of the interface signals, including the FPGA pin number, appears in Table 14-1.



UG334_c14_02_052407

Figure 14-2: FPGA Connects to Ethernet PHY via MII

Table 14-1: FPGA Connections to the LAN83C185 Ethernet PHY

Signal Name	FPGA Pin Number	Function
E_TXD<4>	B2	Transmit Data to the PHY. E_TXD<4> is also the MII Transmit Error.
E_TXD<3>	F7	
E_TXD<2>	E6	
E_TXD<1>	E7	
E_TXD<0>	F8	
E_TX_EN	D8	Transmit Enable
E_TX_CLK	E11	Transmit Clock. 25 MHz in 100Base-TX mode and 2.5 MHz in 10Base-T mode.
E_RXD<4>	G10	Receive Data from the PHY
E_RXD<3>	H9	
E_RXD<2>	G9	
E_RXD<1>	G8	
E_RXD<0>	G7	

Table 14-1: FPGA Connections to the LAN83C185 Ethernet PHY (Continued)

Signal Name	FPGA Pin Number	Function
E_RX_DV	H10	Receive Data Valid
E_RX_CLK	C12	Receive Clock. 25 MHz in 100Base-TX mode and 2.5 MHz in 10Base-T mode.
E_CRS	H12	Carrier Sense
E_COL	G12	MII Collision Detect
E_MDC	D10	Management Clock. Serial management clock.
E_MDIO	E10	Management Data Input/Output
E_NRST	D15	Active-Low Reset

MicroBlaze Ethernet IP Cores

The Ethernet PHY is primarily intended for use with MicroBlaze applications. As such, an Ethernet MAC is part of the EDK Platform Studio's Base System Builder. Both the full Ethernet MAC and the *Lite* version are available for evaluation. The Ethernet Lite MAC controller core uses fewer FPGA resources and is ideal for applications that do not require support for interrupts, back-to-back data transfers, and statistics counters.

The Ethernet MAC core requires design constraints to meet the required performance. Refer to the OPB Ethernet MAC data sheet (v1.02) for details. The OPB clock frequency must be 65 MHz or higher for 100 Mbps Ethernet operations and 6.5 MHz or faster for 10 Mbps Ethernet operations.

The hardware evaluation versions of the Ethernet MAC cores operate for approximately eight hours in silicon before timing out. To order the full version of the core, visit the Xilinx website at:

www.xilinx.com/products/ipcenter/OPB_10_100_Lite.htm

UCF Location Constraints

Figure 14-3 provides the UCF constraints for the 10/100 Ethernet PHY interface, including the I/O pin assignment and the I/O standard used.

```

NET "E_COL"      LOC = "G12" | IOSTANDARD = LVCMOS33 | PULLDOWN ;
NET "E_CRS"     LOC = "H12" | IOSTANDARD = LVCMOS33 | PULLDOWN ;
NET "E_MDC"     LOC = "D10" | IOSTANDARD = LVCMOS33 | SLEW = SLOW | DRIVE = 8;
NET "E_MDIO"    LOC = "E10" | IOSTANDARD = LVCMOS33 | SLEW = SLOW | DRIVE = 8;
NET "E_NRST"    LOC = "D15" | IOSTANDARD = LVCMOS33 | SLEW = SLOW | DRIVE = 8;
NET "E_RX_CLK"  LOC = "C12" | IOSTANDARD = LVCMOS33 ;
NET "E_RX_DV"   LOC = "H10" | IOSTANDARD = LVCMOS33 ;
NET "E_RXD<0>"  LOC = "G7"  | IOSTANDARD = LVCMOS33 | PULLUP ;
NET "E_RXD<1>"  LOC = "G8"  | IOSTANDARD = LVCMOS33 | PULLUP ;
NET "E_RXD<2>"  LOC = "G9"  | IOSTANDARD = LVCMOS33 | PULLUP ;
NET "E_RXD<3>"  LOC = "H9"  | IOSTANDARD = LVCMOS33 | PULLUP ;
NET "E_RXD<4>"  LOC = "G10" | IOSTANDARD = LVCMOS33 ;
NET "E_TX_CLK"  LOC = "E11" | IOSTANDARD = LVCMOS33 ;
NET "E_TX_EN"   LOC = "D8"  | IOSTANDARD = LVCMOS33 | SLEW = FAST | DRIVE = 8;
NET "E_TXD<0>"  LOC = "F8"  | IOSTANDARD = LVCMOS33 | SLEW = FAST | DRIVE = 8;
NET "E_TXD<1>"  LOC = "E7"  | IOSTANDARD = LVCMOS33 | SLEW = FAST | DRIVE = 8;
NET "E_TXD<2>"  LOC = "E6"  | IOSTANDARD = LVCMOS33 | SLEW = FAST | DRIVE = 8;
NET "E_TXD<3>"  LOC = "F7"  | IOSTANDARD = LVCMOS33 | SLEW = FAST | DRIVE = 8;
NET "E_TXD<4>"  LOC = "B2"  | IOSTANDARD = LVCMOS33 | SLEW = FAST | DRIVE = 8 | PULLUP
;

```

Figure 14-3: UCF Location Constraints for 10/100 Ethernet PHY Inputs

Related Resources

Refer to the following links for additional information:

- **Standard Microsystems SMSC LAN8700 10/100 Ethernet PHY**
<http://www.smSC.com/main/catalog/lan8700.html>
- **Xilinx OPB Ethernet Media Access Controller (EMAC) (v1.04a)**
www.xilinx.com/support/documentation/ip_documentation/opb_ethernet.pdf
- **Xilinx OPB Ethernet Lite Media Access Controller (v1.01a)**
 The Ethernet Lite MAC controller core uses fewer FPGA resources and is ideal for applications that do not require support for interrupts, back-to-back data transfers, and statistics counters.
www.xilinx.com/support/documentation/ip_documentation/opb_ethernetlite.pdf
- **EDK Documentation**
http://www.xilinx.com/ise/embedded/edk_docs.htm

Expansion Connectors

The Spartan[®]-3A/3AN FPGA Starter Kit board provides a variety of expansion connectors for easy interface flexibility to other off-board components. The board includes the I/O expansion headers shown in [Figure 15-1](#).

- A Hirose 100-pin edge connector with 43 associated FPGA user-I/O pins
- Two stake pin headers, each that supports up to five differential data channels plus a differential clock or 12 single-ended I/O signals.
- Two six-pin Peripheral Module connections, plus mounting holes for a third module.
- Landing pads for an Agilent or Tektronix connectorless probe

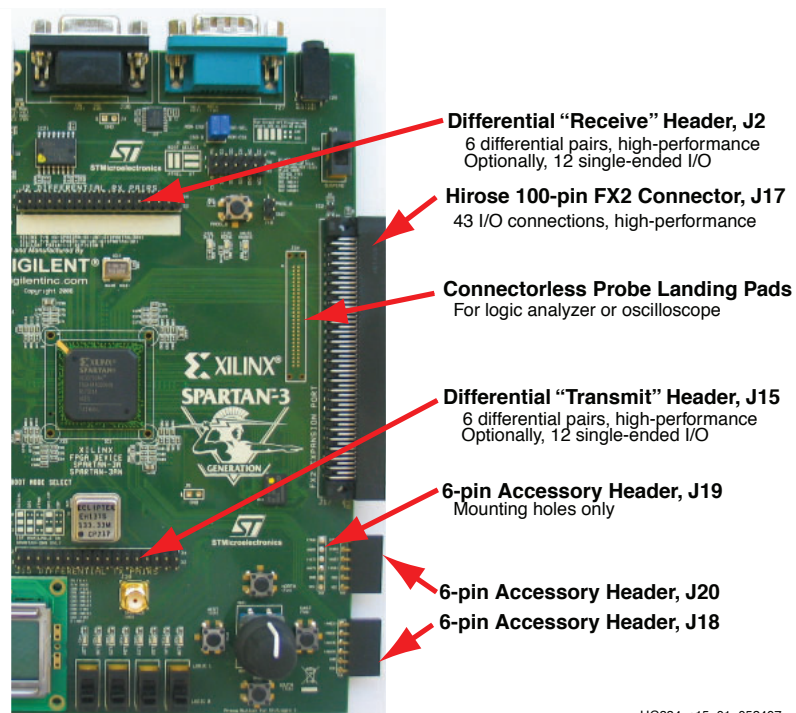
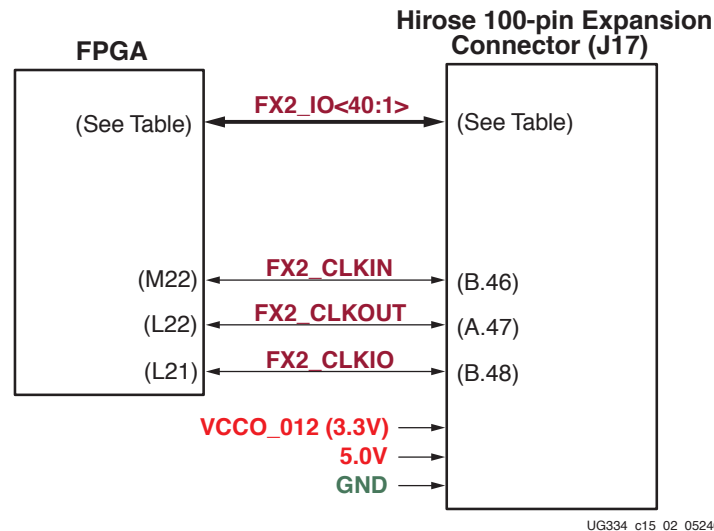

Figure 15-1: Expansion Headers

Hirose 100-Pin FX2 Edge Connector (J17)

A 100-pin edge connector is located along the right edge of the board. This connector is a Hirose FX2-100P-1.27DS header with 1.27 mm pitch. Throughout the documentation, this connector is called the FX2 connector.

As shown in [Figure 15-2](#), 43 FPGA I/O pins interface to the FX2 connector.



UG334_c15_02_052407

Figure 15-2: FPGA Connections to the Hirose 100-Pin Edge Connector

Three signals are reserved primarily as clock signals between the board and FX2 connector, although all three connect to full I/O pins.

Expansion Connector Compatibility

For the majority of applications, the FX2 connector on the Spartan-3A/3AN Starter Kit board is compatible with the other Xilinx development boards. The Spartan-3E Starter Kit board and XC3S1600E Starter Kit board optionally provide limited differential I/O capability on the FX2 connector. The Spartan-3A/3AN Starter Kit board provides enhanced differential I/O support using the “[Differential I/O Connectors](#),” page 124.

- **Spartan-3E Starter Kit board**
www.xilinx.com/s3estarter
- **XC3S1600E MicroBlaze Embedded Development Board**
www.xilinx.com/sp3e1600e

Furthermore, the Spartan-3A/3AN Starter Kit board supports the other “[FX2-Connector Compatible Boards](#),” page 122.

Voltage Supplies to the Connector

The Spartan-3A/3AN Starter Kit board provides power to the Hirose 100-pin FX connector and any attached board via two supplies (see [Figure 15-2](#)). The 5.0V supply provides a voltage source for any 5V logic on the attached board or alternately provides power to any voltage regulators on the attached board.

A separate supply provides the same voltage as that applied to the FPGA's I/O Banks 0, 1, and 2 called VCCO_012. This supply is 3.3V by default. All FPGA I/Os that interface to the Hirose connector are in Bank 0 or Bank 1.

For improved signal integrity, a majority of pins on the B side of the FX2 connector are tied to GND.

Connector Pinout and FPGA Connections

Table 15-1 shows the pinout for the Hirose 100-pin FX2 connector and the associated FPGA pin connections. The FX2 connect has two rows of connectors, both with 50 connections each, shown in the table using light yellow shading.

The pin assignment for the connector is identical to that used on the Spartan-3E Starter Kit board, although the Spartan-3E board pinout includes a few input-only pins. The Spartan-3A/3AN Starter Kit board pin assignment uses only full I/O pins and are backwards compatible with the Spartan-3E Starter Kit board.

Table 15-1: Hirose 100-Pin FX2 Connector Pinout and FPGA Connections (J17)

Signal Name	FPGA Pin	Shared	FX2 Connector		FPGA Pin	Signal Name
		J34	A (top)	B (bottom)		
Supply to FPGA I/O Banks 0, 1, 2	VCCO_012		1	1		SHIELD
	VCCO_012		2	2	GND	GND
TMS_B			3	3		TDO_XC2C
JTSEL			4	4		TCK_B
TDO_FX2			5	5	GND	GND
FX2_IO1	A13	◆	6	6	GND	GND
FX2_IO2	B13	◆	7	7	GND	GND
FX2_IO3	A14	◆	8	8	GND	GND
FX2_IO4	B15	◆	9	9	GND	GND
FX2_IO5	A15	◆	10	10	GND	GND
FX2_IO6	A16	◆	11	11	GND	GND
FX2_IO7	A17	◆	12	12	GND	GND
FX2_IO8	B17	◆	13	13	GND	GND
FX2_IO9	A18	◆	14	14	GND	GND
FX2_IO10	C18	◆	15	15	GND	GND
FX2_IO11	A19	◆	16	16	GND	GND
FX2_IO12	B19	◆	17	17	GND	GND
FX2_IO13	A20	◆	18	18	GND	GND
FX2_IO14	B20	◆	19	19	GND	GND
FX2_IO15	C19	◆	20	20	GND	GND
FX2_IO16	D19	◆	21	21	GND	GND
FX2_IO17	D18	◆	22	22	GND	GND
FX2_IO18	E17	◆	23	23	GND	GND
FX2_IO19	D20		24	24	GND	GND
FX2_IO20	D21		25	25	GND	GND
FX2_IO21	D22		26	26	GND	GND
FX2_IO22	E22		27	27	GND	GND

Table 15-1: Hirose 100-Pin FX2 Connector Pinout and FPGA Connections (J17)

Signal Name	FPGA Pin	Shared	FX2 Connector		FPGA Pin	Signal Name
		J34	A (top)	B (bottom)		
FX2_IO23	F18		28	28	GND	GND
FX2_IO24	F19		29	29	GND	GND
FX2_IO25	F20		30	30	GND	GND
FX2_IO26	E20		31	31	GND	GND
FX2_IO27	G20		32	32	GND	GND
FX2_IO28	G19		33	33	GND	GND
FX2_IO29	H19		34	34	GND	GND
FX2_IO30	J18		35	35	GND	GND
FX2_IO31	K18		36	36	GND	GND
FX2_IO32	K17		37	37	GND	GND
FX2_IO33	K19		38	38	GND	GND
FX2_IO34	K20		39	39	GND	GND
FX2_IO35	L19		40	40	GND	GND
FX2_IO36	L18		41	41	GND	GND
FX2_IO37	M20		42	42	GND	GND
FX2_IO38	M18		43	43	GND	GND
FX2_IO39	L20		44	44	GND	GND
FX2_IO40	P20		45	45	GND	GND
GND	GND		46	46	M22	FX2_CLKIN
FX2_CLKOUT	L22		47	47	GND	GND
GND	GND		48	48	L21	FX2_CLKIO
5.0V			49	49		5.0V
5.0V			50	50		SHIELD

FX2-Connector Compatible Boards

The following boards are compatible with the FX2 connector on the starter kit board.

- **Digilent FX2 Wirewrap Board (FX2WW) from Digilent, Inc.**
<http://www.digilentinc.com/Products/Detail.cfm?Prod=FX2WW>
- **Digilent FX2 Breadboard (FX2BB) from Digilent, Inc.**
<http://www.digilentinc.com/Products/Detail.cfm?Prod=FX2BB>
- **Video Decoder Board (VDEC1) from Digilent, Inc.**
<http://www.digilentinc.com/Products/Detail.cfm?Prod=VDEC1>

Mating Receptacle Connectors

The Spartan-3A/3AN Starter Kit board uses a Hirose FX2-100P-1.27DS header connector. The header mates with any compatible 100-pin receptacle connector, including board-mounted and non-locking cable connectors.

- **Hirose connectors**
<http://www.hirose-connectors.com/>
- **FX2 Series Connector Data Sheet**
http://www.hirose.co.jp/cataloge_hp/e57220088.pdf

UCF Location Constraints

Figure 15-3 provides the UCF constraints for the FX2 connector, including the I/O pin assignment and the I/O standard used, assuming that all connections use single-ended I/O standards.

```
# ===== FX2 Connector (FX2) =====
NET "FX2_CLKIN" LOC = "M22" | IOSTANDARD = LVCMOS33 ;
NET "FX2_CLKIO" LOC = "L21" | IOSTANDARD = LVCMOS33 | SLEW = FAST | DRIVE = 8 ;
NET "FX2_CLKOUT" LOC = "L22" | IOSTANDARD = LVCMOS33 | SLEW = FAST | DRIVE = 8 ;
NET "FX2_IO<1>" LOC = "A13" | IOSTANDARD = LVCMOS33 | SLEW = FAST | DRIVE = 8 ;
NET "FX2_IO<2>" LOC = "B13" | IOSTANDARD = LVCMOS33 | SLEW = FAST | DRIVE = 8 ;
NET "FX2_IO<3>" LOC = "A14" | IOSTANDARD = LVCMOS33 | SLEW = FAST | DRIVE = 8 ;
NET "FX2_IO<4>" LOC = "B15" | IOSTANDARD = LVCMOS33 | SLEW = FAST | DRIVE = 8 ;
NET "FX2_IO<5>" LOC = "A15" | IOSTANDARD = LVCMOS33 | SLEW = FAST | DRIVE = 8 ;
NET "FX2_IO<6>" LOC = "A16" | IOSTANDARD = LVCMOS33 | SLEW = FAST | DRIVE = 8 ;
NET "FX2_IO<7>" LOC = "A17" | IOSTANDARD = LVCMOS33 | SLEW = FAST | DRIVE = 8 ;
NET "FX2_IO<8>" LOC = "B17" | IOSTANDARD = LVCMOS33 | SLEW = FAST | DRIVE = 8 ;
NET "FX2_IO<9>" LOC = "A18" | IOSTANDARD = LVCMOS33 | SLEW = FAST | DRIVE = 8 ;
NET "FX2_IO<10>" LOC = "C18" | IOSTANDARD = LVCMOS33 | SLEW = FAST | DRIVE = 8 ;
NET "FX2_IO<11>" LOC = "A19" | IOSTANDARD = LVCMOS33 | SLEW = FAST | DRIVE = 8 ;
NET "FX2_IO<12>" LOC = "B19" | IOSTANDARD = LVCMOS33 | SLEW = FAST | DRIVE = 8 ;
NET "FX2_IO<13>" LOC = "A20" | IOSTANDARD = LVCMOS33 | SLEW = FAST | DRIVE = 8 ;
NET "FX2_IO<14>" LOC = "B20" | IOSTANDARD = LVCMOS33 | SLEW = FAST | DRIVE = 8 ;
NET "FX2_IO<15>" LOC = "C19" | IOSTANDARD = LVCMOS33 | SLEW = FAST | DRIVE = 8 ;
NET "FX2_IO<16>" LOC = "D19" | IOSTANDARD = LVCMOS33 | SLEW = FAST | DRIVE = 8 ;
NET "FX2_IO<17>" LOC = "D18" | IOSTANDARD = LVCMOS33 | SLEW = FAST | DRIVE = 8 ;
NET "FX2_IO<18>" LOC = "E17" | IOSTANDARD = LVCMOS33 | SLEW = FAST | DRIVE = 8 ;
NET "FX2_IO<19>" LOC = "D20" | IOSTANDARD = LVCMOS33 | SLEW = FAST | DRIVE = 8 ;
NET "FX2_IO<20>" LOC = "D21" | IOSTANDARD = LVCMOS33 | SLEW = FAST | DRIVE = 8 ;
NET "FX2_IO<21>" LOC = "D22" | IOSTANDARD = LVCMOS33 | SLEW = FAST | DRIVE = 8 ;
NET "FX2_IO<22>" LOC = "E22" | IOSTANDARD = LVCMOS33 | SLEW = FAST | DRIVE = 8 ;
NET "FX2_IO<23>" LOC = "F18" | IOSTANDARD = LVCMOS33 | SLEW = FAST | DRIVE = 8 ;
NET "FX2_IO<24>" LOC = "F19" | IOSTANDARD = LVCMOS33 | SLEW = FAST | DRIVE = 8 ;
NET "FX2_IO<25>" LOC = "F20" | IOSTANDARD = LVCMOS33 | SLEW = FAST | DRIVE = 8 ;
NET "FX2_IO<26>" LOC = "E20" | IOSTANDARD = LVCMOS33 | SLEW = FAST | DRIVE = 8 ;
NET "FX2_IO<27>" LOC = "G20" | IOSTANDARD = LVCMOS33 | SLEW = FAST | DRIVE = 8 ;
NET "FX2_IO<28>" LOC = "G19" | IOSTANDARD = LVCMOS33 | SLEW = FAST | DRIVE = 8 ;
NET "FX2_IO<29>" LOC = "H19" | IOSTANDARD = LVCMOS33 | SLEW = FAST | DRIVE = 8 ;
NET "FX2_IO<30>" LOC = "J18" | IOSTANDARD = LVCMOS33 | SLEW = FAST | DRIVE = 8 ;
NET "FX2_IO<31>" LOC = "K18" | IOSTANDARD = LVCMOS33 | SLEW = FAST | DRIVE = 8 ;
NET "FX2_IO<32>" LOC = "K17" | IOSTANDARD = LVCMOS33 | SLEW = FAST | DRIVE = 8 ;
NET "FX2_IO<33>" LOC = "K19" | IOSTANDARD = LVCMOS33 | SLEW = FAST | DRIVE = 8 ;
NET "FX2_IO<34>" LOC = "K20" | IOSTANDARD = LVCMOS33 | SLEW = FAST | DRIVE = 8 ;
NET "FX2_IO<35>" LOC = "L19" | IOSTANDARD = LVCMOS33 | SLEW = FAST | DRIVE = 8 ;
NET "FX2_IO<36>" LOC = "L18" | IOSTANDARD = LVCMOS33 | SLEW = FAST | DRIVE = 8 ;
NET "FX2_IO<37>" LOC = "M20" | IOSTANDARD = LVCMOS33 | SLEW = FAST | DRIVE = 8 ;
NET "FX2_IO<38>" LOC = "M18" | IOSTANDARD = LVCMOS33 | SLEW = FAST | DRIVE = 8 ;
NET "FX2_IO<39>" LOC = "L20" | IOSTANDARD = LVCMOS33 | SLEW = FAST | DRIVE = 8 ;
NET "FX2_IO<40>" LOC = "P20" | IOSTANDARD = LVCMOS33 | SLEW = FAST | DRIVE = 8 ;
```

Figure 15-3: UCF Location Constraints for 100-Pin Hirose FX2 Connector

Differential I/O Connectors

The Spartan-3A/3AN Starter Kit board includes stake pin headers with excellent signal integrity and matched impedance traces to demonstrate high-performance differential I/O. Each differential pair supports approximately 600 Mbps per second (Mbps) data rates. All I/O pairs support differential input termination (DIFF_TERM) as described in the Spartan-3A and Spartan-3AN data sheets.

The board is primarily designed to support loopback operations using a standard 34-pin socket-to-socket cable.

The two differential I/O headers, shown in [Figure 15-1, page 119](#), consist of a 2x17 array of stake pins arranged on 0.1-inch centers. The headers are not keyed. Ground pins are interspersed with the signal pins for improved signal integrity over any attached cable. Power is also supplied, via the nominally 3.3V rail, labeled VCCO_012. The power connectors are for potential daughter cards that plug into the connector.

The J15 connector is primarily designed to transmit output data while the J2 connector is primarily designed to receive input data. However, both headers are equally good at transmitting differential data. The “Receive” header does have special provisions for capturing the receive clock input.

The pin assignment for the J2 “Receive” connector appears in [Table 15-2](#) and in [Table 15-4](#). The FPGA ball assignment is listed in parentheses.

Table 15-2: “Receive” Header (J2)

2	4	6	8	10	12	14	16	18	20	22	24	26	28	30	32	34
GND	GND	RXN_0 (B4)	GND	RXN_1 (A5)	GND	RXN_2 (A6)	3.3V	3.3V	3.3V	RXN_3 (A8)	GND	RXN_4 (C10)	GND	RX_ CLK_N (A11)	GND	GND
GND	GND	RXP_0 (A4)	GND	RXP_1 (B6)	GND	RXP_2 (A7)	3.3V	3.3V	3.3V	RXP_3 (A9)	GND	RXP_4 (A10)	GND	RX_ CLK_P (A12)	GND	GND
1	3	5	7	9	11	13	15	17	19	21	23	25	27	29	31	33

The pin assignment for the J15 “Transmit” connector appears in [Table 15-3](#) and in [Table 15-4](#). The FPGA ball assignment is listed in parentheses.

Table 15-3: “Transmit” Header (J15)

2	4	6	8	10	12	14	16	18	20	22	24	26	28	30	32	34
GND	GND	TXN_0 (AA3)	GND	TXN_1 (AA4)	GND	TXN_2 (AB6)	3.3V	3.3V	3.3V	TXN_3 (AB7)	GND	TXN_4 (AB8)	GND	TX_ CLK_N (AB10)	GND	GND
GND	GND	TXP_0 (AB2)	GND	TXP_1 (AB3)	GND	TXP_2 (AA6)	3.3V	3.3V	3.3V	TXP_3 (Y7)	GND	TXP_4 (AA8)	GND	TX_ CLK_P (AA10)	GND	GND
1	3	5	7	9	11	13	15	17	19	21	23	25	27	29	31	33

Table 15-4 provides further detail on the pin assignment, including the differential pair association, the FPGA ball assignment, and the connecting header pin.

Table 15-4: Differential I/O Connections and Header Connections

Differential Pair	Signal Name	FPGA Ball	FPGA Pin Name	Signal Direction	Header.Pin
“Receive” Header, J2 (Top Header)					
RX_<0>	RXN_<0>	B4	IO_L31N_0	I/O	J2.6
	RXP_<0>	A4	IO_L31P_0	I/O	J2.5
RX_<1>	RXN_<1>	A5	IO_L28N_0	I/O	J2.10
	RXP_<1>	B6	IO_L28P_0	I/O	J2.9
RX_<2>	RXN_<2>	A6	IO_L26N_0	I/O	J2.14
	RXP_<2>	A7	IO_L26P_0	I/O	J2.13
RX_<3>	RXN_<3>	A8	IO_L22N_0	I/O	J2.22
	RXP_<3>	A9	IO_L22P_0	I/O	J2.21
RX_<4>	RXN_<4>	C10	IO_L21N_0	I/O	J2.26
	RXP_<4>	A10	IO_L21P_0	I/O	J2.25
RX_CLK	RX_CLK_N	A11	IO_L18N_0 GLK7	I/O	J2.30
	RX_CLK_P	A12	IO_L18P_0 GCLK8	I/O	J2.29
“Transmit” Header J15 (Bottom Header)					
TX_<0>	TXN_<0>	AA3	IO_L03N_2	I/O	J1..6
	TXP_<0>	AB2	IO_L03P_2	I/O	J1.5
TX_<1>	TXN_<1>	AA4	IO_L04N_2	I/O	J1.10
	TXP_<1>	AB3	IO_L04P_2	I/O	J1.9
TX_<2>	TXN_<2>	AB6	IO_L08N_2	I/O	J1.14
	TXP_<2>	AA6	IO_L08P_2	I/O	J1.13
TX_<3>	TXN_<3>	AB7	IO_L10N_2	I/O	J1.22
	TXP_<3>	Y7	IO_L10P_2	I/O	J1.21
TX_<4>	TXN_<4>	AB8	IO_L12N_2	I/O	J1.26
	TXP_<4>	AA8	IO_L12P_2	I/O	J1.25
TX_CLK	TX_CLK_N	AB10	IO_L15N_2	I/O	J1.30
	TX_CLK_P	AA10	IO_L15P_2	I/O	J1.29

Using Differential Inputs

LVDS and RSDS differential inputs require input termination. Two options are generally available. The first option is to use external termination resistors, as shown in Figure 15-4a. External input termination resistors are not provided on the differential I/O pins.

The second option, called on-chip differential termination, is highlighted on the Spartan-3A/3AN Starter Kit board (see Figure 15-4b). This feature uses the DIFF_TERM attribute available on differential I/O signals. Each differential I/O pin includes a circuit that

behaves like an internal termination resistor of approximately 100Ω . On-chip differential termination is only available on full I/O pairs, not on Input-only pairs.

Differential inputs are powered by the V_{CCAUX} supply, which is 3.3V by default. Differential inputs are available in any I/O bank.

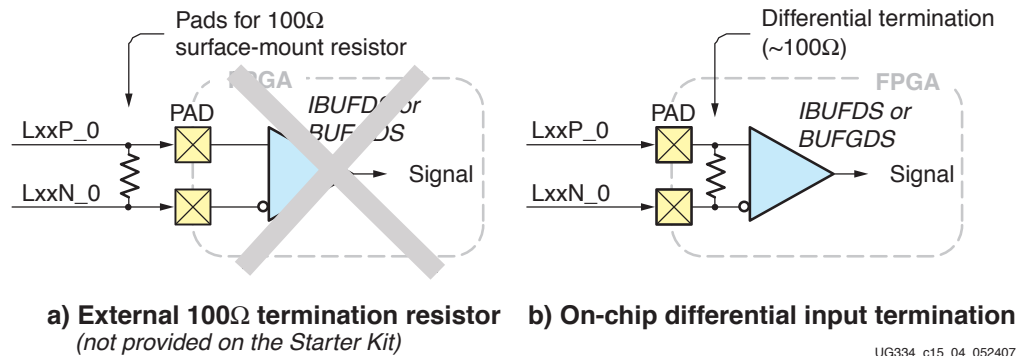

Figure 15-4: Differential Input Termination Options

Using Differential Outputs

Differential inputs are supported within any I/O bank. However, with Spartan-3A and Spartan-3AN FPGAs, differential outputs are only supported on I/O Bank 0 or 2. Differential outputs are powered by the respective I/O bank output voltage, V_{CCO} . On the Spartan-3A/3AN Starter Kit board, I/O Banks 0, 1, and 2 are all powered by a 3.3V supply.

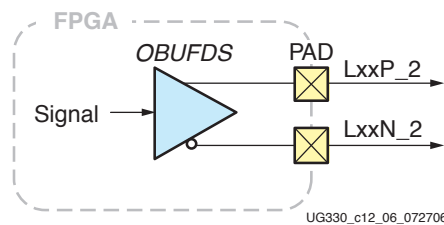

Figure 15-5: Differential Outputs

Differential Trace Layout Considerations

Figure 15-6 shows board layout extracted from the Starter Kit board that highlights the differential I/O signal traces. These traces were routed for optimal signal integrity.

- All differential pairs are routed with matched 100Ω impedance on the top board layer for maximum performance.
- The traces were routed to avoid via where possible.
- The trace lengths for differential pairs routed to a specific header (either the “Receive” or “Transmit” header) were matched to within 0.25 inches.
- The differential signals connections on the FPGA use the outer two ball rings to avoid breakout congestion.
- The “Receive” differential clock pair, highlighted in blue in Figure 15-6, connects to a differential global clock input pair, GCLK7 and GCLK8. Using these global clock

inputs, the differential input is converted to a single-ended clock signal within the FPGA. This clock input then feeds the upper-right DCM, labeled as DCM_X2Y3.

If using for differential inputs, set the DIFF_TERM=TRUE constraint. There are no external termination resistors provided on the board.

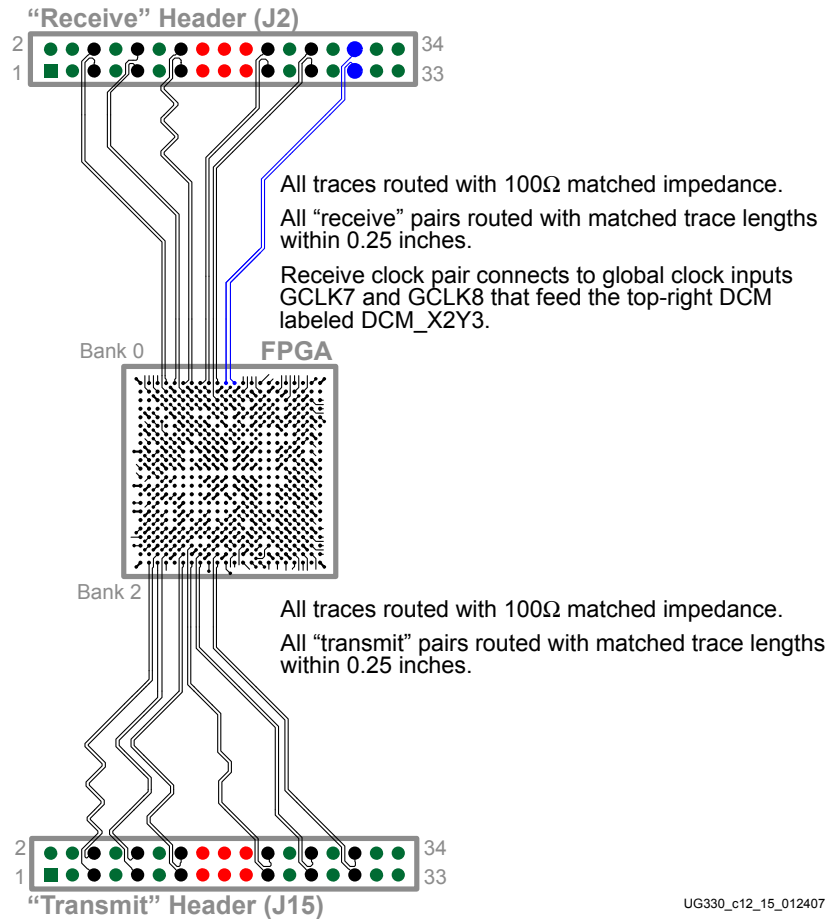

Figure 15-6: Differential I/O Layout

34-Conductor Cable Assemblies (2x17)

The J2 and J15 headers were designed specifically to connect to 34-conductor flat ribbon cable assemblies that use a 2x17, 0.1-inch form factor.

Table 15-5: Example 34-Conductor Cable Assemblies

Distributor	Manufacturer	Distributor Part Number	Type	Length
Digi-Key www.digikey.com	3M	M3AAK-3420K-ND	Flat ribbon cable, multi-color, twisted pair, gold finish	50.80 cm (20 inch)
	CW Industries	C3AAG-3406G-ND	Flat ribbon cable, gray, gold finish	15.24 cm (6 inch)
		C3AAG-3406M-ND	Flat ribbon cable, multi-color, gold finish	
	CW Industries	C3AAG-3418G-ND	Flat ribbon cable, gray, gold finish	45.72 cm (18 inch)
		C3AAG-3418M-ND	Flat ribbon cable, multi-color, gold finish	

UCF Location Constraints

Figure 15-7 provides the User Constraint File (UCF) constraints for the “Receive” and “Transmit” headers, including the I/O pin assignment and the I/O standard used.

```
# High-Speed LVDS "Receive" Connector (RX)
NET "RX_CLK_N" LOC = "A11" | IOSTANDARD = LVDS_33 ;
NET "RX_CLK_P" LOC = "A12" | IOSTANDARD = LVDS_33 ;
NET "RX_N<0>" LOC = "B4" | IOSTANDARD = LVDS_33 ;
NET "RX_P<0>" LOC = "A4" | IOSTANDARD = LVDS_33 ;
NET "RX_N<1>" LOC = "A5" | IOSTANDARD = LVDS_33 ;
NET "RX_P<1>" LOC = "B6" | IOSTANDARD = LVDS_33 ;
NET "RX_N<2>" LOC = "A6" | IOSTANDARD = LVDS_33 ;
NET "RX_P<2>" LOC = "A7" | IOSTANDARD = LVDS_33 ;
NET "RX_N<3>" LOC = "A8" | IOSTANDARD = LVDS_33 ;
NET "RX_P<3>" LOC = "A9" | IOSTANDARD = LVDS_33 ;
NET "RX_N<4>" LOC = "C10" | IOSTANDARD = LVDS_33 ;
NET "RX_P<4>" LOC = "A10" | IOSTANDARD = LVDS_33 ;

# High-Speed LVDS "Transmit" Connector (TX)
NET "TX_CLK_N" LOC = "AB10" | IOSTANDARD = LVDS_33 ;
NET "TX_CLK_P" LOC = "AA10" | IOSTANDARD = LVDS_33 ;
NET "TX_N<0>" LOC = "AA3" | IOSTANDARD = LVDS_33 ;
NET "TX_P<0>" LOC = "AB2" | IOSTANDARD = LVDS_33 ;
NET "TX_N<1>" LOC = "AA4" | IOSTANDARD = LVDS_33 ;
NET "TX_P<1>" LOC = "AB3" | IOSTANDARD = LVDS_33 ;
NET "TX_N<2>" LOC = "AB6" | IOSTANDARD = LVDS_33 ;
NET "TX_P<2>" LOC = "AA6" | IOSTANDARD = LVDS_33 ;
NET "TX_N<3>" LOC = "AB7" | IOSTANDARD = LVDS_33 ;
NET "TX_P<3>" LOC = "Y7" | IOSTANDARD = LVDS_33 ;
NET "TX_N<4>" LOC = "AB8" | IOSTANDARD = LVDS_33 ;
NET "TX_P<4>" LOC = "AA8" | IOSTANDARD = LVDS_33 ;
```

Figure 15-7: UCF Location Constraints for “Receive” and “Transmit” Headers

Six-Pin Accessory Headers

The six-pin accessory headers provide easy I/O interface expansion using the various Digilent Peripheral Modules.

J18 Header

The J18 header, shown in Figure 15-8, is located in the bottom right corner of the board, along the right edge, adjacent to the BTN_EAST push button. It uses a female six-pin 90° socket. Four FPGA pins connect to the J18 header, J18_IO<4:1>. The board supplies 3.3V to the accessory board mounted in the J18 socket on the bottom pin.

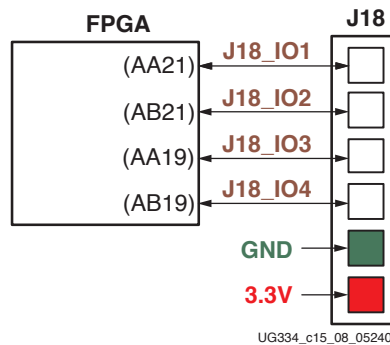

Figure 15-8: FPGA Connections to the J18 Accessory Header

J19 Header

The J19 header, shown in Figure 15-9, is left unpopulated on the board. Four FPGA pins connect to the J19 header, J19_IO<4:1>. The board supplies 3.3V to the accessory board mounted in the J19 socket on the bottom pin.

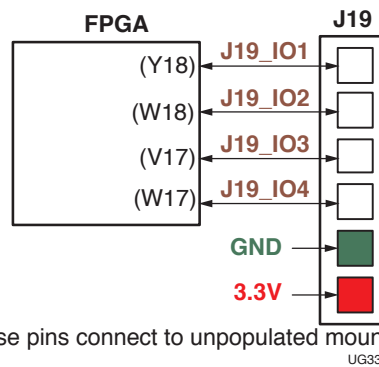

Figure 15-9: FPGA Connections to the J19 Accessory Header

J20 Header

The J20 header, shown in [Figure 15-10](#), is the top-most six-pin connector along the right edge of the board. It uses a female six-pin 90° socket. Four FPGA pins connect to the J20 header, J20_IO<4:1>. The board supplies 3.3V to the accessory board mounted in the J20 socket on the bottom pin.

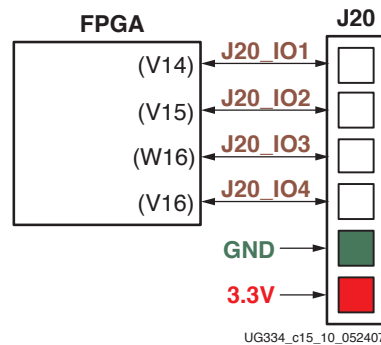

Figure 15-10: FPGA Connections to the J20 Accessory Header

Digilent Peripheral Modules

Digilent Peripheral Modules (PMods) are small I/O interface boards that offer an ideal way to extend the capabilities of programmable logic and embedded control boards. They allow sensitive signal conditioning circuits and high-power drive circuits to be placed where they are most effective - near sensors and actuators. PMods communicate with system boards using six-wire cables that can carry up to four digital control signals, including SPI and other serial protocols. PMods allow more effective design partitions by routing analog signals and power supplies only where they are needed and away from digital controller boards.

- **Digilent, Inc. Peripheral Modules**
<http://www.digilentinc.com/Products/Catalog.cfm?Cat=Peripheral>

UCF Location Constraints

Figure 15-11 provides the User Constraint File (UCF) constraints for the accessory headers, including the I/O pin assignment and the I/O standard used.

```
# ===== 6-pin header J18 =====
NET "J18_IO<1>" LOC = "AA21" | IOSTANDARD = LVCMOS33 | SLEW = SLOW | DRIVE = 8 ;
NET "J18_IO<2>" LOC = "AB21" | IOSTANDARD = LVCMOS33 | SLEW = SLOW | DRIVE = 8 ;
NET "J18_IO<3>" LOC = "AA19" | IOSTANDARD = LVCMOS33 | SLEW = SLOW | DRIVE = 8 ;
NET "J18_IO<4>" LOC = "AB19" | IOSTANDARD = LVCMOS33 | SLEW = SLOW | DRIVE = 8 ;

# ===== 6-pin header J19 =====
# These four connections go to through-hole pads, not to a connector.
NET "J19_IO<1>" LOC = "Y18" | IOSTANDARD = LVCMOS33 | SLEW = SLOW | DRIVE = 8 ;
NET "J19_IO<2>" LOC = "W18" | IOSTANDARD = LVCMOS33 | SLEW = SLOW | DRIVE = 8 ;
NET "J19_IO<3>" LOC = "V17" | IOSTANDARD = LVCMOS33 | SLEW = SLOW | DRIVE = 8 ;
NET "J19_IO<4>" LOC = "W17" | IOSTANDARD = LVCMOS33 | SLEW = SLOW | DRIVE = 8 ;

# ===== 6-pin header J20 =====
NET "J20_IO<1>" LOC = "V14" | IOSTANDARD = LVCMOS33 | SLEW = SLOW | DRIVE = 8 ;
NET "J20_IO<2>" LOC = "V15" | IOSTANDARD = LVCMOS33 | SLEW = SLOW | DRIVE = 8 ;
NET "J20_IO<3>" LOC = "W16" | IOSTANDARD = LVCMOS33 | SLEW = SLOW | DRIVE = 8 ;
NET "J20_IO<4>" LOC = "V16" | IOSTANDARD = LVCMOS33 | SLEW = SLOW | DRIVE = 8 ;
```

Figure 15-11: UCF Location Constraints for Six-Pin Accessory Headers

Connectorless Debugging Port Landing Pads (J34)

Landing pads for a connectorless debugging port are provided as the J34 header. There is no physical connector on the board. Instead a connectorless probe, such as those available from Agilent, provides an interface to a logic analyzer. This debugging port is intended primarily for the Xilinx ChipScope Pro software with the Agilent FPGA Dynamic Probe. It can, however, be used with either the Agilent or Tektronix probes, without the ChipScope software, using FPGA Editor's probe command.

- **Xilinx ChipScope Pro Tool**
www.xilinx.com/ise/optional_prod/cspro.htm
- **Agilent B4655A FPGA Dynamic Probe for Logic Analyzer**
www.home.agilent.com/agilent/redirector.jsp?action=ref&cname=PRODUCT&ckey=351182&lc=eng&cc=US
- **Agilent 5404A/6A Pro Series Soft Touch Connector**
<http://www.home.agilent.com/agilent/product.jsp?cc=US&lc=eng&pageMode=OV&pid=430362&ct=PRODUCT&id=430362>
- **Tektronix P69xx Probe Modules with D-Max Technology**
www.tek.com/products/accessories/logic_analyzers/p6800_p6900.html

Table 15-6 provides the connector pinout. Only 18 FPGA pins attach to the connector; the remaining connector pads are unconnected. All 18 FPGA pins are shared with the FX2 connector (J17). See Table 15-1, page 121 for more information on how these pins are shared.

Table 15-6: Connectorless Debugging Port Landing Pads (J34)

Signal Name	FPGA Pin	Connectorless Landing Pads		FPGA Pin	Signal Name
FX2_IO1	A13	A1	B1	GND	GND
FX2_IO2	B13	A2	B2	A14	FX2_IO3
GND	GND	A3	B3	B15	FX2_IO4
FX2_IO5	A15	A4	B4	GND	GND
FX2_IO6	A16	A5	B5	A17	FX2_IO7
GND	GND	A6	B6	B17	FX2_IO8
FX2_IO9	A18	A7	B7	GND	GND
FX2_IO10	C18	A8	B8	A19	FX2_IO11
GND	GND	A9	B9	B19	FX2_IO12
FX2_IO13	A20	A10	B10	GND	GND
FX2_IO14	B20	A11	B11	C19	FX2_IO15
GND	GND	A12	B12	D19	FX2_IO16
FX2_IO17	D18	A13	B13	GND	GND
FX2_IO18	E17	A14	B14		
		A15	B15		
		A16	B16		
		A17	B17		
		A18	B18		
		A19	B19		
		A20	B20		
		A21	B21		
		A22	B22		
		A23	B23		
		A24	B24		
		A25	B25		
		A26	B26		
		A27	B27		

Miniature Stereo Audio Jack

The Spartan®-3A/3AN FPGA Starter Kit board includes a miniature stereo audio jack plug, as highlighted in Figure 16-1. The jack plug is located in the upper right corner of the board, immediately above the SUSPEND slide switch.

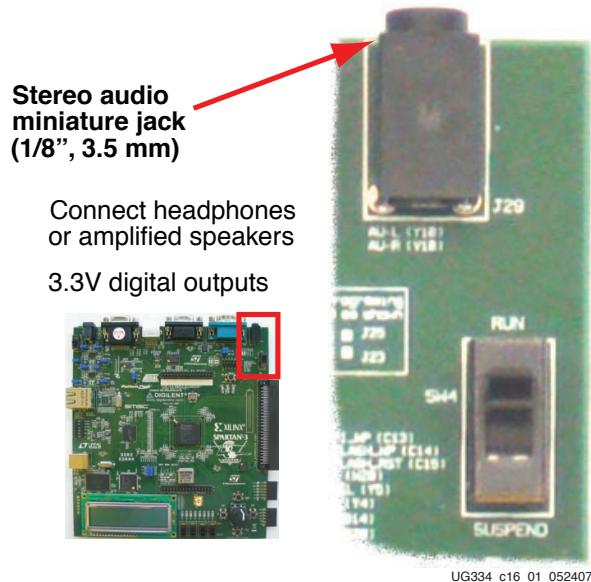

Figure 16-1: Stereo Miniature Jack

Supported Audio Devices

The port provides simple audio tones to an attached set of headphones or to amplified speakers. The audio device must use a 1/8th-inch or 3.5 mm audio jack, as shown in Figure 16-2. A stereo connector is highly recommended. The FPGA signal definition appears in Table 16-1.

A monophonic connector will function, but with the following limitations. Only drive signals on the AUD_L signal. Drive the AUD_R output to high-impedance (Hi-Z, three-state) so that it does not compete with the AUD_L channel.

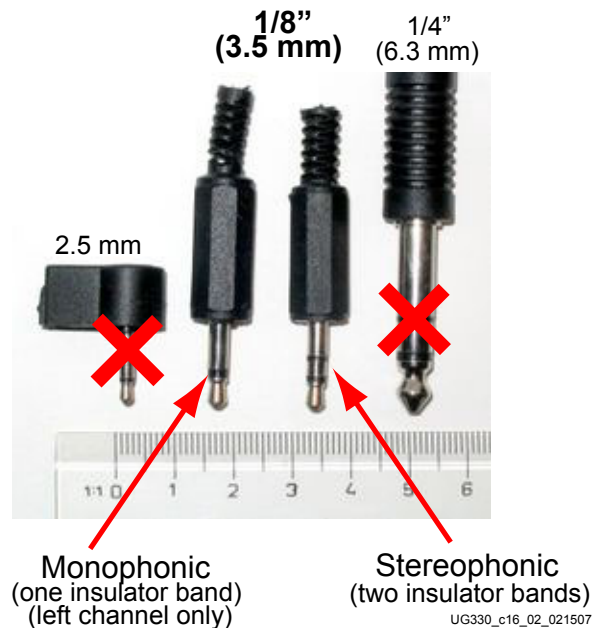

Figure 16-2: Examples of Miniature Stereo Jacks

FPGA Connections

The FPGA drives a 3.3V digital signal to each side of the audio jack, as indicated in Table 16-1. A monophonic connector only uses the left-side channel

Table 16-1: Digital Outputs to Stereo Minijack

Signal Name	FPGA Pins	Stereo Jack	Mono Jack
AUD_L	Y10	Left-side audio	Audio channel
AUD_R	V10	Right-side audio	Drive to Hi-Z

UCF Location Constraints

Figure 16-3 provides the UCF constraints for the audio connector.

```
# Controls VCCAUX supply rail (IC19)
NET "AUD_L" LOC = "Y10" | IOSTANDARD = LVCMOS33 | DRIVE = 8 | SLEW = SLOW ;
NET "AUD_R" LOC = "V10" | IOSTANDARD = LVCMOS33 | DRIVE = 8 | SLEW = SLOW ;
```

Figure 16-3: UCF Constraints for Audio Connector

Related Resources

The demonstration design shipped with the board includes an audio example.

- **Spartan-3A/3AN Starter Kit Demo Design Overview**
www.xilinx.com/products/boards/s3astarter/reference_designs.htm#demo
- **Restoring the “Out of the Box” Flash Programming**
www.xilinx.com/products/boards/s3astarter/reference_designs.htm#out

Voltage Supplies

The voltage supplies are located in the upper left corner of the board, as shown in Figure 17-1.

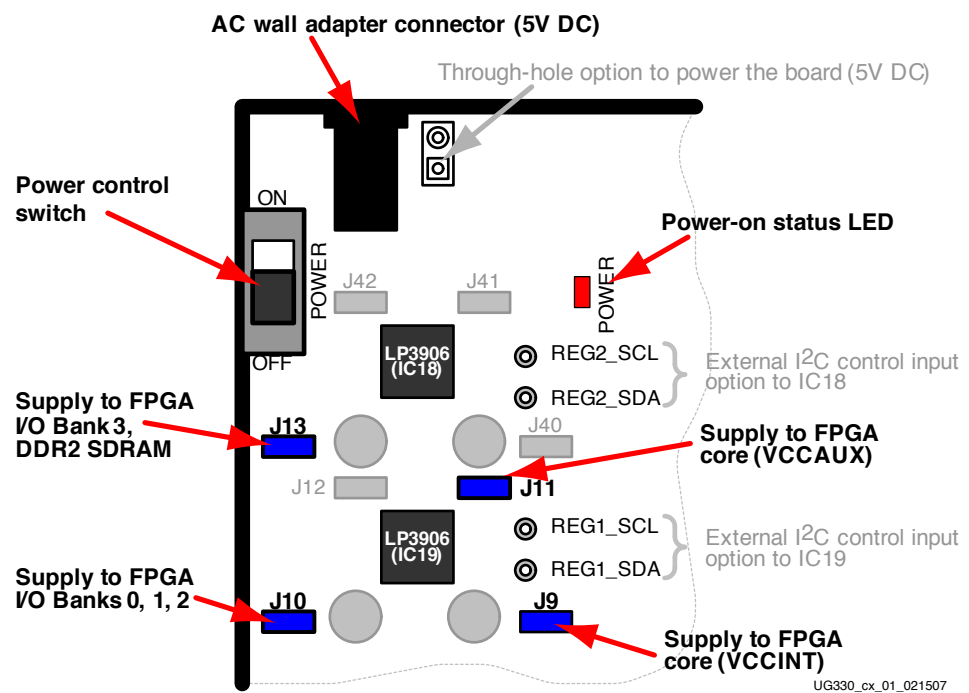

Figure 17-1: Spartan-3A/3AN Starter Kit Board Voltage Supplies

The Spartan®-3A/3AN FPGA Starter Kit board requires a 5.0V DC voltage input, typically supplied by the AC wall adapter included with the kit. However, there is also a provision to connect the board directly to a 5.0V DC supply using through-hole mounting solder pads.

The AC wall adapter must be a regulated 5.0V DC supply, as supplied with the kit. Some components and interfaces on the board, such as the LCD character display and the PS/2 port are powered directly from the 5.0V supply rail.

Caution! Connect either the AC wall adapter OR use the through-hole mounting pads, but not both.

The 5.0V input voltage is then converted to the other supply voltages required by the board components, as summarized in Table 17-1. All non-5V voltages are supplied by two space-efficient and cost-effective National Semiconductor LP3906 Quad-Output voltage

regulators. Each regulator incorporates two high-current switching (buck) regulators and two low-drop out (LDO) linear regulators.

Table 17-1: Voltage Regulators and Supply Rails

Voltage Regulator	Regulator Output	Voltage Level	Series Jumper Control	Components Supplied
National Semiconductor LP3906 (IC19)	SW1	1.2V	J9	FPGA internal core voltage, V_{CCINT}
	SW2	3.3V	J10	FPGA I/O Banks 0, 1, and 2 (V_{CCO_0} , V_{CCO_1} , and V_{CCO_2}). All 3.3V components.
	LDO1	3.3V	J11	FPGA internal auxiliary voltage, V_{CCAUX}
	LDO2	1.8V	J12	Embedded USB programmer
National Semiconductor LP3906 (IC18)	SW1	0.9V	J40	DDR2 SDRAM termination network
	SW2	1.8V	J13	DDR2 SDRAM component, FPGA I/O Bank 3 (V_{CCO_3})
	LDO1	3.3V	J41	Voltage reference to D/A converter channels C and D.
	LDO2	1.8V (voltage divided to 0.9V)	J42	DDR2 SDRAM voltage reference, FPGA I/O Bank 3 VREF inputs (V_{REF_3})

The board exploits all four regulator outputs for testing and evaluation purposes. However, a typical Spartan-3A/3AN FPGA application uses far fewer rails.

- The board uses a separate supply for V_{CCAUX} and sets it to 3.3V by default. In a typical application, the FPGA's V_{CCAUX} supply could connect directly to the 3.3V supply used for FPGA I/O Banks 0, 1, and 2.
 - ◆ By default, the V_{CCAUX} supply is set to 3.3V
 - ◆ Using the I²C interface on regulator IC19, V_{CCAUX} can be reduced to 2.5V to reduce overall power consumption or to verify operation with $V_{CCAUX} = 2.5V$.
- The DDR2 SDRAM interface uses multiple regulator outputs to test voltage margining.
 - ◆ One high-current 1.8V rail supports the DDR2 SDRAM component itself, and supplies the FPGA's I/O Bank 3, which connects to the DDR2 SDRAM.
 - ◆ One high-current 0.9V supplies the DDR2 SDRAM termination network.
 - ◆ A low-current 1.8V supply is voltage divided with resistors to provide a high-accuracy 0.9V voltage reference for the DDR2 SDRAM component and to supply the VREF inputs on FPGA I/O Bank 3.
 - ◆ See [Chapter 13, "DDR2 SDRAM"](#) for additional information.

Measuring Power Across Voltage Supply Jumpers

All regulator output supplies have an associated series jumper, as indicated in [Table 17-1](#) and shown in [Figure 17-1](#). This allows for simple and easy current monitoring using just a multimeter.

For example, to measure the Suspend mode current on the FPGA's V_{CCAUX} or V_{CCINT} supplies, follow these steps.

Caution! The Suspend feature must first be enabled in the actual FPGA application. All the example designs initially shipped with the board have the Suspend feature enabled.

- Disconnect power to the board.
- Remove the series jumper associated with the supply to be measured, shown in [Table 17-2](#). Locate jumper indicated in [Figure 17-1](#).

Table 17-2: FPGA Supply Rails and Associated Voltage Supply Jumper

FPGA Supply Rail	Associated Voltage Supply Jumper	Default Voltage
V_{CCINT}	J9	1.2V
V_{CCAUX}	J11	3.3V

- Connect a digital multimeter across the jumper, as highlighted in [Figure 17-2](#). If the resulting current is negative, simply reverse the connections to the jumpers.

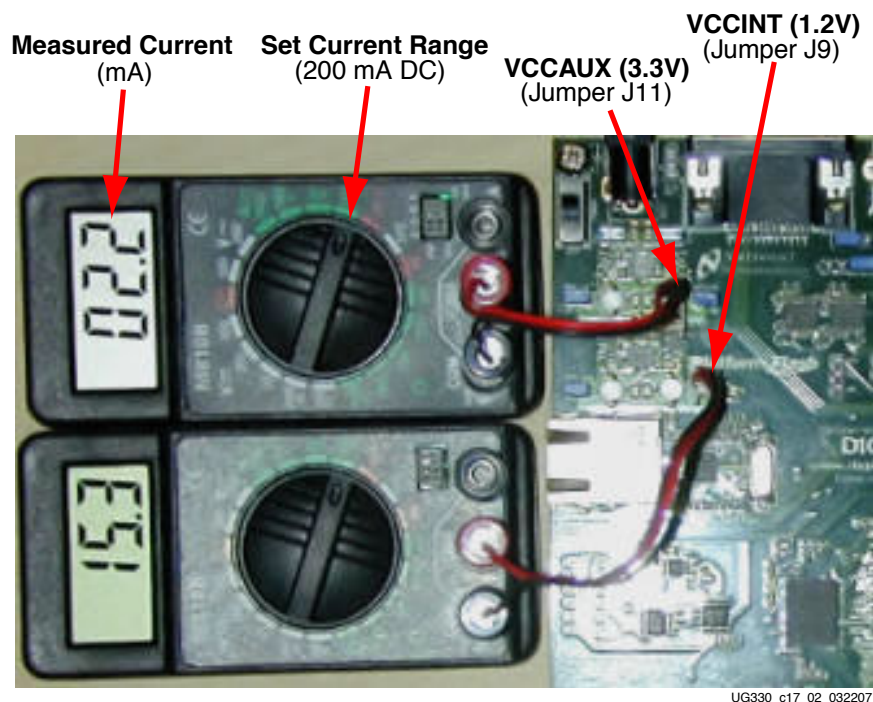

Figure 17-2: Measuring Current (Power) Using a Multimeter

- Set the meter to measure DC Amperes. Initially set the meter to the Ampere range. If appropriate, switch to a lower range (for example, 200 mA) after initially measuring current in the Ampere range.

Caution! If the meter offers various current ranges, always start with the largest range first. Passing too large a current through a meter may damage it.

- Reapply power to the board.
- Record the current measurements across the jumper.
- If the FPGA design supports the power-saving Suspend mode, measure the current with the SUSPEND switch (see “SUSPEND Switch,” page 26) set in both the “RUN” and “SUSPEND” positions. The default FPGA application shipped with the Starter Kit board does use the Suspend mode. For additional information on the Suspend mode, see the “Power Management Solutions” chapter in [UG331: Spartan-3 Generation FPGA User Guide](#).
- Convert the current measurement (Amperes or mA) to a power measurement (Watts or mW), by multiplying the measured result by the supply voltage.

I²C Voltage Adjustment Interface

Each LP3906 regulator has an two-wire, I²C serial interface that optionally controls various functions, such as the regulator output voltage. As indicated in [Table 17-3](#), the I²C interface can be controlled by the FPGA application using the I/O pins indicated or by some external controller using the through-hole mounting pads provided on the board, shown in [Figure 17-1](#).

Table 17-3: I²C Voltage Adjustment Interface to Regulator

Regulator	I ² C Control Input	FPGA Connection	Through-Hole Connection
IC18	SCL	REG2_SCL (D11)	REG2-SCL
	SDA	REG2_SDA (F13)	REG2-SDA
IC19	SCL	REG1_SCL (E13)	REG1-SCL
	SDA	REG1_SDA (D13)	REG1-SDA

Possible Applications

For experimentation purposes only, Xilinx only recommends adjusting the two supplies listed below:

- By default, the V_{CCAUX} supply to the FPGA is set to 3.3V, as required for Spartan-3AN FPGAs. On Spartan-3A FPGAs, V_{CCAUX} can be either 2.5V or 3.3V, with potentially lower power consumption at 2.5V. Consequently, V_{CCAUX} can be reduced to 2.5V by adjusting the LDO1 output on the LP3906 regulator designated IC19. The corresponding I²C control signals are REG1_SCL and REG1_SDA.
- By default, the reference voltage to Channels C and D on the D/A converter is 3.3V. However, this voltage can be adjusted to between 1.0V and 3.3V by controlling the LDO1 output on IC18. The corresponding I²C control signals are REG2_SCL and REG2_SDA. See [Chapter 10, “Digital-to-Analog Converter \(DAC\)”](#) for additional information.

Restoring Default Voltages

Any voltage adjustments are temporary and apply only as long as the 5.0V supply is connected. To restore the original regulator output voltages, remove and then reconnect the 5.0V supply input.

Caution! Simply toggling the power switch will not restore the original regulator output voltage! Remove and reconnect the external 5.0V supply input.

UCF Location Constraints

Figure 17-3 provides the UCF constraints for the I²C control signals to the regulators.

```
# Controls VCCAUX supply rail (IC19)
NET "REG1_SCL" LOC = "E13" | IOSTANDARD = LVCMOS33 | DRIVE = 8 | SLEW = SLOW ;
NET "REG1_SDA" LOC = "D13" | IOSTANDARD = LVCMOS33 | DRIVE = 8 | SLEW = SLOW ;

# Control D/A Converter reference voltage for Channels C and D (IC18)
NET "REG2_SCL" LOC = "D11" | IOSTANDARD = LVCMOS33 | DRIVE = 8 | SLEW = SLOW ;
NET "REG2_SDA" LOC = "F13" | IOSTANDARD = LVCMOS33 | DRIVE = 8 | SLEW = SLOW ;
```

Figure 17-3: UCF Constraints for Regulator I2C Control Signals

Related Resources

Refer to the following link for additional information:

- National Semiconductor LP3906 Dual High-Current Step-Down DC/DC and Dual Linear Regulator with I²C Compatible Interface
www.national.com/pf/LP/LP3906.html

