

2 MeV external proton beam line for PIGE/PIXE applications

May 2012

S. Braccini, A. Ereditato, I. Kreslo, M. Nirkko*, P. Scampoli, M. Weber, M. Zeller

An H⁻ ion beam is accelerated to 2 MeV by a RFQ Linac. The high energy beam transport (HEBT) section consists of two permanent magnet quadrupole (PMQ) doublets. Extraction to air is performed using 5 μm thin steel foil, yielding a 0-1.4 MeV proton beam. The extracted beam is used for proton induced gamma/X-ray emission (PIGE/PIXE), a reaction that can be used for material analysis due to the characteristic and well known gamma spectra of various targets.

* Corresponding author – e-mail: martti.nirkko@cern.ch

Beam line for H⁻ ions at 2 MeV

Design and construction

Magnetic quadrupole fields can be induced using permanent magnets arranged as Halbach cylinders. Here, NdFeB magnets (40x10x10 mm³) were used to achieve a simple and cost-effective design. 3D-simulations of the magnetic fields inside the PMQs were done using finite element simulation software. The simulations were confirmed by measuring the transverse magnetic fields at various locations at the longitudinal centre of a PMQ prototype.

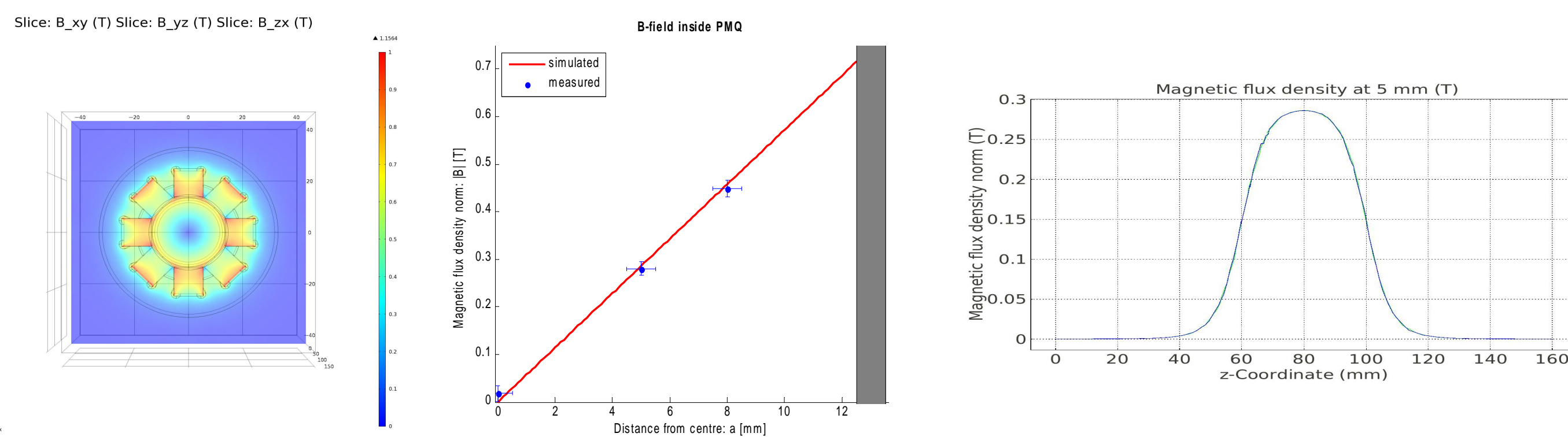

- Above left: cross section of the magnetic flux density norm at longitudinal centre of PMQ, linear colour scale from 0 (blue) to 1.0 T (red)
- Above centre: transverse B-field at centre of PMQ along r-axis, comparing simulated (red) to measured (blue) values
- Above right: simulation of longitudinal B-field in PMQ along z-axis at displacement $r = 5$ mm
- Left: schematic of PMQ with beam pipe

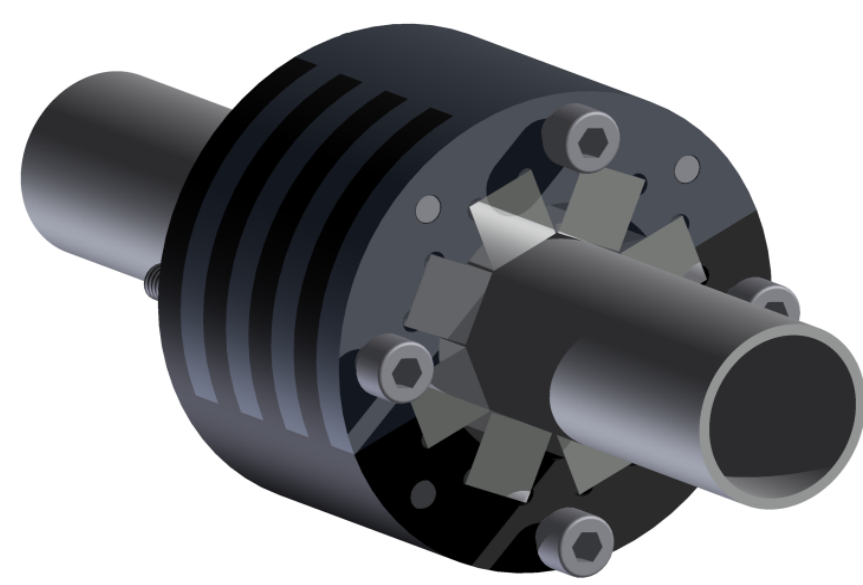

Simulations

A 2 MeV beam line for the RFQ Linac was realised using 4 identical PMQs by arranging them into two FODO doublets. Due to the equal focusing strength of each PMQ, the necessary degrees of freedom for manipulating the beam ellipses can be obtained by varying the longitudinal positions of the PMQs along the beam line. A Monte-Carlo simulation (MCS) was written to calculate particle trajectories for a given beam line (nominal emittance $0.6 \pi \cdot \text{mm} \cdot \text{mrad}$), and to determine the beam envelope. Similar results could be obtained by calculating the Twiss parameters using the beam ellipse approximation (BEA). Optimal positions for the PMQs were calculated using iterative (for MCS) and matching (for BEA) algorithms respectively.

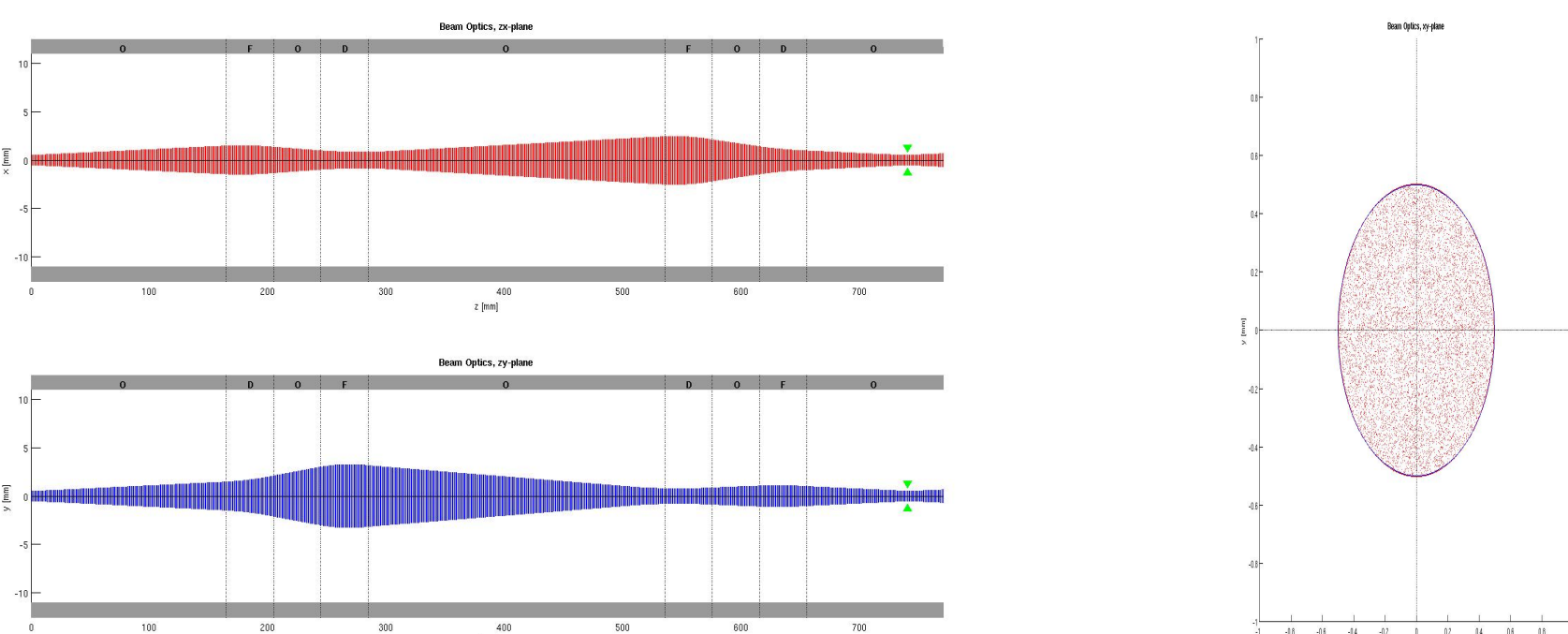

- Left: preliminary beam envelopes in zx-plane (red) and zy-plane (blue)
- Right: preliminary beam profile in xy-plane at target, assuming equally distributed particles

Results

The initial transverse beam emittance was estimated using a photo taken by projecting the beam through a steel mesh onto a glass scintillator. The results were used as new input for the simulations, the PMQ positions adjusted accordingly. The final beam size for the focused beam was observed on a borosilicate window, yielding a spot size of approx. $3 \times 2 \text{ mm}^2$ as expected. The average number of ions per second was $1 \cdot 10^{13} \text{ s}^{-1}$ with a peak current of 5 mA.



·Left: HEBT (length 55cm) consisting of four permanent magnet quadrupoles
·Right: focused beam made visible on glass scintillator (image size $2 \times 2 \text{ cm}^2$)

Beam extraction system for PIGE

Design and construction

An exit flange for the beam line was constructed using a modified blind flange. Thin foils of various materials and thicknesses can easily be inserted or replaced. Insertion of a supportive mesh is optional. Vacuum tightness is checked for using standard and helium leak tests.

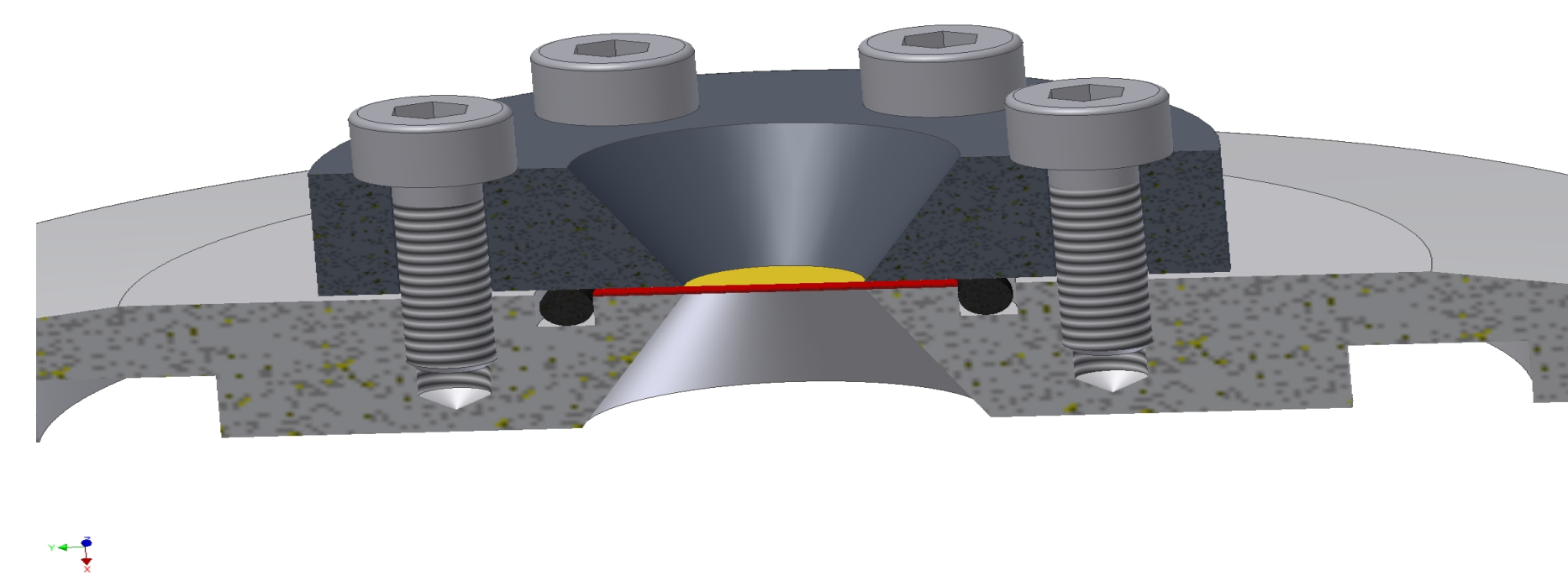

Cross-section schematic of exit flange ($\varnothing 4 \text{ cm}$): sealing O-ring (black), extraction foil (yellow) and optional mesh for support (red). Aperture size is 5 mm.

Simulations

Material stability of thin foils was estimated using stress-strain plots, to examine if the respective foil can withstand a pressure difference of 1 bar. Calculations for the transport of ions in matter were done using SRIM tables.

Results

Successful extraction of the 1.92 MeV (nominal value) H⁻ beam was performed using 5 μm (10 μm) stainless steel foil, thereby stripping the electrons. Estimated range of the extracted proton beam in air is 42 mm (26 mm), corresponding to an extraction energy of approx. 1.42 MeV (1.05 MeV).

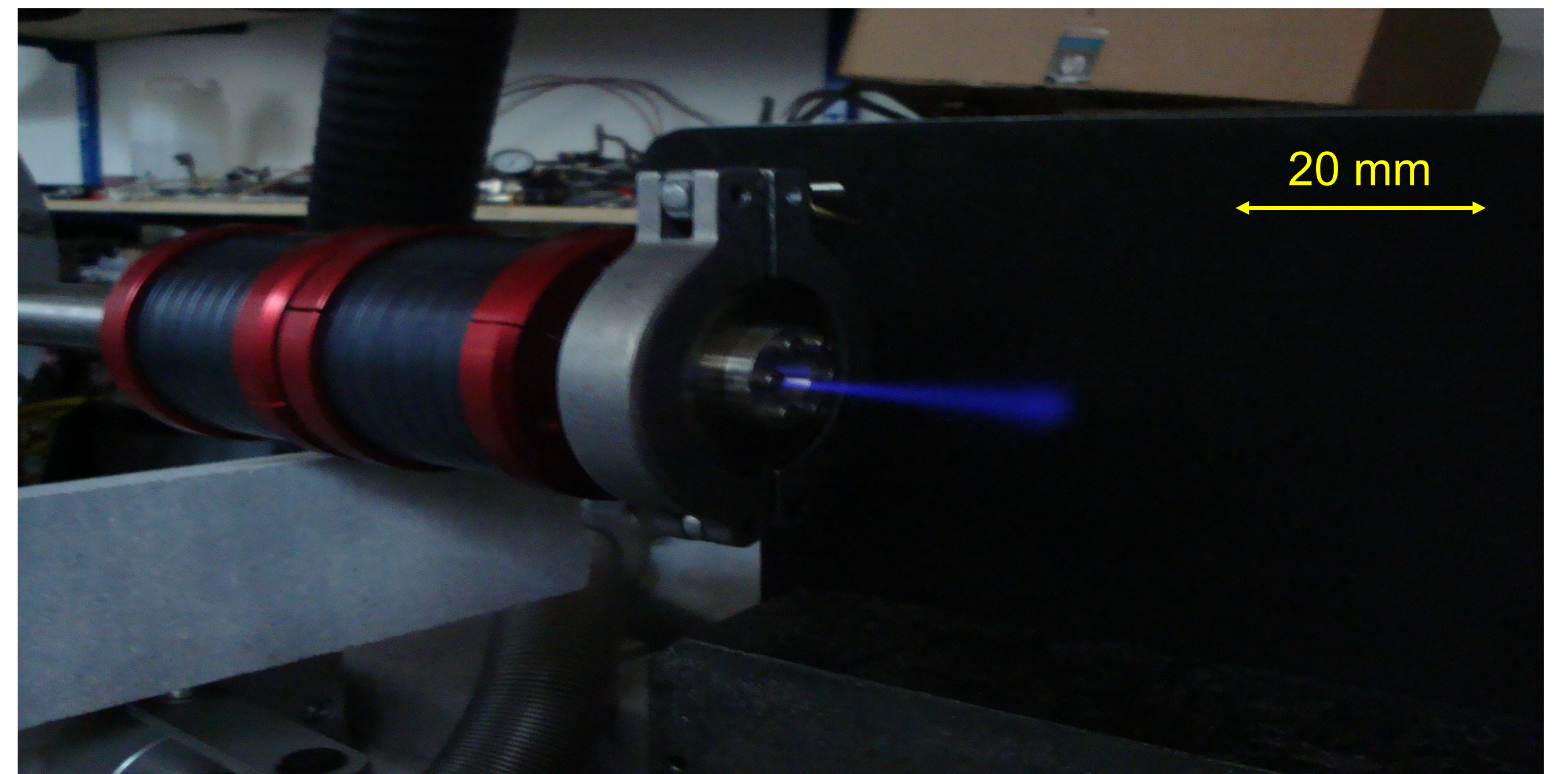

Beam extraction system: a vacuum-tight exit flange containing a 5 μm steel foil marks the end of the 2 MeV beam line. The H⁻ ions pass through the foil, thereby being stripped of electrons and losing approx. 0.5 MeV kinetic energy. The extracted proton beam is visible by eye (blue glow) through excitation of the air. The beam continues depositing energy and starts to grow, the widest and brightest part at the end indicates the Bragg peak.

Conclusions and outlook

A high energy beam transport section for a 2 MeV RFQ Linac consisting of two FODO cells was accomplished using four cost-effective permanent magnet quadrupoles. Successful extraction to air was performed at 1.4 MeV, enabling the elemental analysis of vacuum-sensitive targets via PIGE/PIXE reactions. Further possible applications include proton beam writing (PBW) and the use of the accelerator as a gamma-source for novel detectors.

Currently, gamma spectra are being taken for known PIGE reactions (such as $^{13}\text{C} + \text{p} \rightarrow ^{14}\text{N} + \gamma$ [9.17 MeV]) using a Germanium detector. In order to better characterise the beam parameters, an emittance-meter and a beam-profiler are being developed. The extraction system can be further improved by experimenting with thinner foils or less dense materials such as Kapton.